



COAXIAL

Bi-Directional Coupler ZFBDC20-62HP+

50Ω Up to 50W 10 to 600 MHz

FEATURES

- Excellent mainline loss, 0.25 dB typ.
- Excellent directivity, 25 dB typ.
- High power, up to 50W
- Rugged shielded case



Generic photo used for illustration purposes only

CASE STYLE: JD1252

Connectors	Model
BNC	ZFBDC20-62HP+
SMA	ZFBDC20-62HP-S+

APPLICATIONS

- Power leveling & monitoring
- Military mobile

+RoHS Compliant

The +Suffix identifies RoHS Compliance. See our website for methodologies and qualifications

ELECTRICAL SPECIFICATIONS

Parameter	Frequency (MHz)	Min.	Typ.	Max.	Units
Frequency Range		10		600	MHz
Mainline Loss ¹	10-600		0.25	0.70	dB
	10-450		0.20	0.50	
Coupling Nominal	10-600		20.0±0.5		dB
	10-450		20.2±0.5		
Coupling Flatness (±)	10-600		±0.9		dB
	10-450		±0.5		
Directivity	10-600	16	25		dB
	10-450	19	28		
VSWR	10-600		1.05		:1
	10-450		1.05		
Input Power ²	10-600			25	W
	10-450			50	

1. Mainline loss includes theoretical power loss at coupled port.

2. Power rating is specified up to +55°C. Power Input Specifications at +100°C is 50% value at +55°C. For specifications limits between +55°C and +100°C, derate linearly.

MAXIMUM RATINGS

Parameter	Ratings
Operating Temperature	-55°C to 100°C
Storage Temperature	-55°C to 100°C

Permanent damage may occur if any of these limits are exceeded.

ELECTRICAL SCHEMATIC

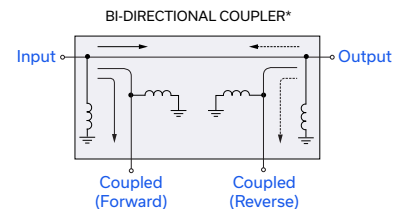

*Electrical schematic is for Bi-Directional coupler with internal transformer(s) that routes DC from all ports to ground





COAXIAL

Bi-Directional Coupler ZFBDC20-62HP+

Mini-Circuits

50Ω Up to 50W 10 to 600 MHz

COAXIAL CONNECTIONS

Input	1
Output	2
Coupled (Forward)	4
Coupled (Reverse)	3

OUTLINE DRAWING

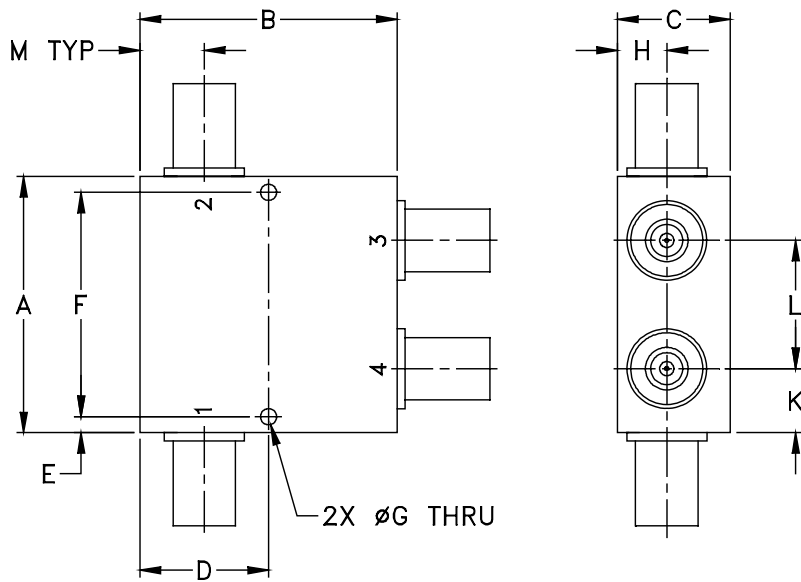

OUTLINE DIMENSIONS (Inch/mm)

A	B	C	D	E	F	G	
2.00	2.00	.88	1.000	0.13	1.750	0.125	
50.80	50.80	22.35	25.40	3.30	44.45	3.18	
H	J	K	L	M		wt	
0.38	--	0.50	1.00	0.50		grams	
9.65	--	12.70	25.40	12.70		250.0	



COAXIAL

Bi-Directional Coupler ZFBDC20-62HP+

50Ω Up to 50W 10 to 600 MHz

TYPICAL PERFORMANCE DATA AND CHARTS

Frequency (MHz)	Mainline Loss (dB) In-Out	Coupling (dB)		Directivity (dB)		Return Loss (dB)			
		In-Cpl Fwd	Out-Cpl Rev	Out-Cpl Fwd	In-Cpl Rev	In	Out	Cpl Fwd	Cpl Rev
10.00	0.08	20.22	20.16	28.32	28.02	24.73	24.90	24.55	24.68
100.00	0.17	20.34	20.24	38.07	39.56	40.49	41.50	39.26	38.86
200.00	0.19	20.30	20.29	30.76	31.59	51.68	47.45	42.77	39.00
250.00	0.20	20.26	20.29	28.54	29.31	57.26	51.33	42.90	38.78
300.00	0.22	20.20	20.30	27.39	27.67	50.07	48.46	42.80	39.03
400.00	0.25	20.03	20.26	25.18	25.48	43.61	47.73	41.30	38.25
450.00	0.27	19.93	20.22	24.33	24.69	41.20	45.96	39.53	37.21
500.00	0.30	19.80	20.15	23.67	24.17	38.61	43.31	37.27	35.43
550.00	0.32	19.66	20.07	23.13	23.71	35.69	40.97	35.19	34.11
600.00	0.35	19.49	19.95	22.75	23.44	33.51	37.54	33.31	32.45

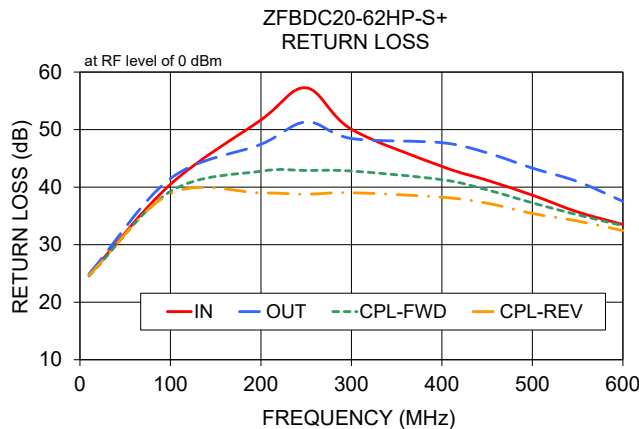
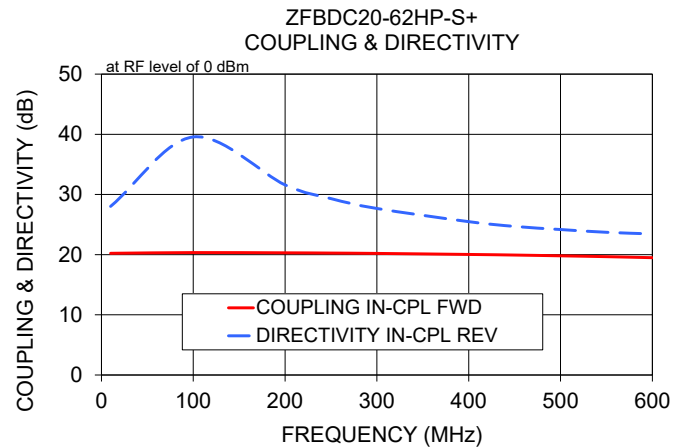
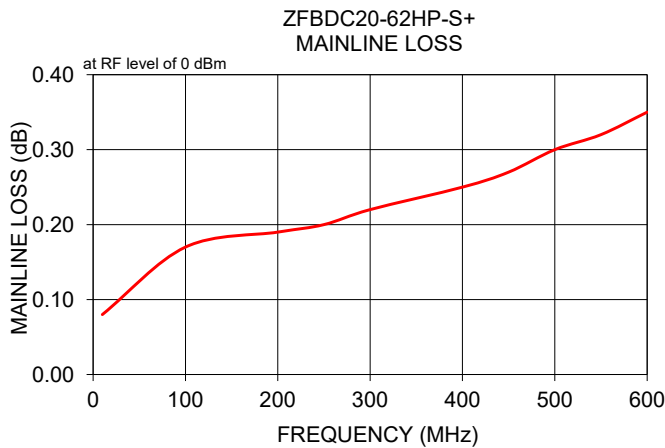

- NOTES**
- A. Performance and quality attributes and conditions not expressly stated in this specification document are intended to be excluded and do not form a part of this specification document.
 - B. Electrical specifications and performance data contained in this specification document are based on Mini-Circuit's applicable established test performance criteria and measurement instructions.
 - C. The parts covered by this specification document are subject to Mini-Circuits standard limited warranty and terms and conditions (collectively, "Standard Terms"); Purchasers of this part are entitled to the rights and benefits contained therein. For a full statement of the standard terms and the exclusive rights and remedies thereunder, please visit Mini-Circuits' website at www.minicircuits.com/terms/viewterm.html



Bi-Directional Coupler

ZFBDC20-62HP+

Typical Performance Data

FREQ. (MHz)	INSERTION LOSS (dB)		COUPLING (dB)		DIRECTIVITY (dB)		RETURN LOSS (dB)			
	IN-OUT	FWD-REV	IN-FWD	OUT-REV	IN-REV	OUT-FWD	IN	OUT	FWD	REV
10.0	0.08	0.10	20.22	20.16	28.02	28.32	24.73	24.90	24.55	24.68
30.0	0.13	0.15	20.25	20.16	44.92	46.01	35.00	36.22	34.88	35.25
100.0	0.17	0.19	20.34	20.24	39.56	38.07	40.49	41.50	39.26	38.86
150.0	0.18	0.19	20.33	20.27	33.15	33.59	42.61	44.11	40.31	39.41
200.0	0.19	0.20	20.30	20.29	31.59	30.76	51.68	47.45	42.77	39.00
250.0	0.20	0.21	20.26	20.29	29.31	28.54	57.26	51.33	42.90	38.78
300.0	0.22	0.23	20.20	20.30	27.67	27.39	50.07	48.46	42.80	39.03
350.0	0.23	0.24	20.12	20.28	26.45	26.23	45.60	48.39	42.16	38.85
400.0	0.25	0.25	20.03	20.26	25.48	25.18	43.61	47.73	41.30	38.25
425.0	0.26	0.26	19.98	20.24	25.07	24.71	42.55	47.00	40.64	37.78
450.0	0.27	0.27	19.93	20.22	24.69	24.33	41.20	45.96	39.53	37.21
475.0	0.28	0.28	19.86	20.19	24.41	23.99	39.92	44.43	38.28	36.33
500.0	0.30	0.29	19.80	20.15	24.17	23.67	38.61	43.31	37.27	35.43
550.0	0.32	0.31	19.66	20.07	23.71	23.13	35.69	40.97	35.19	34.11
600.0	0.35	0.34	19.49	19.95	23.44	22.75	33.51	37.54	33.31	32.45

Bi-Directional Coupler

ZFBDC20-62HP+

Typical Performance Curves

Insertion Loss

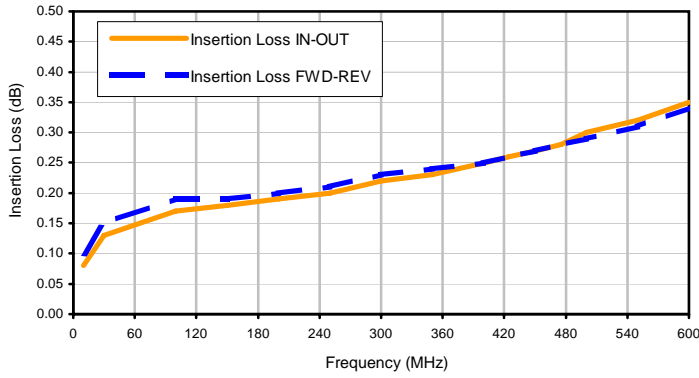

Coupling

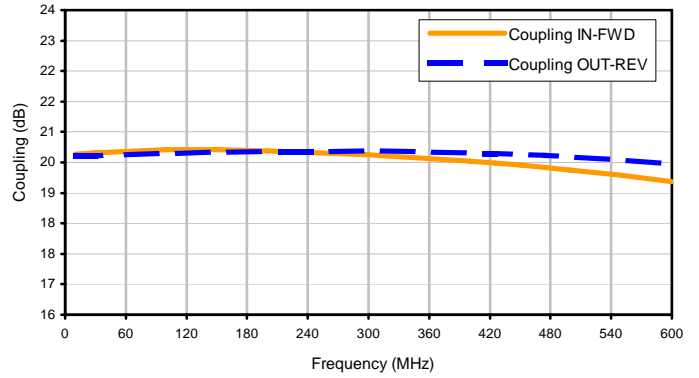

Directivity

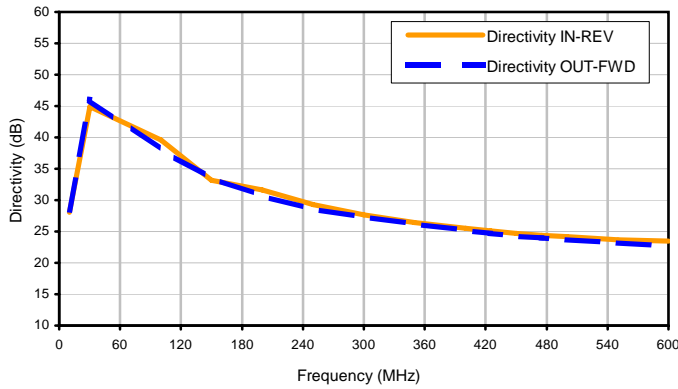

Return Loss

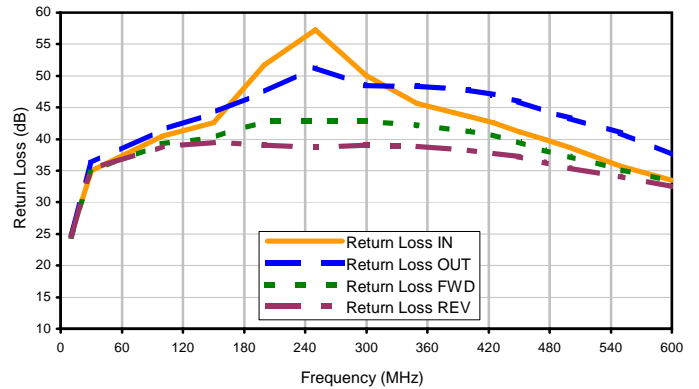

Outline Dimensions

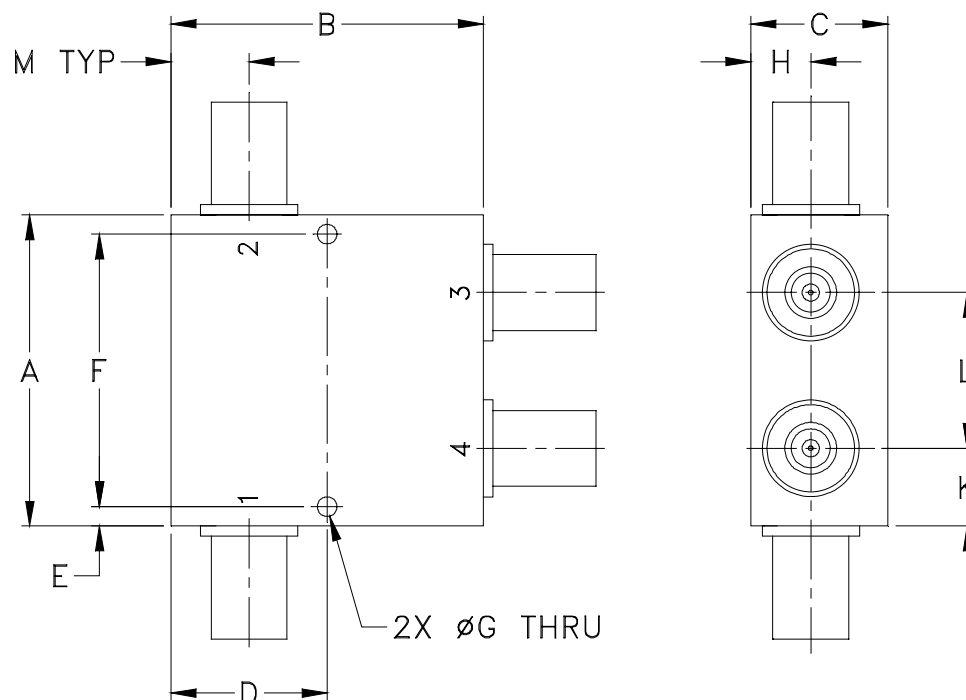

CASE#	A	B	C	D	E	F	G	H	J	K	L	M	WT, GRAM
JD1252	2.00 (50.80)	2.00 (50.80)	0.88 (22.35)	1.000 (25.40)	0.13 (3.18)	1.750 (44.45)	0.125 (3.18)	0.38 (9.65)	-- --	0.50 (12.70)	1.00 (25.40)	0.50 (12.70)	250.00

Dimensions are in inches (mm). Tolerances: 2 Pl. $\pm .03$; 3 Pl. $\pm .015$

Notes:

- Case material: Aluminum alloy.
- Case finish:
For RoHS Case Styles: Clear chemical conversion coating, non-chrome or trivalent chrome based.



INTERNET <http://www.minicircuits.com>

P.O. Box 350166, Brooklyn, New York 11235-0003 (718) 934-4500 Fax (718) 332-4661

Distribution Centers NORTH AMERICA 800-654-7949 • 417-335-5935 • Fax 417-335-5945 • EUROPE 44-1252-832600 • Fax 44-1252-837010

Mini-Circuits ISO 9001 & ISO 14001 Certified



All Mini-Circuits products are manufactured under exacting quality assurance and control standards, and are capable of meeting published specifications after being subjected to any or all of the following physical and environmental test.

Specification	Test/Inspection Condition	Reference/Spec
Operating Temperature	-55° to 100°C Ambient Environment	Individual Model Data Sheet
Storage Temperature	-55° to 100° C Ambient Environment	Individual Model Data Sheet
Barometric Pressure	100,000 Feet	MIL-STD-202, Method 105, Condition D
Humidity	90% RH, 65°C Units may require bake-out after humidity to restore full performance.	MIL-STD-202, Method 103
Thermal Shock	-65° to 125°C, 5 cycles	MIL-STD-202, Method 107, Condition B
Vibration (High Frequency)	20g peak, 10-2000 Hz, 12 times in each of three perpendicular directions (total 36)	MIL-STD-202, Method 204, Condition D
Mechanical Shock	100g, 6ms sawtooth, 3 shocks each direction 3 axes (total 18)	MIL-STD-202, Method 213, Condition I