

# Coaxial Diplexer

## ZDPLX-592-S+

50Ω 2.4 to 5.9 GHz  
(2.4 - 2.5, 5.1- 5.9 GHz)



Generic photo used for illustration purposes only

CASE STYLE: K18

### The Big Deal

- Very Low insertion loss, 0.8 dB typical
- High co-channel Rejection, 40 dB typical
- Connectorized package

### Product Overview

ZDPLX-592-S+ is a high performance hybrid diplexer with the lowpass port at 2.4 - 2.5 GHz and highpass port at 5.1 - 5.9 GHz. Built in a rugged connectorized package, this diplexer finds its application in Wi-Fi communication systems with high speed data rates.

### Key Features

Feature	Advantages
Low passband insertion loss	Very low insertion loss ensures less signal loss through the device.
Excellent co-channel rejection	Co-channel rejection of 40 dB ensures unwanted spurious are eliminated
Connectorized package	Connectorized package is easy to interface with other devices and well suited for test setups.

#### Notes

- A. Performance and quality attributes and conditions not expressly stated in this specification document are intended to be excluded and do not form a part of this specification document.  
B. Electrical specifications and performance data contained in this specification document are based on Mini-Circuit's applicable established test performance criteria and measurement instructions.  
C. The parts covered by this specification document are subject to Mini-Circuits standard limited warranty and terms and conditions (collectively, "Standard Terms"); Purchasers of this part are entitled to the rights and benefits contained therein. For a full statement of the Standard Terms and the exclusive rights and remedies thereunder, please visit Mini-Circuits' website at [www.minicircuits.com/MCLStore/terms.jsp](http://www.minicircuits.com/MCLStore/terms.jsp)



# Coaxial Diplexer

## ZDPLX-592-S+

50Ω 2.4 to 5.9 GHz (2.4-2.5, 5.1-5.9 GHz)

### Maximum Ratings

Operating Temperature	-40°C to 85°C
Storage Temperature	-55°C to 100°C
RF Power Input	1 W

Permanent damage may occur if any of these limits are exceeded.

### Coaxial Connections

HIGH PASS PORT	2
LOW PASS PORT	3
COMMON PORT	1

### Outline Drawing

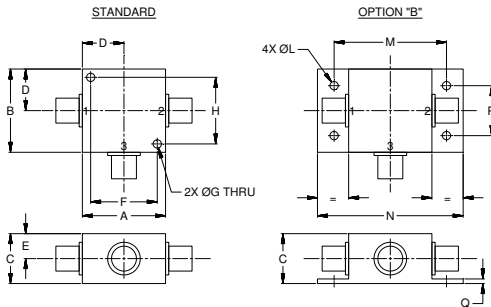

### Outline Dimensions (inch mm)

A	B	C	D	E	F	G	H
1.25	1.25	.75	.63	.38	1.000	.125	1.000
31.75	31.75	19.05	16.00	9.65	25.40	3.18	25.40
J	K	L	M	N	P	Q	Wt.
--	--	.125	1.688	2.18	.75	.07	grams
--	--	3.18	42.88	55.37	19.05	1.78	70.0

Note: Please refer to case style drawing for details

### Features

- Low insertion loss
- Very good co-channel rejection
- Connectorized package

### Applications

- Wi-Fi communication systems
- Mobile satellite
- Private & public land mobile



Generic photo used for illustration purposes only

CASE STYLE: K18

Connectors Model  
SMA ZDPLX-592-S+  
BRACKET (OPTION "B")

### +RoHS Compliant

The +Suffix identifies RoHS Compliance. See our web site for RoHS Compliance methodologies and qualifications

### Electrical Specifications at 25°C

Parameter	Port	Frequency (GHz)	Min.	Typ.	Max.	Unit
Pass Band	Insertion Loss	Low Pass	2.4-2.5	-	0.8	1.2
		High Pass	5.1-5.9	-	0.9	1.7
	Return Loss	Low Pass	2.4-2.5	10	16	-
		High Pass	5.1-5.9	8	12	-
Common		2.4-2.5	10	16	-	
Stop Band Isolation	Low Pass	5.1-5.9	38	45	-	
	High Pass	2.4-2.5	35	40	-	

### Typical Performance Data at 25°C

FREQUENCY (GHz)	INSERTION LOSS (dB)			RETURN LOSS (dB)	
	Low Pass Port	High Pass Port	Common Port	Low Pass Port	High Pass Port
0.01	0.02	102.05	47.95	45.76	0.00
0.10	0.07	85.34	30.41	30.62	0.05
0.70	0.26	62.39	18.14	18.21	0.18
1.50	0.33	51.65	24.76	22.92	0.19
2.00	0.53	47.66	16.04	15.78	0.21
2.40	0.65	42.87	17.43	17.53	0.24
2.50	0.67	41.53	22.19	23.52	0.24
2.70	1.11	37.66	14.34	15.54	0.27
2.84	3.79	32.31	4.78	6.23	0.30
2.88	6.31	30.45	2.79	4.05	0.30
2.98	18.99	27.35	0.91	1.53	0.33
3.00	23.06	26.91	0.83	1.36	0.33
3.08	30.72	25.43	0.69	0.96	0.35
3.20	24.69	23.38	0.65	0.69	0.39
3.30	25.39	21.72	0.64	0.58	0.42
3.40	27.25	20.07	0.69	0.51	0.45
3.54	30.96	17.82	0.82	0.45	0.53
4.00	46.38	10.20	3.02	0.38	1.18
4.30	43.45	5.32	3.64	0.35	2.62
4.50	41.58	3.11	5.43	0.34	4.59
5.10	45.63	0.77	19.79	0.31	18.86
5.90	48.45	0.71	18.00	0.25	17.36

### Functional Schematic

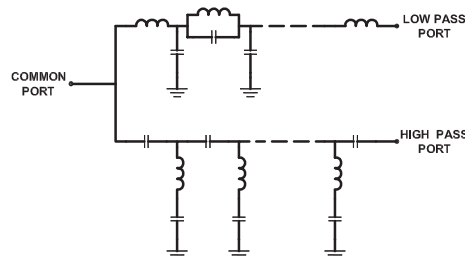

### Notes

- Performance and quality attributes and conditions not expressly stated in this specification document are intended to be excluded and do not form a part of this specification document.
- Electrical specifications and performance data contained in this specification document are based on Mini-Circuit's applicable established test performance criteria and measurement instructions.
- The parts covered by this specification document are subject to Mini-Circuit's standard limited warranty and terms and conditions (collectively, "Standard Terms"); Purchasers of this part are entitled to the rights and benefits contained therein. For a full statement of the Standard Terms and the exclusive rights and remedies thereunder, please visit Mini-Circuit's website at [www.minicircuits.com/MCLStore/terms.jsp](http://www.minicircuits.com/MCLStore/terms.jsp)



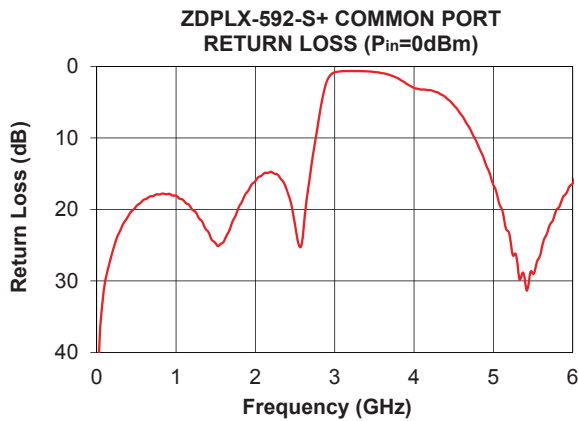
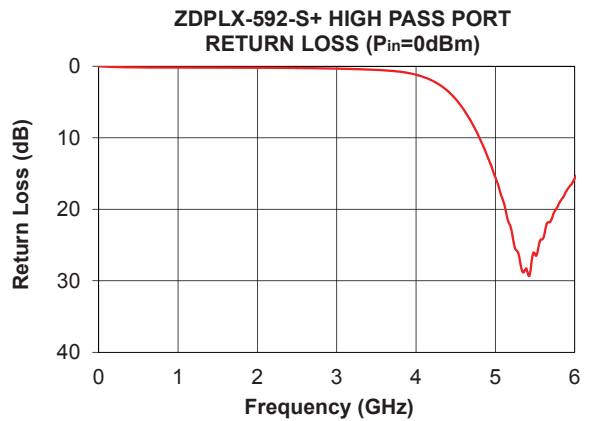
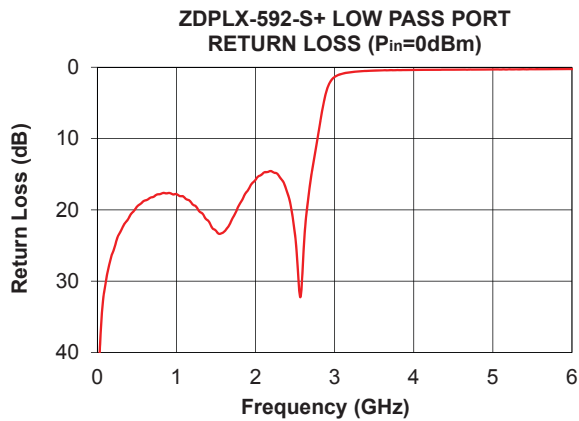
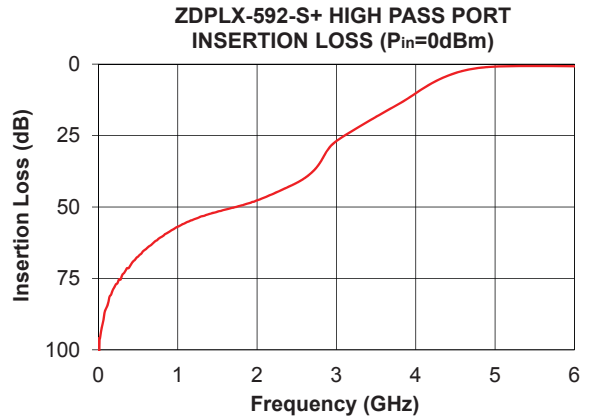
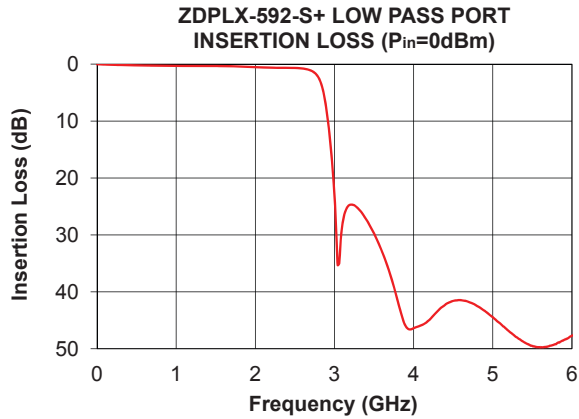

Notes

- A. Performance and quality attributes and conditions not expressly stated in this specification document are intended to be excluded and do not form a part of this specification document.
- B. Electrical specifications and performance data contained in this specification document are based on Mini-Circuit's applicable established test performance criteria and measurement instructions.
- C. The parts covered by this specification document are subject to Mini-Circuits standard limited warranty and terms and conditions (collectively, "Standard Terms"); Purchasers of this part are entitled to the rights and benefits contained therein. For a full statement of the Standard Terms and the exclusive rights and remedies thereunder, please visit Mini-Circuits' website at [www.minicircuits.com/MCLStore/terms.jsp](http://www.minicircuits.com/MCLStore/terms.jsp)



## Typical Performance Data

FREQUENCY (GHz)	INSERTION LOSS (dB)		Cross over isolation (dB) (between LPF and HPF)	RETURN LOSS (dB)		
	Lowpass port	Highpass port		Common port	Lowpass port	Highpass port
0.01	0.02	102.05	101.02	47.95	45.76	0.00
0.10	0.07	85.34	85.63	30.41	30.62	0.05
0.70	0.26	62.39	62.09	18.14	18.21	0.18
1.00	0.31	56.91	57.27	18.07	17.78	0.18
1.50	0.33	51.65	52.24	24.76	22.92	0.19
1.70	0.38	50.25	50.73	22.02	21.37	0.20
1.80	0.42	49.47	50.06	19.48	19.16	0.20
1.90	0.47	48.66	49.33	17.54	17.31	0.20
2.00	0.53	47.66	48.50	16.04	15.78	0.21
2.10	0.59	46.60	47.60	15.04	14.81	0.21
2.20	0.63	45.44	46.49	14.75	14.57	0.22
2.36	0.66	43.41	44.41	16.29	16.26	0.23
2.40	0.65	42.87	43.86	17.43	17.53	0.24
2.41	0.65	42.74	43.72	17.75	17.85	0.24
2.50	0.67	41.53	42.39	22.19	23.52	0.24
2.57	0.72	40.44	41.34	25.28	32.16	0.25
2.60	0.77	39.91	40.87	23.54	27.28	0.26
2.65	0.90	38.87	40.15	18.31	19.86	0.26
2.70	1.11	37.66	39.51	14.34	15.54	0.27
2.75	1.52	36.16	38.98	10.75	12.19	0.28
2.82	2.98	33.29	39.06	5.97	7.55	0.29
2.84	3.79	32.31	39.41	4.78	6.23	0.30
2.86	4.88	31.35	40.05	3.71	5.08	0.30
2.88	6.31	30.45	41.01	2.79	4.05	0.30
2.90	8.10	29.63	42.30	2.10	3.20	0.31
2.96	15.61	27.81	47.92	1.05	1.78	0.32
3.00	23.06	26.91	53.51	0.83	1.36	0.33
3.06	34.99	25.80	76.44	0.70	1.01	0.35
3.18	24.83	23.70	54.56	0.66	0.73	0.38
3.20	24.69	23.38	53.64	0.65	0.69	0.39
3.22	24.69	23.06	52.93	0.64	0.67	0.39
3.26	24.87	22.35	51.70	0.66	0.63	0.41
3.30	25.39	21.72	50.84	0.64	0.58	0.42
3.32	25.67	21.37	50.52	0.66	0.57	0.42
3.40	27.25	20.07	49.27	0.69	0.51	0.45
3.44	28.19	19.41	48.73	0.72	0.49	0.48
3.48	29.22	18.77	48.33	0.76	0.47	0.49
3.50	29.75	18.43	48.05	0.79	0.47	0.50
3.54	30.96	17.82	47.70	0.82	0.45	0.53
3.56	31.58	17.50	47.49	0.86	0.44	0.54
3.60	32.87	16.85	47.06	0.95	0.44	0.57
3.80	41.68	13.74	45.44	1.68	0.39	0.77
3.98	46.52	10.59	43.86	2.89	0.38	1.12
4.00	46.38	10.20	43.63	3.02	0.38	1.18
4.10	45.86	8.37	42.68	3.24	0.37	1.53
4.20	44.92	6.74	41.90	3.32	0.35	1.99
4.30	43.45	5.32	41.38	3.64	0.35	2.62
4.40	42.26	4.11	41.09	4.34	0.34	3.45
4.50	41.58	3.11	41.07	5.43	0.34	4.59
4.70	41.80	1.73	41.72	8.60	0.32	7.83
5.00	44.45	0.87	44.17	16.57	0.31	15.54
5.10	45.63	0.77	45.17	19.79	0.31	18.86
5.30	47.97	0.67	47.14	27.22	0.28	26.56
5.38	48.70	0.66	47.75	28.93	0.28	28.41
5.39	48.80	0.66	47.82	29.36	0.28	28.27
5.50	49.51	0.65	48.46	28.99	0.28	26.31
5.80	49.19	0.68	48.37	19.96	0.26	19.26
5.90	48.45	0.71	47.86	18.00	0.25	17.36
5.95	48.14	0.72	47.66	16.96	0.25	16.60
6.00	47.71	0.77	47.32	16.36	0.25	15.70

# Coaxial Diplexer

# ZDPLX-592-S+

## Typical Performance Curves

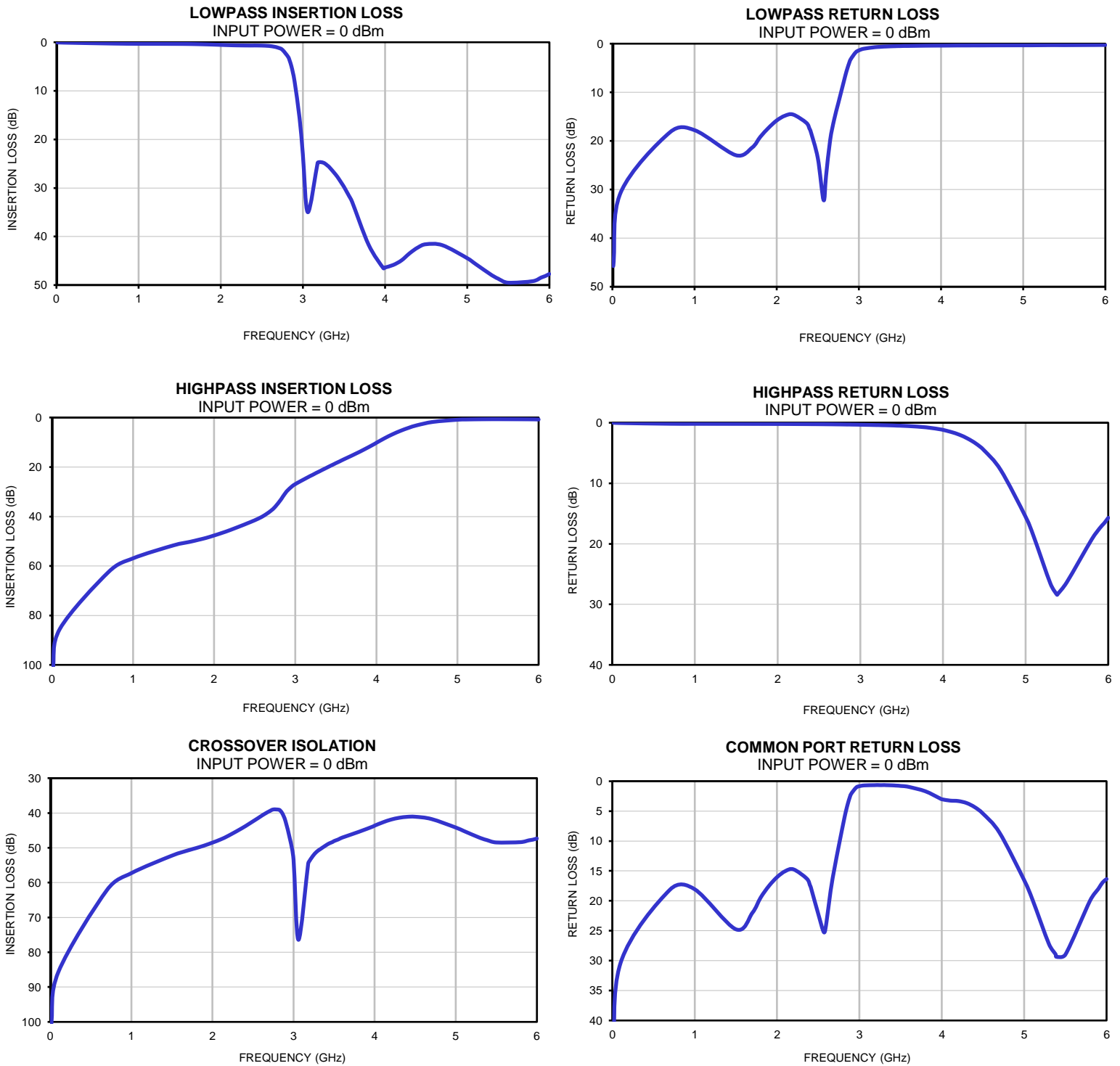

P.O. Box 350166, Brooklyn, New York 11235-0003 (718) 934-4500 • Fax (718) 332-4661 For detailed performance specs & shopping online see Mini-Circuits web site  
The Design Engineers Search Engine Provides ACTUAL Data Instantly From MINI-CIRCUITS At: [www.minicircuits.com](http://www.minicircuits.com)



IF/RF MICROWAVE COMPONENTS

REV. OR  
ZDPLX-592-S+  
140925  
Page 1 of 1

### Outline Dimensions

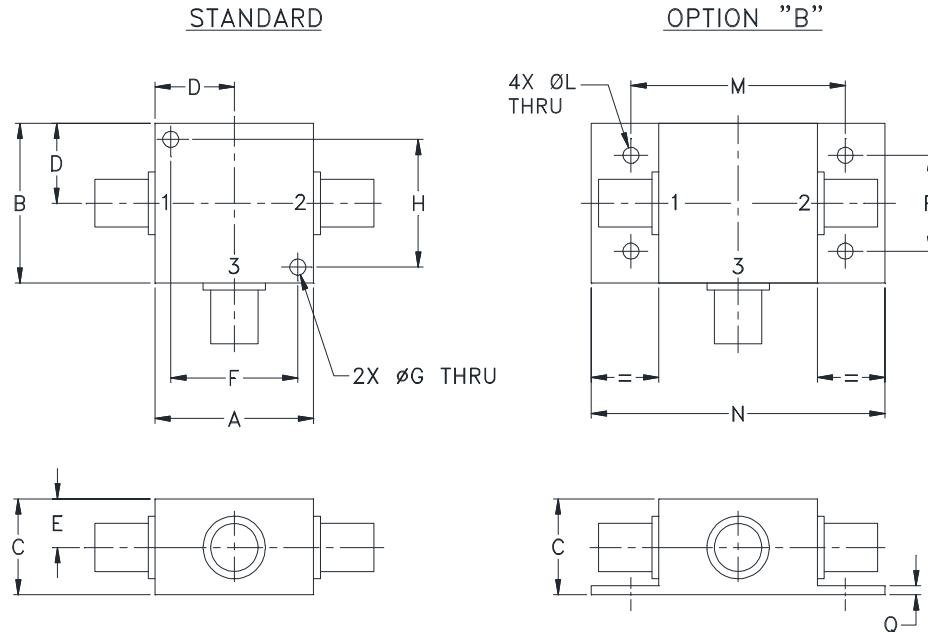

CASE#	A	B	C	D	E	F	G	H	J	K	L	M	N
K18	1.25 (31.75)	1.25 (31.75)	.75 (19.05)	.63 (16.00)	.38 (9.65)	1.000 (25.40)	.125 (3.18)	1.000 (25.40)	--	--	.125 (3.18)	1.688 (42.88)	2.18 (55.37)

CASE#	P	Q	WT. GRAMS
K18	.75 (19.05)	.07 (1.78)	70.0

Dimensions are in inches (mm). Tolerances: 2 Pl.  $\pm .03$ ; 3 Pl.  $\pm .015$

#### Notes:

- Case material: Aluminum alloy.
- Case finish:  
For RoHS Case Styles: Clear chemical conversion coating, non-chrome or trivalent chrome based.
- Mounting bracket available on request. Add suffix B to part number.
- For port marking 1, 2, and 3 see specifications data sheet.
- For bracket version, option B, dimension "C" changes from .75 to .94 inches when connectors are type N.
- Refer to the individual model data sheet for the type of connectors available.

**Mini-Circuits**<sup>®</sup>

INTERNET <http://www.minicircuits.com>

P.O. Box 350166, Brooklyn, New York 11235-0003 (718) 934-4500 Fax (718) 332-4661

Distribution Centers NORTH AMERICA 800-654-7949 • 417-335-5935 • Fax 417-335-5945 • EUROPE 44-1252-832600 • Fax 44-1252-837010

Mini-Circuits ISO 9001 & ISO 14001 Certified



All Mini-Circuits products are manufactured under exacting quality assurance and control standards, and are capable of meeting published specifications after being subjected to any or all of the following physical and environmental test.

Specification	Test/Inspection Condition	Reference/Spec
Operating Temperature	-40° to 85°C	Individual Model Data Sheet
Storage Temperature	-55° to 100° C Ambient Environment	Individual Model Data Sheet
Barometric Pressure	100,000 Feet	MIL-STD-202, Method 105, Condition D
Humidity	90% RH, 65°C Units may require bake-out after humidity to restore full performance.	MIL-STD-202, Method 103
Thermal Shock	-65° to 125°C, 5 cycles	MIL-STD-202, Method 107, Condition B
Vibration (High Frequency)	20g peak, 10-2000 Hz, 12 times in each of three perpendicular directions (total 36)	MIL-STD-202, Method 204, Condition D
Mechanical Shock	100g, 6ms sawtooth, 3 shocks each direction 3 axes (total 18)	MIL-STD-202, Method 213, Condition I