

Wideband, DC Pass Directional Coupler ZCDC20-E40653+

50Ω 20dB Up to 12W 40 to 65 GHz

The Big Deal

- Wideband, 40 to 65 GHz
- Power Handling up to 12W
- Excellent Coupling Flatness, ± 0.6 dB typ.



CASE STYLE: HT2536-3

Product Overview

The Mini-Circuits ZCDC20-E40653+ wideband directional coupler offers exceptional performance operating over 40 to 65 GHz. This coupler has excellent coupling flatness, good directivity, and power handling. It is ideal for lab testing applications as well as for power monitoring over wide bands, among other applications.

Key Features

Feature	Advantages
Wide bandwidth	With a bandwidth spanning 40 to 65 GHz, ZCDC20-E40653+ coupler is ideal for most lab testing applications, avoiding the need to switch components for different frequency bands.
Good Directivity • 15 dB typ. up to 65 GHz	High directivity allows sampling of input powers with minimal detrimental effects due to output mismatches.
Excellent Return Loss (In & Out) • 18 dB typ. up to 65 GHz	Excellent return loss over 40 to 65 GHz minimizes undesired reflections and resulting amplitude ripple.
• Excellent Coupling Flatness ± 0.6 dB typ,	Excellent coupling Flatness over the entire frequency range minimizes the need for compensation circuits in most applications.

Notes

- A. Performance and quality attributes and conditions not expressly stated in this specification document are intended to be excluded and do not form a part of this specification document.
B. Electrical specifications and performance data contained in this specification document are based on Mini-Circuit's applicable established test performance criteria and measurement instructions.
C. The parts covered by this specification document are subject to Mini-Circuits standard limited warranty and terms and conditions (collectively, "Standard Terms"); Purchasers of this part are entitled to the rights and benefits contained therein. For a full statement of the Standard Terms and the exclusive rights and remedies thereunder, please visit Mini-Circuits' website at www.minicircuits.com/MCLStore/terms.jsp



Wideband, DC Pass Directional Coupler

ZCDC20-E40653+

50Ω 20dB Up to 12W 40 to 65 GHz



Generic photo used for illustration purposes only

CASE STYLE: HT2536-3

Connectors	Model
1.85mm-Fem	ZCDC20-E40653+

Maximum Ratings

Operating Temperature	-55°C to 100°C
Storage Temperature	-55°C to 100°C
Supplied Termination*	1 W
DC Current	0.363 A

Permanent damage may occur if any of these limits are exceeded
* up to 25°C derates linearly to 325mW at 100°C.

Coaxial Connections

INPUT	IN
OUTPUT	OUT
COUPLED	CPL
TERMINATION (50Ω) INCLUDED	—

Outline Drawing

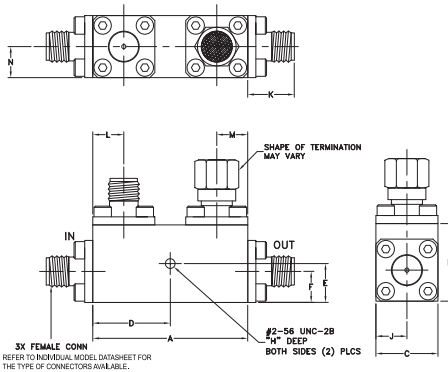

Outline Dimensions (inch/mm)

A	B	C	D	E	F	G
1.25	0.63	0.50	6.25	0.313	0.25	--
31.75	16.00	12.70	158.75	7.95	6.35	--
H	J	K	L	M	N	wt
0.120	0.25	0.43	0.25	0.25	0.25	grams
3.05	6.35	11	6.35	6.35	6.35	50

Electrical Schematic

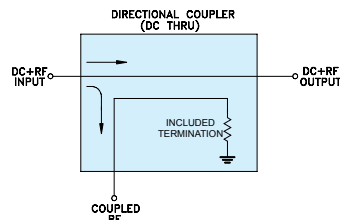

ZCDC20-E40653+ MAINLINE LOSS

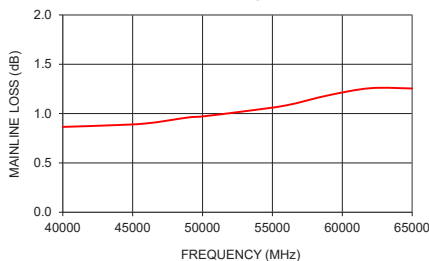

ZCDC20-E40653+ COUPLING & DIRECTIVITY

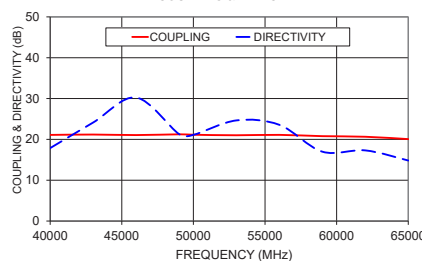

ZCDC20-E40653+ RETURN LOSS

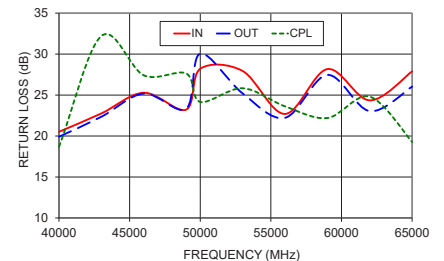

Notes

- Performance and quality attributes and conditions not expressly stated in this specification document are intended to be excluded and do not form a part of this specification document.
- Electrical specifications and performance data contained in this specification document are based on Mini-Circuit's applicable established test performance criteria and measurement instructions.
- The parts covered by this specification document are subject to Mini-Circuits standard limited warranty and terms and conditions (collectively, "Standard Terms"); Purchasers of this part are entitled to the rights and benefits contained therein. For a full statement of the Standard Terms and the exclusive rights and remedies thereunder, please visit Mini-Circuits' website at www.minicircuits.com/MCLStore/terms.jsp

Features

- Wide frequency range, 40 to 65 GHz
- Excellent coupling flatness, ± 0.6 dB typ. up to 65 GHz
- Good directivity, 15 dB typ. up to 65 GHz
- Excellent in/out return loss, 18 dB typ. up to 65 GHz
- DC current pass through input to output

Applications

- 5G
- mobile
- fixed satellite
- lab use

Electrical Specifications at 25°C

Parameter	Frequency (GHz)	Min.	Typ.	Max.	Units
Operating Frequency		40		65	GHz
Coupling	40 - 50	18.2	21.2	21.8	dB
	50 - 65	18.2	21.0	21.8	
Coupling Flatness (\pm)	40 - 65		0.6	1.0	dB
Mainline Loss ¹	40 - 50		0.9	1.6	dB
	50 - 65		1.1	2.0	
Directivity	40 - 50	8.0	23.5		dB
	50 - 65	7.0	20.1		
Return Loss (In & Out)	40 - 50	10.9	24.1		dB
	50 - 65	10.2	25.9		
Return Loss (Coupling)	40 - 50	10.9	24.8		dB
	50 - 65	10.2	23.8		
Input Power ²	40 - 65			12	W

1. Mainline loss includes coupling loss
2. Up to 25°C, derates linearly to 6.6W at 100°C.

Typical Performance Data

Frequency (MHz)	Mainline Loss (dB) In-Out	Coupling (dB) In-Cpl	Directivity (dB)	Return Loss (dB)		
				In	Out	Cpl
40000	0.87	21.10	17.87	20.52	19.91	18.69
43000	0.88	21.19	24.13	22.76	22.35	32.21
46000	0.90	21.06	30.25	25.28	25.18	27.41
49000	0.96	21.24	21.29	23.22	23.32	27.64
50000	0.97	21.14	21.11	28.21	30.06	24.16
53000	1.02	21.01	24.65	27.94	25.20	25.83
56000	1.08	21.11	23.56	22.69	22.22	23.62
59000	1.19	20.79	16.99	28.17	27.46	22.20
62000	1.26	20.64	17.30	24.35	23.03	24.80
65000	1.25	20.06	14.82	27.90	26.03	19.28

Directional Coupler

ZCDC20-E40653+

Typical Performance Data

FREQ. (MHz)	INSERTION LOSS ⁽¹⁾ (dB)	COUPLING (dB)	DIRECTIVITY (dB)	RETURN LOSS (dB)		
				IN	OUT	CPL
40000	0.99	20.85	14.91	22.46	22.34	18.78
40500	1.03	20.98	20.44	19.39	19.17	23.22
41000	1.05	20.98	23.26	18.86	18.78	32.61
41500	1.04	21.03	19.75	21.21	21.89	22.44
42000	1.02	21.05	19.69	28.15	32.63	20.05
42500	1.04	21.10	23.75	25.76	25.30	22.10
43000	1.07	21.08	28.26	21.09	21.15	35.35
43500	1.10	21.03	19.05	19.14	19.88	22.90
44000	1.10	20.91	15.28	19.83	21.05	18.06
44500	1.09	20.81	14.58	24.13	25.60	18.18
45000	1.10	20.84	15.51	33.32	37.54	22.46
45500	1.11	20.95	17.60	24.77	25.05	37.89
46000	1.12	21.01	20.07	21.73	22.96	27.75
46500	1.14	20.99	17.84	23.93	24.47	23.17
47000	1.14	20.95	15.67	31.46	26.60	24.75
47500	1.17	20.94	15.04	26.35	24.70	28.24
48000	1.18	21.00	15.46	21.29	21.71	32.01
48500	1.20	21.08	15.90	19.82	20.51	35.78
49000	1.21	21.10	16.48	21.59	22.49	33.78
49500	1.21	21.04	17.01	24.25	30.34	37.72
50000	1.22	20.97	17.68	24.41	32.36	26.70
50500	1.24	21.00	19.55	23.57	23.09	24.52
51000	1.25	20.94	22.32	22.34	20.15	28.13
51500	1.26	20.88	20.28	22.71	21.00	27.38
52000	1.27	20.96	17.03	25.92	26.32	27.40
52500	1.26	20.85	15.79	29.47	34.95	27.67
53000	1.27	20.80	14.94	35.63	29.06	26.35
53500	1.28	20.82	13.81	28.35	27.68	25.63
54000	1.30	20.83	13.15	26.45	28.65	23.05
54500	1.31	20.86	12.99	26.81	36.19	23.29
55000	1.33	20.91	13.49	32.19	34.25	24.03
55500	1.35	20.90	14.04	25.07	22.95	27.02
56000	1.38	20.91	16.05	20.54	20.06	26.71
56500	1.41	20.89	17.99	18.47	18.96	31.46
57000	1.41	20.79	16.98	19.29	20.93	27.72
57500	1.42	20.70	14.58	23.21	26.16	24.82
58000	1.44	20.65	12.65	31.60	37.67	23.28
58500	1.44	20.53	11.84	33.87	29.77	21.17
59000	1.44	20.56	12.93	28.25	26.39	21.47
59500	1.48	20.62	14.95	27.93	24.95	25.66
60000	1.53	20.70	16.29	29.62	24.66	26.17
60500	1.50	20.58	14.15	28.47	26.30	24.19
61000	1.52	20.44	12.16	26.72	28.40	22.65
61500	1.52	20.19	10.93	25.45	26.04	27.36
62000	1.52	20.24	11.26	27.25	28.15	25.43
62500	1.53	20.37	12.02	30.12	32.83	25.15
63000	1.54	20.31	11.69	32.17	33.44	31.23
63500	1.55	20.11	10.00	29.14	35.21	28.64
64000	1.58	19.79	8.68	33.56	33.80	22.23
64500	1.59	19.72	8.40	30.20	27.49	16.23
65000	1.60	19.87	9.64	22.79	21.28	15.38

⁽¹⁾ Mainline loss includes coupling loss



P.O. Box 350166, Brooklyn, New York 11235-0003 (718) 934-4500 • Fax (718) 332-4661 For detailed performance specs & shopping online see Mini-Circuits web site



The Design Engineers Search Engine Provides ACTUAL Data Instantly From MINI-CIRCUITS At: www.minicircuits.com

IF/RF MICROWAVE COMPONENTS

REV. OR

ZCDC20-E40653+

3/12/2021

Page 1 of 1

Directional Coupler

Typical Performance Curves

ZCDC20-E40653+

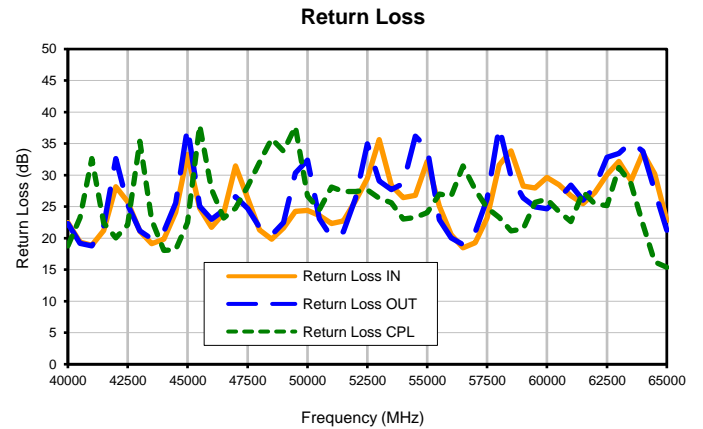
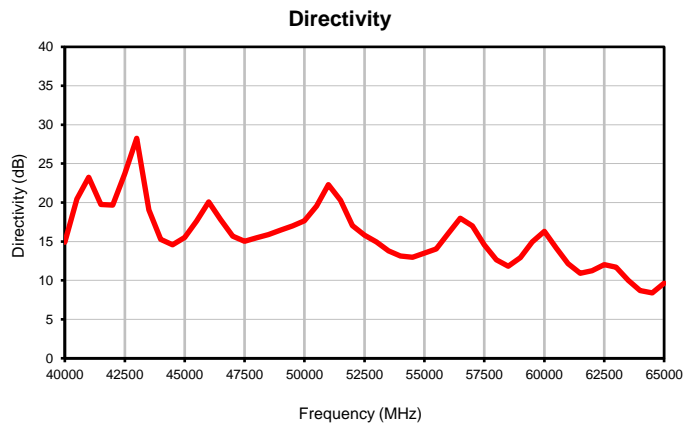
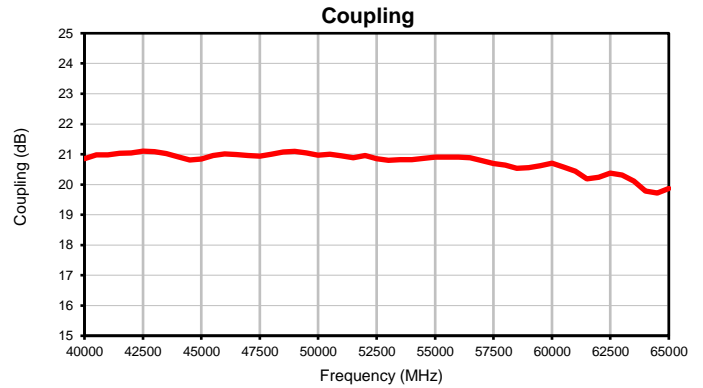
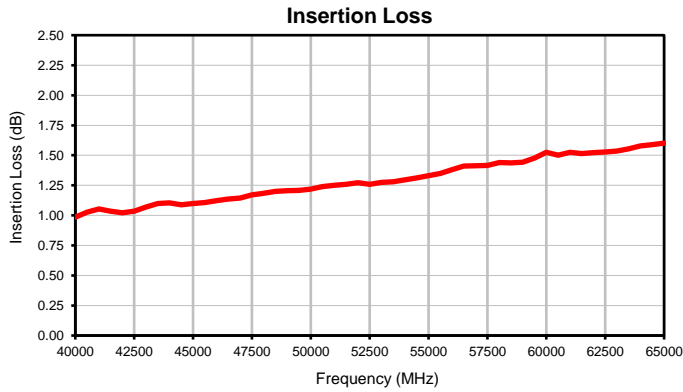

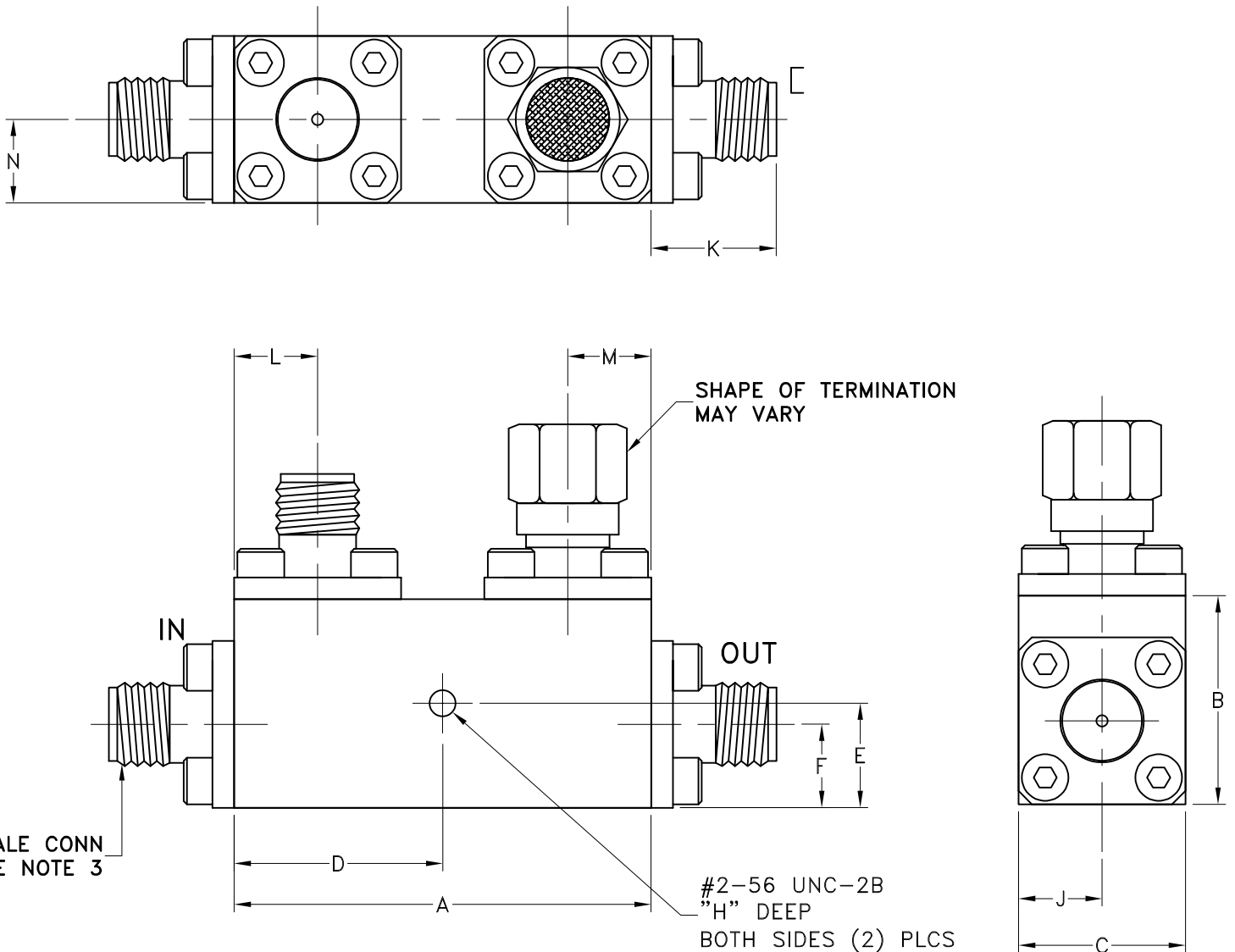

CASE#	A	B	C	D	E	F	G	H	J	K	L	M	N	WT. GRAMS
HT2536-3	1.25 (31.75)	.63 (15.9)	.50 (12.7)	.625 (15.88)	.313 (7.95)	.25 (6.35)	-	.120 (3.05)	.25 (6.35)	0.47 (12.0)	.25 (6.35)	.25 (6.35)	.25 (6.35)	45

Dimensions are in inches (mm). Tolerances: 2 Pl.±.03; 3 Pl. ±.015

Notes:

1. Case material: Aluminum Alloy.
2. Finish: Nickel Plating.
3. Refer to the individual model data sheet for the types of connectors available.



P.O. Box 350166, Brooklyn, New York 11235-0003 (718) 934-4500 Fax (718) 332-4661 For detailed performance specs & shopping online see Mini-Circuits web site



The Design Engineers Search Engine Provides ACTUAL Data Instantly From MINI-CIRCUITS At: www.minicircuits.com

RF/IF MICROWAVE COMPONENTS



All Mini-Circuits products are manufactured under exacting quality assurance and control standards, and are capable of meeting published specifications after being subjected to any or all of the following physical and environmental test.

Specification	Test/Inspection Condition	Reference/Spec
Operating Temperature	-55° to 100°C Ambient Environment	Individual Model Data Sheet
Storage Temperature	-55° to 100° C Ambient Environment	Individual Model Data Sheet
Barometric Pressure	100,000 Feet	MIL-STD-202, Method 105, Condition D
Humidity	90% RH, 65°C Units may require bake-out after humidity to restore full performance.	MIL-STD-202, Method 103
Thermal Shock	-65° to 125°C, 5 cycles	MIL-STD-202, Method 107, Condition B
Vibration (High Frequency)	20g peak, 10-2000 Hz, 12 times in each of three perpendicular directions (total 36)	MIL-STD-202, Method 204, Condition D
Mechanical Shock	100g, 6ms sawtooth, 3 shocks each direction 3 axes (total 18)	MIL-STD-202, Method 213, Condition I