

Wideband, DC Pass

Directional Coupler

ZCDC10-01203-S+

50Ω 10dB Up to 20W 1 to 20 GHz

The Big Deal

- Wideband, 1 to 20 GHz
- Power Handling up to 20W



CASE STYLE: HT2626-1

Product Overview

The Mini-Circuits ZCDC10-01203-S+ wideband directional coupler offers exceptional performance operating over 1 to 20 GHz. This coupler has excellent coupling flatness, good directivity, and power handling. It is ideal for lab testing applications as well as for power monitoring over wide bands, among other applications.

Key Features

Feature	Advantages
Wide bandwidth	With a bandwidth spanning 1 to 20 GHz, ZCDC10-01203-S+ coupler is ideal for most lab testing applications, avoiding the need to switch components for different frequency bands.
Good Directivity • 15 dB typ. up to 20 GHz	High directivity allows sampling of input powers with minimal detrimental effects due to output mismatches.
Good Return Loss (In & Out) • 21 dB typ. up to 20 GHz	Good return loss over 1 to 20 GHz minimizes undesired reflections and resulting amplitude ripple.

Notes

- A. Performance and quality attributes and conditions not expressly stated in this specification document are intended to be excluded and do not form a part of this specification document.
B. Electrical specifications and performance data contained in this specification document are based on Mini-Circuit's applicable established test performance criteria and measurement instructions.
C. The parts covered by this specification document are subject to Mini-Circuits standard limited warranty and terms and conditions (collectively, "Standard Terms"); Purchasers of this part are entitled to the rights and benefits contained therein. For a full statement of the Standard Terms and the exclusive rights and remedies thereunder, please visit Mini-Circuits' website at www.minicircuits.com/MCLStore/terms.jsp



Wideband, DC Pass Directional Coupler

ZCDC10-01203-S+

50Ω 10dB Up to 20W 1 to 20 GHz

Maximum Ratings

Operating Temperature	-55°C to 100°C
Storage Temperature	-55°C to 100°C
Supplied Termination*	1 W
DC Current	0.63A

Permanent damage may occur if any of these limits are exceeded
* up to 25°C, derates linearly to 325mW at 100°C.

Coaxial Connections

INPUT	IN
OUTPUT	OUT
COUPLED	CPL
TERMINATION (50Ω) INCLUDED	—

Outline Drawing

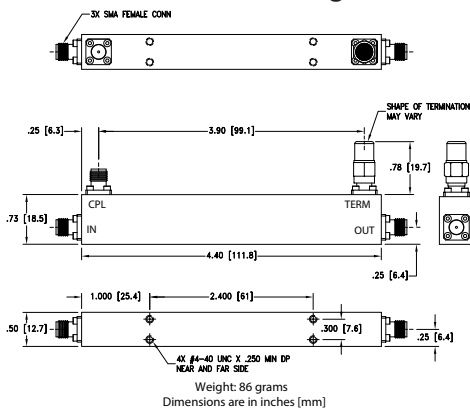

Electrical Schematic

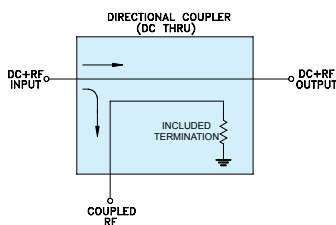

Features

- Wide frequency range, 1 to 20 GHz
- Good coupling flatness, ±0.5 dB typ. up to 18 GHz, 0.6 dB typ. up to 20 GHz
- Good directivity, 15 dB typ. up to 20 GHz
- Good return loss, 21 dB typ. up to 20 GHz
- DC current pass through input to output

Applications

- 5G
- mobile
- fixed satellite
- lab use



Generic photo used for illustration purposes only
CASE STYLE: HT2626-1

Connectors	Model
SMA Female	ZCDC10-01203-S+

+RoHS Compliant

The +Suffix identifies RoHS Compliance. See our web site for RoHS Compliance methodologies and qualifications

Electrical Specifications at 25°C

Parameter	Frequency (GHz)	Min.	Typ.	Max.	Units
Operating Frequency		1		20	GHz
Coupling	1 - 20	-	10±1.2	-	dB
Coupling Flatness (±)	1 - 18	-	±0.5	±1.2	dB
	18 - 20	-	±0.6	±1.5	dB
Mainline Loss ¹	1 - 20	-	1.00	2.05	dB
Directivity	1 - 20	12	23	-	dB
Return Loss (In & Out)	1 - 20	12.7	26	-	dB
Return Loss (Coupling)	1 - 20	10.8	24	-	dB
Input Power ²	1 - 20	-	-	20	W

1. Mainline loss includes coupling loss
2. Up to 25°C, derates linearly to 5W at 100°C.

Typical Performance Data

Frequency (MHz)	Mainline Loss ¹ (dB) In-Out	Coupling (dB) In-Cpl	Directivity (dB)	Return Loss (dB)		
				In	Out	Cpl
1000	0.56	10.24	24.04	31.67	28.25	25.56
2000	0.67	9.91	24.80	26.08	25.07	27.87
3000	0.70	10.11	30.33	23.87	23.25	24.71
4000	0.76	9.99	45.43	23.50	22.72	21.88
6000	0.83	10.10	20.75	22.65	25.86	23.56
8000	0.83	10.53	22.29	31.47	33.62	16.61
10000	0.94	10.40	22.14	22.76	22.28	23.43
12000	1.06	9.98	17.88	24.50	29.00	31.78
14000	1.13	10.36	20.63	22.24	23.36	15.36
16000	1.17	10.51	17.41	30.24	34.53	18.58
18000	1.25	10.77	19.30	24.62	23.30	23.22
20000	1.37	11.00	14.94	20.78	20.82	17.46

1. Mainline loss includes coupling loss

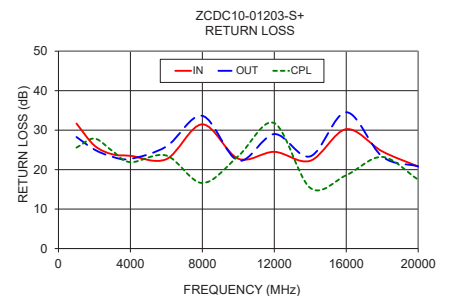
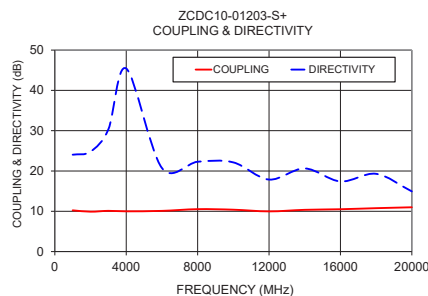
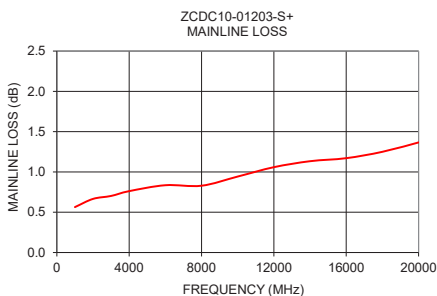

Notes

- Performance and quality attributes and conditions not expressly stated in this specification document are intended to be excluded and do not form a part of this specification document.
- Electrical specifications and performance data contained in this specification document are based on Mini-Circuit's applicable established test performance criteria and measurement instructions.
- The parts covered by this specification document are subject to Mini-Circuit's standard limited warranty and terms and conditions (collectively, "Standard Terms"); Purchasers of this part are entitled to the rights and benefits contained therein. For a full statement of the Standard Terms and the exclusive rights and remedies thereunder, please visit Mini-Circuit's website at www.minicircuits.com/MCLStore/terms.jsp



www.minicircuits.com P.O. Box 350166, Brooklyn, NY 11235-0003 (718) 934-4500 sales@minicircuits.com

REV. OR
ECO-0003309
ZCDC10-01203-S+
CM/CP/AM
200715
Page 2 of 2

Directional Coupler

ZCDC10-01203-S+

Typical Performance Data

FREQ. (MHz)	INSERTION LOSS ⁽¹⁾ (dB)	COUPLING (dB)	DIRECTIVITY (dB)	RETURN LOSS		
				(dB)		CPL
				IN	OUT	
500	0.50	10.44	28.71	27.71	27.10	25.42
550	0.53	10.18	28.43	28.14	27.47	26.10
600	0.55	10.02	27.96	28.95	28.33	26.87
650	0.57	9.94	27.41	30.06	29.55	27.81
700	0.57	9.93	26.86	31.46	31.45	28.55
750	0.57	9.97	26.12	33.33	33.27	28.78
800	0.57	10.03	25.41	35.92	33.28	28.64
850	0.56	10.10	24.90	37.40	31.90	27.96
900	0.56	10.16	24.42	36.52	30.34	27.03
950	0.56	10.21	24.14	34.06	29.00	26.22
1000	0.56	10.24	24.04	31.67	28.25	25.56
1500	0.67	9.66	25.96	26.38	24.55	24.99
2000	0.67	9.91	24.80	26.08	25.07	27.87
2500	0.67	10.08	26.04	27.64	26.71	25.84
3000	0.70	10.11	30.33	23.87	23.25	24.71
3500	0.69	10.26	26.39	30.07	28.45	31.35
4000	0.76	9.99	45.43	23.50	22.72	21.88
4500	0.72	10.43	27.17	33.00	29.09	22.37
5000	0.79	10.13	27.99	22.97	23.45	21.32
5500	0.74	10.58	30.02	39.63	32.32	16.91
6000	0.83	10.10	20.75	22.65	25.86	23.56
6500	0.85	10.18	28.36	27.66	25.92	17.46
7000	0.84	10.24	19.15	24.43	27.18	16.16
7500	0.89	10.09	18.84	21.91	22.08	41.90
8000	0.83	10.53	22.29	31.47	33.62	16.61
8500	0.93	10.24	16.26	19.80	21.53	20.55
9000	0.88	10.43	30.44	29.79	29.00	20.80
9500	0.95	10.09	17.11	22.55	24.85	20.87
10000	0.94	10.40	22.14	22.76	22.28	23.43
10500	0.95	10.25	18.52	29.26	34.57	18.92
11000	0.97	10.47	19.58	22.92	25.04	28.20
11500	0.99	10.38	24.60	29.19	30.73	16.98
12000	1.06	9.98	17.88	24.50	29.00	31.78
12400	1.05	10.17	30.89	27.71	29.46	15.50
12500	1.04	10.27	29.26	25.78	27.37	15.99
13000	1.13	9.83	19.59	31.87	34.93	18.98
13500	1.09	10.53	18.65	25.80	28.84	19.90
14000	1.13	10.36	20.63	22.24	23.36	15.36
14500	1.07	10.84	18.62	27.38	34.18	17.00
15000	1.17	10.47	19.14	20.41	22.27	17.01
15500	1.19	10.53	18.27	24.83	22.94	17.25
16000	1.17	10.51	17.41	30.24	34.53	18.58
16500	1.20	10.45	18.43	20.68	20.55	21.65
17000	1.19	10.80	16.79	22.02	20.93	21.32
17500	1.24	10.40	19.16	27.31	26.53	30.63
18000	1.25	10.77	19.30	24.62	23.30	23.22
18500	1.40	9.90	17.35	23.36	20.17	26.06
19000	1.31	10.72	31.55	28.05	29.57	14.69
19500	1.36	10.49	14.79	25.14	20.79	19.66
20000	1.37	11.00	14.94	20.78	20.82	17.46
20500	1.32	11.50	16.69	22.80	29.49	12.79
21000	1.47	10.42	12.12	20.89	19.52	22.46
21500	1.48	10.86	16.89	17.17	18.83	15.93
22000	1.50	10.47	9.51	27.70	24.98	20.93

⁽¹⁾ Mainline loss includes coupling loss



Directional Coupler

Typical Performance Curves

ZCDC10-01203-S+

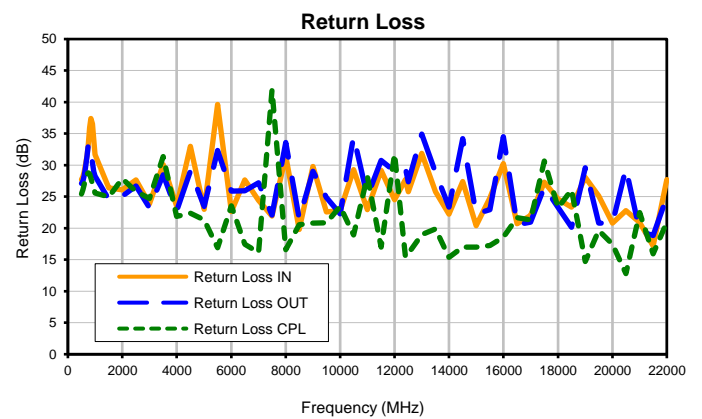
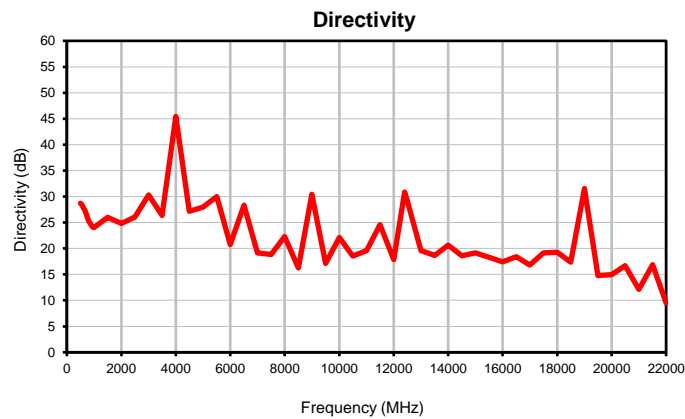
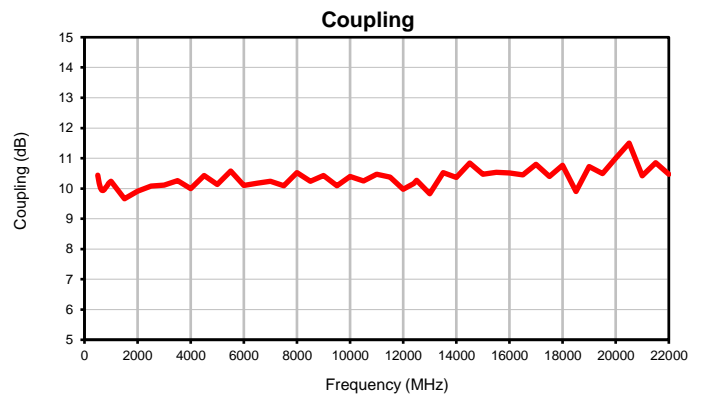
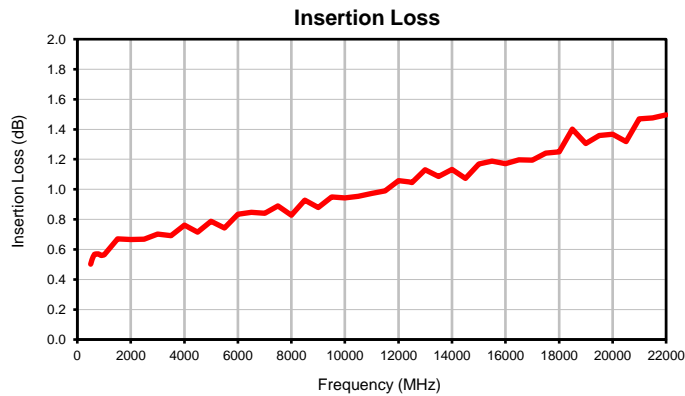

Case Style

Outline Dimensions

HT

HT2626-1

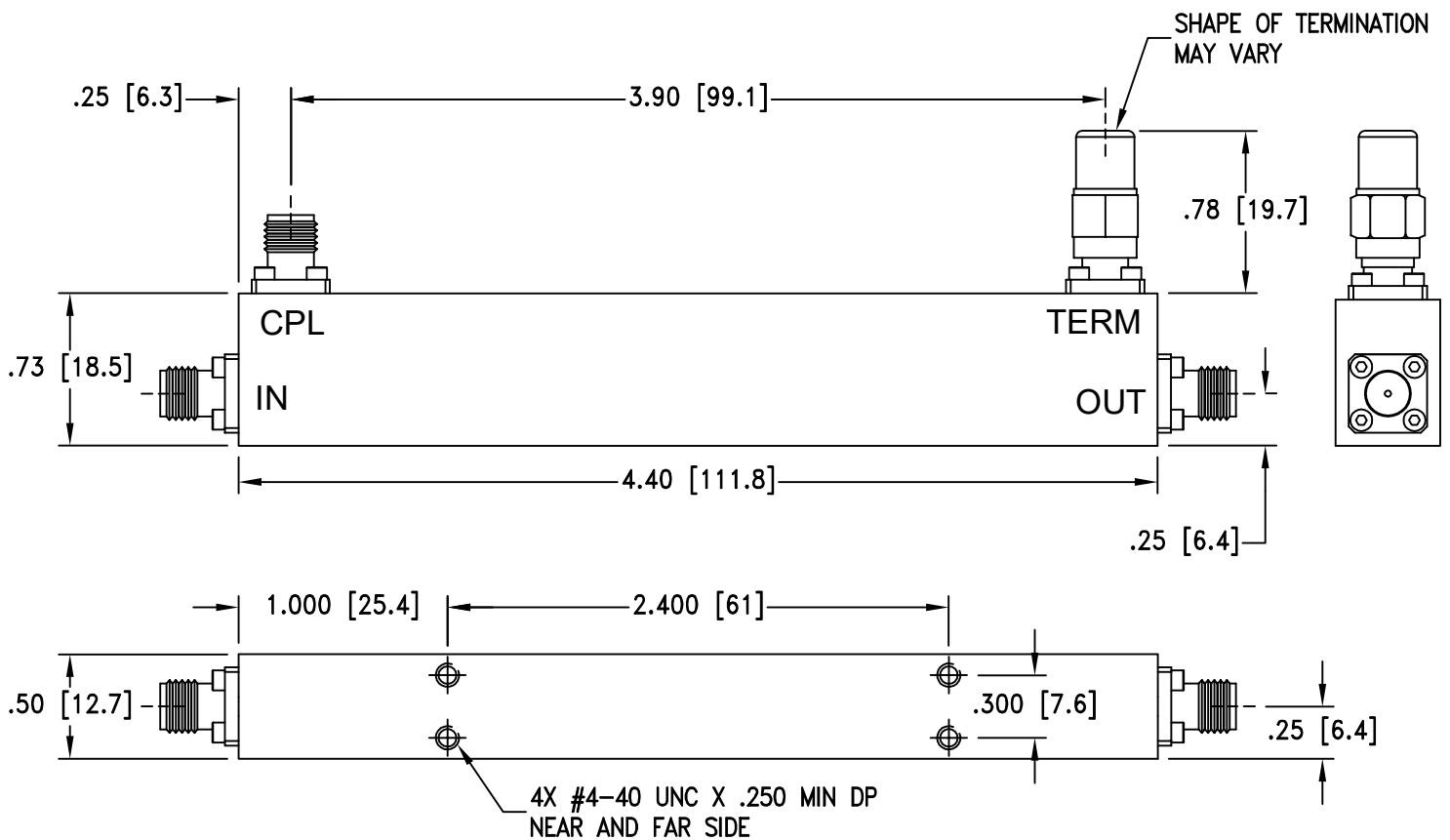

Weight: 86 grams

Dimensions are in inches (mm). Tolerances: 2 Pl. ± .03, 3 Pl. ± .015

Notes:

1. Case material: Aluminum Alloy 6061
2. Case Finish: Black Matte Paint

Mini-Circuits®
ISO 9001 ISO 14001 CERTIFIED

ALL NEW
minicircuits.com

P.O. Box 350166, Brooklyn, New York 11235-0003 (718) 934-4500 Fax (718) 332-4661 For detailed performance specs & shopping online see Mini-Circuits web site



The Design Engineers Search Engine Provides ACTUAL Data Instantly From MINI-CIRCUITS At: www.minicircuits.com

RF/IF MICROWAVE COMPONENTS



All Mini-Circuits products are manufactured under exacting quality assurance and control standards, and are capable of meeting published specifications after being subjected to any or all of the following physical and environmental test.

Specification	Test/Inspection Condition	Reference/Spec
Operating Temperature	-55° to +85 °C Ambient Environment	Individual Model Data Sheet
Storage Temperature	-55° to 100° C Ambient Environment	Individual Model Data Sheet
Thermal Shock	-55° to 100°C, 100 cycles	MIL-STD-202, Method 107, Condition A-3, except +100°C