

DC Pass, High Power

# Power Splitter/Combiner ZC4PD-06263-S+

4 Way-0° 50Ω 6000 to 26500 MHz

## The Big Deal

- Super wideband, 6 to 26.5 GHz
- Low insertion loss, 1.5 dB typ.
- High Isolation, 26 dB typ.
- 20W power handling
- Low amplitude unbalance, 0.13 dB typ.



CASE STYLE: UU2413-3

## Product Overview

Mini-Circuits' ZC4PD-06263-S+ is a super wideband 4-way 0° splitter/combiner providing coverage from 6 to 26.5 GHz, supporting a wide range of applications including 5G, Ku-Band, K-Band, instrumentation and many more. This model provides 20W power handling as a splitter and very low insertion loss across the entire operating frequency range, minimizing power dissipation and delivering excellent signal power transmission from input to output. The ZC4PD-06263-S+ comes housed in a case measuring 1.5 x 2.04 x 0.5".

## Key Features

Feature	Advantages
Ultra-wideband, 6 to 26.5 GHz	Extremely wide frequency range supports many broadband applications in a single model.
Low insertion loss, 1.5 dB typ. at 18 GHz	The combination of 20W power handling and low insertion loss makes this model a suitable candidate for distributing signals while maintaining excellent transmission of signal power.
High isolation, 26 dB typ. at 18 GHz	Minimizes interference between ports.
High power handling: <ul style="list-style-type: none"><li>• 20W as a splitter at 25°C</li><li>• 2W as a combiner</li></ul>	The ZC4PD-06263-S+ is suitable for systems with a wide range of power requirements.
Low amplitude unbalance, 0.13 dB at 18 GHz	Produces nearly equal output signals, ideal for parallel path and multichannel systems.
DC Passing, 530mA	Supports applications where DC power is needed through the RF line.

### Notes

- A. Performance and quality attributes and conditions not expressly stated in this specification document are intended to be excluded and do not form a part of this specification document.  
B. Electrical specifications and performance data contained in this specification document are based on Mini-Circuit's applicable established test performance criteria and measurement instructions.  
C. The parts covered by this specification document are subject to Mini-Circuits standard limited warranty and terms and conditions (collectively, "Standard Terms"); Purchasers of this part are entitled to the rights and benefits contained therein. For a full statement of the Standard Terms and the exclusive rights and remedies thereunder, please visit Mini-Circuits' website at [www.minicircuits.com/MCLStore/terms.jsp](http://www.minicircuits.com/MCLStore/terms.jsp)



# DC Pass, High Power Power Splitter/Combiner

## ZC4PD-06263-S+

4 Way-0° 50Ω 6000 to 26500 MHz

### Maximum Ratings

Operating Temperature	-55°C to 100°C
Storage Temperature	-55°C to 100°C
Power Input (as a splitter)	20W* max.
Internal Dissipation	2W max.
DC Pass	530mA

Permanent damage may occur if any of these limits are exceeded.  
\*Derates linearly to 14W at 100°C

### Coaxial Connections

Sum Port	S
Port 1	1
Port 2	2
Port 3	3
Port 4	4

### Outline Drawing

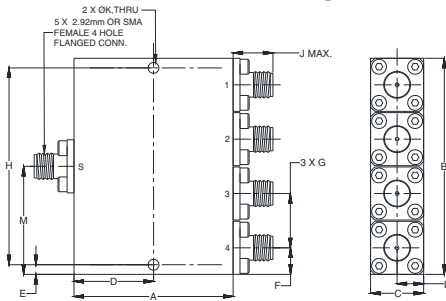

### Outline Dimensions (inch/mm)

A	B	C	D	E	F	G
1.50	2.04	.50	.750	0.091	.25	.51
38.10	51.82	12.70	19.05	2.31	6.35	13.0
H	J	K	L	M	wt	
1.854	.43	.100	.25	1.02	grams	
47.1	11	2.54	6.35	25.91	110	

### Electrical Schematic

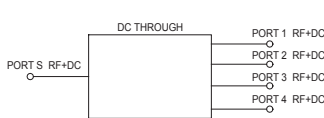

### Features

- Super wideband, 6000 to 26500 MHz
- Low insertion loss, 1.5 dB typ.
- Low amplitude unbalance, 0.13 dB typ.
- Excellent VSWR, 1.2:1 typ.
- High isolation, 26 dB typ.

### Applications

- 5G
- Fixed satellite
- Space research
- Mobile



Generic photo used for illustration purposes only

CASE STYLE: UU2413-3

Connectors	Model
SMA-Fem	ZC4PD-06263-S+

**+RoHS Compliant**  
The +Suffix identifies RoHS Compliance. See our web site for RoHS Compliance methodologies and qualifications

### Electrical Specifications at 25°C

Parameter	Frequency (MHz)	Min.	Typ.	Max.	Unit
Frequency Range		6000		26500	MHz
Insertion Loss Above 6.0 dB	6000 - 18000	—	1.0	1.5	dB
	18000 - 26500	—	1.5	1.9	
Isolation	6000 - 18000	16	24	—	dB
	18000 - 26500	17	26	—	
Phase Unbalance (±) <sup>1</sup>	6000 - 18000	—	1.4	4	Degree
	18000 - 26500	—	2	6	
Amplitude Unbalance (±) <sup>1</sup>	6000 - 18000	—	0.09	0.3	dB
	18000 - 26500	—	0.13	0.4	
VSWR (Port S)	6000 - 18000	—	1.34	1.7	:1
	18000 - 26500	—	1.20	1.6	
VSWR (Port 1-4)	6000 - 18000	—	1.29	1.7	:1
	18000 - 26500	—	1.23	1.6	

1. With reference to average.

### Typical Performance Data

Freq. (MHz)	Total Loss <sup>1</sup> (dB)				Amp. Unb. (dB)	Isolation (dB)			Phase Unb. (deg.)	VSWR S	VSWR 1	VSWR 2	VSWR 3	VSWR 4
	S-1	S-2	S-3	S-4		1-2	1-4	3-4						
6000	6.53	6.57	6.56	6.59	0.06	25.91	26.54	24.47	1.32	1.06	1.26	1.24	1.25	1.25
7000	6.57	6.61	6.59	6.61	0.04	24.97	32.76	22.94	1.43	1.04	1.09	1.10	1.05	1.05
8000	6.62	6.66	6.69	6.72	0.10	24.21	40.28	24.79	1.31	1.12	1.02	1.02	1.06	1.06
9000	6.68	6.72	6.70	6.74	0.05	28.74	35.46	31.23	1.26	1.10	1.18	1.18	1.17	1.17
10000	6.72	6.76	6.75	6.79	0.07	24.42	31.38	22.72	1.38	1.05	1.13	1.11	1.13	1.15
11000	6.78	6.82	6.82	6.86	0.08	30.30	30.53	28.52	1.64	1.05	1.22	1.22	1.26	1.26
12000	6.84	6.89	6.87	6.90	0.06	30.83	33.62	35.07	1.53	1.15	1.07	1.07	1.05	1.04
13000	6.89	6.94	6.91	6.95	0.06	28.19	50.07	26.71	1.70	1.15	1.18	1.18	1.17	1.17
14000	6.92	6.97	6.96	6.99	0.07	27.54	34.33	27.24	1.35	1.11	1.12	1.13	1.15	1.12
15000	6.97	7.02	7.00	7.04	0.07	46.31	30.44	38.03	1.42	1.10	1.17	1.13	1.14	1.17
16000	7.08	7.13	7.08	7.12	0.05	26.43	31.94	24.69	1.52	1.24	1.18	1.16	1.20	1.21
18000	7.13	7.18	7.19	7.22	0.09	33.52	35.91	37.15	1.57	1.16	1.28	1.27	1.29	1.28
20000	7.29	7.34	7.30	7.34	0.06	27.45	36.32	26.62	1.53	1.25	1.04	1.09	1.11	1.06
22000	7.42	7.52	7.46	7.48	0.10	37.19	34.10	37.59	1.43	1.09	1.19	1.15	1.11	1.14
26500	7.54	7.63	7.61	7.66	0.12	34.31	35.86	33.10	2.03	1.14	1.18	1.20	1.20	1.14

1. Total Loss = Insertion Loss + 6dB splitter theoretical loss.

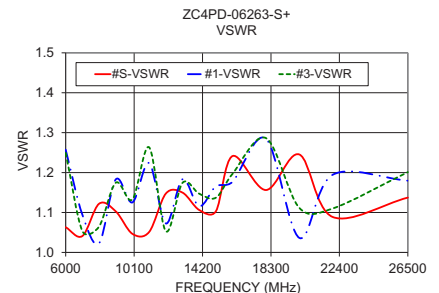
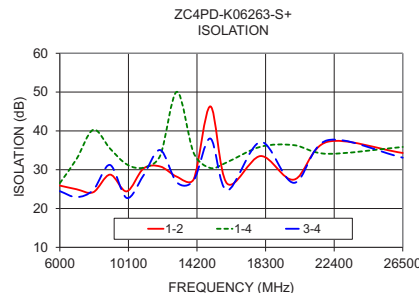
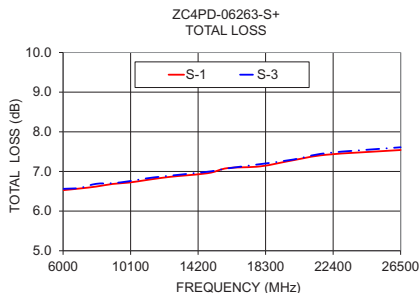

### Notes

- Performance and quality attributes and conditions not expressly stated in this specification document are intended to be excluded and do not form a part of this specification document.
- Electrical specifications and performance data contained in this specification document are based on Mini-Circuit's applicable established test performance criteria and measurement instructions.
- The parts covered by this specification document are subject to Mini-Circuit's standard limited warranty and terms and conditions (collectively, "Standard Terms"); Purchasers of this part are entitled to the rights and benefits contained therein. For a full statement of the Standard Terms and the exclusive rights and remedies thereunder, please visit Mini-Circuit's website at [www.minicircuits.com/MCLStore/terms.jsp](http://www.minicircuits.com/MCLStore/terms.jsp)



[www.minicircuits.com](http://www.minicircuits.com) P.O. Box 350166, Brooklyn, NY 11235-0003 (718) 934-4500 sales@minicircuits.com

REV. A  
ECO-005034  
ZC4PD-06263-S+  
GY/CP/AM  
201120  
Page 2 of 2

# 4 Way-0° Power Splitter/Combiner

# ZC4PD-06263-S+

## Typical Performance Data

TEST CONDITIONS: INPUT POWER = 0 dBm @Temperature = +25°C

FREQ. (MHz)	TOTAL LOSS <sup>1</sup> (dB)				AMP. UNBAL. (dB)	PHASE UNBAL. (deg.)	ISOLATION (dB)			VSWR (:1)				
	S-1	S-2	S-3	S-4			1-2	1-4	3-4	S	1	2	3	4
5000	6.46	6.50	6.54	6.57	0.11	1.06	15.11	23.06	15.33	1.14	1.22	1.22	1.25	1.25
6000	6.53	6.57	6.56	6.59	0.06	1.32	25.91	26.54	24.47	1.06	1.26	1.24	1.25	1.25
6500	6.52	6.56	6.59	6.62	0.10	1.37	21.52	29.32	20.26	1.04	1.05	1.04	1.05	1.06
7000	6.57	6.61	6.59	6.61	0.04	1.43	24.97	32.76	22.94	1.04	1.09	1.10	1.05	1.05
7500	6.59	6.63	6.63	6.66	0.07	1.20	26.74	37.75	25.81	1.08	1.07	1.07	1.07	1.07
8000	6.62	6.66	6.69	6.72	0.10	1.31	24.21	40.28	24.79	1.12	1.02	1.02	1.06	1.06
8500	6.67	6.71	6.71	6.74	0.07	1.57	23.18	38.97	24.35	1.17	1.13	1.13	1.13	1.13
9000	6.68	6.72	6.70	6.74	0.05	1.26	28.74	35.46	31.23	1.10	1.18	1.18	1.17	1.17
9500	6.68	6.72	6.73	6.77	0.09	1.38	32.36	32.94	28.45	1.05	1.15	1.13	1.17	1.18
10000	6.72	6.76	6.75	6.79	0.07	1.38	24.42	31.38	22.72	1.05	1.13	1.11	1.13	1.15
10500	6.75	6.78	6.81	6.84	0.10	1.50	25.22	30.64	23.40	1.09	1.11	1.09	1.15	1.16
11000	6.78	6.82	6.82	6.86	0.08	1.64	30.30	30.53	28.52	1.05	1.22	1.22	1.26	1.26
11500	6.86	6.92	6.90	6.93	0.06	1.60	30.67	31.66	34.83	1.28	1.20	1.22	1.23	1.21
12000	6.84	6.89	6.87	6.90	0.06	1.53	30.83	33.62	35.07	1.15	1.07	1.07	1.05	1.04
12500	6.89	6.93	6.93	6.96	0.07	1.56	43.21	38.39	33.08	1.23	1.22	1.21	1.20	1.19
13000	6.89	6.94	6.91	6.95	0.06	1.70	28.19	50.07	26.71	1.15	1.18	1.18	1.17	1.17
13500	6.93	6.99	6.93	6.96	0.06	1.55	25.16	40.16	24.95	1.18	1.11	1.12	1.14	1.12
14000	6.92	6.97	6.96	6.99	0.07	1.35	27.54	34.33	27.24	1.11	1.12	1.13	1.15	1.12
14500	6.98	7.03	7.02	7.05	0.07	1.54	31.11	31.56	30.00	1.25	1.04	1.06	1.05	1.02
15000	6.97	7.02	7.00	7.04	0.07	1.42	46.31	30.44	38.03	1.10	1.17	1.13	1.14	1.17
15500	7.09	7.14	7.13	7.16	0.07	1.76	30.57	30.89	29.59	1.38	1.30	1.27	1.30	1.31
16000	7.08	7.13	7.08	7.12	0.05	1.52	26.43	31.94	24.69	1.24	1.18	1.16	1.20	1.21
16500	7.12	7.17	7.17	7.20	0.08	1.41	26.82	36.10	25.01	1.35	1.35	1.32	1.34	1.34
17000	7.22	7.27	7.26	7.29	0.07	1.67	27.54	43.11	28.54	1.40	1.36	1.35	1.36	1.34
17500	7.13	7.17	7.15	7.19	0.05	1.46	30.31	43.70	35.94	1.14	1.26	1.24	1.24	1.23
18000	7.13	7.18	7.19	7.22	0.09	1.57	33.52	35.91	37.15	1.16	1.28	1.27	1.29	1.28
18500	7.18	7.23	7.23	7.25	0.07	1.58	33.47	33.79	35.24	1.17	1.25	1.24	1.27	1.26
19000	7.19	7.26	7.25	7.27	0.08	1.60	34.94	32.67	32.90	1.25	1.14	1.16	1.20	1.17
19500	7.19	7.27	7.25	7.28	0.09	1.66	27.04	33.31	26.32	1.16	1.05	1.08	1.11	1.08
20000	7.29	7.34	7.30	7.34	0.06	1.53	27.45	36.32	26.62	1.25	1.04	1.09	1.11	1.06
20500	7.26	7.30	7.28	7.33	0.07	1.70	37.84	41.16	35.26	1.17	1.11	1.07	1.06	1.09
21000	7.29	7.34	7.32	7.37	0.08	1.91	35.83	39.50	33.06	1.10	1.12	1.07	1.05	1.10
21500	7.34	7.40	7.40	7.43	0.09	2.02	36.17	35.02	31.93	1.18	1.21	1.16	1.11	1.16
22000	7.42	7.52	7.46	7.48	0.10	1.43	37.19	34.10	37.59	1.09	1.19	1.15	1.11	1.14
22500	7.40	7.47	7.47	7.50	0.10	1.78	38.10	33.14	43.37	1.16	1.18	1.13	1.10	1.14
23000	7.41	7.48	7.44	7.47	0.07	2.12	31.78	33.10	33.33	1.11	1.13	1.08	1.07	1.11
23500	7.41	7.49	7.44	7.48	0.08	2.02	31.27	35.47	34.44	1.15	1.12	1.08	1.08	1.11
24000	7.40	7.46	7.45	7.51	0.11	2.14	42.77	42.19	39.06	1.05	1.05	1.06	1.08	1.09
24500	7.40	7.49	7.43	7.46	0.10	2.15	28.58	65.95	27.53	1.06	1.04	1.03	1.05	1.04
25000	7.44	7.52	7.50	7.55	0.11	1.99	29.48	41.54	28.34	1.14	1.07	1.10	1.13	1.11
25500	7.41	7.49	7.49	7.54	0.13	2.05	52.20	36.15	44.17	1.07	1.15	1.17	1.19	1.15
26000	7.53	7.59	7.57	7.64	0.11	2.08	33.08	36.56	32.87	1.16	1.12	1.14	1.14	1.09
26500	7.54	7.63	7.61	7.66	0.12	2.03	34.31	35.86	33.10	1.14	1.18	1.20	1.20	1.14
27000	7.53	7.63	7.59	7.64	0.11	2.05	42.61	35.53	41.33	1.09	1.17	1.18	1.18	1.13
27500	7.58	7.66	7.64	7.71	0.14	2.05	42.67	40.52	46.30	1.11	1.11	1.12	1.12	1.08
28000	7.58	7.67	7.64	7.71	0.13	2.20	33.99	43.55	35.64	1.16	1.05	1.06	1.08	1.04
28500	7.63	7.73	7.71	7.78	0.15	2.14	37.76	42.99	39.90	1.04	1.02	1.01	1.03	1.03
29000	7.66	7.76	7.73	7.81	0.15	2.20	34.28	40.64	33.84	1.19	1.14	1.12	1.12	1.16
29500	7.70	7.79	7.78	7.88	0.18	2.37	27.59	42.70	27.09	1.03	1.16	1.14	1.16	1.19
30000	7.75	7.84	7.85	7.96	0.20	2.30	25.99	39.45	25.32	1.12	1.12	1.11	1.11	1.15

<sup>1</sup>Total Loss = Insertion Loss + 6dB Splitter Loss



# 4 Way-0° Power Splitter/Combiner

# ZC4PD-06263-S+

## Typical Performance Data

TEST CONDITIONS: INPUT POWER = 0 dBm @Temperature = -55°C

FREQ. (MHz)	TOTAL LOSS <sup>1</sup> (dB)				AMP. UNBAL. (dB)	PHASE UNBAL. (deg.)	ISOLATION (dB)			VSWR (:1)				
	S-1	S-2	S-3	S-4			1-2	1-4	3-4	S	1	2	3	4
5000	6.41	6.44	6.46	6.46	0.05	0.97	15.32	23.03	15.44	1.13	1.22	1.21	1.26	1.25
6000	6.48	6.52	6.48	6.47	0.05	0.96	25.17	26.55	23.99	1.06	1.25	1.25	1.24	1.24
6500	6.46	6.51	6.54	6.50	0.07	0.80	21.34	29.49	20.15	1.04	1.05	1.04	1.04	1.04
7000	6.52	6.59	6.54	6.47	0.12	0.86	25.25	32.65	23.10	1.05	1.11	1.12	1.07	1.06
7500	6.57	6.63	6.63	6.56	0.07	1.21	26.89	37.49	26.13	1.06	1.08	1.09	1.08	1.07
8000	6.56	6.65	6.72	6.63	0.15	1.37	24.14	41.14	24.73	1.11	1.02	1.02	1.04	1.05
8500	6.63	6.66	6.68	6.65	0.06	1.20	23.06	41.53	24.40	1.19	1.15	1.15	1.13	1.13
9000	6.67	6.65	6.66	6.65	0.02	1.23	29.26	37.01	32.64	1.12	1.19	1.19	1.19	1.19
9500	6.67	6.65	6.66	6.68	0.03	1.22	30.14	34.13	27.36	1.05	1.14	1.12	1.15	1.17
10000	6.69	6.71	6.69	6.68	0.03	1.20	23.85	31.81	22.42	1.04	1.10	1.08	1.10	1.12
10500	6.68	6.78	6.78	6.73	0.10	1.25	25.81	30.52	23.88	1.08	1.11	1.09	1.14	1.15
11000	6.74	6.86	6.83	6.74	0.13	1.36	31.97	30.16	29.63	1.06	1.22	1.20	1.25	1.26
11500	6.80	6.91	6.89	6.80	0.11	1.41	31.74	31.26	35.77	1.29	1.19	1.19	1.21	1.21
12000	6.77	6.84	6.82	6.78	0.07	1.53	31.62	32.89	35.41	1.15	1.07	1.07	1.05	1.04
12500	6.82	6.85	6.86	6.85	0.04	1.66	42.92	37.23	32.63	1.22	1.22	1.19	1.19	1.19
13000	6.83	6.85	6.84	6.84	0.02	1.61	27.66	49.29	26.44	1.14	1.17	1.16	1.15	1.15
13500	6.84	6.88	6.83	6.82	0.06	1.54	25.02	40.78	25.02	1.18	1.11	1.11	1.14	1.11
14000	6.83	6.89	6.89	6.86	0.06	1.61	27.88	34.66	27.72	1.10	1.11	1.12	1.14	1.11
14500	6.91	6.99	6.97	6.94	0.08	1.71	32.75	31.76	31.24	1.25	1.02	1.03	1.02	1.01
15000	6.92	6.99	6.98	6.95	0.07	2.00	48.96	30.28	38.29	1.09	1.17	1.14	1.15	1.17
15500	6.99	7.03	7.04	7.05	0.05	1.89	29.72	30.95	28.80	1.39	1.27	1.25	1.28	1.30
16000	7.01	7.03	6.96	7.01	0.07	1.87	26.51	31.97	24.69	1.18	1.16	1.14	1.18	1.20
16500	7.07	7.09	7.09	7.12	0.05	1.97	26.96	36.41	25.40	1.41	1.36	1.34	1.35	1.35
17000	7.10	7.16	7.14	7.13	0.06	1.79	27.51	42.87	29.03	1.34	1.33	1.32	1.33	1.31
17500	7.04	7.12	7.11	7.06	0.08	2.11	31.00	43.25	37.24	1.16	1.26	1.23	1.23	1.23
18000	7.06	7.15	7.17	7.11	0.10	2.42	33.24	35.47	36.28	1.12	1.28	1.25	1.28	1.28
18500	7.11	7.20	7.20	7.15	0.10	2.46	34.45	34.02	34.87	1.21	1.24	1.23	1.28	1.26
19000	7.13	7.16	7.15	7.17	0.05	2.61	32.97	33.12	31.15	1.23	1.11	1.12	1.18	1.15
19500	7.16	7.17	7.16	7.19	0.03	2.48	26.72	34.66	26.16	1.21	1.07	1.09	1.13	1.09
20000	7.21	7.21	7.20	7.23	0.03	2.50	28.39	36.49	27.52	1.25	1.02	1.06	1.10	1.05
20500	7.18	7.20	7.18	7.18	0.03	2.60	45.29	41.99	39.20	1.16	1.12	1.08	1.05	1.09
21000	7.25	7.31	7.30	7.27	0.07	2.96	36.08	38.13	32.90	1.12	1.12	1.09	1.05	1.10
21500	7.31	7.41	7.41	7.32	0.10	3.06	35.74	34.91	32.52	1.19	1.22	1.19	1.13	1.17
22000	7.32	7.42	7.36	7.32	0.10	2.77	35.23	33.17	38.51	1.09	1.18	1.16	1.11	1.13
22500	7.33	7.40	7.39	7.38	0.06	2.73	38.84	32.61	43.00	1.18	1.19	1.15	1.12	1.15
23000	7.34	7.40	7.35	7.34	0.07	2.87	32.34	32.94	33.12	1.12	1.15	1.11	1.08	1.12
23500	7.34	7.40	7.36	7.36	0.06	3.06	32.26	36.13	35.45	1.16	1.14	1.12	1.10	1.13
24000	7.33	7.41	7.38	7.34	0.08	3.27	40.27	41.18	36.84	1.07	1.05	1.07	1.09	1.09
24500	7.36	7.49	7.41	7.36	0.13	3.32	27.42	61.02	27.10	1.08	1.03	1.02	1.04	1.03
25000	7.39	7.48	7.45	7.43	0.09	3.51	29.70	40.94	28.89	1.11	1.07	1.10	1.14	1.11
25500	7.36	7.40	7.38	7.41	0.04	3.16	47.62	36.41	50.40	1.05	1.11	1.12	1.15	1.12
26000	7.44	7.49	7.46	7.48	0.05	3.32	31.14	36.16	31.43	1.16	1.08	1.10	1.12	1.07
26500	7.47	7.52	7.48	7.49	0.05	2.90	34.65	34.62	33.16	1.12	1.15	1.16	1.18	1.14
27000	7.46	7.56	7.48	7.46	0.10	3.15	40.37	34.68	44.21	1.05	1.12	1.12	1.14	1.10
27500	7.49	7.59	7.54	7.52	0.10	3.29	37.66	39.04	42.73	1.11	1.07	1.08	1.09	1.06
28000	7.46	7.58	7.53	7.50	0.13	3.57	34.08	42.04	34.98	1.16	1.02	1.01	1.05	1.02
28500	7.54	7.63	7.56	7.56	0.09	3.55	38.20	42.58	40.28	1.08	1.06	1.05	1.02	1.05
29000	7.58	7.62	7.59	7.60	0.04	3.72	32.40	42.77	31.91	1.17	1.15	1.15	1.13	1.15
29500	7.67	7.66	7.64	7.69	0.05	3.71	26.32	43.87	25.97	1.04	1.14	1.12	1.13	1.15
30000	7.73	7.73	7.69	7.72	0.04	3.85	25.88	40.08	25.01	1.15	1.15	1.16	1.10	1.12

<sup>1</sup>Total Loss = Insertion Loss + 6dB Splitter Loss



# 4 Way-0° Power Splitter/Combiner

# ZC4PD-06263-S+

## Typical Performance Data

TEST CONDITIONS: INPUT POWER = 0 dBm @Temperature = +100°C

FREQ. (MHz)	TOTAL LOSS <sup>1</sup> (dB)				AMP. UNBAL. (dB)	PHASE UNBAL. (deg.)	ISOLATION (dB)			VSWR (:1)				
	S-1	S-2	S-3	S-4			1-2	1-4	3-4	S	1	2	3	4
5000	6.42	6.42	6.51	6.57	0.16	0.77	15.05	23.13	15.25	1.14	1.22	1.22	1.25	1.25
6000	6.49	6.49	6.55	6.60	0.11	1.14	26.16	26.33	24.42	1.06	1.26	1.25	1.24	1.25
6500	6.49	6.48	6.58	6.63	0.15	1.35	21.49	29.40	20.11	1.05	1.05	1.04	1.06	1.07
7000	6.54	6.53	6.56	6.60	0.07	1.34	24.69	33.05	22.65	1.04	1.09	1.10	1.05	1.05
7500	6.56	6.55	6.61	6.65	0.10	1.09	26.41	39.35	25.43	1.09	1.06	1.06	1.07	1.06
8000	6.60	6.59	6.67	6.71	0.12	1.25	24.16	44.09	24.70	1.13	1.03	1.03	1.06	1.06
8500	6.65	6.63	6.67	6.71	0.08	1.53	22.96	39.44	24.08	1.16	1.12	1.13	1.13	1.13
9000	6.66	6.64	6.66	6.70	0.06	1.17	27.74	35.12	30.00	1.10	1.18	1.19	1.18	1.18
9500	6.67	6.64	6.69	6.73	0.09	1.27	33.05	32.59	28.43	1.04	1.17	1.15	1.18	1.19
10000	6.71	6.69	6.71	6.76	0.07	1.18	24.30	30.96	22.46	1.05	1.14	1.12	1.15	1.17
10500	6.73	6.71	6.77	6.80	0.10	1.43	24.65	30.36	22.96	1.09	1.11	1.09	1.15	1.16
11000	6.77	6.76	6.77	6.80	0.04	1.48	29.11	30.25	27.79	1.05	1.22	1.22	1.27	1.26
11500	6.86	6.84	6.85	6.88	0.03	1.41	30.09	31.54	34.36	1.29	1.20	1.21	1.23	1.21
12000	6.83	6.82	6.82	6.84	0.03	1.29	31.33	33.34	36.51	1.15	1.07	1.07	1.05	1.03
12500	6.88	6.86	6.88	6.90	0.04	1.34	46.46	37.85	33.19	1.23	1.22	1.21	1.21	1.20
13000	6.88	6.86	6.85	6.88	0.03	1.47	27.69	46.60	26.43	1.15	1.18	1.18	1.18	1.17
13500	6.92	6.91	6.86	6.88	0.06	1.26	25.00	39.11	24.80	1.19	1.12	1.12	1.15	1.13
14000	6.91	6.90	6.90	6.92	0.02	1.25	27.21	33.72	26.83	1.11	1.11	1.13	1.15	1.12
14500	6.99	6.97	6.96	6.98	0.03	1.28	29.87	31.28	28.91	1.28	1.05	1.05	1.06	1.03
15000	6.97	6.95	6.94	6.96	0.04	1.32	41.26	30.00	36.70	1.11	1.17	1.14	1.14	1.17
15500	7.10	7.07	7.07	7.08	0.03	1.44	30.78	30.66	29.91	1.40	1.31	1.29	1.32	1.33
16000	7.09	7.06	7.01	7.03	0.08	1.44	26.29	31.61	24.52	1.25	1.18	1.17	1.21	1.21
16500	7.13	7.10	7.12	7.13	0.03	1.53	26.21	35.84	24.57	1.36	1.34	1.33	1.34	1.34
17000	7.23	7.20	7.19	7.20	0.03	1.54	27.20	43.03	27.92	1.41	1.36	1.36	1.37	1.34
17500	7.14	7.10	7.08	7.09	0.05	1.60	30.05	46.18	35.34	1.13	1.26	1.24	1.24	1.23
18000	7.14	7.12	7.12	7.13	0.03	1.73	32.87	35.96	35.62	1.17	1.29	1.27	1.29	1.28
18500	7.18	7.15	7.16	7.16	0.03	1.75	32.82	34.09	34.21	1.17	1.25	1.24	1.29	1.26
19000	7.21	7.19	7.19	7.18	0.03	1.81	35.89	32.42	32.97	1.25	1.15	1.17	1.22	1.18
19500	7.20	7.20	7.17	7.17	0.03	1.90	26.97	33.30	26.07	1.16	1.05	1.07	1.11	1.07
20000	7.29	7.27	7.23	7.24	0.06	1.79	26.96	35.54	26.03	1.25	1.05	1.09	1.12	1.06
20500	7.29	7.25	7.23	7.24	0.06	1.92	36.17	40.83	33.96	1.19	1.09	1.07	1.06	1.09
21000	7.30	7.28	7.25	7.26	0.05	2.18	37.20	38.80	33.39	1.09	1.11	1.07	1.05	1.10
21500	7.34	7.34	7.32	7.30	0.04	2.29	35.79	35.23	31.74	1.16	1.19	1.16	1.11	1.15
22000	7.45	7.49	7.41	7.37	0.11	1.59	36.66	34.19	36.37	1.10	1.19	1.17	1.11	1.14
22500	7.42	7.42	7.41	7.39	0.03	2.03	36.73	33.67	41.05	1.14	1.17	1.15	1.10	1.13
23000	7.42	7.42	7.38	7.36	0.06	2.36	31.82	33.29	33.07	1.11	1.13	1.09	1.07	1.11
23500	7.42	7.42	7.37	7.36	0.07	2.30	31.31	36.20	34.15	1.12	1.12	1.09	1.08	1.11
24000	7.45	7.42	7.40	7.40	0.05	2.48	41.49	43.80	38.58	1.06	1.05	1.06	1.09	1.08
24500	7.43	7.44	7.37	7.33	0.10	2.50	28.87	57.17	27.72	1.05	1.04	1.03	1.06	1.05
25000	7.46	7.46	7.45	7.42	0.04	2.45	29.70	40.29	28.22	1.14	1.08	1.10	1.14	1.10
25500	7.45	7.44	7.43	7.40	0.05	2.44	47.08	36.12	41.06	1.05	1.15	1.17	1.20	1.17
26000	7.56	7.54	7.50	7.49	0.07	2.45	34.17	36.44	33.68	1.15	1.13	1.15	1.16	1.11
26500	7.58	7.57	7.54	7.50	0.08	2.48	34.34	36.01	33.35	1.14	1.18	1.20	1.22	1.16
27000	7.56	7.57	7.53	7.48	0.09	2.54	40.94	35.66	40.88	1.11	1.18	1.19	1.20	1.16
27500	7.61	7.61	7.58	7.54	0.07	2.55	43.14	41.75	46.37	1.12	1.12	1.12	1.14	1.10
28000	7.61	7.62	7.57	7.52	0.09	2.72	33.72	44.67	35.08	1.16	1.06	1.06	1.10	1.05
28500	7.67	7.68	7.64	7.58	0.10	2.65	37.02	44.77	38.79	1.04	1.02	1.02	1.05	1.01
29000	7.71	7.71	7.67	7.62	0.10	2.78	34.80	40.68	33.86	1.21	1.14	1.14	1.13	1.13
29500	7.74	7.74	7.72	7.67	0.07	2.88	27.49	42.54	26.90	1.06	1.16	1.15	1.18	1.17
30000	7.79	7.79	7.76	7.71	0.09	2.87	26.24	39.36	25.38	1.12	1.13	1.13	1.12	1.12

<sup>1</sup>Total Loss = Insertion Loss + 6dB Splitter Loss



# 4 Way-0° Power Splitter/Combiner

# ZC4PD-06263-S+

## Typical Performance Curves

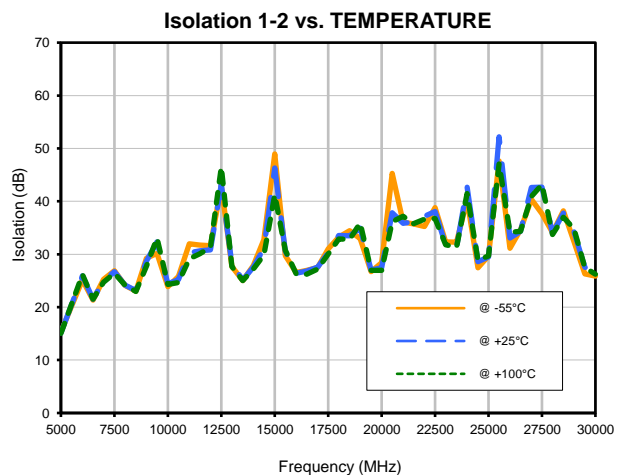
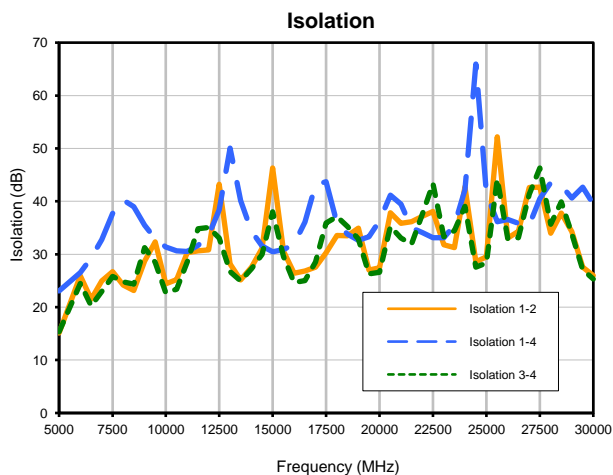
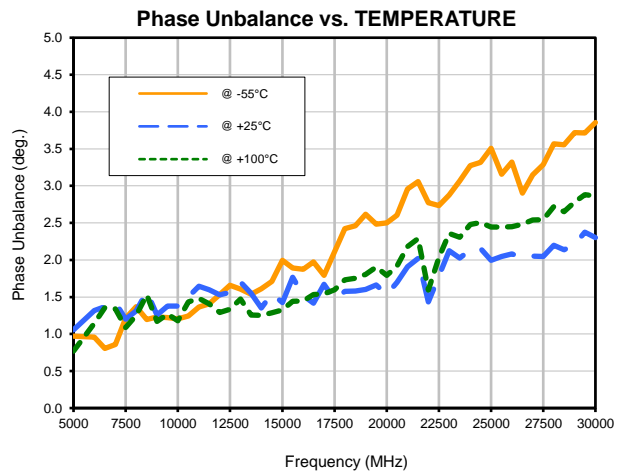
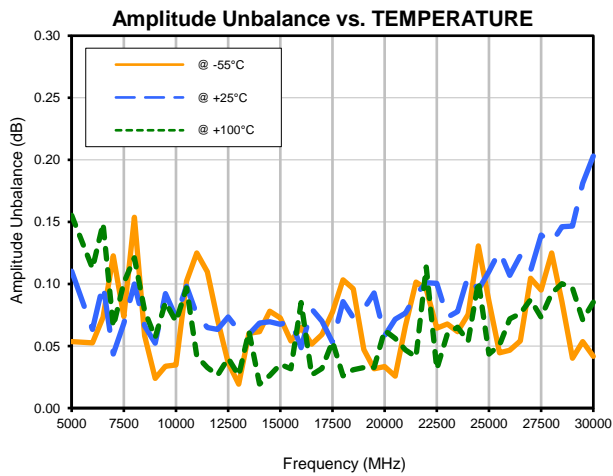
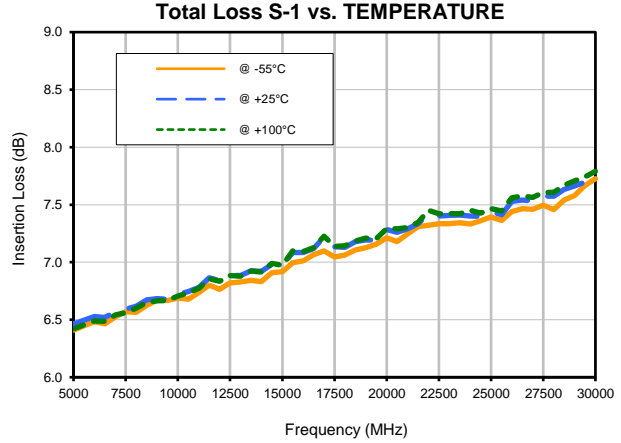
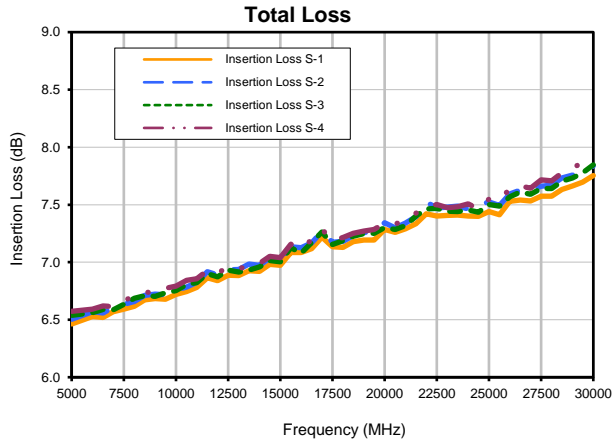

## Typical Performance Curves

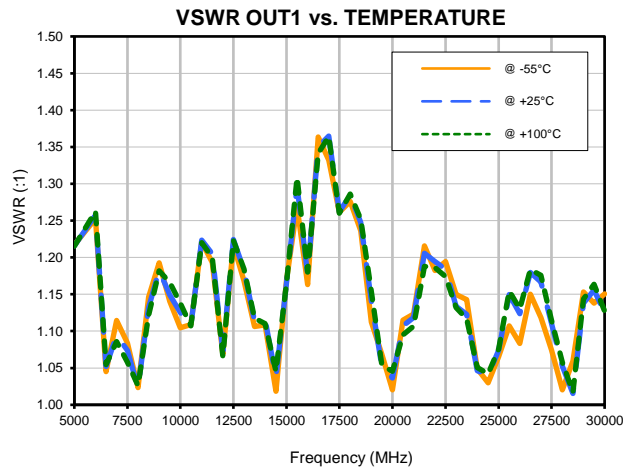
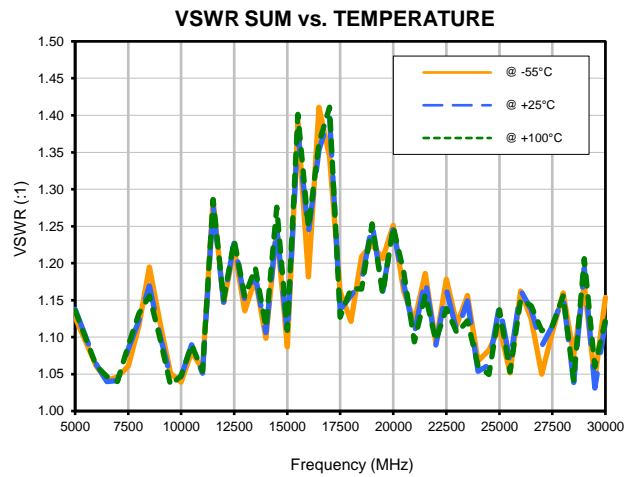
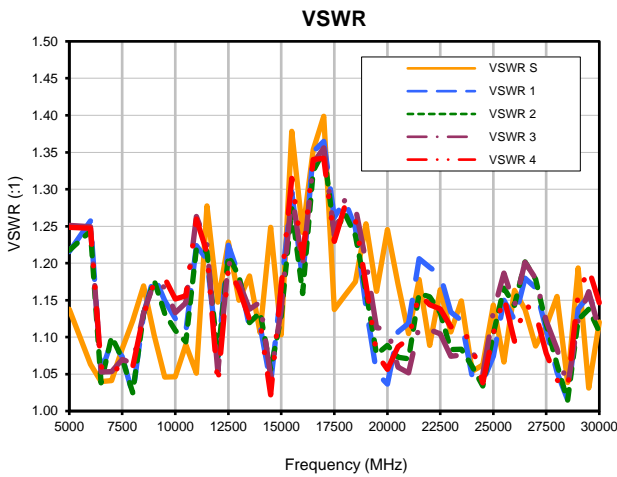

# Case Style

# UU

## Outline Dimensions

## UU2413-3

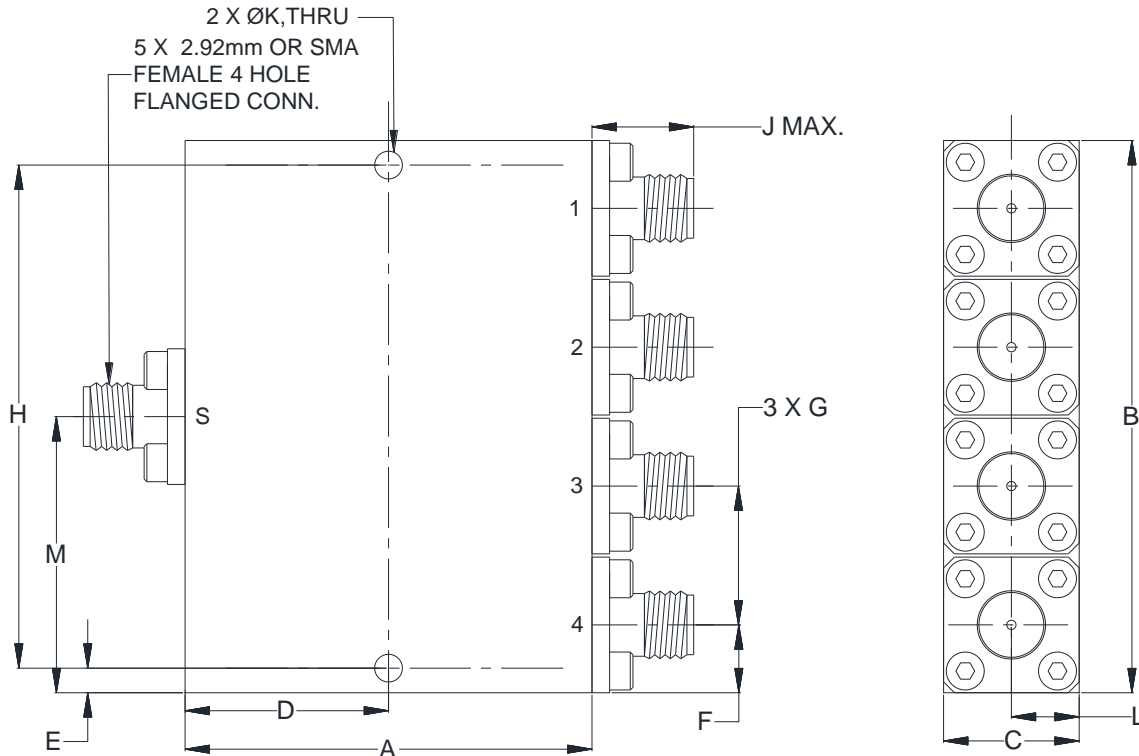

CASE#	A	B	C	D	E	F	G	H	J	K	L	M
UU2413-3	1.50 (38.10)	2.04 (51.70)	.50 (12.70)	.750 (19.05)	0.091 (2.30)	.25 (6.35)	.51 (13.0)	1.854 (47.10)	.43 (11.0)	.100 (2.60)	.25 (6.35)	1.02 (25.85)

CASE#	WT. GRAMS
UU2413-3	110

Dimensions are in inches (mm). Tolerances: 2 Pl.  $\pm$  .03; 3 Pl.  $\pm$  .015

### Notes:

1. Case material: Aluminum alloy.
2. Case finish: Painting Color: Blue.
3. Refer to the individual model data sheet for the type of connectors available.

**Mini-Circuits®**  
ISO 9001 ISO 14001 CERTIFIED

ALL NEW  
minicircuits.com

P.O. Box 350166, Brooklyn, New York 11235-0003 (718) 934-4500 Fax (718) 332-4661 For detailed performance specs & shopping online see Mini-Circuits web site



The Design Engineers Search Engine Provides ACTUAL Data Instantly From MINI-CIRCUITS At: [www.minicircuits.com](http://www.minicircuits.com)

RF/IF MICROWAVE COMPONENTS





All Mini-Circuits products are manufactured under exacting quality assurance and control standards, and are capable of meeting published specifications after being subjected to any or all of the following physical and environmental test.

Specification	Test/Inspection Condition	Reference/Spec
Operating Temperature	-55° to 100°C Ambient Environment	Individual Model Data Sheet
Storage Temperature	-55° to 100° C Ambient Environment	Individual Model Data Sheet
Thermal Shock	-55° to 100°C, 25 cycles	MIL-STD-202, Method 107, Condition A-1 except +100°C instead of 85°C
Vibration (High Frequency)	20g peak, 10-2000 Hz, 12 times in each of three perpendicular directions (total 36)	MIL-STD-202, Method 204, Condition D
Mechanical Shock	100g, 6ms sawtooth, 3 shocks each direction 3 axes (total 18)	MIL-STD-202, Method 213, Condition I
Connector Durability	500 mating/unmating cycles	MIL-PRF-39012E, PARAGRAPH 4.6.12