

DC Pass High Power Splitter Combiner

ZB4PD-332HP+

4 Way-0° 50Ω Up to 100W 500 to 3300 MHz

The Big Deal

- High power, up to 100W as a splitter
- Low insertion loss, 0.8 dB
- Good isolation, 22 dB



ZB4PD-332HPX-N+



ZB4PD-332HP-N+

Product Overview

Mini-Circuits' ZB4PD-332HP+ is a 4-way 0° splitter combiner providing very high power handling and low insertion loss across 500 to 3300 MHz, covering many wireless communications bands as well as satellite IF. Its outstanding combination of high power and low loss minimize power dissipation due to intrinsic losses and provide excellent signal fidelity from input to output. This model also provides high port-to-port isolation and very low amplitude and phase unbalance. It comes housed in a rugged aluminum alloy case with your choice of SMA or N-Type connectors and an optional heat sink for cooling.

Key Features

Feature	Advantages
Wideband, 500 to 3300 MHz	ZB4PD-332HP+ covers many popular wireless communications bands, making it suitable for a wide variety of applications.
High power handling: <ul style="list-style-type: none">• 100W as a splitter• 10W as a combiner	Suitable for many high power applications.
Low insertion loss, 0.8 dB	Very low insertion loss minimizes intrinsic losses, making this model a suitable candidate for high power signal distribution applications where low loss is a requirement.
Low unbalance: <ul style="list-style-type: none">• 0.2 dB amplitude unbalance• 3° phase unbalance	ZB4PD-332HP+ produces nearly equal output signals, ideal for parallel path / multichannel systems.
DC Passing, 0.5A (each port)	Supports applications where DC power is needed at later stages in the system.

Notes

- A. Performance and quality attributes and conditions not expressly stated in this specification document are intended to be excluded and do not form a part of this specification document.
B. Electrical specifications and performance data contained in this specification document are based on Mini-Circuit's applicable established test performance criteria and measurement instructions.
C. The parts covered by this specification document are subject to Mini-Circuits standard limited warranty and terms and conditions (collectively, "Standard Terms"); Purchasers of this part are entitled to the rights and benefits contained therein. For a full statement of the Standard Terms and the exclusive rights and remedies thereunder, please visit Mini-Circuits' website at www.minicircuits.com/MCLStore/terms.jsp



DC Pass

High Power Splitter Combiner

4 Way-0° 50Ω Up to 100W 500 to 3300 MHz

ZB4PD-332HP+



CASE STYLE: BV278-2

Connectors	Model
SMA	ZB4PD-332HP-S+
SMA	ZB4PD-332HPX-S+ [▲]
N-TYPE	ZB4PD-332HP-N+
N-TYPE	ZB4PD-332HPX-N+ [▲]

+RoHS Compliant
The +Suffix identifies RoHS Compliance. See our web site for RoHS Compliance methodologies and qualifications

Maximum Ratings

Operating Temperature	0°C to 50°C
Storage Temperature	-55°C to 100°C
Power Input (as a splitter)	100W max.
Internal Dissipation	45W max.
DC Current (each port)	0.5A max.
Permanent damage may occur if any of these limits are exceeded.	

Coaxial Connections

SUM PORT	S
PORT 1	1
PORT 2	2
PORT 3	3
PORT 4	4

Outline Drawing

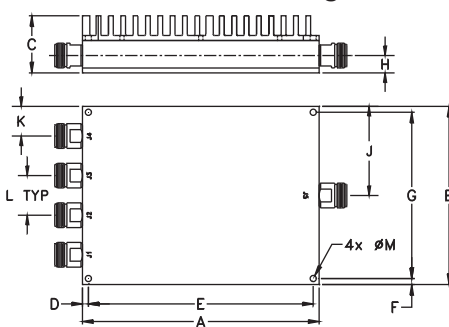

Outline Dimensions (inch/mm)

A	B	C	D	E	F	G
6.00	4.50	1.45	.15	5.700	.15	4.200
152.40	114.30	36.83	3.81	144.78	3.81	106.68
H	J	K	L	M	N	wt
.44	2.25	.75	1	.156	0.82	grams
11.18	57.15	19.05	25.40	3.96	20.83	1100

Electrical Schematic

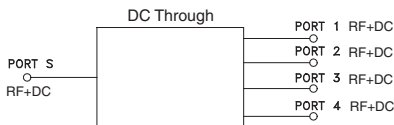

Features

- usable, 500 to 3300 MHz
- low insertion loss, 0.8 dB typ.
- low amplitude unbalance, 0.15 dB typ.
- excellent output VSWR, 1.15:1 typ.
- DC Pass from sum port to all output ports

Applications

- high band PCS
- UNII
- WIMAX
- WiFi
- bluetooth

Electrical Specifications at 25°C

Parameter	Frequency (MHz)	Min.	Typ.	Max.	Unit	
Frequency Range		500		3300	MHz	
Insertion Loss Above 6.0 dB	700-2700 500-3300	—	0.7 1.0	1.2 1.6	dB	
Isolation	700-2700 500-3300	19 13	25 22	—	dB	
Phase Unbalance	700-2700 500-3300	—	2.0 3.0	8.0 10.0	Degree	
Amplitude Unbalance	700-2700 500-3300	—	0.15 0.2	0.5 0.6	dB	
VSWR (Port S)	700-2700 500-3300	—	1.25 1.35	1.50 1.75	:1	
VSWR (Port 1-4)	700-2700 500-3300	—	1.15 1.25	1.25 1.55	:1	
Power Input¹	as splitter²	500-2700 2700-3300	— —	— —	100 50	W
	as combiner¹	500-2700 2700-3300	— —	— —	10 8	

1. As a combiner of non-coherent signals, max. power per port is power rating divided by four ports.
2. All outputs must be terminated with loads (VSWR>2:1).

[▲] Heat sink and fan not included. Alternative heat sinking and heat removal must be provided by the user to limit maximum base-plate temperature to 60°C, in order to ensure proper performance. For reference, this requires thermal resistance of user's external heat sink to be 1.2°C/W max.

Typical Performance Data

Freq. (MHz)	Total Loss ¹ (dB)				Amp. Unb. (dB)	Isolation (dB)			Phase Unb. (deg.)	VSWR S	VSWR 1	VSWR 2	VSWR 3	VSWR 4
	S-1	S-2	S-3	S-4		1-2	2-3	3-4						
500	6.31	6.32	6.28	6.28	0.04	18.21	22.40	18.34	0.34	1.23	1.10	1.10	1.10	1.10
700	6.32	6.34	6.31	6.32	0.04	29.39	34.76	30.57	0.38	1.14	1.02	1.03	1.03	1.04
900	6.40	6.45	6.40	6.38	0.07	26.67	31.14	25.90	0.47	1.22	1.04	1.05	1.05	1.06
1100	6.43	6.49	6.44	6.42	0.07	25.09	26.48	24.49	0.54	1.20	1.05	1.07	1.05	1.05
1300	6.50	6.57	6.51	6.48	0.09	23.61	27.17	23.37	0.56	1.25	1.08	1.09	1.07	1.08
1500	6.54	6.61	6.55	6.52	0.09	24.96	33.19	25.05	0.70	1.25	1.03	1.04	1.03	1.04
1700	6.56	6.63	6.56	6.53	0.11	35.77	37.42	34.12	0.80	1.15	1.08	1.09	1.08	1.10
1900	6.61	6.67	6.60	6.57	0.09	27.38	30.28	26.53	0.76	1.20	1.01	1.01	1.00	1.03
2100	6.64	6.71	6.61	6.59	0.12	23.67	28.69	23.16	0.81	1.11	1.02	1.04	1.02	1.04
2300	6.72	6.81	6.71	6.69	0.15	22.88	31.89	23.05	1.06	1.23	1.07	1.07	1.09	1.10
2500	6.74	6.84	6.75	6.68	0.16	34.66	43.86	35.28	1.11	1.06	1.11	1.09	1.12	1.15
2700	6.82	6.94	6.84	6.76	0.18	26.89	34.54	25.54	1.21	1.19	1.02	1.03	1.02	1.03
2900	6.90	7.02	6.90	6.81	0.21	25.95	29.54	26.14	1.35	1.14	1.08	1.08	1.09	1.11
3100	7.00	7.12	6.98	6.87	0.24	19.92	27.68	20.29	1.55	1.09	1.16	1.19	1.18	1.19
3300	7.16	7.23	7.14	7.05	0.18	18.51	23.41	17.88	2.15	1.26	1.32	1.32	1.31	1.35

1. Total Loss = Insertion Loss + 6dB splitter loss.

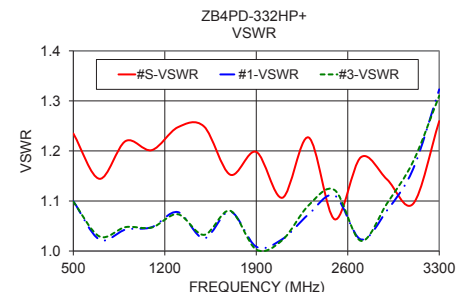
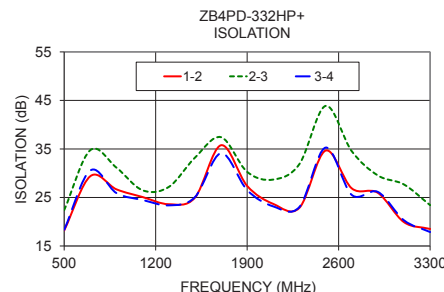
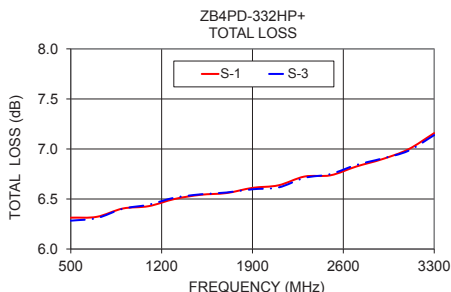

Notes

- Performance and quality attributes and conditions not expressly stated in this specification document are intended to be excluded and do not form a part of this specification document.
- Electrical specifications and performance data contained in this specification document are based on Mini-Circuit's applicable established test performance criteria and measurement instructions.
- The parts covered by this specification document are subject to Mini-Circuit's standard limited warranty and terms and conditions (collectively, "Standard Terms"); Purchasers of this part are entitled to the rights and benefits contained therein. For a full statement of the Standard Terms and the exclusive rights and remedies thereunder, please visit Mini-Circuit's website at www.minicircuits.com/WCLStore/terms.jsp



www.minicircuits.com P.O. Box 350166, Brooklyn, NY 11235-0003 (718) 934-4500 sales@minicircuits.com

REV. B
M170684
ED-16142/2
ZN4PD-332HP+
WP/CP/AM
181024
Page 2 of 2

4 Way-0° Power Splitter/Combiner

ZB4PD-332HP+

Typical Performance Data

Table with columns: FREQ. (MHz), TOTAL LOSS¹ (dB) S1, S2, S3, S4, AMP UNBAL. (dB), ISOLATION (dB) 1-2, 2-3, 3-4, PHASE UNBAL. (Deg), FREQ. (MHz), VSWR (S, 1, 2, 3, 4).

¹Total Loss = Insertion Loss + 6dB Splitter Loss



Typical Performance Curves

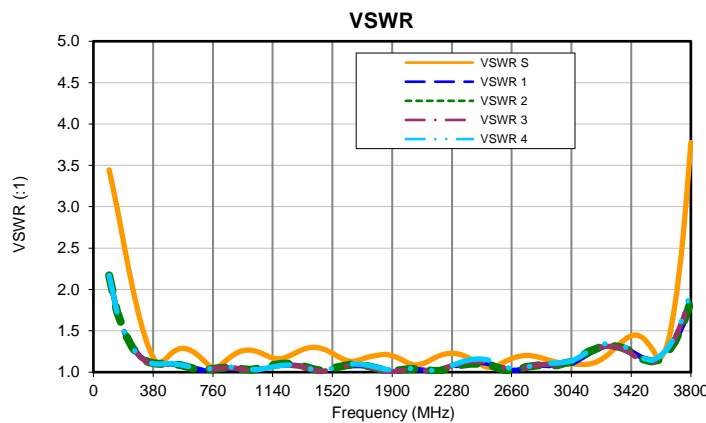
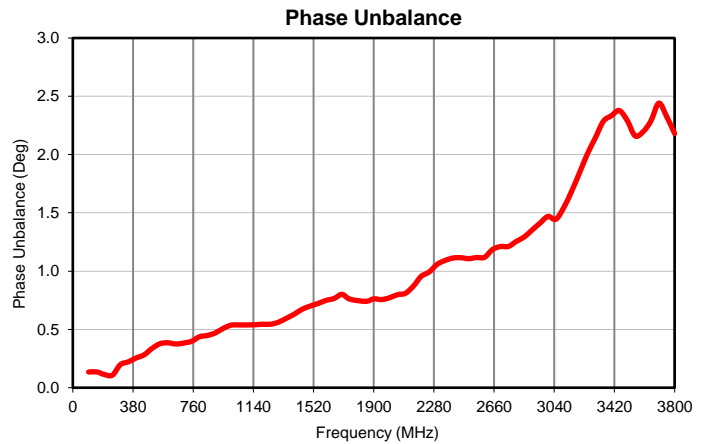
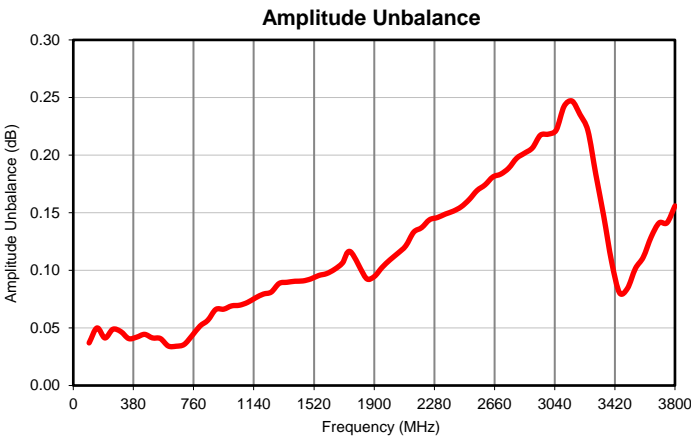
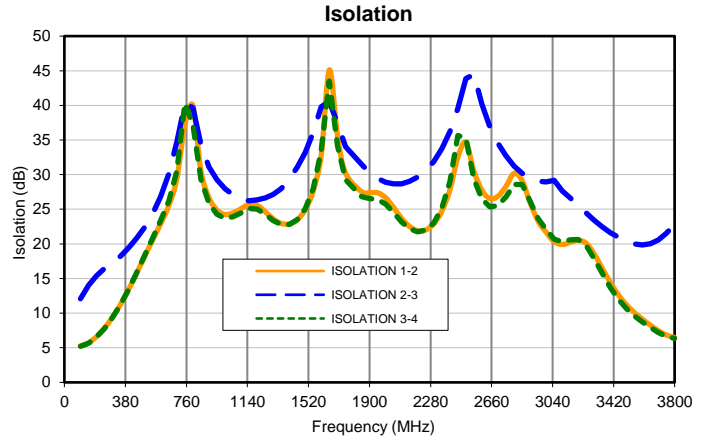
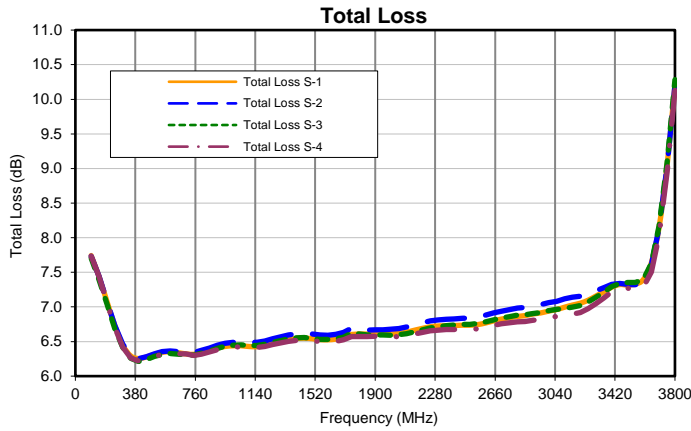

Outline Dimensions

BV278-2

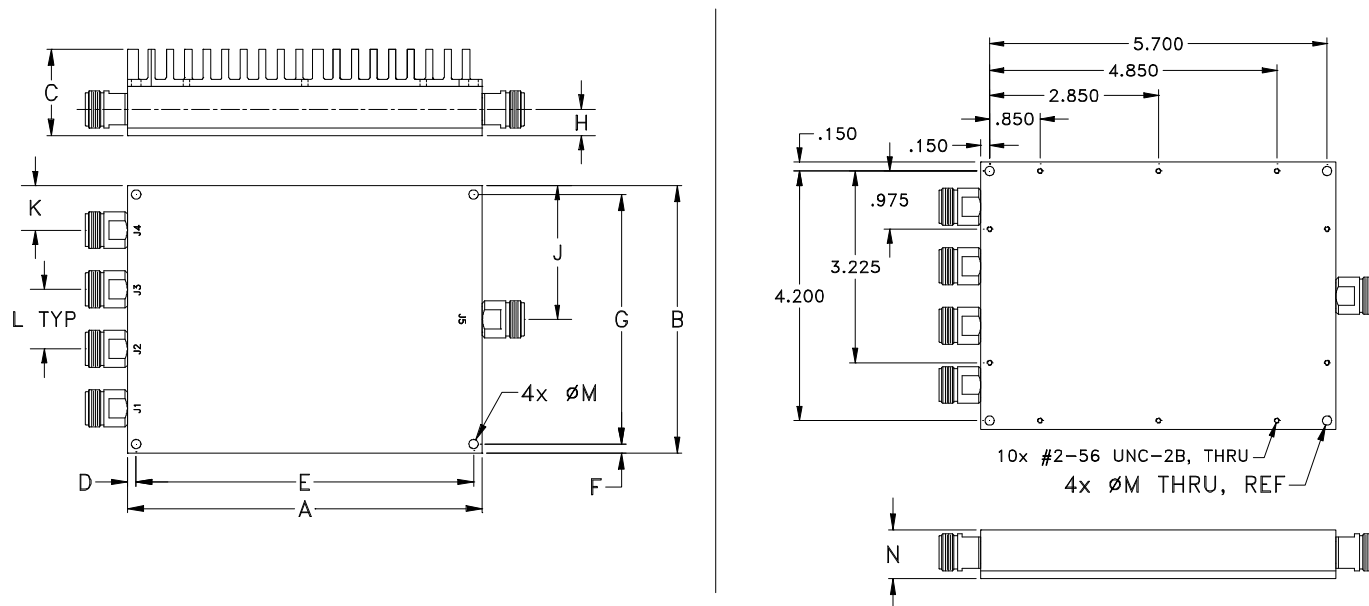

MOUNTING INFORMATION FOR MODELS WITHOUT HEATSINK

CASE #	A	B	C	D	E	F	G	H	J	K
BV278-2	6.00 (152.40)	4.50 (114.30)	1.45 (36.83)	.15 (3.81)	5.700 (144.78)	.15 (3.81)	4.200 (106.68)	.44 (11.18)	2.25 (57.15)	.75 (19.05)

CASE #	L	M	N	WT. GRAMS	WT. GRAMS WITHOUT HEATSINK
BV278-2	1.00 (25.40)	.156 (3.96)	.82 (20.83)	1100	800

Dimensions are in inches (mm). Tolerances: 2 Pl. $\pm .03$; 3Pl. $\pm .015$

Notes:

- Case material: Aluminum alloy.
- Case finish:
For RoHS Case Styles: Clear chemical conversion coating, non-chrome or trivalent chrome based.
- Heat sink finish: Black Anodize.



INTERNET <http://www.minicircuits.com>

P.O. Box 350166, Brooklyn, New York 11235-0003 (718) 934-4500 Fax (718) 332-4661

Distribution Centers NORTH AMERICA 800-654-7949 • 417-335-5935 • Fax 417-335-5945 • EUROPE 44-1252-832600 • Fax 44-1252-837010

Mini-Circuits ISO 9001 & ISO 14001 Certified



All Mini-Circuits products are manufactured under exacting quality assurance and control standards, and are capable of meeting published specifications after being subjected to any or all of the following physical and environmental test.

Specification	Test/Inspection Condition	Reference/Spec
Operating Temperature	-0° to 50° C Ambient Environment	Individual Model Data Sheet
Storage Temperature	-40° to 100° C Ambient Environment	Individual Model Data Sheet
Barometric Pressure	100,000 Feet	MIL-STD-202, Method 105, Condition D
Humidity	90% RH, 65°C Units may require bake-out after humidity to restore full performance.	MIL-STD-202, Method 103
Thermal Shock	-65° to 125°C, 5 cycles	MIL-STD-202, Method 107, Condition B
Vibration (High Frequency)	20g peak, 10-2000 Hz, 12 times in each of three perpendicular directions (total 36)	MIL-STD-202, Method 204, Condition D
Mechanical Shock	100g, 6ms sawtooth, 3 shocks each direction 3 axes (total 18)	MIL-STD-202, Method 213, Condition I