

High Power, DC Pass

Power Splitter/Combiner

ZB2PD-63+

2 Way-0° 50Ω 30W 600 to 6000 MHz

The Big Deal

- Wideband, 600 to 6000 MHz
- High power, up to 30W as a splitter
- Low insertion loss, 0.8 dB
- Low unbalance, 0.15 dB, 2°
- High isolation, 19 dB



(N-Type Shown)

CASE STYLE: JJJ1457

Product Overview

Mini-Circuits' ZB2PD-63+ is a 2-way 0° high-power splitter/combiner providing up to 30W power handling as a splitter (1.0W as a combiner) and low insertion loss across the entire 600 to 6000 MHz frequency range. Its outstanding combination of high power handling and low loss minimize power dissipation and provide excellent signal power transmission from input to output. The ZB2PD-63+ comes housed in a rugged aluminum alloy case measuring 1.99 x 5.26 x 0.95" with your choice of SMA or N-type connectors.

Key Features

Feature	Advantages
Wideband, 600 to 6000 MHz	This model supports bandwidth requirements for a wide variety of applications.
High power handling: <ul style="list-style-type: none">• 30W to 3600 MHz• 20W to 6000 MHz	The ZB2PD-63+ is suitable for systems with a wide range of power requirements.
Low insertion loss, 0.8 dB	The combination of 30W power handling and low insertion loss makes this model a suitable candidate for distributing signals while maintaining excellent transmission of signal power.
Low unbalance: <ul style="list-style-type: none">• 0.15 dB amplitude unbalance• 2° phase unbalance	Produces nearly equal output signals, ideal for parallel path and multichannel systems.
High isolation, 19 dB	Minimizes interference between ports.
DC Passing, 400mA (200mA each port)	Supports applications where DC power is needed through the RF line.

Notes

- A. Performance and quality attributes and conditions not expressly stated in this specification document are intended to be excluded and do not form a part of this specification document.
B. Electrical specifications and performance data contained in this specification document are based on Mini-Circuit's applicable established test performance criteria and measurement instructions.
C. The parts covered by this specification document are subject to Mini-Circuits standard limited warranty and terms and conditions (collectively, "Standard Terms"); Purchasers of this part are entitled to the rights and benefits contained therein. For a full statement of the Standard Terms and the exclusive rights and remedies thereunder, please visit Mini-Circuits' website at www.minicircuits.com/MCLStore/terms.jsp



High Power, DC Pass

Power Splitter/Combiner

ZB2PD-63+

2 Way-0° 50Ω 30W 600 to 6000 MHz

Maximum Ratings

Operating Temperature(@<30W)	-55°C to 60°C
Operating Temperature(@<10W)	-55°C to 100°C
Storage Temperature	-55°C to 100°C
DC Current	400 mA (200mA for each port)

Permanent damage may occur if any of these limits are exceeded.

Coaxial Connections

SUM PORT	S
PORT 1	1
PORT 2	2

Outline Drawing

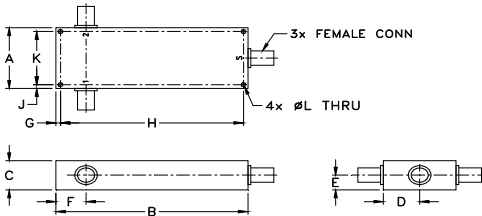

Outline Dimensions (inch/mm)

A	B	C	D	E	F
1.99	5.26	.95	1.00	.51	.83
50.55	133.60	24.13	25.40	12.95	21.08
G	H	J	K	L	wt
.13	5.010	.13	1.740	.125	grams
3.30	127.25	3.30	44.20	3.18	350.0

Features

- low insertion loss, 0.8 dB typ.
- wideband, 600 to 6000 MHz
- excellent amplitude unbalance, 0.15 dB typ.
- excellent phase unbalance, 2 deg. typ.
- up to 30W power input as splitter
- rugged shielded case

Applications

- UHF TV
- cellular/ISM/SMG/GSM
- satellite distribution
- GPS/L BAND (MARSAT)
- PCS/DCS/UMTS
- MMDC
- SATCOM
- Instrumentation



Generic photo used for illustration purposes only
(N-Type Shown)

CASE STYLE: JJJ1457

Connectors	Model
N-Type	ZB2PD-63-N+
SMA	ZB2PD-63-S+

+RoHS Compliant

The +Suffix identifies RoHS Compliance. See our web site for RoHS Compliance methodologies and qualifications

Electrical Specifications at 25°C

Parameter	Frequency (MHz)	Min.	Typ.	Max.	Unit
Frequency		600		6000	MHz
Insertion Loss (above theoretical 3.0 dB)	600-1600	—	0.3	0.5	dB
	1600-2700	—	0.4	0.6	
	2700-3600	—	0.5	0.8	
	3600-6000	—	0.9	1.2	
Isolation	600-1600	16	19	—	dB
	1600-2700	16	19	—	
	2700-3600	17	21	—	
	3600-6000	12	15	—	
Phase Unbalance	600-1600	—	1.5	4	Degree
	1600-2700	—	2.4	5	
	2700-3600	—	2.6	7	
	3600-6000	—	4.6	9	
Amplitude Unbalance	600-1600	—	0.1	0.2	dB
	1600-2700	—	0.1	0.2	
	2700-3600	—	0.1	0.3	
	3600-6000	—	0.2	0.4	
VSWR (Port S)	600-1600	—	1.33	—	:1
	1600-2700	—	1.38	—	
	2700-3600	—	1.48	—	
	3600-6000	—	1.72	—	
VSWR (Port 1-2)	600-1600	—	1.23	—	:1
	1600-2700	—	1.26	—	
	2700-3600	—	1.48	—	
	3600-6000	—	1.53	—	
Power Handling³	As Splitter¹	600-3600	—	30	W
		3600-6000	—	20	
	As Combiner²	600-3600	—	1.0	

1. All outputs must terminate 50 ohm (VSWR 1.5:1 or better)
2. As a combiner of non-coherent signals, max. power per port is 1.0 watt power rating divided by number of ports.
3. Alternative heat sinking and heat removal must be provided by the user to limit maximum base-plate temperature to 60°C, in order to ensure proper performance. For reference, this requires thermal resistance of user's external heat sink to be 10°C/W.

Electrical Schematic

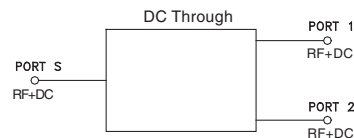

Notes

- A. Performance and quality attributes and conditions not expressly stated in this specification document are intended to be excluded and do not form a part of this specification document.
- B. Electrical specifications and performance data contained in this specification document are based on Mini-Circuit's applicable established test performance criteria and measurement instructions.
- C. The parts covered by this specification document are subject to Mini-Circuits standard limited warranty and terms and conditions (collectively, "Standard Terms"); Purchasers of this part are entitled to the rights and benefits contained therein. For a full statement of the Standard Terms and the exclusive rights and remedies thereunder, please visit Mini-Circuits' website at www.minicircuits.com/MCLStore/terms.jsp



Typical Performance Data

Frequency (MHz)	Total Loss ¹ (dB)		Amplitude Unbalance (dB)	Isolation (dB)	Phase Unbalance (deg.)	VSWR S	VSWR 1	VSWR 2
	S-1	S-2						
600.00	3.11	3.12	0.01	26.85	0.12	1.13	1.07	1.12
700.00	3.13	3.13	0.01	21.82	0.14	1.07	1.09	1.07
1200.00	3.17	3.18	0.01	23.85	0.26	1.12	1.07	1.11
1600.00	3.23	3.24	0.01	26.05	0.37	1.14	1.21	1.13
1800.00	3.22	3.23	0.01	29.26	0.43	1.09	1.12	1.08
2700.00	3.32	3.30	0.02	22.99	0.77	1.15	1.19	1.17
3000.00	3.35	3.32	0.03	36.64	0.74	1.21	1.23	1.26
3600.00	3.36	3.35	0.02	26.45	0.71	1.15	1.09	1.16
3700.00	3.37	3.36	0.01	25.29	0.70	1.12	1.03	1.13
3800.00	3.36	3.37	0.00	25.45	0.72	1.11	1.02	1.12
5000.00	3.69	3.66	0.02	32.45	1.33	1.35	1.37	1.35
5800.00	3.74	3.63	0.10	19.25	1.82	1.35	1.43	1.34
6000.00	3.68	3.53	0.15	16.13	1.64	1.45	1.33	1.45

1. Total Loss = Insertion Loss + 3dB splitter loss.

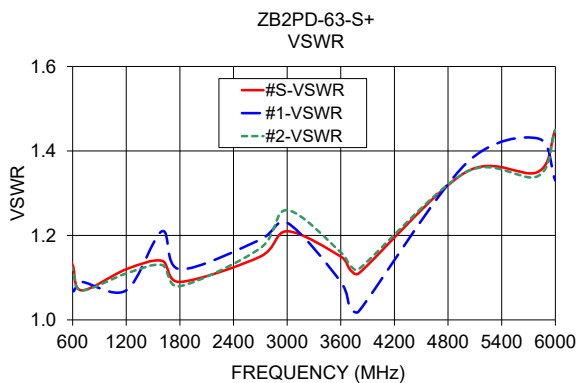
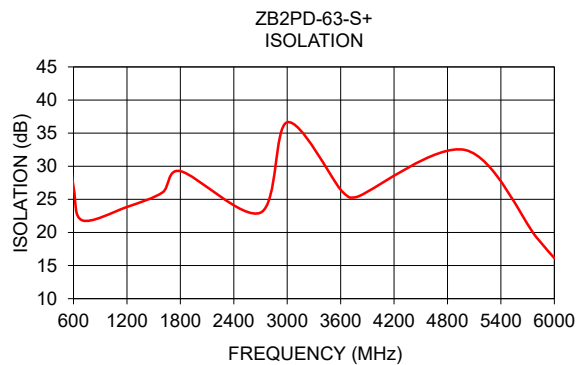
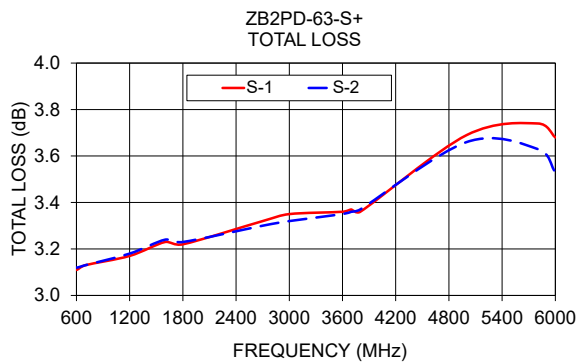

Notes

- A. Performance and quality attributes and conditions not expressly stated in this specification document are intended to be excluded and do not form a part of this specification document.
- B. Electrical specifications and performance data contained in this specification document are based on Mini-Circuit's applicable established test performance criteria and measurement instructions.
- C. The parts covered by this specification document are subject to Mini-Circuits standard limited warranty and terms and conditions (collectively, "Standard Terms"); Purchasers of this part are entitled to the rights and benefits contained therein. For a full statement of the Standard Terms and the exclusive rights and remedies thereunder, please visit Mini-Circuits' website at www.minicircuits.com/MCLStore/terms.jsp



2 Way-0° Power Splitter/Combiner

ZB2PD-63+

Typical Performance Data

FREQUENCY (MHz)	TOTAL LOSS ¹ (dB)		AMPLITUDE UNBALANCE (dB)	ISOLATION (dB) 1-2	PHASE UNBALANCE (deg.)	FREQUENCY (MHz)	VSWR		
	S-1	S-2					S	(:1) 1	2
10.0	3.54	3.53	0.01	3.60	0.55	10.0	1.98	2.00	1.98
50.0	3.54	3.53	0.01	4.53	0.06	50.0	1.79	1.97	1.79
90.0	3.52	3.51	0.00	6.06	0.03	90.0	1.56	1.93	1.56
100.0	3.51	3.51	0.00	6.47	0.04	100.0	1.51	1.92	1.50
150.0	3.46	3.47	0.01	8.46	0.00	150.0	1.30	1.84	1.30
200.0	3.41	3.42	0.01	10.38	0.05	200.0	1.17	1.75	1.17
250.0	3.34	3.35	0.01	12.32	0.06	250.0	1.08	1.64	1.09
300.0	3.28	3.29	0.01	14.45	0.08	300.0	1.06	1.53	1.06
350.0	3.23	3.23	0.01	17.00	0.08	350.0	1.09	1.43	1.09
400.0	3.18	3.19	0.01	20.35	0.09	400.0	1.12	1.34	1.12
500.0	3.13	3.14	0.01	35.93	0.11	500.0	1.15	1.18	1.15
600.0	3.11	3.12	0.01	26.85	0.12	600.0	1.13	1.07	1.12
700.0	3.13	3.13	0.01	21.82	0.14	700.0	1.07	1.09	1.07
800.0	3.15	3.16	0.01	21.06	0.16	800.0	1.09	1.15	1.08
900.0	3.17	3.18	0.01	23.02	0.19	900.0	1.15	1.19	1.14
1000.0	3.17	3.18	0.01	28.44	0.21	1000.0	1.18	1.17	1.18
1200.0	3.17	3.18	0.01	23.85	0.26	1200.0	1.12	1.07	1.11
1400.0	3.23	3.24	0.01	20.24	0.30	1400.0	1.06	1.23	1.06
1600.0	3.23	3.24	0.01	26.05	0.37	1600.0	1.14	1.21	1.13
1800.0	3.22	3.23	0.01	29.26	0.43	1800.0	1.09	1.12	1.08
2000.0	3.26	3.27	0.00	21.95	0.50	2000.0	1.03	1.22	1.04
2500.0	3.28	3.27	0.01	22.59	0.72	2500.0	1.07	1.09	1.07
2700.0	3.32	3.30	0.02	22.99	0.77	2700.0	1.15	1.19	1.17
3000.0	3.35	3.32	0.03	36.64	0.74	3000.0	1.21	1.23	1.26
3200.0	3.35	3.32	0.03	28.51	0.69	3200.0	1.16	1.08	1.21
3400.0	3.36	3.33	0.02	30.38	0.64	3400.0	1.19	1.13	1.22
3600.0	3.36	3.35	0.02	26.45	0.71	3600.0	1.15	1.09	1.16
3700.0	3.37	3.36	0.01	25.29	0.70	3700.0	1.12	1.03	1.13
3800.0	3.36	3.37	0.00	25.45	0.72	3800.0	1.11	1.02	1.12
3900.0	3.37	3.37	0.00	26.66	0.81	3900.0	1.12	1.04	1.12
4000.0	3.38	3.38	0.00	27.59	0.83	4000.0	1.11	1.03	1.10
4500.0	3.43	3.44	0.00	44.56	1.08	4500.0	1.15	1.12	1.15
5000.0	3.69	3.66	0.02	32.45	1.33	5000.0	1.35	1.37	1.35
5500.0	3.58	3.52	0.06	30.77	1.64	5500.0	1.32	1.28	1.33
5800.0	3.74	3.63	0.10	19.25	1.82	5800.0	1.35	1.43	1.34
5900.0	3.75	3.61	0.13	17.33	1.77	5900.0	1.35	1.30	1.35
6000.0	3.68	3.53	0.15	16.13	1.64	6000.0	1.45	1.33	1.45
6500.0	4.08	4.08	0.00	7.34	1.42	6500.0	1.26	2.07	1.20
7000.0	4.00	3.80	0.20	12.55	2.47	7000.0	1.16	1.68	1.16
8000.0	4.96	4.69	0.28	33.09	0.21	8000.0	2.54	2.61	2.60

¹Total Loss = Insertion Loss + 3dB Splitter Loss



2 Way-0° Power Splitter/Combiner

ZB2PD-63+

Typical Performance Curves

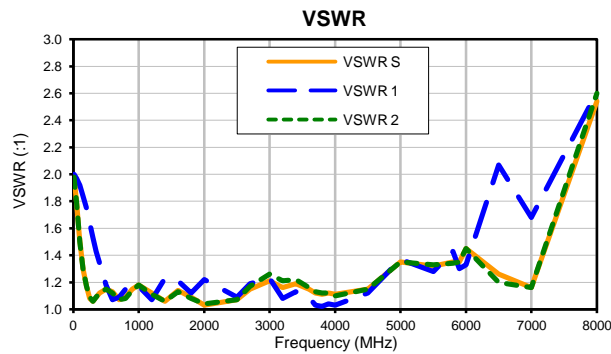
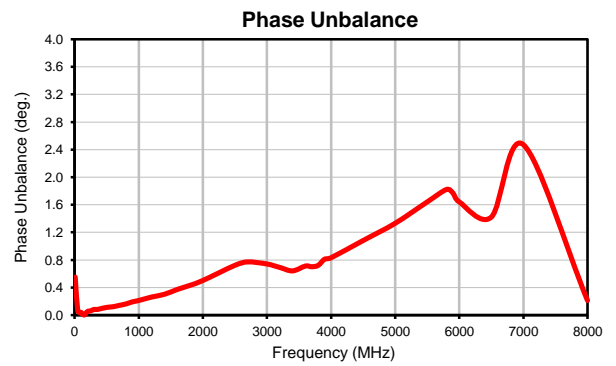
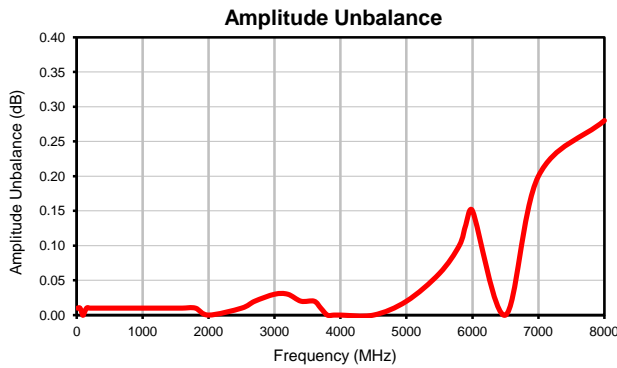
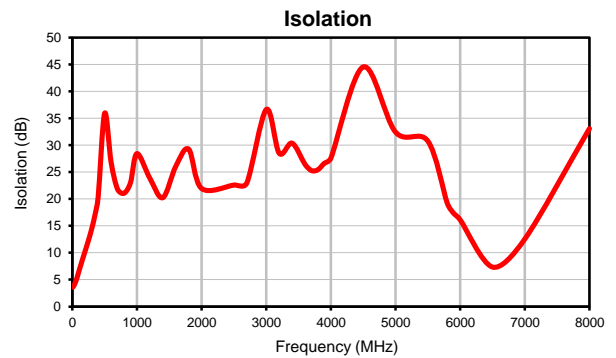
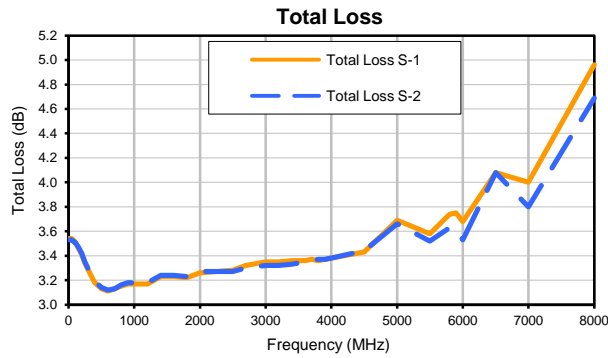

P.O. Box 350166, Brooklyn, New York 11235-0003 (718) 934-4500 • Fax (718) 332-4661 For detailed performance specs & shopping online see Mini-Circuits web site
The Design Engineers Search Engine Provides ACTUAL Data Instantly From MINI-CIRCUITS At: www.minicircuits.com



IF/RF MICROWAVE COMPONENTS

REV. OR
ZB2PD-63+
1/15/2015
Page 1 of 1

Outline Dimensions

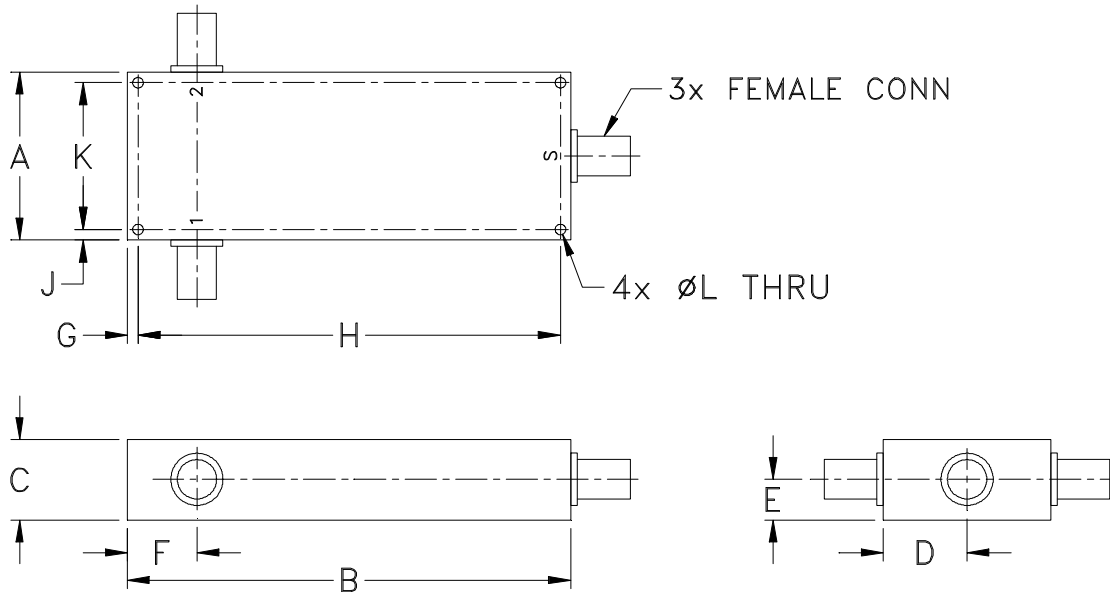

CASE#	A	B	C	D	E	F	G	H	J	K	L	WT. GRAM
JJJ1457	1.99 (50.55)	5.26 (133.60)	.95 (24.13)	1.00 (25.40)	.51 (12.95)	.83 (21.08)	.13 (3.30)	5.010 (127.25)	.13 (3.30)	1.740 (44.20)	.125 (3.18)	350

Dimensions are in inches (mm). Tolerances: 2 Pl. $\pm .03$; 3 Pl. $\pm .015$

Notes:

- Case material: Aluminum alloy.
- Case finish:
For RoHS Case Styles: Clear chemical conversion coating, non-chrome or trivalent chrome based.



INTERNET <http://www.minicircuits.com>

P.O. Box 350166, Brooklyn, New York 11235-0003 (718) 934-4500 Fax (718) 332-4661

Distribution Centers NORTH AMERICA 800-654-7949 • 417-335-5935 • Fax 417-335-5945 • EUROPE 44-1252-832600 • Fax 44-1252-837010

Mini-Circuits ISO 9001 & ISO 14001 Certified



All Mini-Circuits products are manufactured under exacting quality assurance and control standards, and are capable of meeting published specifications after being subjected to any or all of the following physical and environmental test.

Specification	Test/Inspection Condition	Reference/Spec
Operating Temperature	-55° to 100°C Ambient Environment	Individual Model Data Sheet
Storage Temperature	-55° to 100° C Ambient Environment	Individual Model Data Sheet
Barometric Pressure	100,000 Feet	MIL-STD-202, Method 105, Condition D
Humidity	90% RH, 65°C Units may require bake-out after humidity to restore full performance.	MIL-STD-202, Method 103
Thermal Shock	-65° to 125°C, 5 cycles	MIL-STD-202, Method 107, Condition B
Vibration (High Frequency)	20g peak, 10-2000 Hz, 12 times in each of three perpendicular directions (total 36)	MIL-STD-202, Method 204, Condition D
Mechanical Shock	100g, 6ms sawtooth, 3 shocks each direction 3 axes (total 18)	MIL-STD-202, Method 213, Condition I