

# High Power Power Splitter/Combiner

## ZAPDJ2-5W-521+

2 Way-180° 50Ω 10 to 520 MHz

### Maximum Ratings

Operating Temperature	-55°C to 100°C
Storage Temperature	-55°C to 100°C
Power Input (as a splitter)	5W
Internal Dissipation	1W

Permanent damage may occur if any of these limits are

### Coaxial Connections

SUM PORT	1
PORT 1 (0°)	4
PORT 2 (180°)	3
NOTE USED	2

### Outline Drawing

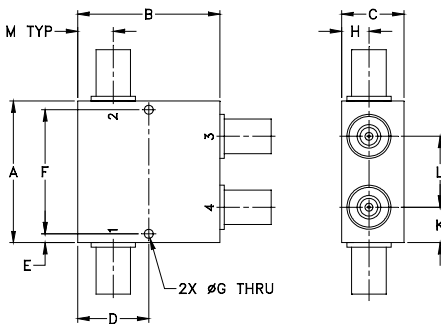

### Outline Dimensions (inch/mm)

A	B	C	D	E	F	G
2.00	2.00	.88	1.000	0.13	1.750	0.125
50.80	50.80	22.35	25.40	3.30	44.45	3.18

H	J	K	L	M	wt
0.38	--	0.50	1.00	0.50	grams
9.65	--	12.70	25.40	12.70	250.0

### Electrical Schematic



### Features

- wideband, 10 to 520 MHz
- low phase unbalance, 2 deg. typ.
- low amplitude unbalance, 0.1 dB typ.
- high isolation, 23 dB typ.
- high input power as a splitter, 5.0 W

### Applications

- VHF/UHF
- communication systems
- receivers & transmitters
- instrumentation
- CATV



Generic photo used for illustration purposes only  
SMA version shown

CASE STYLE: JD1252

Connectors	Model
SMA	ZAPDJ2-5W-521S+
N-Type	ZAPDJ2-5W-521N+
BNC	ZAPDJ2-5W-521+

**+RoHS Compliant**

The +Suffix identifies RoHS Compliance. See our web site for RoHS Compliance methodologies and qualifications

### Electrical Specifications at 25°C

Parameter	Frequency (MHz)	Min.	Typ.	Max.	Unit
<b>Frequency</b>		10		520	MHz
<b>Insertion Loss (above theoretical 3.0 dB)</b>	10 - 250 250 - 520	—	0.5 0.9	0.9 1.5	dB
<b>Isolation</b>	10 - 250 250 - 520	17 18	22 24	—	dB
<b>Phase Unbalance</b>	10 - 250 250 - 520	—	2.0 2.0	8.0 10	Degree
<b>Amplitude Unbalance</b>	10 - 250 250 - 520	—	0.05 0.1	0.2 0.35	dB
<b>VSWR (Port S)</b>	10 - 250 250 - 520	—	1.4 1.5	1.55 1.95	:1
<b>VSWR (Port 1-2)</b>	10 - 250 250 - 520	—	1.35 1.6	1.65 2.3	:1
<b>Input Power</b>					W
	as splitter	10 - 520	—	5.0	
	as combiner	10 - 520	—	1.0	

### Typical Performance Data

Frequency (MHz)	Total Loss <sup>1</sup> (dB)		Amplitude Unbalance (dB)	Isolation (dB)	Phase Unbalance (deg.)	VSWR S	VSWR 1	VSWR 2
	S-1	S-2						
10	3.38	3.31	0.08	24.18	179.96	1.39	1.22	1.22
50	3.45	3.42	0.02	22.24	179.43	1.10	1.26	1.20
100	3.48	3.47	0.01	21.23	179.08	1.12	1.32	1.22
160	3.52	3.51	0.01	21.67	178.76	1.15	1.38	1.22
200	3.56	3.55	0.01	22.43	178.60	1.18	1.42	1.22
250	3.62	3.60	0.02	24.19	178.48	1.22	1.47	1.25
300	3.69	3.66	0.04	27.05	178.46	1.26	1.52	1.30
360	3.79	3.75	0.04	33.32	178.69	1.32	1.59	1.41
400	3.87	3.82	0.04	35.05	179.07	1.38	1.65	1.51
525	4.17	4.09	0.08	22.57	178.05	1.60	1.91	1.93

1. Total Loss = Insertion Loss + 3dB splitter theoretical loss.

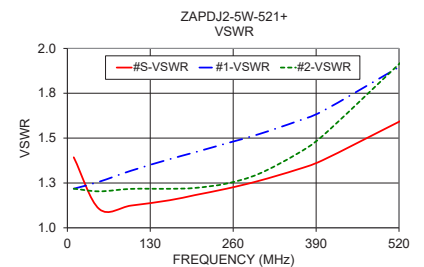
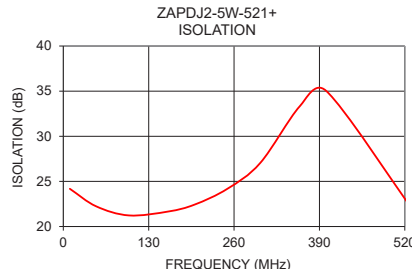
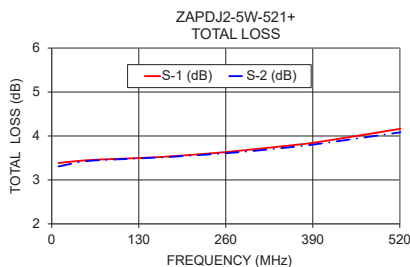

### Notes

- Performance and quality attributes and conditions not expressly stated in this specification document are intended to be excluded and do not form a part of this specification document.
- Electrical specifications and performance data contained in this specification document are based on Mini-Circuits' applicable established test performance criteria and measurement instructions.
- The parts covered by this specification document are subject to Mini-Circuits standard limited warranty and terms and conditions (collectively, "Standard Terms"); Purchasers of this part are entitled to the rights and benefits contained therein. For a full statement of the Standard Terms and the exclusive rights and remedies thereunder, please visit Mini-Circuits' website at [www.minicircuits.com/MCLStore/terms.jsp](http://www.minicircuits.com/MCLStore/terms.jsp)



## Typical Performance Data

FREQUENCY (MHz)	TOTAL LOSS <sup>1</sup> (dB)		AMPLITUDE UNBALANCE (dB)	ISOLATION (dB) 1-2	PHASE UNBALANCE (deg.)	FREQUENCY (MHz)	VSWR (:1)		
	S-1	S-2					S	1	2
5	3.71	3.63	0.08	16.78	179.77	5	1.90	1.37	1.39
6	3.57	3.50	0.07	18.46	179.84	6	1.72	1.31	1.33
7	3.49	3.42	0.08	19.99	179.90	7	1.59	1.28	1.29
8	3.44	3.36	0.08	21.43	179.96	8	1.51	1.25	1.26
9	3.40	3.33	0.08	22.80	179.99	9	1.44	1.23	1.24
10	3.38	3.31	0.08	24.18	179.96	10	1.39	1.22	1.22
30	3.36	3.32	0.04	26.02	179.48	30	1.13	1.23	1.20
50	3.45	3.42	0.02	22.24	179.43	50	1.10	1.26	1.20
70	3.46	3.45	0.02	21.61	179.28	70	1.11	1.28	1.21
90	3.47	3.46	0.01	21.27	179.15	90	1.12	1.31	1.22
100	3.48	3.47	0.01	21.23	179.08	100	1.12	1.32	1.22
120	3.49	3.48	0.01	21.26	178.97	120	1.14	1.34	1.22
140	3.50	3.50	0.01	21.42	178.85	140	1.14	1.36	1.22
160	3.52	3.51	0.01	21.67	178.76	160	1.15	1.38	1.22
180	3.54	3.53	0.01	21.95	178.67	180	1.17	1.40	1.22
200	3.56	3.55	0.01	22.43	178.60	200	1.18	1.42	1.22
220	3.58	3.57	0.02	23.06	178.54	220	1.19	1.44	1.23
240	3.61	3.59	0.02	23.78	178.49	240	1.21	1.46	1.24
250	3.62	3.60	0.02	24.19	178.48	250	1.22	1.47	1.25
260	3.63	3.61	0.03	24.66	178.46	260	1.23	1.48	1.25
280	3.66	3.63	0.03	25.71	178.45	280	1.24	1.50	1.27
300	3.69	3.66	0.04	27.05	178.46	300	1.26	1.52	1.30
320	3.72	3.69	0.04	28.72	178.51	320	1.28	1.54	1.33
340	3.76	3.72	0.04	30.84	178.58	340	1.30	1.57	1.37
360	3.79	3.75	0.04	33.32	178.69	360	1.32	1.59	1.41
380	3.83	3.79	0.04	35.39	178.86	380	1.35	1.62	1.46
400	3.87	3.82	0.04	35.05	179.07	400	1.38	1.65	1.51
420	3.91	3.86	0.04	32.57	179.33	420	1.41	1.68	1.57
440	3.95	3.91	0.04	29.94	179.66	440	1.44	1.71	1.63
460	4.00	3.95	0.05	27.65	179.93	460	1.47	1.75	1.69
480	4.04	3.99	0.05	25.76	179.45	480	1.51	1.79	1.76
500	4.10	4.04	0.06	24.18	178.88	500	1.55	1.84	1.84
525	4.17	4.09	0.08	22.57	178.05	525	1.60	1.91	1.93
550	4.26	4.15	0.11	21.21	177.10	550	1.66	1.98	2.03
575	4.35	4.20	0.15	20.05	175.97	575	1.72	2.07	2.13
600	4.45	4.24	0.21	19.07	174.69	600	1.79	2.17	2.24
650	4.71	4.32	0.39	17.54	171.69	650	1.95	2.42	2.45

<sup>1</sup>Total Loss = Insertion Loss + 3dB Splitter Loss

## Typical Performance Curves

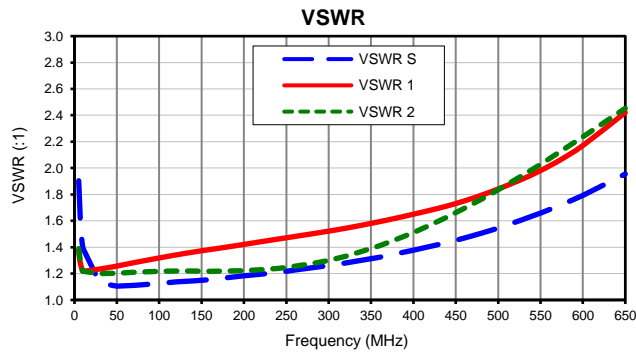
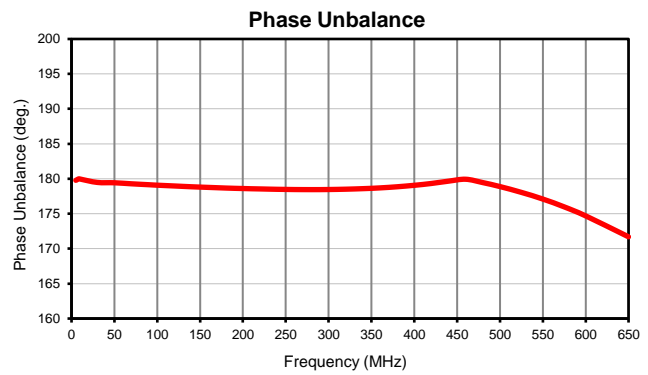
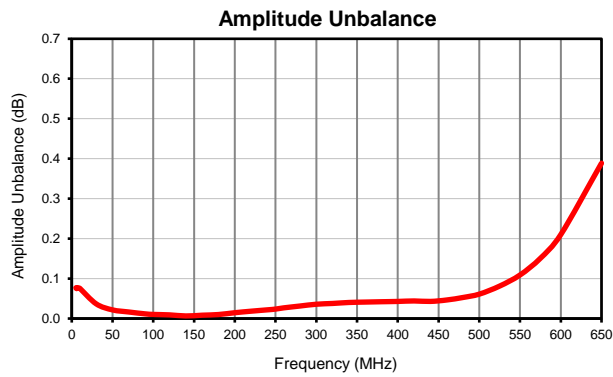
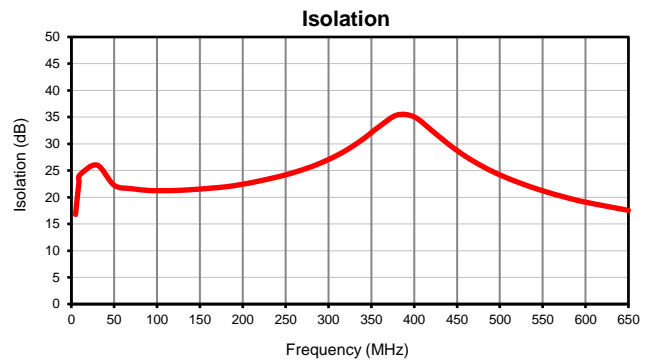
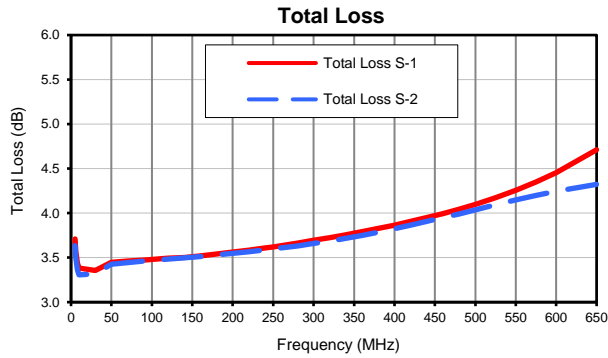

### Outline Dimensions

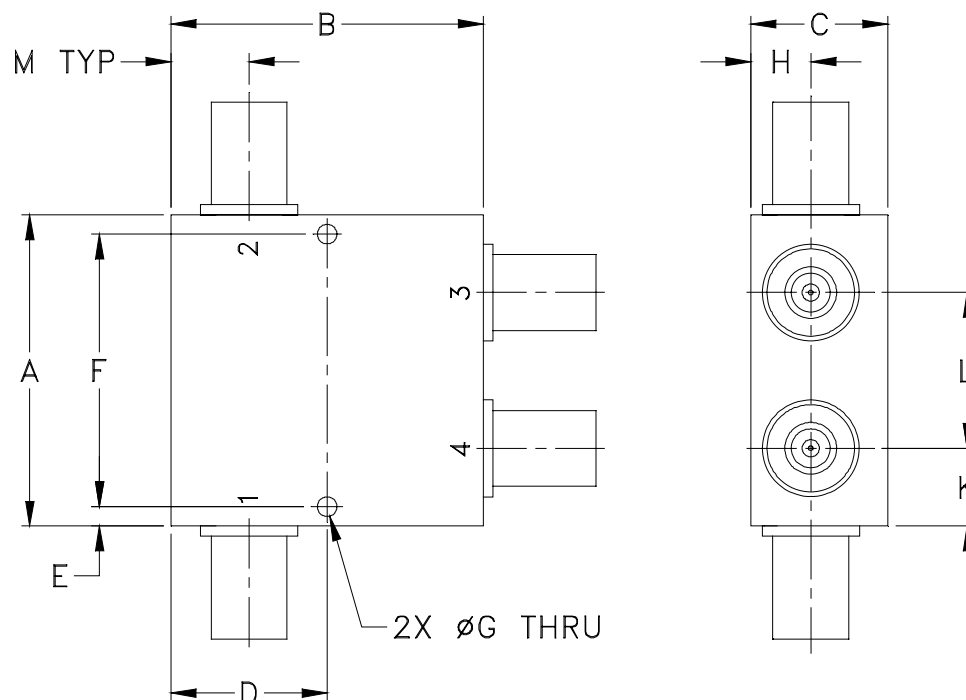

CASE#	A	B	C	D	E	F	G	H	J	K	L	M	WT, GRAM
JD1252	2.00 (50.80)	2.00 (50.80)	0.88 (22.35)	1.000 (25.40)	0.13 (3.18)	1.750 (44.45)	0.125 (3.18)	0.38 (9.65)	-- --	0.50 (12.70)	1.00 (25.40)	0.50 (12.70)	250.00

Dimensions are in inches (mm). Tolerances: 2 Pl.  $\pm .03$ ; 3 Pl.  $\pm .015$

#### Notes:

- Case material: Aluminum alloy.
- Case finish:  
For RoHS Case Styles: Clear chemical conversion coating, non-chrome or trivalent chrome based.



INTERNET <http://www.minicircuits.com>

P.O. Box 350166, Brooklyn, New York 11235-0003 (718) 934-4500 Fax (718) 332-4661

Distribution Centers NORTH AMERICA 800-654-7949 • 417-335-5935 • Fax 417-335-5945 • EUROPE 44-1252-832600 • Fax 44-1252-837010

Mini-Circuits ISO 9001 & ISO 14001 Certified

All Mini-Circuits products are manufactured under exacting quality assurance and control standards, and are capable of meeting published specifications after being subjected to any or all of the following physical and environmental test.

Specification	Test/Inspection Condition	Reference/Spec
Operating Temperature	-55° to 100°C Ambient Environment	Individual Model Data Sheet
Storage Temperature	-55° to 100° C Ambient Environment	Individual Model Data Sheet
Barometric Pressure	100,000 Feet	MIL-STD-202, Method 105, Condition D
Humidity	90% RH, 65°C Units may require bake-out after humidity to restore full performance.	MIL-STD-202, Method 103
Thermal Shock	-65° to 125°C, 5 cycles	MIL-STD-202, Method 107, Condition B
Vibration (High Frequency)	20g peak, 10-2000 Hz, 12 times in each of three perpendicular directions (total 36)	MIL-STD-202, Method 204, Condition D
Mechanical Shock	100g, 6ms sawtooth, 3 shocks each direction 3 axes (total 18)	MIL-STD-202, Method 213, Condition I