

High Power, DC Pass

Power Splitter/Combiner

ZACS622-100W+

2 Way-0° 50Ω Up to 100W 650 to 6200 MHz

The Big Deal

- High power, up to 100W as a splitter
- Low insertion loss, 0.5 dB
- High isolation, 22 dB



ZACS622-100WS+



ZACS622-100WSX+

Product Overview

Mini-Circuits' ZACS622-100W+ is a 2-way 0° splitter/combiner providing very high power handling and low insertion loss across 650 to 6200 MHz, covering the primary wireless communications bands as well as UHF, SatCom, and more. Its outstanding combination of high power and low loss minimize power dissipation due to intrinsic losses and provide excellent signal fidelity from input to output. This model also provides high port-to-port isolation and very low amplitude and phase unbalance. It comes housed in a rugged aluminum alloy case (3.19 x 4.18 x 4.09") with your choice of SMA or N-Type connectors and an optional heat sink and fan for cooling.

Key Features

Feature	Advantages
Wideband, 650 to 6200 MHz	ZACS622-100W+ covers many wireless communications bands, making it suitable for a wide variety of applications.
High power handling: <ul style="list-style-type: none">• 100W as a splitter• 5W as a combiner	Suitable for many high power applications.
Low insertion loss, 0.5 dB	Very low insertion loss minimizes intrinsic losses, making this model a suitable candidate for high power signal distribution applications where low loss is a requirement.
Low unbalance: <ul style="list-style-type: none">• 0.15 dB amplitude unbalance• 2° phase unbalance	ZACS622-100W+ produces nearly equal output signals, ideal for parallel path / multichannel systems.
DC Passing, 1.6A (0.8A each port)	Supports applications where DC power is needed at later stages in the system.

Notes

- A. Performance and quality attributes and conditions not expressly stated in this specification document are intended to be excluded and do not form a part of this specification document.
B. Electrical specifications and performance data contained in this specification document are based on Mini-Circuit's applicable established test performance criteria and measurement instructions.
C. The parts covered by this specification document are subject to Mini-Circuits standard limited warranty and terms and conditions (collectively, "Standard Terms"); Purchasers of this part are entitled to the rights and benefits contained therein. For a full statement of the Standard Terms and the exclusive rights and remedies thereunder, please visit Mini-Circuits' website at www.minicircuits.com/MCLStore/terms.jsp



High Power DC Pass Power Splitter/Combiner

ZACS622-100W+

2 Way-0° 50Ω Up to 100W 650 to 6200 MHz

Maximum Ratings

Operating Temperature	-55°C to 75°C
Storage Temperature	-55°C to 100°C
DC PASS	1.6A (0.8A/each port)
FAN DC Supply	24V
FAN Current	0.15A
Permanent damage may occur if any of these limits are exceeded.	

Coaxial Connections

SUM PORT	S
PORT 1	1
PORT 2	2

Outline Drawing

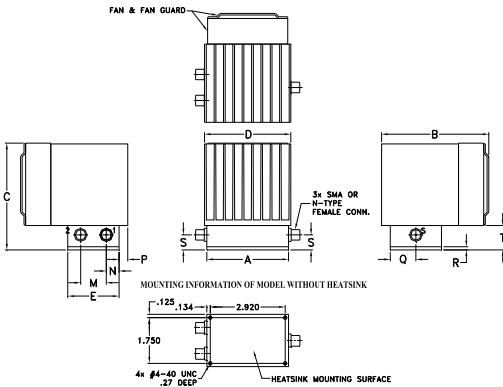

Outline Dimensions (inch/mm)

A	B	C	D	E	F	G	H	J	K
3.19	4.18	4.09	3.36	2.00	--	--	--	--	--
81.03	106.17	103.89	85.34	50.80	--	--	--	--	--
L	M	N	P	Q	R	S	T	wt	
--	1.00	.50	.34	1.00	.13	.58	.94	grams*	
--	25.40	12.70	8.64	25.40	3.30	14.73	23.88	710.0	
									*190 grams without heatsink

Electrical Schematic

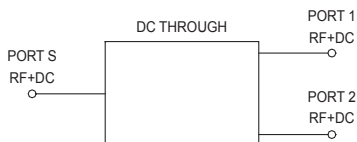

Features

- high power, up to 100W as splitter
- high power, up to 2.0W as combiner
- low insertion loss, 0.5 dB typ.
- high isolation, 22 dB typ.
- excellent VSWR, 1.20 typ.

Applications

- UHF TV
- MMDC
- SATCOM
- cellular/ISM/SMG/GSM
- satellite distribution
- GPS/L BAND (MARSAT)
- PCS/DCS/UMTS



ZACS622-100WS+



ZACS622-100WSX+

Generic photo used for illustration purposes only

CASE STYLE: CP1829

Connectors	Model
SMA	ZACS622-100WS+
SMA	ZACS622-100WSX+ [▲]
N-TYPE	ZACS622-100WN+
N-TYPE	ZACS622-100WNX+ [▲]

+RoHS Compliant

The +Suffix identifies RoHS Compliance. See our web site for RoHS Compliance methodologies and qualifications

Electrical Specifications at 25°C

Parameter	Frequency (MHz)	Min.	Typ.	Max.	Unit
Frequency Range		650		6200	MHz
Insertion Loss Above 3.0 dB	1000-1500	—	0.3	0.6	dB
	1500-4000	—	0.3	0.7	
	4000-6000	—	0.5	0.8	
	650-6200	—	0.5	1.1	
Isolation	1000-1500	14.0	20	—	dB
	1500-4000	20	25	—	
	4000-6000	19	24	—	
	650-6200	10	22	—	
Phase Unbalance	1000-1500	—	0.5	2.0	Degree
	1500-4000	—	1.0	4.0	
	4000-6000	—	2.0	5.0	
	650-6200	—	2.0	6.0	
Amplitude Unbalance	1000-1500	—	0.1	0.2	dB
	1500-4000	—	0.1	0.3	
	4000-6000	—	0.15	0.4	
	650-6200	—	0.15	0.5	
VSWR (Port S)	1000-1500	—	1.40	1.75	:1
	1500-4000	—	1.15	1.35	
	4000-6000	—	1.30	1.65	
	650-6200	—	1.50	2.05	
VSWR (Port 1-2)	1000-1500	—	1.15	1.25	:1
	1500-4000	—	1.15	1.25	
	4000-6000	—	1.20	1.40	
	650-6200	—	1.20	1.55	
Power Input	as combiner ²	650-6200	—	5	W
	as splitter ¹	650-3600	—	100	
		3600-6200	—	50	

1. Over -55°C to +55°C. Derate linearly to 20% of rating at 75°C. All outputs must terminate 50 ohm (VSWR 1.5:1 or better)
2. As a combiner of non-coherent signals, max. power per port is 2.5W.

[▲]Heat sink and fan not included. Alternative heat sinking and heat removal must be provided by the user to limit maximum base-plate temperature to 55°C, in order to ensure proper performance. For reference, this requires thermal resistance of user's external heat sink to be 1.3°C/W max.

Notes

- A. Performance and quality attributes and conditions not expressly stated in this specification document are intended to be excluded and do not form a part of this specification document.
- B. Electrical specifications and performance data contained in this specification document are based on Mini-Circuit's applicable established test performance criteria and measurement instructions.
- C. The parts covered by this specification document are subject to Mini-Circuits standard limited warranty and terms and conditions (collectively, "Standard Terms"); Purchasers of this part are entitled to the rights and benefits contained therein. For a full statement of the Standard Terms and the exclusive rights and remedies thereunder, please visit Mini-Circuits' website at www.minicircuits.com/WCLStore/terms.jsp



Typical Performance Data

Frequency (MHz)	Total Loss ¹ (dB)		Amplitude Unbalance (dB)	Isolation (dB)	Phase Unbalance (deg.)	VSWR S	VSWR 1	VSWR 2
	S-1	S-2						
650	3.47	3.44	0.03	11.91	0.04	1.75	1.22	1.21
750	3.42	3.40	0.03	13.14	0.07	1.69	1.18	1.17
850	3.40	3.36	0.04	14.44	0.01	1.62	1.16	1.14
1000	3.33	3.30	0.03	16.63	0.06	1.52	1.14	1.11
1500	3.21	3.17	0.03	27.95	0.10	1.18	1.10	1.09
2000	3.20	3.18	0.02	27.88	0.18	1.09	1.07	1.07
2500	3.22	3.20	0.02	25.75	0.18	1.09	1.03	1.04
3000	3.25	3.24	0.01	27.40	0.26	1.10	1.03	1.04
3500	3.26	3.25	0.00	31.22	0.24	1.04	1.07	1.07
4000	3.32	3.34	0.03	23.98	0.24	1.20	1.12	1.12
4500	3.35	3.35	0.00	24.60	0.07	1.29	1.18	1.15
5000	3.33	3.36	0.03	34.89	0.29	1.13	1.07	1.12
5500	3.42	3.50	0.09	23.41	0.09	1.43	1.23	1.27
6000	3.42	3.48	0.06	38.31	0.23	1.21	1.18	1.17
6200	3.63	3.69	0.06	22.71	0.27	1.57	1.37	1.33

1. Total Loss = Insertion Loss + 3dB splitter theoretical loss.

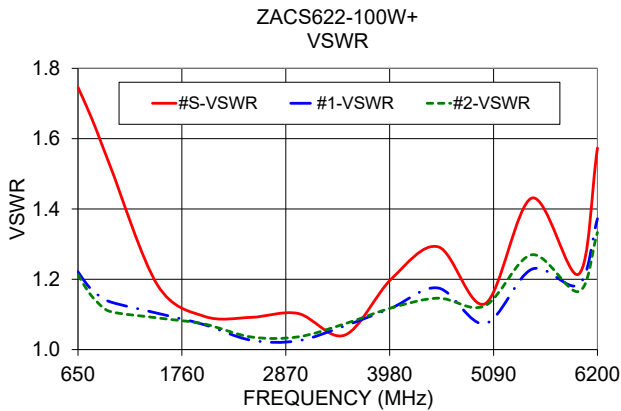
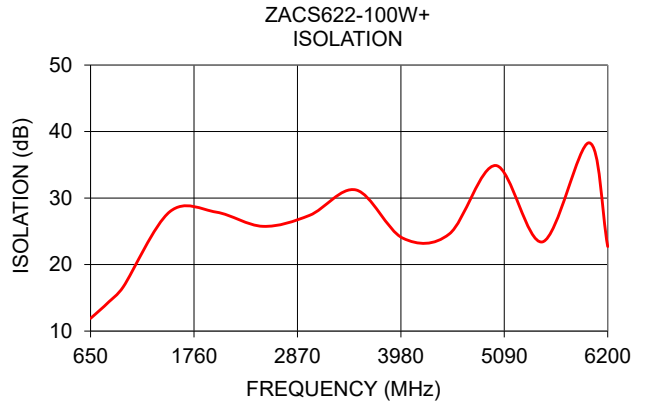
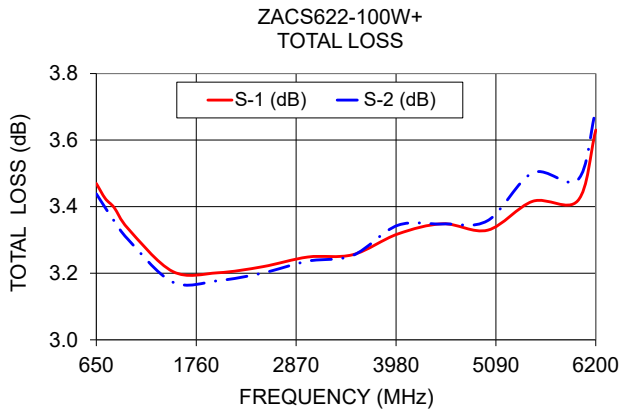

Notes

- A. Performance and quality attributes and conditions not expressly stated in this specification document are intended to be excluded and do not form a part of this specification document.
- B. Electrical specifications and performance data contained in this specification document are based on Mini-Circuit's applicable established test performance criteria and measurement instructions.
- C. The parts covered by this specification document are subject to Mini-Circuits standard limited warranty and terms and conditions (collectively, "Standard Terms"); Purchasers of this part are entitled to the rights and benefits contained therein. For a full statement of the Standard Terms and the exclusive rights and remedies thereunder, please visit Mini-Circuits' website at www.minicircuits.com/MCLStore/terms.jsp



2 Way-0° Power Splitter/Combiner

ZACS622-100W+

Typical Performance Data

FREQUENCY (MHz)	TOTAL LOSS ¹ (dB)		AMPLITUDE UNBALANCE (dB)	ISOLATION (dB)	PHASE UNBALANCE (deg.)	FREQUENCY (MHz)	VSWR (:1)		
	S-1	S-2					S	1	2
400	3.53	3.52	0.01	8.71	0.11	400	1.87	1.39	1.39
500	3.51	3.49	0.03	10.03	0.10	500	1.82	1.31	1.30
600	3.48	3.46	0.02	11.30	0.07	600	1.77	1.24	1.24
650	3.47	3.44	0.03	11.91	0.04	650	1.75	1.22	1.21
700	3.45	3.41	0.04	12.51	0.07	700	1.72	1.20	1.19
800	3.41	3.38	0.03	13.79	0.01	800	1.66	1.17	1.15
900	3.37	3.33	0.04	15.13	0.05	900	1.59	1.15	1.12
1000	3.33	3.30	0.03	16.63	0.06	1000	1.52	1.14	1.11
1100	3.30	3.26	0.04	18.29	0.01	1100	1.45	1.13	1.10
1200	3.27	3.23	0.03	20.22	0.12	1200	1.37	1.12	1.10
1300	3.24	3.20	0.04	22.46	0.04	1300	1.30	1.11	1.09
1400	3.22	3.19	0.03	25.08	0.17	1400	1.24	1.11	1.09
1500	3.21	3.17	0.03	27.95	0.10	1500	1.18	1.10	1.09
1600	3.20	3.17	0.04	30.44	0.20	1600	1.14	1.10	1.09
1700	3.19	3.17	0.02	31.17	0.14	1700	1.11	1.09	1.09
1800	3.20	3.17	0.03	30.21	0.20	1800	1.10	1.09	1.08
1900	3.19	3.18	0.01	28.96	0.18	1900	1.09	1.08	1.08
2000	3.20	3.18	0.02	27.88	0.18	2000	1.09	1.07	1.07
2100	3.19	3.18	0.01	27.03	0.18	2100	1.10	1.06	1.07
2200	3.21	3.19	0.02	26.37	0.12	2200	1.10	1.05	1.06
2300	3.21	3.19	0.02	25.88	0.16	2300	1.10	1.04	1.05
2400	3.22	3.20	0.02	25.76	0.15	2400	1.10	1.03	1.04
2500	3.22	3.20	0.02	25.75	0.18	2500	1.09	1.03	1.04
2600	3.23	3.21	0.02	25.91	0.20	2600	1.10	1.02	1.03
2700	3.23	3.22	0.01	26.03	0.19	2700	1.10	1.02	1.02
2800	3.24	3.23	0.01	26.30	0.23	2800	1.10	1.02	1.02
2900	3.25	3.24	0.01	26.71	0.20	2900	1.10	1.02	1.03
3000	3.25	3.24	0.01	27.40	0.26	3000	1.10	1.03	1.04
3100	3.26	3.25	0.01	28.28	0.24	3100	1.10	1.03	1.05
3200	3.26	3.25	0.01	29.36	0.24	3200	1.09	1.04	1.05
3300	3.26	3.25	0.00	30.65	0.23	3300	1.07	1.05	1.06
3400	3.26	3.25	0.01	31.50	0.22	3400	1.06	1.06	1.07
3500	3.26	3.25	0.00	31.22	0.24	3500	1.04	1.07	1.07
3600	3.26	3.27	0.01	29.86	0.21	3600	1.04	1.07	1.08
3700	3.27	3.27	0.00	28.03	0.21	3700	1.07	1.07	1.08
3800	3.28	3.29	0.02	26.34	0.21	3800	1.11	1.08	1.09
3900	3.31	3.30	0.01	25.00	0.18	3900	1.15	1.10	1.10
4000	3.32	3.34	0.03	23.98	0.24	4000	1.20	1.12	1.12
4100	3.35	3.34	0.01	23.32	0.14	4100	1.25	1.14	1.14
4200	3.34	3.38	0.03	23.02	0.27	4200	1.29	1.16	1.16
4300	3.37	3.36	0.01	23.15	0.09	4300	1.31	1.18	1.16
4400	3.35	3.39	0.03	23.60	0.33	4400	1.32	1.18	1.16
4500	3.35	3.35	0.00	24.60	0.07	4500	1.29	1.18	1.15
4600	3.33	3.35	0.03	26.27	0.35	4600	1.24	1.15	1.12
4700	3.31	3.32	0.02	29.18	0.02	4700	1.17	1.11	1.08
4800	3.30	3.33	0.03	34.05	0.36	4800	1.08	1.06	1.04
4900	3.30	3.34	0.04	43.94	0.02	4900	1.03	1.03	1.06
5000	3.33	3.36	0.03	34.89	0.29	5000	1.13	1.07	1.12
5100	3.38	3.43	0.06	29.35	0.04	5100	1.24	1.13	1.19
5200	3.43	3.46	0.03	26.20	0.16	5200	1.34	1.19	1.24
5300	3.44	3.51	0.07	24.48	0.06	5300	1.42	1.23	1.28
5400	3.46	3.51	0.04	23.60	0.01	5400	1.45	1.24	1.29
5500	3.42	3.50	0.09	23.41	0.09	5500	1.43	1.23	1.27
5600	3.38	3.43	0.05	23.79	0.13	5600	1.36	1.19	1.23
5700	3.31	3.40	0.08	25.11	0.11	5700	1.24	1.13	1.16
5800	3.33	3.38	0.06	27.77	0.19	5800	1.10	1.06	1.09
5900	3.32	3.41	0.08	34.67	0.14	5900	1.05	1.09	1.09
6000	3.42	3.48	0.06	38.31	0.23	6000	1.21	1.18	1.17
6100	3.54	3.61	0.07	27.72	0.19	6100	1.40	1.29	1.26
6200	3.63	3.69	0.06	22.71	0.27	6200	1.57	1.37	1.33
6300	3.72	3.79	0.07	19.35	0.27	6300	1.73	1.43	1.38
6400	3.76	3.83	0.07	17.10	0.33	6400	1.83	1.44	1.39

¹Total Loss = Insertion Loss + 3dB Splitter Loss



2 Way-0° Power Splitter/Combiner

ZACS622-100W+

Typical Performance Curves

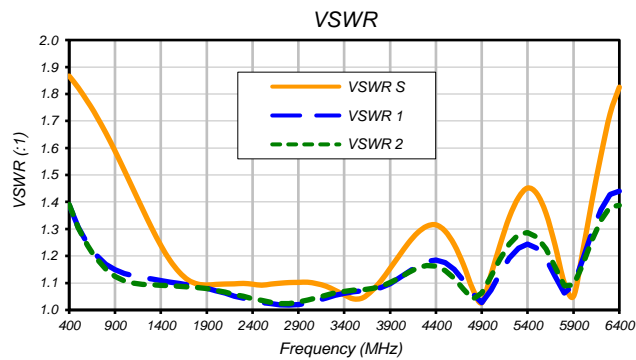
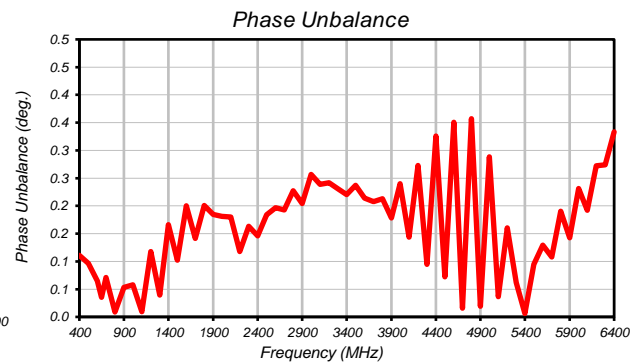
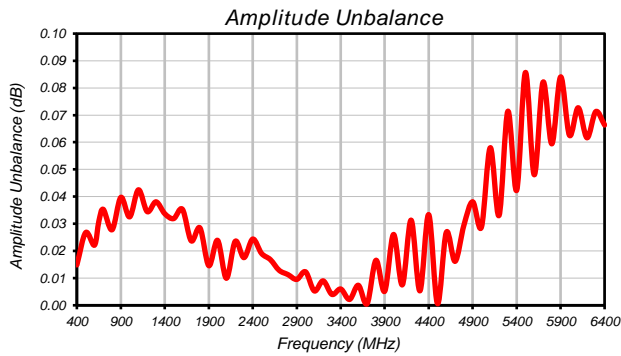
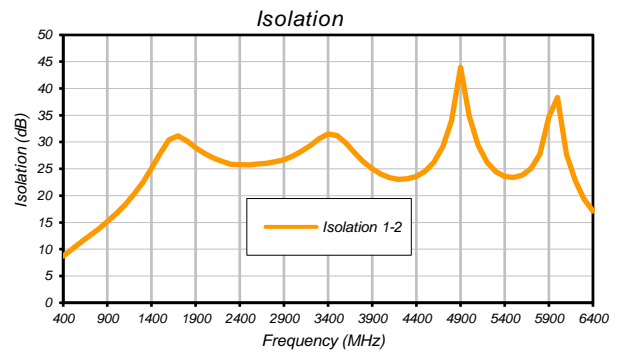
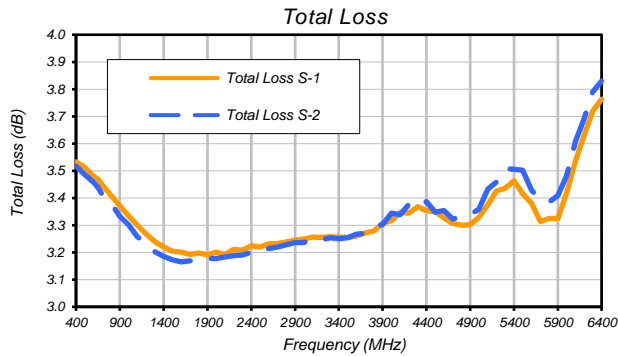

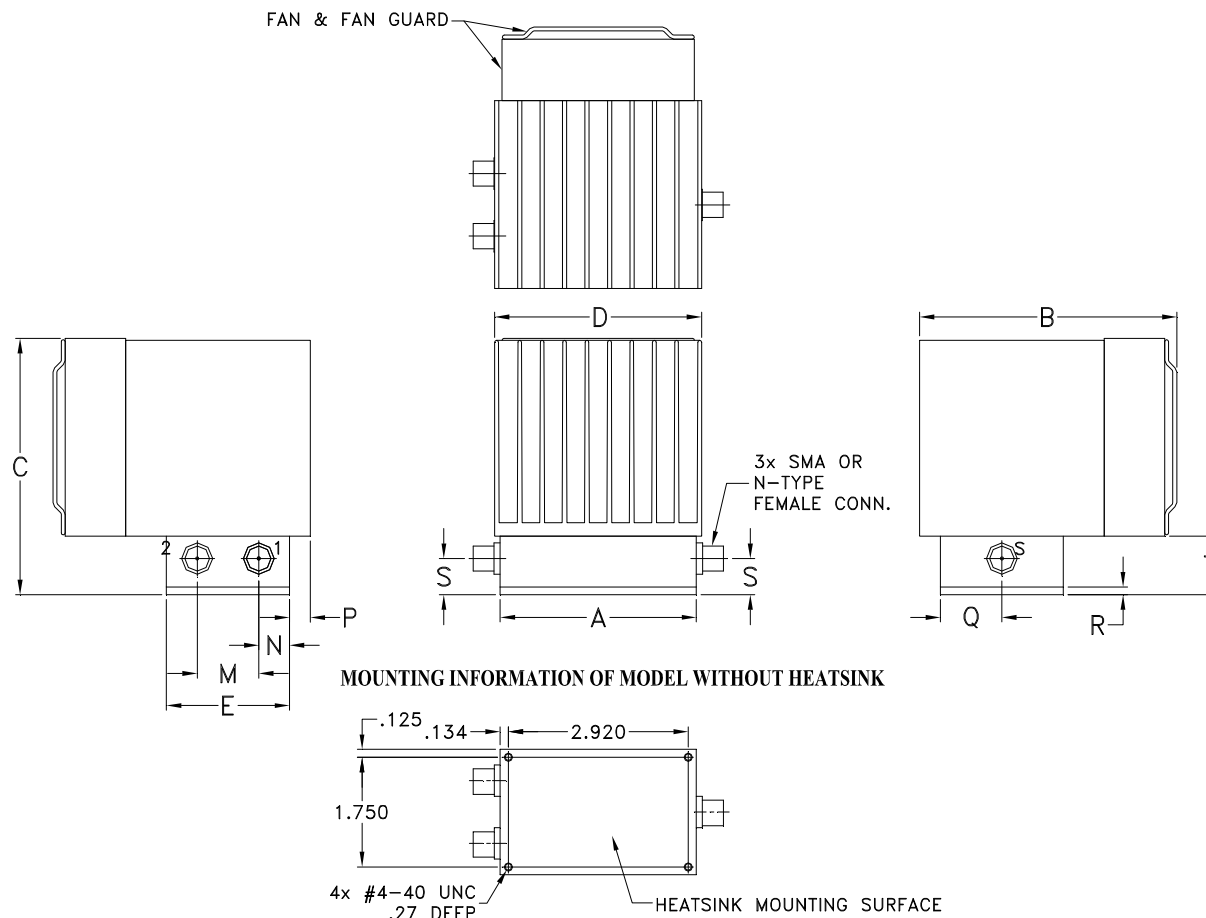

CASE#	A	B	C	D	E	F	G	H	J	K	L	M	N
CP1829	3.19 (80.98)	4.18 (106.17)	4.09 (103.89)	3.36 (85.34)	2.00 (50.80)	--	--	--	--	--	--	1.00 (25.40)	.50 (12.70)

CASE#	P	Q	R	S	T	WT. GRAMS	WT. WITHOUT HEATSINK GRAMS
CP1829	.34 (8.64)	1.00 (25.40)	.13 (3.30)	.58 (14.73)	.94 (23.88)	710	190

Dimensions are in inches (mm). Tolerances: 2 Pl. $\pm .03$; 3 Pl. $\pm .015$

Notes:

- Case material: Aluminum alloy.
- Case finish: For RoHS Case Styles: Clear chemical conversion coating, non-chrome or trivalent chrome base.
- Heat sink finish: Black anodize if supplied with heat sink.



P.O. Box 350166, Brooklyn, New York 11235-0003 (718) 934-4500 Fax (718) 332-4661 For detailed performance specs & shopping online see Mini-Circuits web site



The Design Engineers Search Engine Provides ACTUAL Data Instantly From MINI-CIRCUITS At: www.minicircuits.com

RF/MICROWAVE COMPONENTS



All Mini-Circuits products are manufactured under exacting quality assurance and control standards, and are capable of meeting published specifications after being subjected to any or all of the following physical and environmental test.

Specification	Test/Inspection Condition	Reference/Spec
Operating Temperature	-55° to 75°C Ambient Environment	Individual Model Data Sheet
Storage Temperature	-55° to 100° C Ambient Environment	Individual Model Data Sheet
Barometric Pressure	100,000 Feet	MIL-STD-202, Method 105, Condition D
Humidity	90% RH, 65°C Units may require bake-out after humidity to restore full performance.	MIL-STD-202, Method 103
Thermal Shock	-65° to 125°C, 5 cycles	MIL-STD-202, Method 107, Condition B
Vibration (High Frequency)	20g peak, 10-2000 Hz, 12 times in each of three perpendicular directions (total 36)	MIL-STD-202, Method 204, Condition D
Mechanical Shock	100g, 6ms sawtooth, 3 shocks each direction 3 axes (total 18)	MIL-STD-202, Method 213, Condition I