



MMIC REFLECTIONLESS

Low Pass Filter

XLF-42M+

50Ω DC to 300 MHz

THE BIG DEAL

- Match to 50Ω in the stop band, eliminates undesired reflections
- Cascadable
- Excellent stopband rejection, 49 dB typ.
- Temperature stable, up to +105°C
- Small size, 5 x 5 mm
- Protected by US Patents 8,392,495; 9,705,467, additional patent pending
- Protected by China Patent 201080014266.1
- Protected by Taiwan Patent I581494

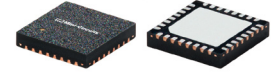

Generic photo used for illustration purposes only

CASE STYLE: DG1677-2

+RoHS Compliant

The +Suffix identifies RoHS Compliance. See our website for methodologies and qualifications

APPLICATIONS

- Aircraft / Military communications
- FM Radio
- Earth Exploration Satellite
- Radio Astronomy
- Mobile Satellite

PRODUCT OVERVIEW

Mini-Circuits' XLF-42M+ two-section reflectionless filter employs a novel filter topology which absorbs and terminates stop band signals internally rather than reflecting them back to the source. This new capability enables unique applications for filter circuits beyond those suited to traditional approaches. Traditional filters are reflective in the stop band, sending signals back to the source at 100% of the power level. These reflections interact with neighboring components and often result in inter-modulation and other interferences. Reflectionless filters eliminate stop band reflections, allowing them to be paired with sensitive devices and used in applications that otherwise require circuits such as isolation amplifiers or attenuators.

KEY FEATURES

Features	Advantages
Reflectionless Technology	Reflectionless filters absorb unwanted signals, preventing reflections back to the source. This reduces generation of additional unwanted signals without the need for extra components like attenuators, improving system dynamic range and saving board space.
50Ω Match in Stopband	Reflectionless filters maintain good impedance matching in the stopband, allowing for integration with high gain, wideband amplifiers without the risk of creating out-of-band instabilities.
Excellent RF Performance Repeatability	Fabricated on a GaAs process, X-series filters are inherently repeatable for large-volume production.
Excellent Stability over temperature	With ±0.3 dB variation over temperature, is ideal for use in wide temperature range applications without the need for additional temperature compensation.
Excellent Power Handling in a Compact Package	High power handling extends the usability of these filters to the transmit path for inter-stage filtering.

REV. A
ECO-020598
XLF-42M+
MCL NY
240109





ELECTRICAL SPECIFICATIONS¹ AT +25°C

Parameter	F#	Frequency (MHz)	Min.	Typ.	Max.	Unit
Passband	Insertion Loss	DC - F1	—	2.3	3.1	dB
	Frequency Cut-off	F2	—	3.0	—	dB
	VSWR	DC - F1	—	1.3	—	:1
Stopband	Rejection	F3 - F4	17	34	—	dB
		F4 - F5	41	49	—	dB
	VSWR	F3 - F4	—	1.3	—	:1
		F4 - F5	—	2.2	—	:1

1. Measured on Mini-Circuits Characterization Test Board TB-944-42M+

ABSOLUTE MAXIMUM RATINGS²

Parameter	Ratings
Operating Temperature	-55°C to +105°C
Storage Temperature	-65°C to +150°C
RF Power Input, Passband (DC-F1) ³	5.0 W at +25°C
RF Power Input, Stopband (F2-F5) ⁴	1.6 W at +25°C

- 2. Permanent damage may occur if any of these limits are exceeded.
- 3. Passband rating derates linearly to 2.5 W at 105°C ambient
- 4. Stopband rating derates linearly to 0.8 W at 105°C ambient

TYPICAL FREQUENCY RESPONSE

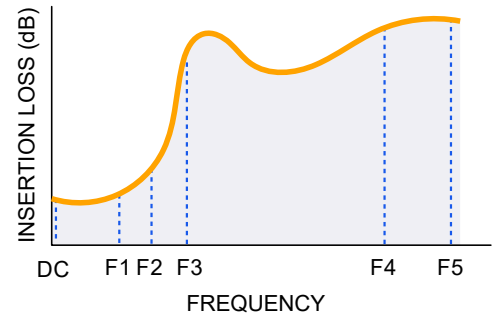



SIMPLIFIED SCHEMATIC AND PAD DESCRIPTION

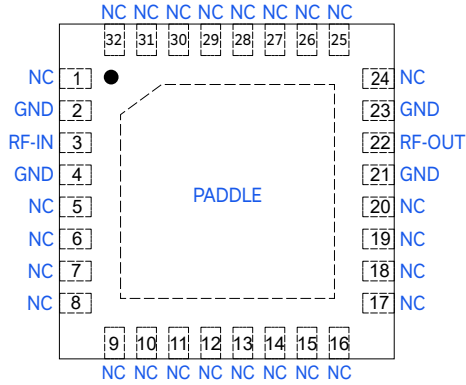
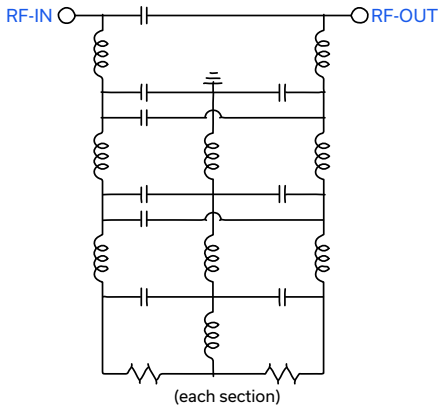

Function	Pad Number	Description
RF-IN	3	RF Input Pad
RF-OUT	22	RF Output Pad
GND	2,4,21,23	Connected to ground
NC (GND Externally)	1,5-20,24-32 & paddle	No internal connection

PRODUCT MARKING

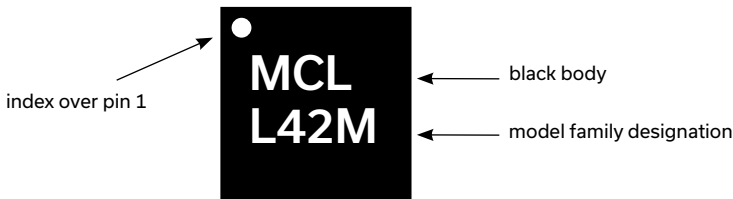

Marking may contain other features or characters for internal lot control



MMIC REFLECTIONLESS

Low Pass Filter

XLF-42M+

50Ω DC to 300 MHz

TYPICAL PERFORMANCE DATA AT +25°C

Frequency (MHz)	Insertion Loss (dB)	VSWR (:1)
10	2.00	1.24
100	2.08	1.26
300	2.79	1.32
350	3.11	1.31
660	20.36	1.19
700	27.07	1.21
1000	27.55	1.14
1500	41.89	1.11
2000	36.20	1.20
2500	27.96	1.24
3000	26.65	1.28
4000	28.44	1.35
5000	31.27	1.49
6000	59.02	1.29
6800	44.75	1.73
7000	45.39	1.80
8000	49.63	2.17
9000	49.94	2.54
10000	47.20	2.89

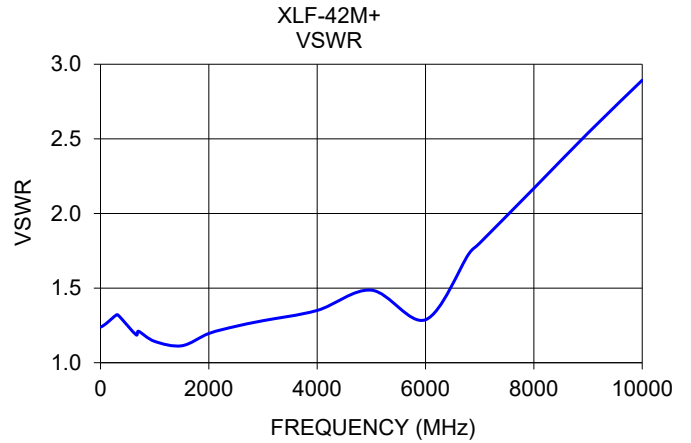
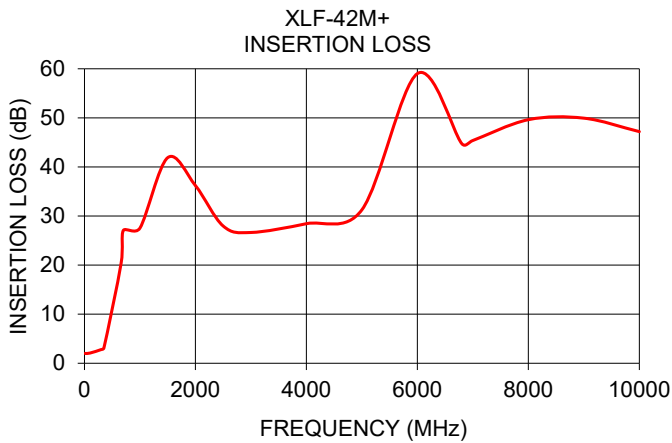



MMIC REFLECTIONLESS

Low Pass Filter

XLF-42M+

50Ω DC to 300 MHz

ADDITIONAL DETAILED TECHNICAL INFORMATION IS AVAILABLE ON OUR DASH BOARD. TO ACCESS [CLICK HERE](#)

Performance Data and Graphs	Data Graphs S-Parameter (S2P Files) Data Set (.zip file)
Case Style	DG1677-2 Plastic package, exposed paddle lead finish: matte-tin
Tape & Reel Standard quantities available on reel	F68 7" reels with 20, 50, 100, 200, 500, 1000 devices 13" reels with 2000, 3000, 4000 devices
Suggested Layout for PCB Design	PL-518
Evaluation Board	TB-944-42M+
Environmental Ratings	ENV82

ESD RATING

Human body model (HBM): Class 1B (pass 500V) in accordance with ANSI/ESD 5.1-2001



REFLECTIONLESS FILTER APPLICATION NOTE

Application Circuit Example: Pairing mixers with reflectionless filters to improve system dynamic range

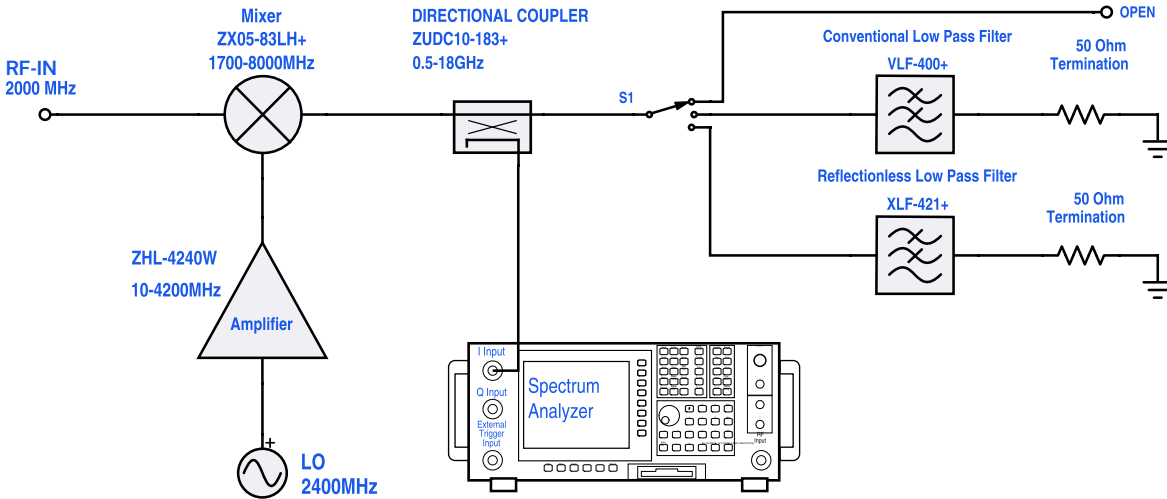

Test block diagram: IF output reflection spectrum with single input frequency

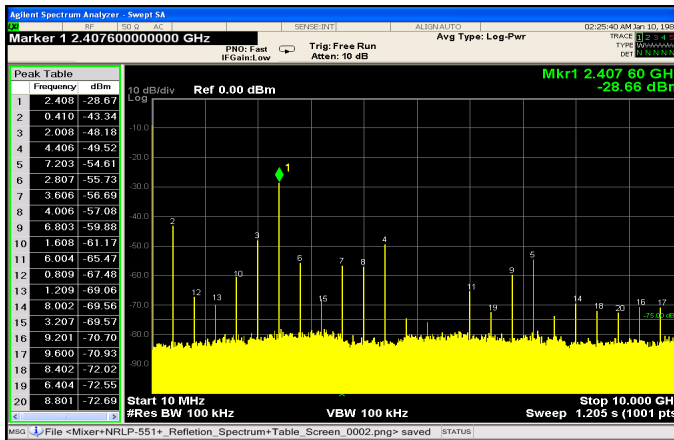

Figure 1. IF output reflection spectrum without filter

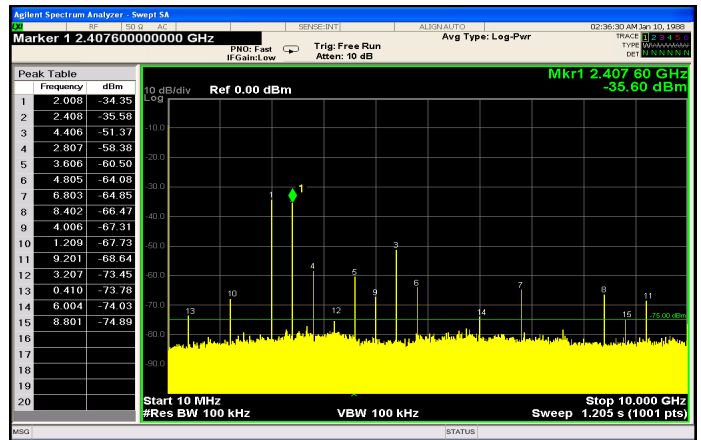

Figure 2. IF output reflection spectrum with conventional filter

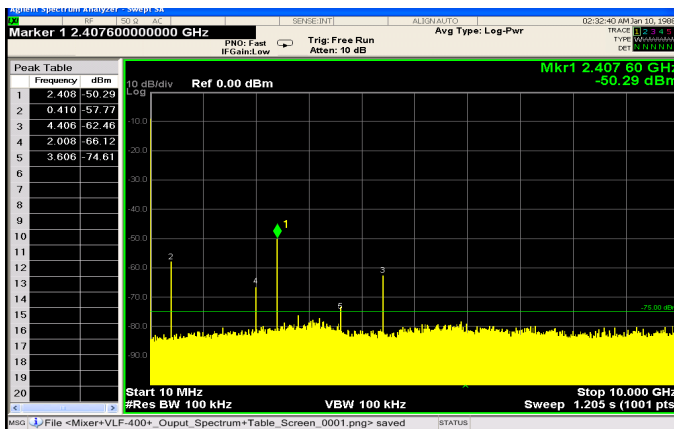

Figure 3. IF output reflection spectrum with reflectionless filter

An application circuit was assembled to measure the IF reflection spectrum at the output of a mixer when the mixer was paired with a conventional filter versus a reflectionless filter.

While the conventional filter reduces the reflections present when the mixer is used alone (no filter), the reflectionless filter virtually eliminates those reflections altogether.

The reflected signal at marker 1 in the figures above exhibits a reduction of more than 20 dB from -28.7 dBm to -50.3 dBm when the reflectionless filter is used as compared to the conventional filter, thus eliminating unwanted spurious mixing products and improving system dynamic range.

For more information, refer to application note [AN-75-007](#)

NOTES

- A. Performance and quality attributes and conditions not expressly stated in this specification document are intended to be excluded and do not form a part of this specification document.
- B. Electrical specifications and performance data contained in this specification document are based on Mini-Circuit's applicable established test performance criteria and measurement instructions.
- C. The parts covered by this specification document are subject to Mini-Circuits standard limited warranty and terms and conditions (collectively, "Standard Terms"); Purchasers of this part are entitled to the rights and benefits contained therein. For a full statement of the standard terms and the exclusive rights and remedies thereunder, please visit Mini-Circuits' website at www.minicircuits.com/MCLStore/terms.jsp

Typical Performance Data

FREQ. (MHz)	INSERTION LOSS			INPUT RETURN LOSS			OUTPUT RETURN LOSS		
	(dB)			(dB)			(dB)		
	@-55°C	@25°C	@+105°C	@-55°C	@+25°C	@+105°C	@-55°C	@+25°C	@+105°C
10	1.58	2.00	2.34	23.32	19.41	17.26	22.96	19.43	17.12
50	1.60	2.02	2.38	22.55	19.38	17.17	22.58	19.29	17.17
100	1.64	2.08	2.47	21.23	18.78	17.11	21.18	18.75	17.04
300	2.14	2.79	3.38	17.73	17.27	16.59	17.91	17.17	16.64
350	2.37	3.11	3.79	17.85	17.65	17.26	18.04	17.57	17.31
500	3.86	5.08	6.21	23.79	23.03	22.02	24.66	23.44	22.42
660	19.50	20.36	20.58	21.35	21.46	20.99	21.49	21.40	20.95
1000	27.58	27.55	27.55	21.01	23.64	26.47	21.21	23.52	27.39
1500	40.57	41.86	42.87	31.57	30.07	29.51	25.58	25.40	25.04
2000	36.21	36.20	36.24	23.61	22.31	20.94	21.74	20.99	19.83
2500	27.67	27.96	28.22	19.60	19.44	19.02	19.39	19.27	19.27
3000	26.28	26.64	26.98	18.18	18.17	17.53	19.06	18.61	18.18
3500	26.77	27.20	27.56	16.78	17.37	17.66	18.17	18.16	19.03
4000	27.99	28.44	28.86	16.12	16.53	16.22	17.72	17.56	18.17
4500	29.35	29.91	30.35	15.76	15.49	15.40	17.26	16.79	17.26
5000	30.66	31.27	31.80	14.73	14.17	14.00	16.30	15.75	16.07
5500	31.09	32.08	33.33	12.67	12.53	12.74	14.64	14.43	14.62
6000	61.29	59.02	53.13	20.37	18.00	17.17	24.23	20.69	19.85
6500	44.07	44.49	44.60	12.18	12.63	13.10	14.56	14.51	14.39
7000	44.61	45.39	46.06	9.94	10.87	11.49	11.73	12.53	13.16
7500	46.66	47.56	48.07	9.27	9.65	9.51	10.93	11.10	10.76
8000	48.93	49.63	50.10	8.36	8.66	8.46	9.88	9.95	9.53
8500	49.74	50.64	51.18	8.54	7.88	6.97	9.28	9.03	8.35
9000	49.42	49.94	50.52	7.76	7.23	6.61	8.83	8.28	7.57
9500	48.05	48.54	48.92	6.59	6.70	6.31	7.36	7.66	7.80
10000	46.64	47.20	47.47	6.13	6.26	6.39	6.91	7.13	7.01
10500	45.59	45.58	45.72	5.20	5.87	6.99	5.72	6.61	7.83
11000	44.48	44.42	44.58	4.70	5.53	6.88	5.38	6.11	6.97
11500	43.01	43.35	43.42	4.99	5.24	6.88	5.22	5.65	6.94
12000	42.94	42.61	43.11	4.49	4.99	5.99	4.60	5.18	6.26
12500	41.42	42.21	42.79	5.09	4.68	5.24	4.67	4.75	5.19
13000	40.50	40.94	41.36	3.64	4.36	4.75	4.10	4.35	5.00
13500	39.47	39.53	40.96	3.88	4.07	4.44	3.75	4.03	4.23
14000	37.59	37.71	38.16	2.85	3.85	4.06	2.91	3.78	4.44
14500	35.12	35.24	35.78	3.39	3.69	4.30	3.27	3.61	4.21
15000	32.46	32.20	32.50	2.09	3.61	4.08	2.38	3.50	4.17
15500	27.84	28.03	28.40	3.53	3.60	3.86	2.95	3.49	4.19
16000	23.38	22.57	22.62	2.15	3.67	4.47	2.32	3.58	4.79
16500	14.32	13.57	13.73	3.50	4.52	4.64	3.69	4.47	4.81
17000	11.00	12.86	14.14	4.35	5.95	6.71	5.96	6.36	7.65
17500	18.15	20.11	21.63	4.43	4.41	4.03	5.23	4.70	4.65
18000	22.61	23.80	24.69	3.75	4.17	5.33	3.72	4.52	6.04
18500	23.92	26.19	28.29	6.12	4.01	3.30	3.87	4.36	3.30
19000	26.96	28.00	29.24	2.93	3.80	5.15	4.02	4.11	5.41
19500	29.21	29.58	30.93	2.55	3.56	3.67	2.32	3.79	4.86
20000	31.19	31.20	32.07	2.16	3.51	5.17	2.17	3.63	6.03
20500	32.51	32.57	33.10	1.70	3.60	4.98	2.17	3.65	5.10
21000	32.39	33.78	34.61	2.68	3.75	6.93	3.26	3.65	5.63
21500	33.55	35.27	36.60	2.84	4.11	4.97	2.97	3.91	4.76
22000	34.64	36.23	37.15	4.30	4.43	5.98	3.82	4.16	5.64
22500	35.49	36.69	38.15	5.00	4.58	4.75	3.71	4.24	4.73
23000	34.80	36.73	37.66	4.74	4.65	5.37	3.77	4.23	5.19
23500	34.88	36.31	38.42	3.81	4.65	4.85	4.08	4.13	4.72
24000	34.64	35.49	37.07	3.67	4.57	4.92	2.69	3.95	4.18
24500	34.73	34.23	35.55	2.29	4.45	4.32	2.92	3.73	4.77
25000	33.10	32.79	33.67	2.59	4.22	5.37	2.27	3.50	4.17
25500	31.75	30.71	31.92	2.37	3.93	5.16	1.93	3.30	4.79
26000	29.37	28.58	29.54	1.97	3.57	4.82	1.22	3.05	4.16
26500	22.93	21.82	22.10	3.34	3.76	5.37	2.01	3.02	5.27



Typical Performance Curves

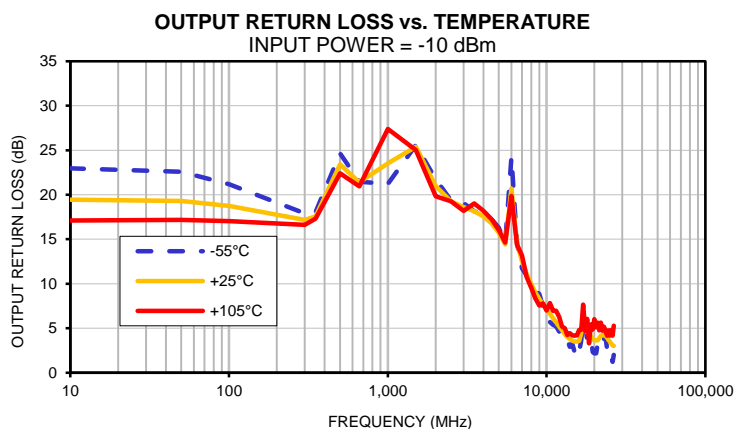
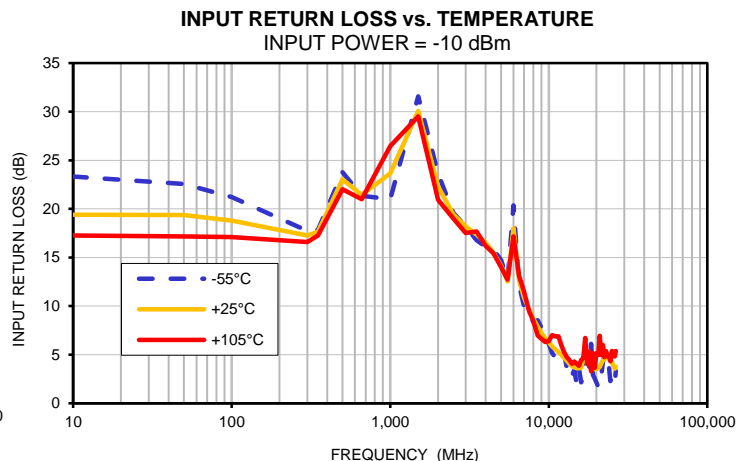
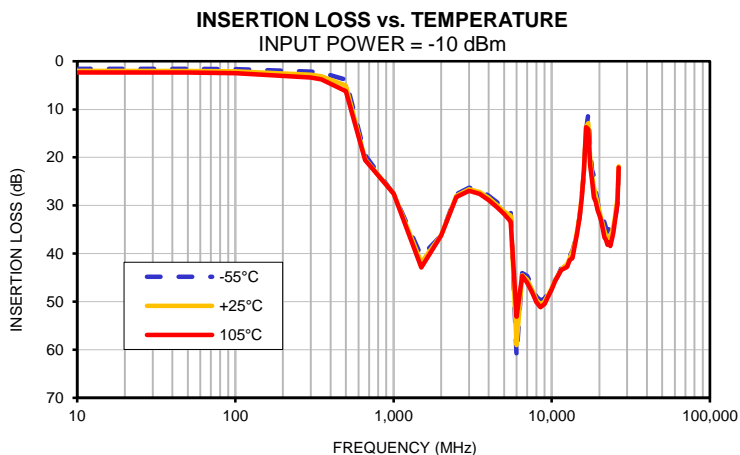

Outline Dimensions

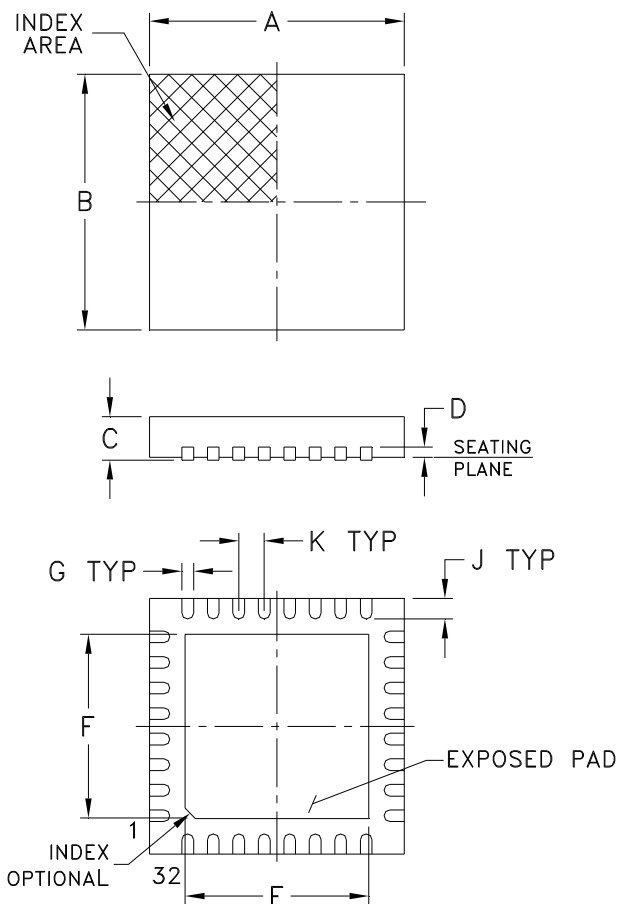

PCB Land Pattern

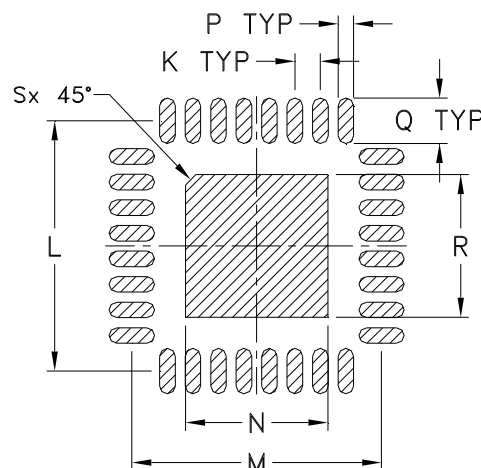

Suggested Layout,
Tolerance to be within $\pm .002$

CASE #	A	B	C MAX	C MIN	D	E	F	G	H	J
DG1677-2	.197 (5.00)	.197 (5.00)	.039 (1.00)	.031 (0.80)	.008 (0.20)	.142 (3.60)	.142 (3.60)	.009 (0.23)	-	.016 (0.40)
CASE #	K	L	M	N	P	Q	R	S	WT. GRAM	
DG1677-2	.020 (0.50)	.193 (4.90)	.193 (4.90)	.110 (2.79)	.012 (0.30)	.035 (0.89)	.110 (2.79)	.008 (0.20)	.05	

Dimensions are in inches (mm). Tolerances: 2 Pl. $\pm .01$; 3 Pl. $\pm .005$

Notes:

- Case material: Plastic.
- Termination finish:

For RoHS Case Styles: Tin-Silver alloy plate over Nickel barrier transitioning to Matte-Tin.
All models, (+) suffix. See Data sheet.

For RoHS-5 Case Styles: Tin-Lead plate. All models, no (+) suffix.

Tape & Reel Packaging TR-F68

DEVICE ORIENTATION IN T&R

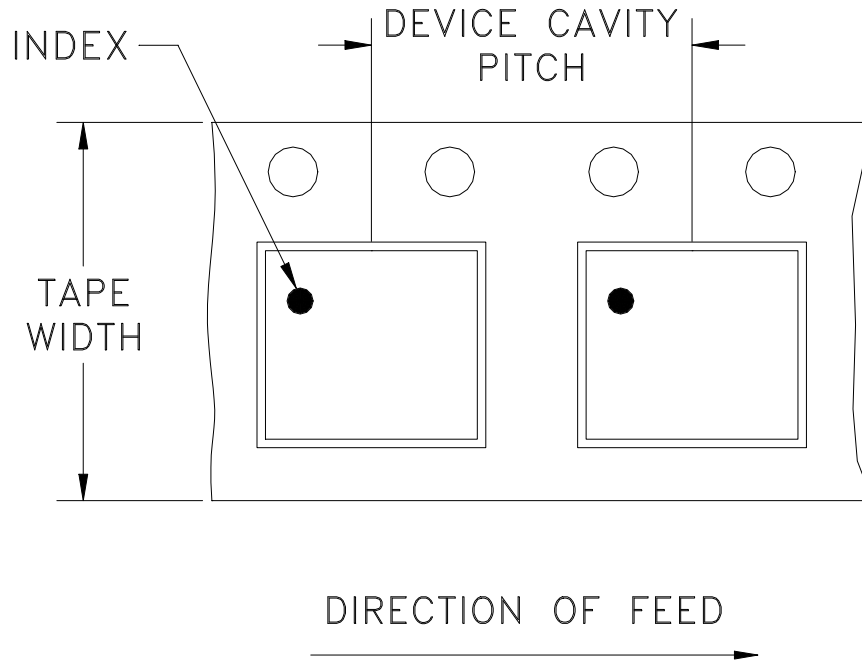

Tape Width, mm	Device Cavity Pitch, mm	Reel Size, inches	Devices per Reel see note	
12	8	7	Small quantity standard	20
				50
				100
				200
				500
		7	Standard	1000
		13	Standard	2000
				3000
				4000

Mini-Circuits carrier tape materials provide protection from ESD (Electro-Static Discharge) during handling and transportation. Tapes are static dissipative and comply with industry standards EIA-481/EIA-541.

Go to: www.minicircuits.com/pages/pdfs/tape.pdf



INTERNET <http://www.minicircuits.com>

P.O. Box 350166, Brooklyn, New York 11235-0003 (718) 934-4500 Fax (718) 332-4661

Distribution Centers NORTH AMERICA 800-654-7949 • 417-335-5935 • Fax 417-335-5945 • EUROPE 44-1252-832600 • Fax 44-1252-837010

Mini-Circuits ISO 9001 & ISO 14001 Certified

THIRD ANGLE PROJECTION

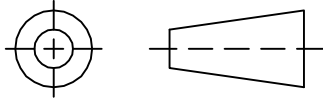

REVISIONS

REV	ECN No.	DESCRIPTION	DATE	DR	AUTH
OR	M162495	NEW RELEASE	06/15/17	GF	RS

SUGGESTED MOUNTING CONFIGURATION FOR
DG1677-2 CASE STYLE, "32FL01" PIN CONNECTION

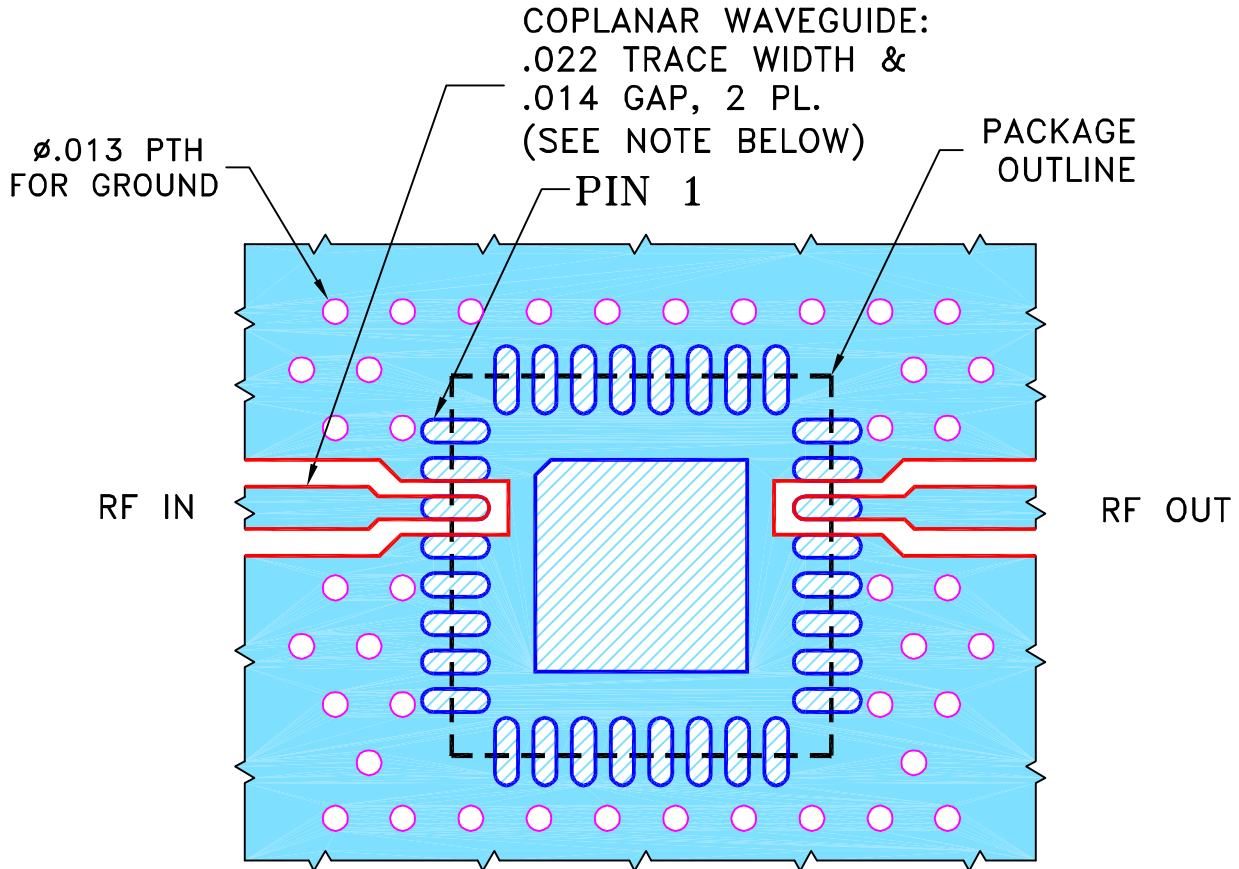

NOTES:

- TRACE WIDTH & GAP ARE SHOWN FOR ROGERS RO4350B WITH DIELECTRIC THICKNESS .010" ± .001"; COPPER: 1/2 OZ. EACH SIDE. FOR OTHER MATERIALS TRACE WIDTH MAY NEED TO BE MODIFIED.
- BOTTOM SIDE OF THE PCB IS CONTINUOUS GROUND PLANE.

- DENOTES PCB COPPER LAYOUT WITH SMOBC (SOLDER MASK OVER BARE COPPER)
- DENOTES COPPER LAND PATTERN FREE OF SOLDER MASK

UNLESS OTHERWISE SPECIFIED	INITIALS	DATE
DRAWN	GF	06/14/17
CHECKED	IL	06/15/17
APPROVED	RS	06/15/17

Mini-Circuits® 13 Neptune Avenue
Brooklyn NY 11235

PL, 32FL01, DG1677-2, TB-944+

THIS DOCUMENT AND ITS CONTENTS ARE THE PROPERTY OF MINI-CIRCUITS. EXCEPT FOR USE EXPRESSLY GRANTED, IN WRITING, TO ITS VENDORS, VENDEE AND THE UNITED STATES GOVERNMENT, MINI-CIRCUITS RESERVES ALL PROPRIETARY DESIGN, USE, MANUFACTURING AND REPRODUCTION RIGHTS THERETO. THESE CONTENTS SHALL NOT BE USED, DUPLICATED OR DISCLOSED TO ANY OUTSIDE PARTY, IN WHOLE OR IN PART, WITHOUT WRITTEN PERMISSION OF MINI-CIRCUITS.

SIZE A	CODE IDENT 15542	DRAWING NO: 98-PL-518	REV: OR
FILE: 98PL518	SCALE: 10:1	SHEET: 1 OF 1	

Evaluation Board and Circuit

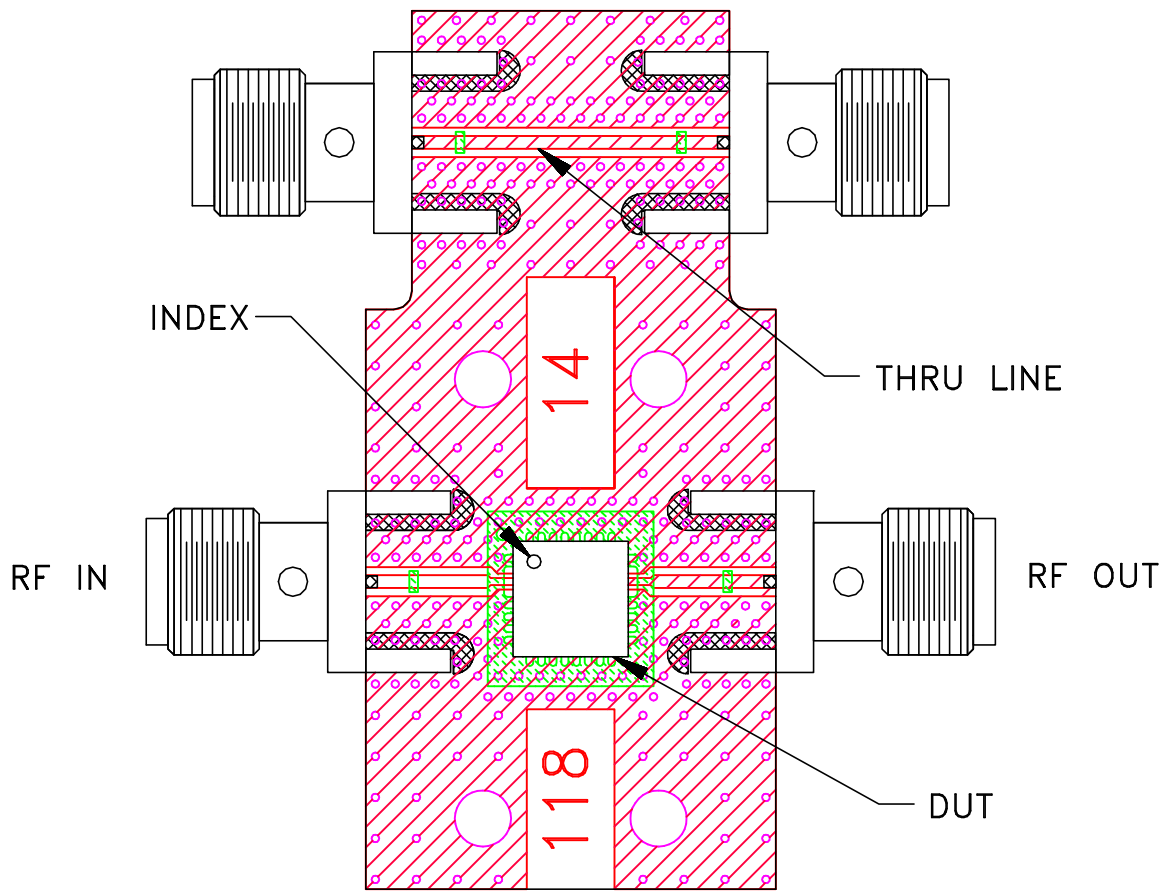

TB-944-42M+

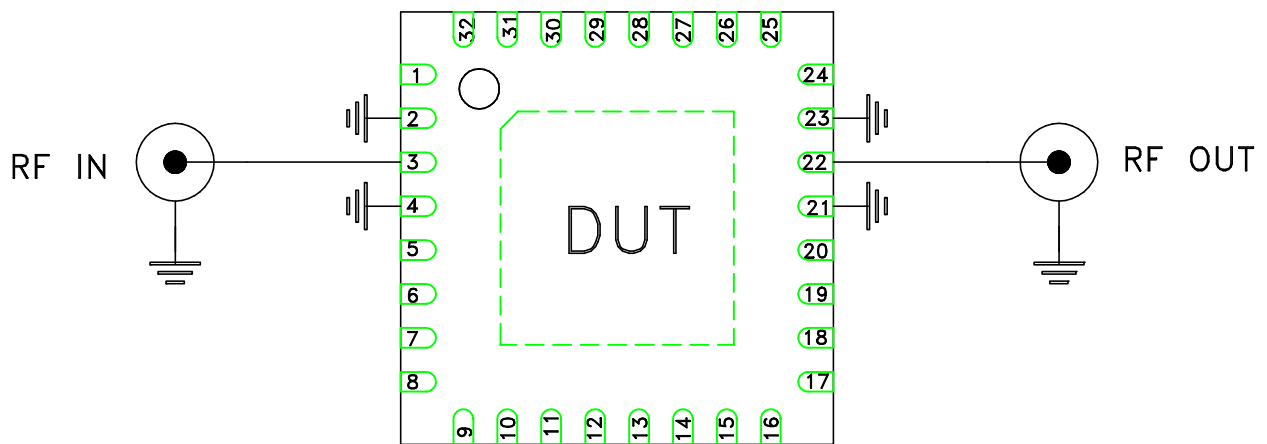

PINS 1,5-8,9-20,24-32 - NOT CONNECTED.

Schematic Diagram

Notes:

1. 50 Ohm SMA Female connectors.
2. PCB Material: R04350 or equivalent,
Dielectric Constant=3.5, Thickness=.010 inch.

 **Mini-Circuits®**



All Mini-Circuits products are manufactured under exacting quality assurance and control standards, and are capable of meeting published specifications after being subjected to any or all of the following physical and environmental test.

Specification	Test/Inspection Condition	Reference/Spec
Operating Temperature	-55° to 105°C Ambient Environment	Individual Model Data Sheet
Storage Temperature	-65° to 150° C Ambient Environment	Individual Model Data Sheet
Autoclave	15 psig, 100% RH, 121°C, 96 hours	JESD22-A102-C, Condition C
Temperature Cycling	-65° to 150°C, 100 cycles	JESD22-A104
Temperature Humidity	85°C/ 85% RH, 168 hours	JESD22-113
Solder Reflow Heat	Sn-Pb Eutetic Process: 240°C peak Pb-Free Process: 260°C peak	J-STD-020, Table 4-1, 4-2 and 5-2; Figure 5-1
Moisture Sensitivity: Level 1	Bake at 125°C for 24 hours Soak at 85°C/85% RH for 168 hours, Reflow 3 cycles at 240°C peak (Non-RoHS) or 260°C (RoHS)	J-STD-020C
Solderability	10X magnification, 95% coverage	JESD22-B102, Method 1: Dip and Look Test
Marking Resistance to Solvents	Isopropyl alcohol + mineral spirits at 25°C; terpene defluxer at 25°C; distilled water + proylene glycol monomethyl ether + monoethanolamine at 63°C to 70°C	MIL-STD-202, Method 215