



MMIC REFLECTIONLESS

Low Pass Filter

XLF-14+

50Ω DC to 10000 MHz

THE BIG DEAL

- Match to 50Ω in the stop band, eliminates undesired reflections
- Cascadable
- Excellent Power handling
- Temperature sData, up to +105°C
- Small size, 3 x 3 mm
- Protected by US Patent No. 8,392,495

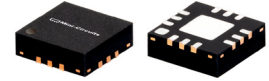

Generic photo used for illustration purposes only

CASE STYLE: DQ1225

+RoHS Compliant

The +Suffix identifies RoHS Compliance. See our website for methodologies and qualifications

APPLICATIONS

- Harmonics Rejection
- Satellite
- Radar
- Military & Space

PRODUCT OVERVIEW

Mini-Circuits' XLF-14+ reflectionless filter employs a novel filter topology which absorbs and terminates stop band signals internally rather than reflecting them back to the source. This new capability enables unique applications for filter circuits beyond those suited to traditional approaches. Traditional filters are reflective in the stop band, sending signals back to the source at 100% of the power level. These reflections interact with neighboring components and often result in inter-modulation and other interferences. Reflectionless filters eliminate stop band reflections, allowing them to be paired with sensitive devices and used in applications that otherwise require circuits such as isolation amplifiers or attenuators.

KEY FEATURES

Features	Advantages
Reflectionless Technology	Reflectionless filters absorb unwanted signals, preventing reflections back to the source. This reduces generation of additional unwanted signals without the need for extra components like attenuators, improving system dynamic range and saving board space.
50Ω Match in Stopband	Reflectionless filters maintain good impedance matching in the stopband, allowing for integration with high gain, wideband amplifiers without the risk of creating out-of-band instabilities.
Excellent RF Performance Repeatability	Fabricated on a GaAs process, X-series filters are inherently repeaData for large-volume production.
Excellent Stability over temperature	With ±0.3 dB variation over temperature, is ideal for use in wide temperature range applications without the need for additional temperature compensation.
Excellent Power Handling in a Compact Package	High power handling extends the usability of these filters to the transmit path for inter-stage filtering.

REV B
ECO-020691
XLF-14+
MCL NY
240117





ELECTRICAL SPECIFICATIONS¹ AT +25°C

Parameter	F#	Frequency (MHz)	Min.	Typ.	Max.	Unit
Passband	DC - F1	DC-10000	—	1.6	2	dB
	F2	13200	—	3.0	—	dB
	DC - F1	DC-10000	—	1.3	—	:1
Stopband	F3 - F4	15800 - 17000	13	16	—	dB
	F4 - F5	17000 - 24200	18	20	—	dB
	F3 - F4	15800 - 17000	—	1.3	—	:1
	F4 - F5	17000 - 24200	—	2.2	—	:1

1. Measured on Mini-Circuits Characterization Test Board TB-844-14+

ABSOLUTE MAXIMUM RATINGS²

Parameter	Ratings
Operating Temperature	-55°C to +105°C
Storage Temperature	-65°C to +150°C
RF Power Input, Passband (DC-F1) ³	2 W at +25°C
RF Power Input, Stopband (F2-F5) ⁴	50 mW at +25°C

- 2. Permanent damage may occur if any of these limits are exceeded.
- 3. Passband rating derates linearly to 1 W at 105°C ambient
- 4. Stopband rating derates linearly to 25 mW at 105°C ambient

SPECIFICATION DEFINITION

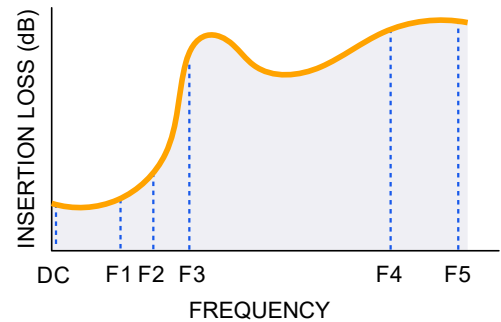



SIMPLIFIED SCHEMATIC AND PAD DESCRIPTION

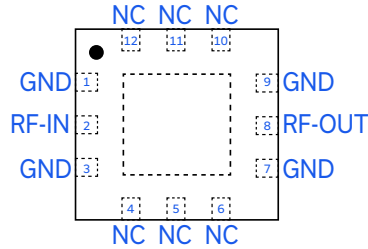
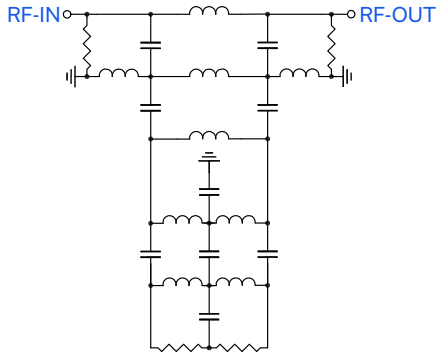

Function	Pad Number	Description
RF-IN	2	RF Input Pad
RF-OUT	8	RF Output Pad
GND	1,3,7,9, Paddle	Connected to ground
NC (GND Externally)	4,5,6,10,11,12	No internal connection

PRODUCT MARKING

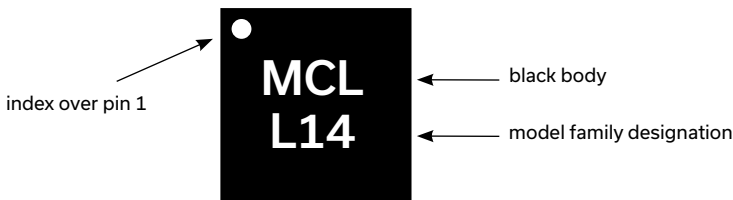

Marking may contain other features or characters for internal lot control



TYPICAL PERFORMANCE DATA AT +25°C

Frequency (MHz)	Insertion Loss (dB)	VSWR (:1)
10	0.41	1.04
50	0.39	1.02
100	0.39	1.02
200	0.39	1.03
400	0.39	1.05
800	0.42	1.10
1600	0.49	1.17
2500	0.55	1.19
3500	0.61	1.21
5000	0.79	1.44
6500	0.94	1.54
8000	1.00	1.39
10000	1.46	1.62
13200	2.97	1.36
15800	15.92	1.25
17000	30.74	1.45
19000	24.05	2.38
21000	20.45	2.34
23000	24.70	1.82
24200	27.43	2.75

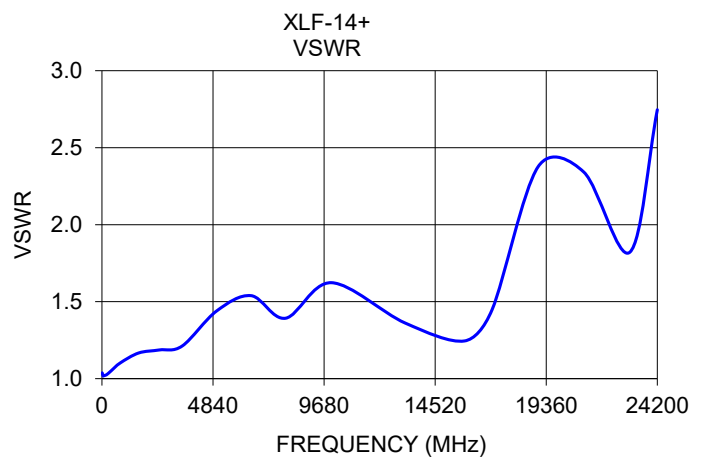
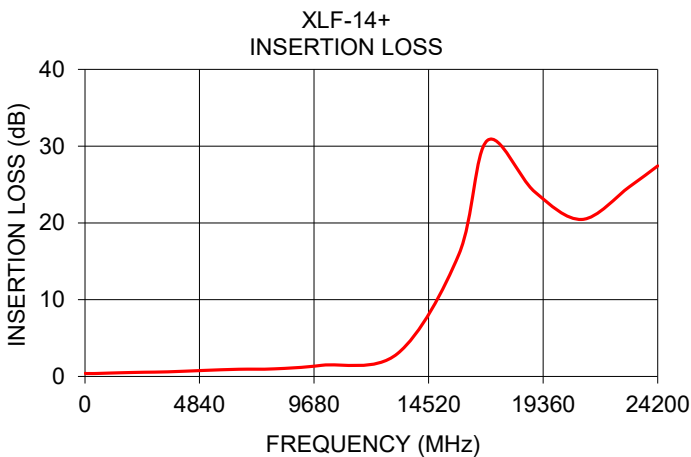



MMIC REFLECTIONLESS

Low Pass Filter

XLF-14+

50Ω DC to 10000 MHz

ADDITIONAL DETAILED TECHNICAL INFORMATION IS AVAILABLE ON OUR DASH BOARD. TO ACCESS [CLICK HERE](#)

Performance Data & Graphs	Data Graphs S-Parameter (S2P Files) Data Set (.zip file)
Case Style	DQ1225 Plastic package, exposed paddle lead finish: matte-tin
Tape & Reel Standard quantities available on reel	F66 7" reels with 20, 50, 100, 200, 500 ,1000, 2000, 3000 devices
Suggested Layout for PCB Design	PL-451
Evaluation Board	TB-844-14+ (without connectors) TB-844-14C+ (with connectors) B20-118-F1+ connector sold separately
Environmental Ratings	ENV82

ESD RATING

Human body model (HBM): Class 1A (250 to <500V) in accordance with ANSI/ESD 5.1-2001

MSL RATING

Moisture Sensitivity: MSL1 in accordance with IPC/JEDEC J-STD-020D



REFLECTIONLESS FILTER APPLICATION NOTE

Application Circuit Example: Pairing mixers with reflectionless filters to improve system dynamic range

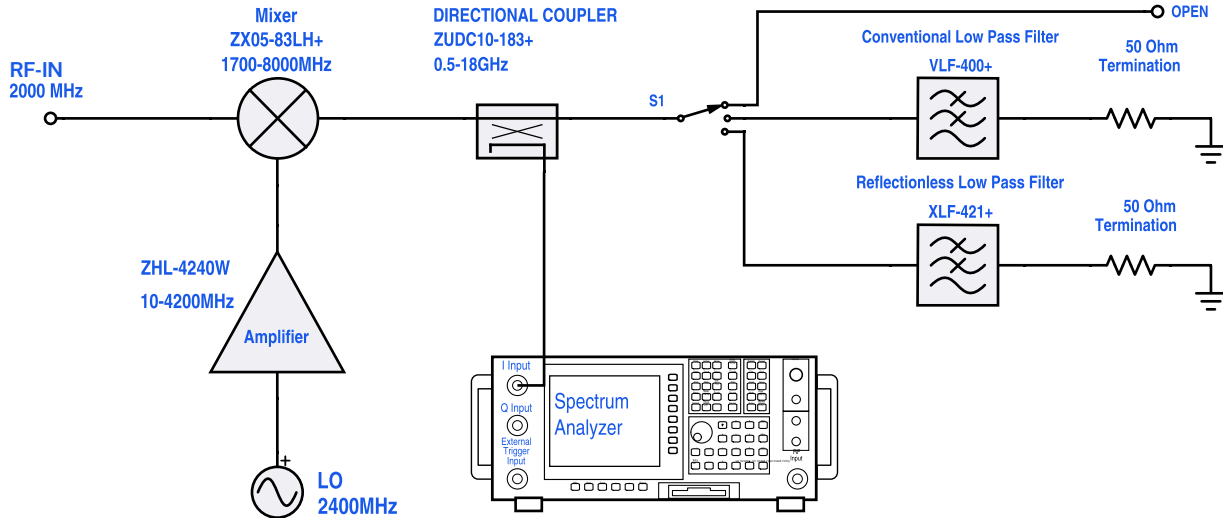

Test block diagram: IF output reflection spectrum with single input frequency

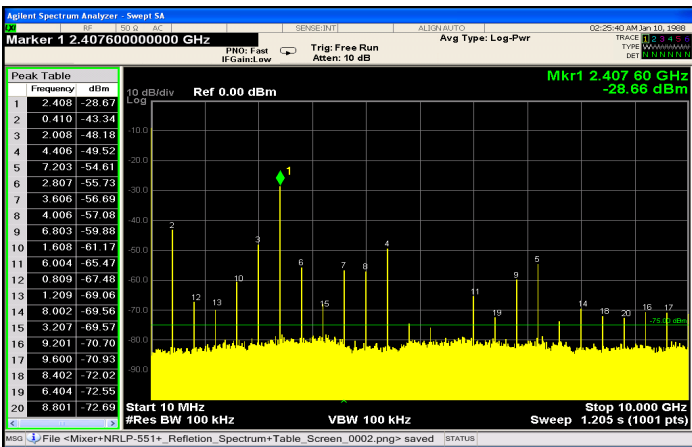

Figure 1. IF output reflection spectrum without filter

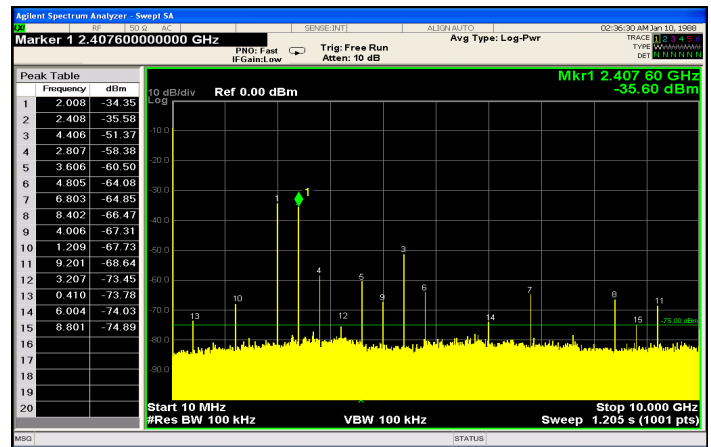
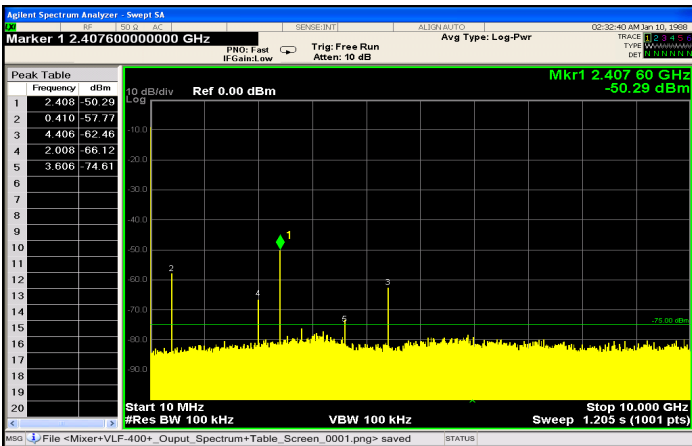

Figure 2. IF output reflection spectrum with conventional filter



An application circuit was assembled to measure the IF reflection spectrum at the output of a mixer when the mixer was paired with a conventional filter versus a reflectionless filter.

While the conventional filter reduces the reflections present when the mixer is used alone (no filter), the reflectionless filter virtually eliminates those reflections altogether.

The reflected signal at marker 1 in the figures above exhibits a reduction of more than 20 dB from -28.7 dBm to -50.3 dBm when the reflectionless filter is used as compared to the conventional filter, thus eliminating unwanted spurious mixing products and improving system dynamic range.

For more information, refer to application note [AN-75-007](#)

- NOTES
- A. Performance and quality attributes and conditions not expressly stated in this specification document are intended to be excluded and do not form a part of this specification document.
 - B. Electrical specifications and performance data contained in this specification document are based on Mini-Circuit's applicable established test performance criteria and measurement instructions.
 - C. The parts covered by this specification document are subject to Mini-Circuits standard limited warranty and terms and conditions (collectively, "Standard Terms"); Purchasers of this part are entitled to the rights and benefits contained therein. For a full statement of the standard terms and the exclusive rights and remedies thereunder, please visit Mini-Circuits' website at www.minicircuits.com/MCLStore/terms.jsp

Typical Performance Data

FREQ. (MHz)	INSERTION LOSS (dB)					GROUP DELAY (nsec)				
	@-55°C	@-40°C	@+25°C	@+85°C	@+105°C	@-55°C	@-40°C	@+25°C	@+85°C	@+105°C
	10	0.38	0.36	0.39	0.43	0.43	0.09	0.09	0.13	0.13
50	0.32	0.34	0.38	0.40	0.40	0.06	0.06	0.06	0.08	0.08
100	0.33	0.34	0.38	0.40	0.41	0.05	0.05	0.05	0.05	0.05
500	0.31	0.33	0.41	0.44	0.45	0.05	0.05	0.04	0.04	0.04
1000	0.31	0.33	0.45	0.48	0.50	0.05	0.05	0.04	0.04	0.04
1500	0.34	0.37	0.49	0.54	0.55	0.04	0.04	0.04	0.04	0.04
2000	0.36	0.38	0.53	0.57	0.59	0.04	0.04	0.04	0.04	0.04
2500	0.37	0.41	0.57	0.60	0.63	0.04	0.04	0.04	0.04	0.04
3000	0.37	0.41	0.58	0.63	0.65	0.04	0.04	0.04	0.04	0.04
3500	0.38	0.43	0.61	0.67	0.70	0.04	0.04	0.04	0.04	0.04
4000	0.41	0.45	0.66	0.73	0.76	0.05	0.04	0.04	0.04	0.04
4500	0.44	0.49	0.72	0.80	0.85	0.05	0.05	0.04	0.04	0.04
5000	0.49	0.54	0.79	0.89	0.94	0.05	0.04	0.04	0.04	0.04
5500	0.56	0.61	0.87	0.97	1.03	0.05	0.04	0.04	0.04	0.04
6000	0.62	0.67	0.92	1.03	1.08	0.05	0.04	0.04	0.04	0.04
6500	0.65	0.71	0.96	1.05	1.10	0.04	0.04	0.04	0.04	0.04
7000	0.63	0.69	0.97	1.08	1.13	0.05	0.05	0.04	0.04	0.04
7500	0.59	0.66	0.98	1.12	1.18	0.05	0.05	0.04	0.04	0.04
8000	0.57	0.65	1.00	1.17	1.24	0.05	0.05	0.05	0.05	0.04
8500	0.60	0.68	1.06	1.25	1.33	0.06	0.06	0.05	0.05	0.05
9000	0.68	0.76	1.14	1.34	1.43	0.06	0.06	0.05	0.05	0.05
9500	0.82	0.90	1.29	1.48	1.57	0.06	0.06	0.05	0.05	0.05
10000	0.98	1.06	1.43	1.63	1.72	0.06	0.06	0.05	0.05	0.05
10500	1.13	1.23	1.62	1.84	1.92	0.06	0.06	0.05	0.06	0.06
11000	1.21	1.32	1.80	2.06	2.16	0.06	0.06	0.06	0.06	0.06
11500	1.27	1.39	1.95	2.27	2.39	0.07	0.07	0.06	0.06	0.06
12000	1.40	1.52	2.11	2.47	2.61	0.08	0.08	0.07	0.07	0.07
12500	1.62	1.75	2.34	2.73	2.88	0.09	0.09	0.08	0.08	0.08
13000	1.94	2.08	2.70	3.14	3.31	0.10	0.10	0.09	0.10	0.10
13200	2.11	2.26	2.91	3.37	3.54	0.10	0.11	0.10	0.10	0.11
13500	2.44	2.60	3.31	3.83	4.03	0.12	0.12	0.11	0.11	0.11
14000	3.26	3.47	4.35	5.01	5.26	0.13	0.13	0.13	0.13	0.13
14500	4.73	4.98	6.13	7.00	7.29	0.15	0.15	0.14	0.14	0.14
15000	7.09	7.42	8.84	9.93	10.33	0.16	0.16	0.15	0.14	0.14
15500	10.69	11.05	12.68	13.96	14.42	0.16	0.16	0.14	0.14	0.13
15800	13.48	13.89	15.60	17.00	17.46	0.15	0.15	0.13	0.13	0.12
16000	15.60	16.03	17.82	19.27	19.76	0.14	0.14	0.13	0.11	0.11
16500	21.86	22.37	24.25	25.66	26.12	0.09	0.09	0.06	0.05	0.05
17000	28.39	28.68	29.78	30.43	30.56	-0.02	-0.02	0.02	0.04	0.07
17500	30.16	30.02	30.35	30.55	30.89	0.11	0.11	0.13	0.16	0.17
18000	28.20	28.32	28.39	28.42	28.50	0.17	0.12	0.15	0.17	0.17
18500	25.69	25.73	26.03	26.10	26.17	0.15	0.15	0.11	0.13	0.12
19000	23.46	23.48	24.14	24.33	24.43	0.12	0.13	0.10	0.09	0.10
19500	21.79	21.89	22.75	23.05	23.26	0.12	0.11	0.08	0.08	0.06
20000	20.84	20.88	21.52	21.95	22.20	0.09	0.09	0.07	0.07	0.07
20500	20.25	20.31	20.65	21.02	21.27	0.09	0.10	0.09	0.08	0.08
21000	19.80	19.89	20.06	20.48	20.71	0.10	0.09	0.10	0.10	0.09
21500	19.68	19.77	20.03	20.47	20.70	0.11	0.11	0.10	0.12	0.11
22000	19.89	20.07	20.67	21.29	21.58	0.12	0.12	0.12	0.14	0.14
22500	20.75	21.00	22.06	23.01	23.34	0.15	0.15	0.15	0.14	0.14
23000	22.56	22.87	24.50	25.59	25.98	0.18	0.20	0.19	0.20	0.21
23500	25.25	25.77	27.16	28.36	28.82	0.19	0.21	0.23	0.29	0.26
24000	25.52	25.98	27.53	28.42	28.72	0.25	0.26	0.27	0.27	0.26
24200	25.10	25.51	26.95	27.59	27.79	0.27	0.27	0.24	0.23	0.25
24500	24.08	24.35	25.73	26.32	26.38	0.23	0.23	0.18	0.17	0.16
25000	22.48	22.63	23.49	23.98	24.20	0.15	0.14	0.12	0.11	0.11
25500	21.32	21.36	21.59	22.06	22.32	0.12	0.11	0.09	0.08	0.08
26000	20.40	20.38	20.07	20.33	20.53	0.06	0.06	0.07	0.08	0.07
26500	19.07	19.11	18.77	18.91	19.00	0.06	0.06	0.07	0.07	0.07
27000	17.51	17.65	17.81	17.83	17.84	0.04	0.04	0.08	0.06	0.08
27500	15.61	15.89	17.02	17.34	17.36	0.08	0.06	0.05	0.05	0.05
28000	14.47	14.72	16.30	16.99	17.21	0.10	0.09	0.04	0.03	0.04
28500	14.36	14.48	15.82	16.62	17.00	0.07	0.07	0.04	0.04	0.02
29000	14.80	14.83	15.28	16.14	16.56	0.04	0.05	0.04	0.04	0.04
29500	15.18	15.19	14.90	15.48	15.85	0.03	0.04	0.05	0.03	0.03
30000	15.02	15.10	14.70	14.82	15.00	0.02	0.02	0.04	0.05	0.04
30500	14.41	14.60	14.61	14.42	14.33	0.03	0.03	0.04	0.05	0.06
31000	13.39	13.66	14.62	14.43	14.24	0.04	0.03	0.03	0.04	0.04
31500	12.60	12.90	14.59	14.75	14.64	0.07	0.06	0.03	0.04	0.04
32000	12.23	12.46	14.51	15.09	15.17	0.11	0.10	0.02	0.02	0.02
32500	13.14	13.14	14.36	15.31	15.70	0.04	0.03	0.03	0.01	0.01
33000	13.86	13.83	14.22	15.38	15.95	0.01	0.01	0.02	-0.01	0.00
33500	14.56	14.51	13.78	15.07	15.75	-0.01	-0.01	0.03	0.01	0.00
34000	14.50	14.47	13.46	14.29	14.99	0.00	0.00	0.03	0.04	0.02
34500	14.18	14.24	13.15	13.58	14.10	-0.01	-0.01	0.02	0.01	0.01
35000	13.41	13.50	12.93	12.94	13.16	0.00	0.00	0.01	0.02	0.03



Typical Performance Data

FREQ. (MHz)	INPUT RETURN LOSS					OUTPUT RETURN LOSS				
	(dB)					(dB)				
	@-55°C	@-40°C	@+25°C	@+85°C	@+105°C	@-55°C	@-40°C	@+25°C	@+85°C	@+105°C
10	32.95	33.48	35.08	36.37	36.10	38.07	39.66	42.76	43.59	47.17
50	37.13	37.52	42.12	46.33	48.08	36.73	37.22	39.56	41.01	40.61
100	36.00	36.37	40.34	44.16	46.89	37.58	37.79	39.53	39.14	38.72
500	30.15	29.99	28.97	28.92	28.59	30.29	29.98	29.51	28.91	28.67
1000	24.75	24.62	23.84	23.57	23.51	24.34	24.25	23.42	23.25	23.17
1500	22.14	22.10	21.88	21.54	21.55	21.78	21.79	21.48	21.38	21.34
2000	20.89	20.94	21.23	21.20	21.20	20.55	20.65	21.22	21.16	21.08
2500	21.15	21.20	21.43	21.85	21.91	20.70	20.83	21.54	21.62	21.68
3000	21.55	21.61	21.93	22.22	22.31	21.22	21.30	21.71	22.10	22.20
3500	21.07	21.10	21.51	21.43	21.39	21.08	21.13	21.28	21.42	21.41
4000	19.71	19.72	19.61	19.19	19.06	19.90	19.90	19.72	19.23	19.08
4500	17.79	17.76	17.33	16.82	16.64	17.84	17.82	17.51	16.84	16.64
5000	15.80	15.78	15.43	15.01	14.84	15.77	15.79	15.43	15.08	14.89
5500	14.26	14.25	14.20	13.99	13.92	14.07	14.13	14.25	14.04	13.97
6000	13.07	13.13	13.54	13.72	13.79	12.77	12.91	13.67	13.82	13.88
6500	12.76	12.86	13.68	14.16	14.43	12.43	12.58	13.79	14.28	14.58
7000	13.49	13.58	14.39	14.88	15.11	13.20	13.32	14.39	14.98	15.28
7500	15.01	15.06	15.26	15.48	15.55	14.73	14.78	15.14	15.46	15.57
8000	16.28	16.30	15.98	15.75	15.60	16.17	16.15	15.86	15.60	15.44
8500	16.43	16.43	15.96	15.65	15.47	16.29	16.34	15.83	15.39	15.17
9000	14.97	15.06	15.16	15.10	15.05	14.70	14.85	15.03	14.81	14.65
9500	13.11	13.25	13.86	14.18	14.29	12.71	12.94	13.91	14.14	14.16
10000	11.73	11.85	12.65	13.07	13.30	11.29	11.48	12.79	13.33	13.57
10500	11.18	11.23	11.81	12.13	12.34	10.70	10.82	12.01	12.61	13.00
11000	11.55	11.53	11.54	11.57	11.64	11.27	11.31	11.80	12.08	12.29
11500	12.50	12.46	12.07	11.89	11.84	12.67	12.66	12.31	12.20	12.21
12000	13.07	13.18	13.35	13.37	13.35	13.52	13.67	13.62	13.48	13.38
12500	13.55	13.89	15.39	16.22	16.55	13.91	14.36	15.58	15.73	15.67
13000	14.61	15.12	18.15	20.31	21.35	14.06	14.65	17.94	18.99	19.04
13200	15.53	16.07	19.35	22.04	23.36	13.95	14.55	19.06	21.39	21.68
13500	17.35	17.86	20.76	23.39	24.45	14.81	15.42	20.36	23.98	25.06
14000	21.64	21.80	21.99	23.68	24.16	16.43	16.88	21.68	27.00	29.90
14500	21.59	21.57	20.56	20.94	20.96	20.34	20.53	20.11	19.62	18.85
15000	18.14	18.21	18.11	18.31	18.28	23.36	23.01	16.51	15.64	15.64
15500	16.33	16.43	17.05	17.48	17.56	14.89	15.34	17.83	17.83	17.35
15800	16.34	16.59	17.73	18.38	18.63	12.93	13.45	18.71	22.08	23.23
16000	16.84	17.14	18.63	19.52	19.91	13.28	13.81	19.07	23.86	27.63
16500	18.88	19.40	21.30	22.93	23.66	19.24	19.46	18.75	18.26	17.74
17000	16.14	16.24	16.65	16.86	16.86	17.01	17.17	16.17	14.98	14.31
17500	11.65	11.68	11.85	11.91	11.89	9.80	10.18	13.10	13.86	13.93
18000	8.72	8.76	8.91	8.93	8.92	7.63	7.89	10.51	11.99	12.88
18500	7.05	7.11	7.32	7.35	7.41	7.51	7.63	8.29	8.86	9.23
19000	6.07	6.14	6.44	6.54	6.63	7.84	7.83	7.00	6.93	6.95
19500	5.81	5.93	6.26	6.56	6.69	7.23	7.34	6.33	5.97	5.78
20000	5.99	6.13	6.61	7.01	7.12	5.76	6.05	6.41	6.13	5.86
20500	6.58	6.76	7.46	7.96	8.07	4.99	5.39	7.15	7.23	6.94
21000	7.87	8.06	8.93	9.54	9.67	5.15	5.56	8.83	9.75	9.48
21500	9.68	9.85	10.86	11.58	11.76	5.91	6.37	11.56	14.19	13.77
22000	12.40	12.50	13.27	13.80	13.96	8.40	8.74	14.27	20.74	21.56
22500	14.52	14.47	14.12	14.09	14.13	10.70	10.89	15.86	22.50	25.41
23000	13.04	12.90	12.73	13.13	13.18	10.13	10.30	14.68	20.07	26.08
23500	11.25	11.67	12.14	12.02	12.21	10.40	10.34	11.40	13.25	14.85
24000	10.07	9.97	9.70	10.09	10.40	13.05	12.40	8.89	8.62	8.70
24200	9.05	9.04	8.93	9.45	9.79	13.40	12.74	8.51	7.87	7.78
24500	7.63	7.68	7.83	8.31	8.56	10.88	10.73	7.18	6.38	6.11
25000	5.95	6.05	6.50	6.92	7.04	5.60	5.96	6.34	5.62	5.22
25500	4.87	4.99	5.58	5.87	5.93	3.29	3.66	5.82	5.54	5.18
26000	4.42	4.54	5.09	5.25	5.27	2.17	2.48	5.67	6.49	6.34
26500	4.27	4.38	4.82	4.95	5.02	2.28	2.53	5.56	7.45	8.11
27000	4.35	4.42	4.76	4.85	4.95	2.98	3.17	5.24	7.14	8.34
27500	4.40	4.48	4.74	4.96	5.08	5.38	5.33	4.80	5.20	5.55
28000	4.44	4.53	4.78	5.14	5.23	6.76	6.72	4.48	3.94	3.84
28500	4.09	4.19	4.57	4.90	4.85	4.37	4.72	4.33	3.52	3.25
29000	3.77	3.85	4.29	4.58	4.47	2.30	2.66	4.22	3.71	3.34
29500	3.43	3.52	3.97	4.19	4.07	1.45	1.76	4.35	4.51	4.11
30000	3.16	3.24	3.60	3.80	3.79	1.31	1.56	4.13	5.55	5.55
30500	2.98	3.04	3.32	3.56	3.68	1.61	1.77	3.81	6.13	7.22
31000	2.65	2.73	3.03	3.37	3.60	2.56	2.62	3.37	5.01	6.19
31500	2.36	2.45	2.85	3.29	3.53	3.60	3.55	3.02	3.67	4.16
32000	2.13	2.21	2.61	3.17	3.39	3.50	3.68	2.72	2.70	2.84
32500	1.98	2.06	2.43	2.91	3.01	1.57	1.91	2.61	2.25	2.12
33000	1.97	2.05	2.39	2.79	2.78	0.75	1.05	2.50	2.05	1.80
33500	1.83	1.92	2.28	2.49	2.41	0.30	0.56	2.36	2.11	1.80
34000	1.68	1.78	2.17	2.26	2.20	0.12	0.35	2.35	2.62	2.35
34500	1.46	1.54	2.04	2.06	2.00	0.08	0.26	2.38	3.58	3.54
35000	1.30	1.41	1.96	2.01	2.00	0.33	0.50	2.55	4.50	5.09



Typical Performance Curves

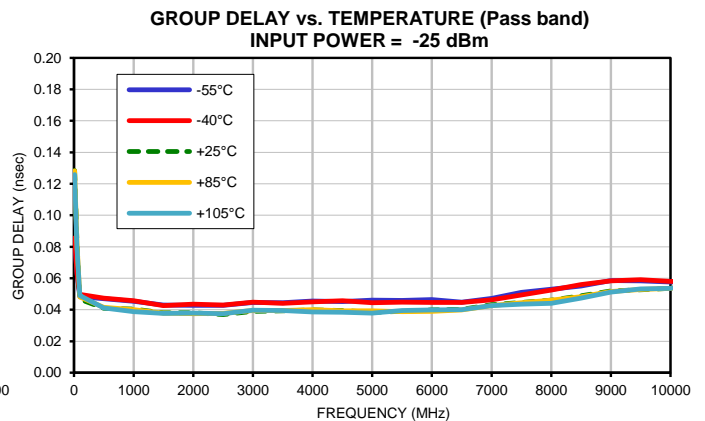
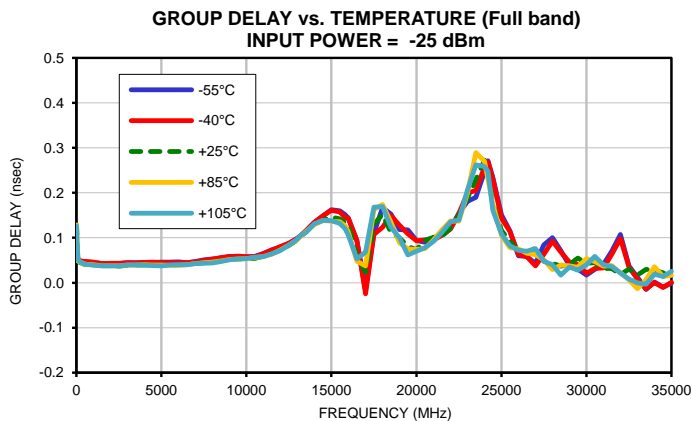
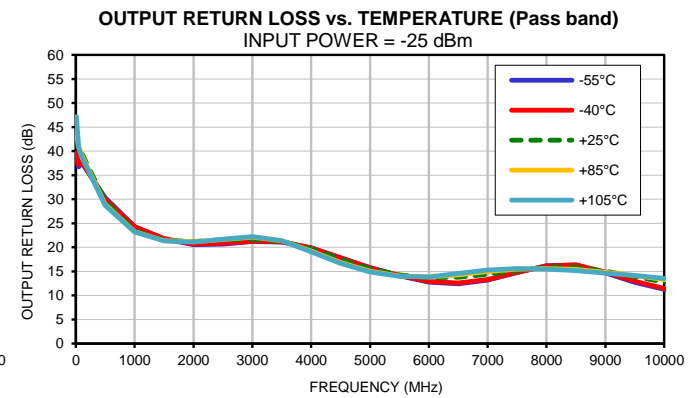
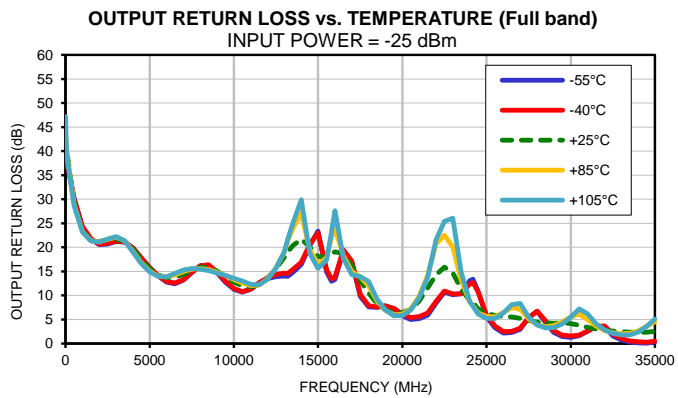
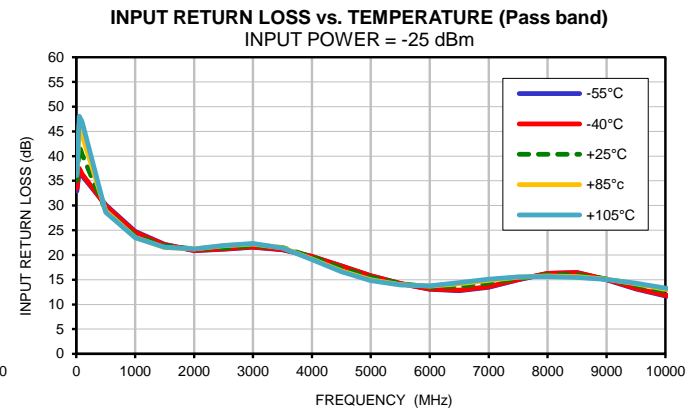
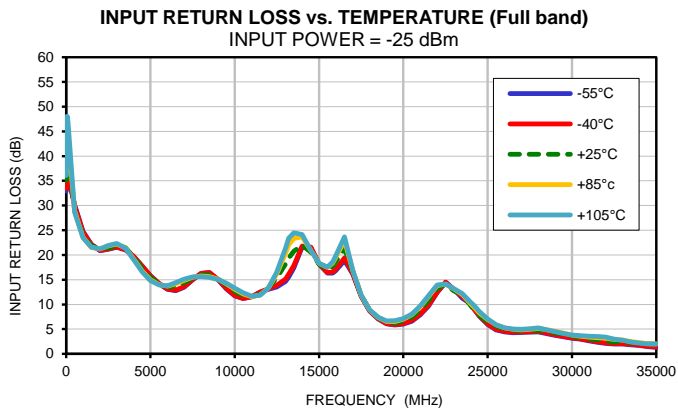
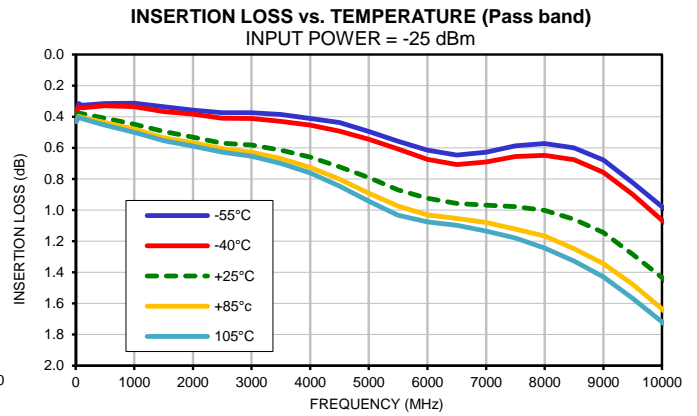
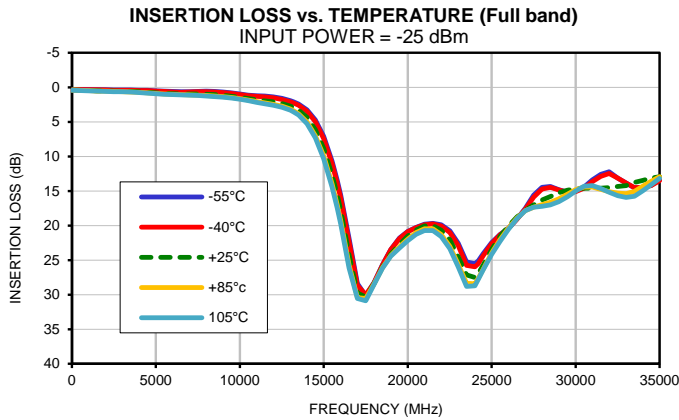

Outline Dimensions

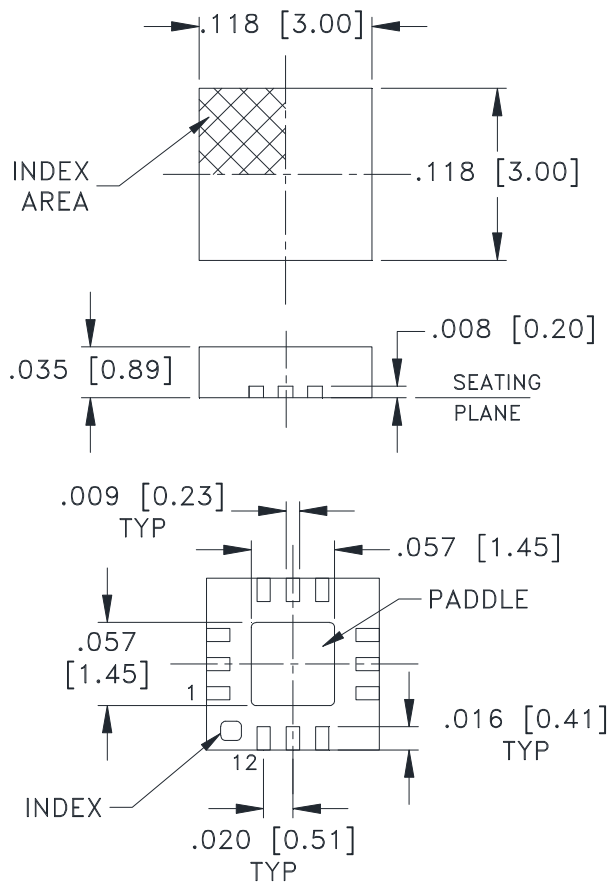

PCB Land Pattern

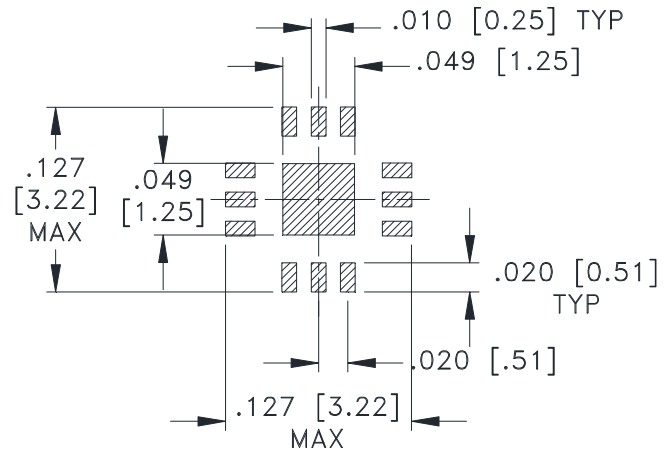

SUGGESTED LAYOUT,
TOLERANCE TO BE WITHIN $\pm .002$

Weight: .02 Grams

Dimensions are in inches (mm). Tolerances: 2Pl. $\pm .01$; 3 Pl. $\pm .004$

Notes:

1. Case material: Plastic.
2. Termination finish:
 - For RoHS Case Styles: Tin-Silver alloy plate over Nickel barrier or Matte-Tin. All models, (+) suffix. See Data sheet.
 - For RoHS-5 Case Styles: Tin-Lead plate. All models, no (+) suffix.

Tape & Reel Packaging TR-F66

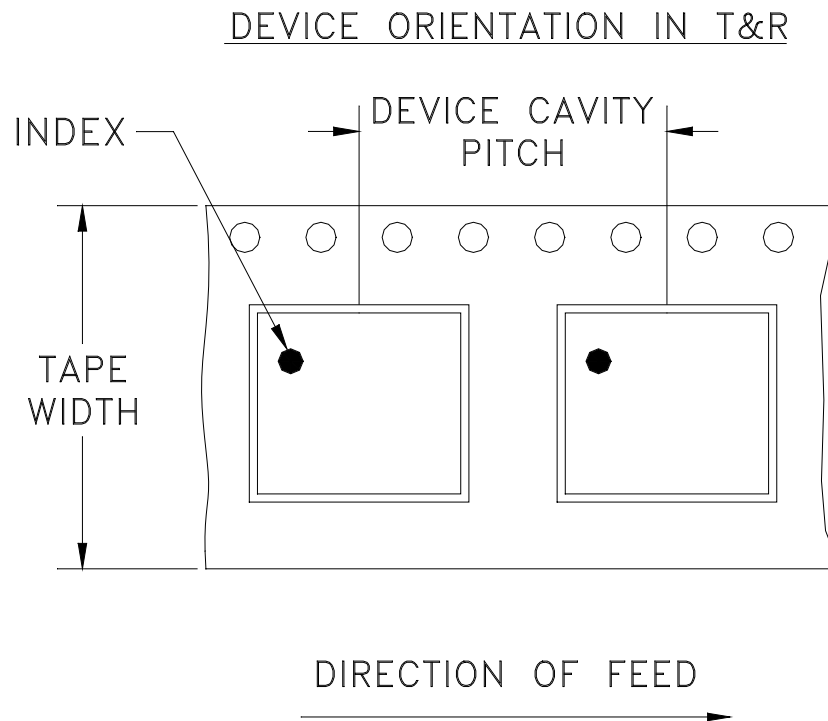

Tape Width, mm	Device Cavity Pitch, mm	Reel Size, inches	Devices per Reel see note	
8	4	7	Small quantity standard	20
				50
				100
				200
				500
		7	Standard	1000, 2000, 3000

Note: Please consult individual model data sheet to determine device per reel availability.

Mini-Circuits carrier tape materials provide protection from ESD (Electro-Static Discharge) during handling and transportation. Tapes are static dissipative and comply with industry standards EIA-481/EIA-541.

Go to: www.minicircuits.com/pages/pdfs/tape.pdf

Mini-Circuits®

INTERNET <http://www.minicircuits.com>

P.O. Box 350166, Brooklyn, New York 11235-0003 (718) 934-4500 Fax (718) 332-4661

Distribution Centers NORTH AMERICA 800-654-7949 • 417-335-5935 • Fax 417-335-5945 • EUROPE 44-1252-832600 • Fax 44-1252-837010

Mini-Circuits ISO 9001 & ISO 14001 Certified

THIRD ANGLE PROJECTION

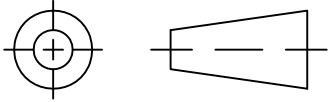

REVISIONS

REV	ECN No.	DESCRIPTION	DATE	DR	AUTH
OR	M152656	NEW RELEASE	09/11/15	ITG	MY

SUGGESTED MOUNTING CONFIGURATION
FOR DQ1225 CASE STYLE, "12FL02" PIN CODE

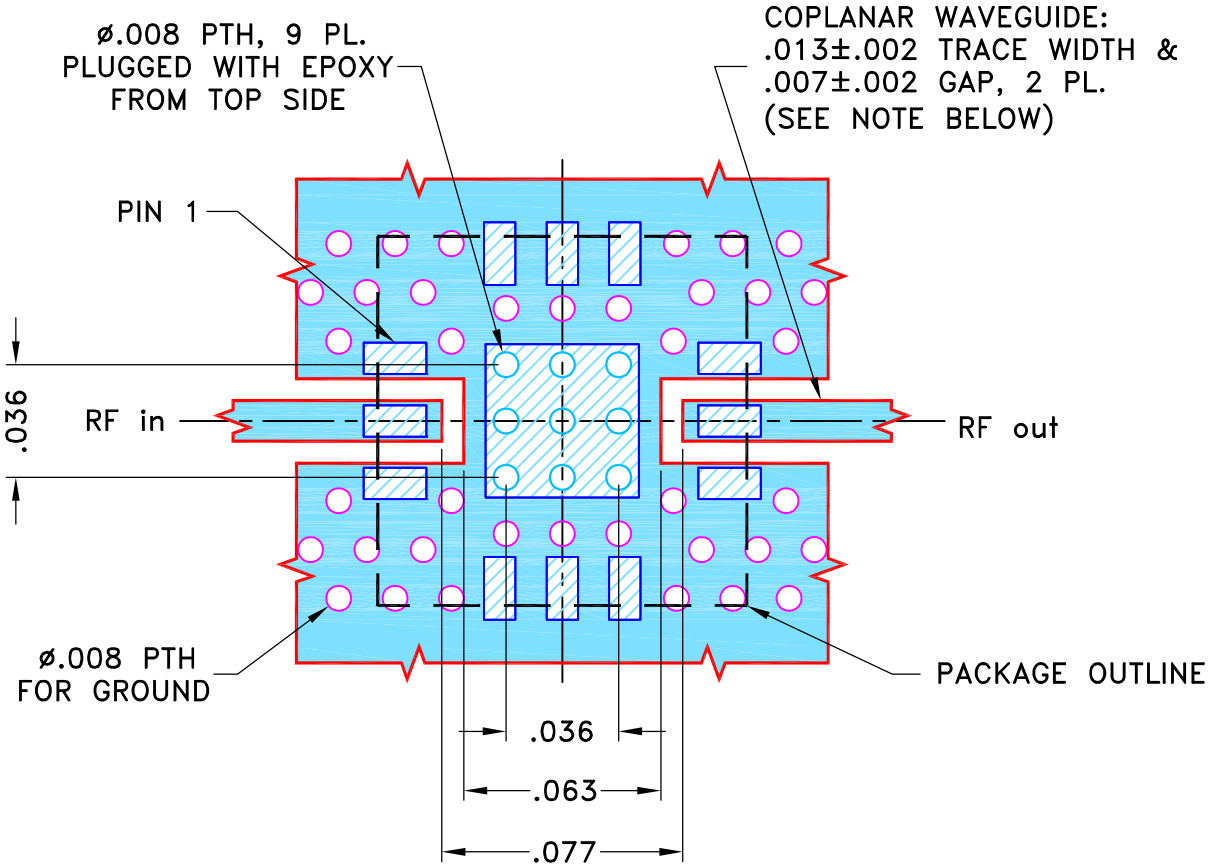

NOTES:

- TRACE WIDTH PARAMETERS ARE SHOWN FOR ROGERS R04350B WITH DIELECTRIC THICKNESS $.0066 \pm .0007$ ". COPPER: 1/2 OZ. EACH SIDE. FOR OTHER MATERIALS TRACE WIDTH AND GAP MAY NEED TO BE MODIFIED.
- BOTTOM SIDE OF THE PCB IS CONTINUOUS GROUND PLANE.

- DENOTES PCB COPPER LAYOUT WITH SMOBC (SOLDER MASK OVER BARE COPPER).
- DENOTES COPPER LAND PATTERN FREE OF SOLDER MASK.

UNLESS OTHERWISE SPECIFIED	INITIALS		DATE
DIMENSIONS ARE IN INCHES TOLERANCES ON: 2 PL DECIMALS ± 3 PL DECIMALS ± .005 ANGLES ± FRACTIONS ±	DRAWN	ITG	09/10/15
	CHECKED	GF	09/11/15
	APPROVED	MY	09/11/15

Mini-Circuits[®] 13 Neptune Avenue
Brooklyn NY 11235

PL, 12FL02, DQ1225, TB-844+

Mini-Circuits[®]
THIS DOCUMENT AND ITS CONTENTS ARE THE PROPERTY OF MINI-CIRCUITS. EXCEPT FOR USE EXPRESSLY GRANTED, IN WRITING, TO ITS VENDORS, VENDEE AND THE UNITED STATES GOVERNMENT, MINI-CIRCUITS RESERVES ALL PROPRIETARY DESIGN, USE, MANUFACTURING AND REPRODUCTION RIGHTS THERETO. THESE CONTENTS SHALL NOT BE USED, DUPLICATED OR DISCLOSED TO ANY OUTSIDE PARTY, IN WHOLE OR IN PART, WITHOUT WRITTEN PERMISSION OF MINI-CIRCUITS.

SIZE A	CODE IDENT 15542	DRAWING NO: 98-PL-451	REV: OR
FILE: 98PL451	SCALE: 16:1	SHEET: 1 OF 1	

Evaluation Board and Circuit

To be used with Mini-Circuits 50 Ohm 2.92 connectors B20-118-F1+.
Connectors are sold separately.

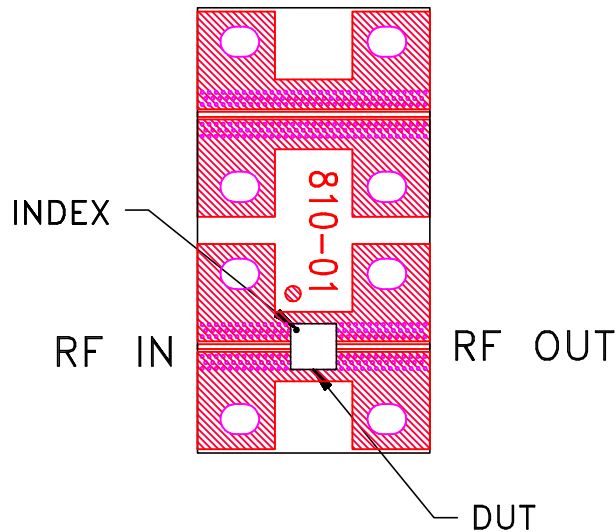

TB-844-14+

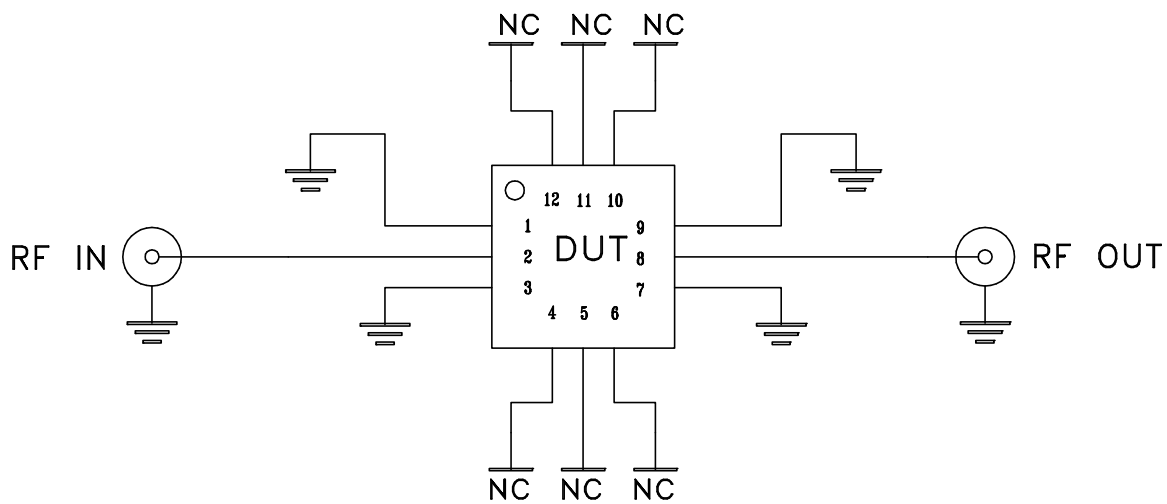

Schematic Diagram

Note:

PCB Material: R04350 or equivalent,
Dielectric Constant=3.5, Thickness=.0066 inch.

 **Mini-Circuits®**

Evaluation Board and Circuit

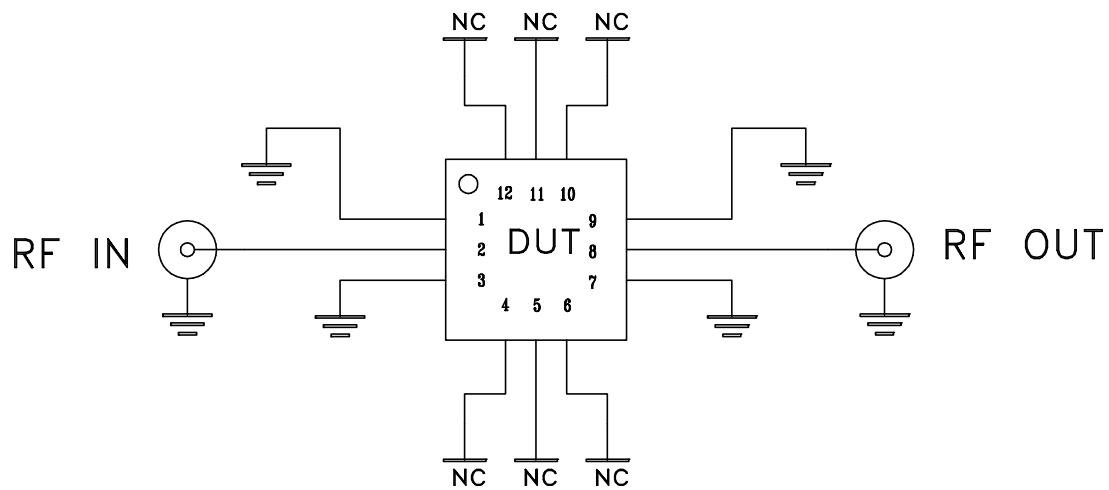
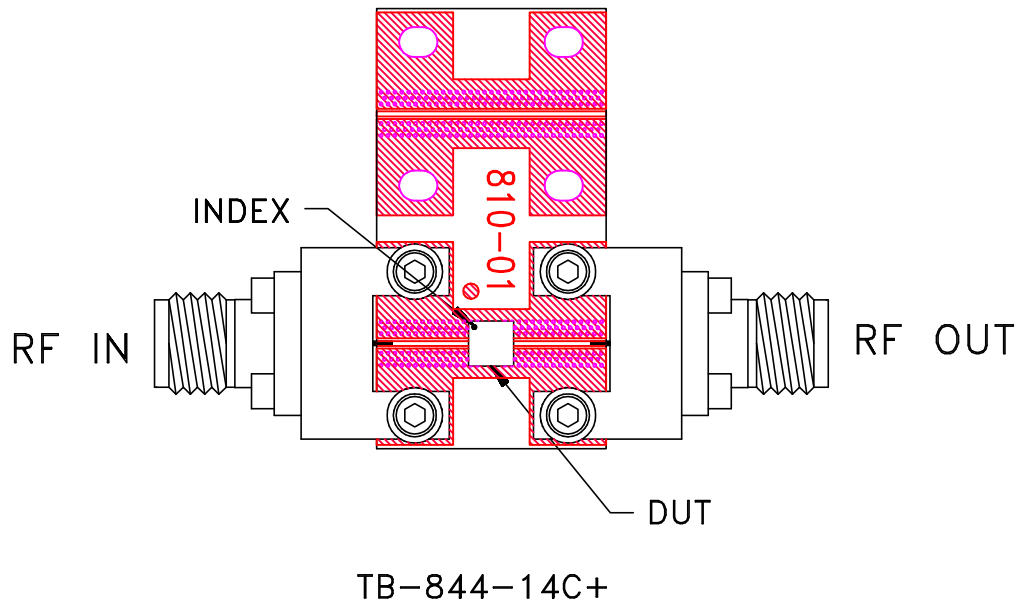

Schematic Diagram

Notes:

1. 50 Ohm 2.92 mm Female connectors.
2. PCB Material: R04350 or equivalent,
Dielectric Constant=3.5, Thickness=.0066 inch.

 **Mini-Circuits®**



All Mini-Circuits products are manufactured under exacting quality assurance and control standards, and are capable of meeting published specifications after being subjected to any or all of the following physical and environmental test.

Specification	Test/Inspection Condition	Reference/Spec
Operating Temperature	-55° to 105°C Ambient Environment	Individual Model Data Sheet
Storage Temperature	-65° to 150° C Ambient Environment	Individual Model Data Sheet
Autoclave	15 psig, 100% RH, 121°C, 96 hours	JESD22-A102-C, Condition C
Temperature Cycling	-65° to 150°C, 100 cycles	JESD22-A104
Temperature Humidity	85°C/ 85% RH, 168 hours	JESD22-113
Solder Reflow Heat	Sn-Pb Eutetic Process: 240°C peak Pb-Free Process: 260°C peak	J-STD-020, Table 4-1, 4-2 and 5-2; Figure 5-1
Moisture Sensitivity: Level 1	Bake at 125°C for 24 hours Soak at 85°C/85% RH for 168 hours, Reflow 3 cycles at 240°C peak (Non-RoHS) or 260°C (RoHS)	J-STD-020C
Solderability	10X magnification, 95% coverage	JESD22-B102, Method 1: Dip and Look Test
Marking Resistance to Solvents	Isopropyl alcohol + mineral spirits at 25°C; terpene defluxer at 25°C; distilled water + proylene glycol monomethyl ether + monoethanolamine at 63°C to 70°C	MIL-STD-202, Method 215