



MMIC REFLECTIONLESS

Low Pass Filter

XLF-133+

Mini-Circuits

50Ω DC to 13100 MHz

THE BIG DEAL

- Match to 50Ω in the stop band, eliminates undesired reflections
- Cascadable
- Excellent Power handling
- Temperature sData, up to +105°C
- Small size, 3 x 3 mm
- Protected by US Patent No. 8,392,495

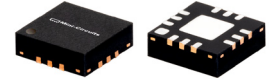

Generic photo used for illustration purposes only

CASE STYLE: DQ1225

+RoHS Compliant

The +Suffix identifies RoHS Compliance. See our website for methodologies and qualifications

APPLICATIONS

- Harmonics Rejection
- Satellite
- Radar
- Military & Space

PRODUCT OVERVIEW

Mini-Circuits' XLF-133+ reflectionless filter employs a novel filter topology which absorbs and terminates stop band signals internally rather than reflecting them back to the source. This new capability enables unique applications for filter circuits beyond those suited to traditional approaches. Traditional filters are reflective in the stop band, sending signals back to the source at 100% of the power level. These reflections interact with neighboring components and often result in inter-modulation and other interferences. Reflectionless filters eliminate stop band reflections, allowing them to be paired with sensitive devices and used in applications that otherwise require circuits such as isolation amplifiers or attenuators.

KEY FEATURES

Features	Advantages
Reflectionless Technology	Reflectionless filters absorb unwanted signals, preventing reflections back to the source. This reduces generation of additional unwanted signals without the need for extra components like attenuators, improving system dynamic range and saving board space.
50Ω Match in Stopband	Reflectionless filters maintain good impedance matching in the stopband, allowing for integration with high gain, wideband amplifiers without the risk of creating out-of-band instabilities.
Excellent RF Performance Repeatability	Fabricated on a GaAs process, X-series filters are inherently repeaData for large-volume production.
Excellent Stability over temperature	With ±0.3 dB variation over temperature, is ideal for use in wide temperature range applications without the need for additional temperature compensation.
Excellent Power Handling in a Compact Package	High power handling extends the usability of these filters to the transmit path for inter-stage filtering.

REV. B
ECO-020691
XLF-133+
MCL NY
240117





ELECTRICAL SPECIFICATIONS¹ AT +25°C

Parameter	F#	Frequency (MHz)	Min.	Typ.	Max.	Unit	
Passband	DC - F1	DC-13100	—	2.0	2.4	dB	
	Frequency Cut-off	F2	15800	—	3.0	dB	
	VSWR	DC - F1	DC-13100	—	1.3	:1	
Stopband	Rejection	F3 - F4	19500 - 20000	13	16	dB	
		F4 - F5	20000 - 30000	18	21	dB	
	VSWR	F3 - F4	19500 - 20000	—	1.5	—	:1
		F4 - F5	20000 - 30000	—	2.7	—	:1

1. Measured on Mini-Circuits Characterization Test Board TB-844-133+

ABSOLUTE MAXIMUM RATINGS²

Parameter	Ratings
Operating Temperature	-55°C to +105°C
Storage Temperature	-65°C to +150°C
RF Power Input, Passband (DC-F1) ³	2 W at +25°C
RF Power Input, Stopband (F2-F5) ⁴	50 mW at +25°C

2. Permanent damage may occur if any of these limits are exceeded.

3. Passband rating derates linearly to 1 W at 105°C ambient

4. Stopband rating derates linearly to 25 mW at 105°C ambient

SPECIFICATION DEFINITION

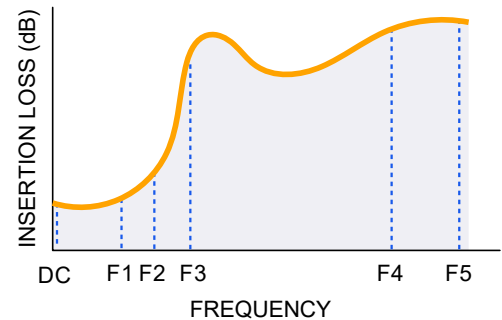



SIMPLIFIED SCHEMATIC AND PAD DESCRIPTION

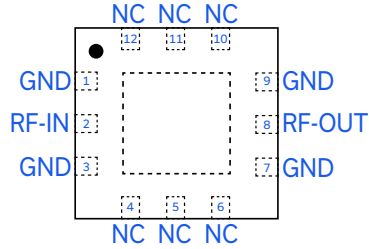
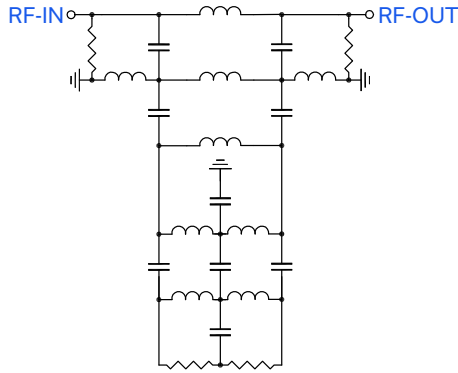

Function	Pad Number	Description
RF-IN	2	RF Input Pad
RF-OUT	8	RF Output Pad
GND	1,3,7,9, Paddle	Connected to ground
NC (GND Externally)	4,5,6,10,11,12	No internal connection

PRODUCT MARKING

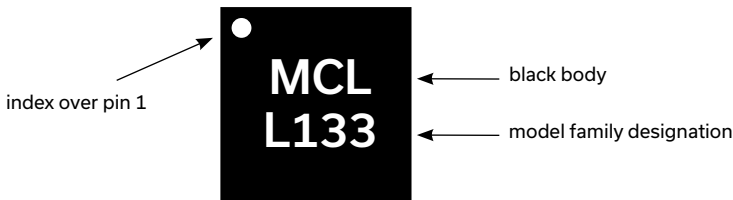

Marking may contain other features or characters for internal lot control



MMIC REFLECTIONLESS

Low Pass Filter

XLF-133+

Mini-Circuits

50Ω DC to 13100 MHz

TYPICAL PERFORMANCE DATA AT +25°C

Frequency (MHz)	Insertion Loss (dB)	VSWR (:1)
10	0.34	1.02
100	0.33	1.02
200	0.36	1.04
400	0.42	1.08
800	0.56	1.14
1600	0.77	1.22
3200	1.07	1.19
5000	1.22	1.16
7000	1.18	1.09
9000	1.25	1.24
11000	1.73	1.81
13100	1.94	1.60
15800	3.15	1.55
17500	6.49	1.69
19500	18.98	1.58
20000	24.37	1.72
22500	30.09	4.80
25000	21.52	2.37
27500	26.48	1.91
30000	24.30	4.05

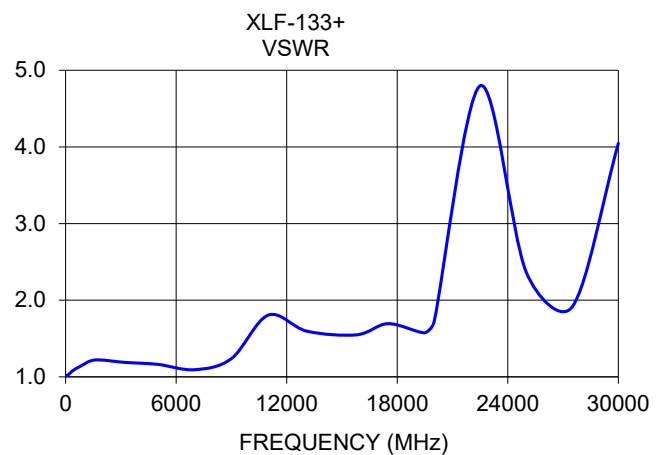
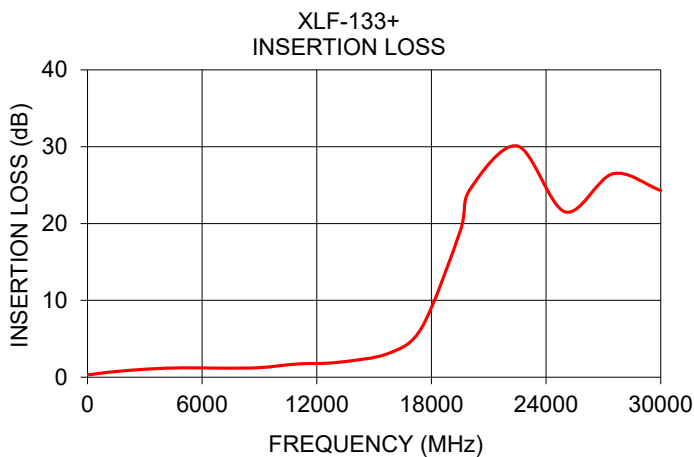



MMIC REFLECTIONLESS

Low Pass Filter

XLF-133+



50Ω DC to 13100 MHz

ADDITIONAL DETAILED TECHNICAL INFORMATION IS AVAILABLE ON OUR DASH BOARD. TO ACCESS [CLICK HERE](#)

Performance Data & Graphs	Data Graphs S-Parameter (S2P Files) Data Set (.zip file)
Case Style	DQ1225 Plastic package, exposed paddle lead finish: matte-tin
Tape & Reel Standard quantities available on reel	F66 7" reels with 20, 50, 100, 200, 500, 1000, 2000, 3000 devices
Suggested Layout for PCB Design	PL-451
Evaluation Board	TB-844-133+ (without connectors) TB-844-133C+ (with connectors) B20-118-F1+ connector sold separately
Environmental Ratings	ENV82

ESD RATING

Human body model (HBM): Class 1A (250 to <500V) in accordance with ANSI/ESD 5.1-2001

MSL RATING

Moisture Sensitivity: MSL1 in accordance with IPC/JEDEC J-STD-020D





REFLECTIONLESS FILTER APPLICATION NOTE

Application Circuit Example: Pairing mixers with reflectionless filters to improve system dynamic range

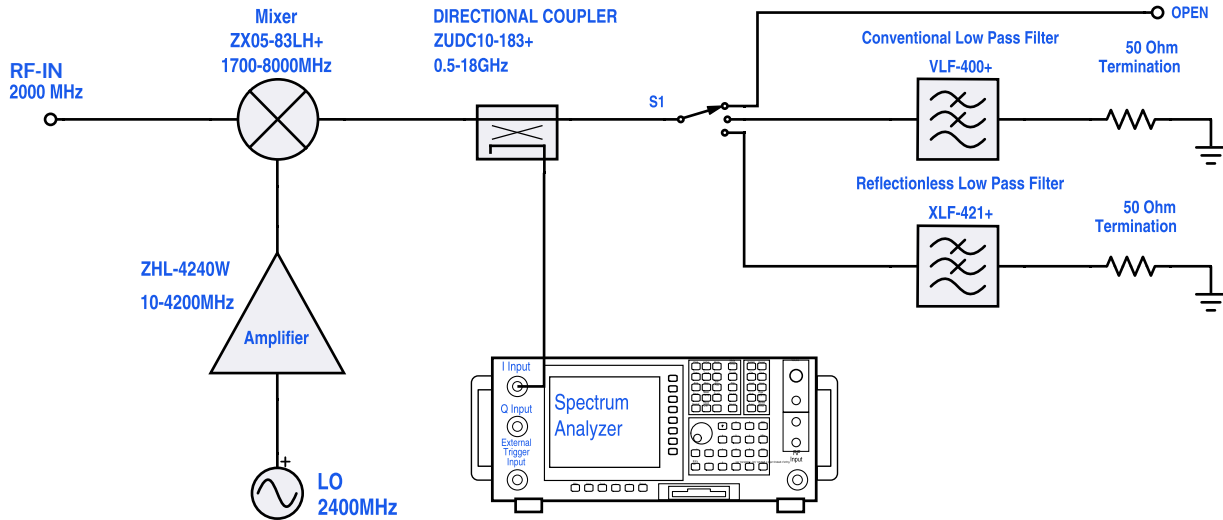

Test block diagram: IF output reflection spectrum with single input frequency

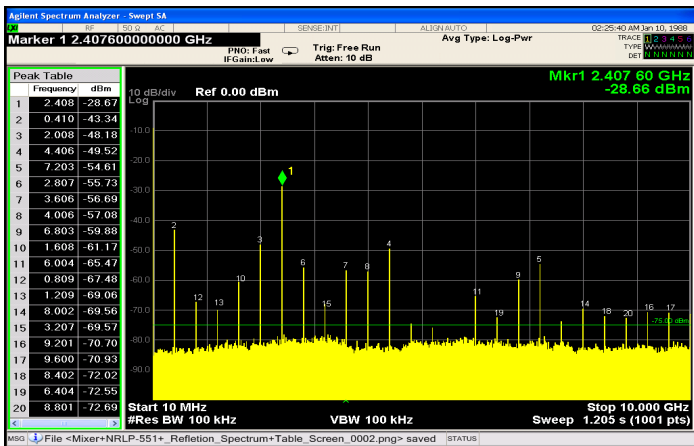

Figure 1. IF output reflection spectrum without filter

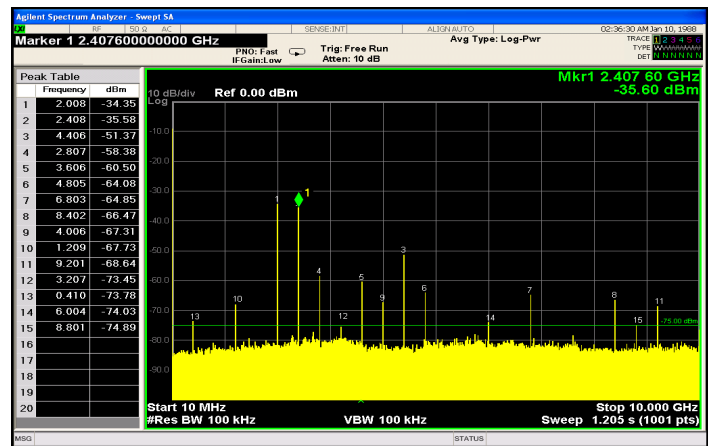
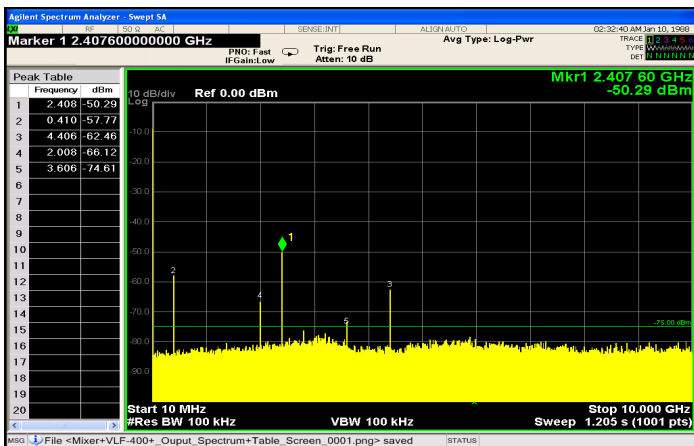

Figure 2. IF output reflection spectrum with conventional filter



NOTES

- A. Performance and quality attributes and conditions not expressly stated in this specification document are intended to be excluded and do not form a part of this specification document.
- B. Electrical specifications and performance data contained in this specification document are based on Mini-Circuit's applicable established test performance criteria and measurement instructions.
- C. The parts covered by this specification document are subject to Mini-Circuits standard limited warranty and terms and conditions (collectively, "Standard Terms"); Purchasers of this part are entitled to the rights and benefits contained therein. For a full statement of the standard terms and the exclusive rights and remedies thereunder, please visit Mini-Circuits' website at www.minicircuits.com/MCLStore/terms.jsp

Typical Performance Data

FREQ. (MHz)	INSERTION LOSS					GROUP DELAY				
	(dB)					(nsec)				
	@-55°C	@-40°C	@+25°C	@+85°C	@+105°C	@-55°C	@-40°C	@+25°C	@+85°C	@+105°C
10	0.38	0.38	0.42	0.45	0.44	0.05	0.05	0.06	0.02	0.03
50	0.34	0.34	0.38	0.40	0.41	0.05	0.05	0.05	0.04	0.05
100	0.33	0.34	0.38	0.41	0.42	0.05	0.05	0.04	0.04	0.04
200	0.32	0.33	0.38	0.41	0.42	0.05	0.05	0.04	0.04	0.04
300	0.33	0.33	0.40	0.42	0.43	0.04	0.04	0.04	0.04	0.04
400	0.33	0.33	0.40	0.44	0.44	0.04	0.04	0.04	0.04	0.04
500	0.32	0.34	0.40	0.44	0.45	0.04	0.04	0.04	0.04	0.04
600	0.32	0.34	0.41	0.45	0.47	0.04	0.04	0.04	0.04	0.04
700	0.33	0.34	0.42	0.46	0.47	0.04	0.04	0.04	0.04	0.04
800	0.32	0.34	0.43	0.47	0.49	0.04	0.04	0.04	0.04	0.04
900	0.33	0.35	0.44	0.48	0.50	0.04	0.04	0.04	0.04	0.04
1000	0.33	0.35	0.44	0.48	0.50	0.04	0.04	0.04	0.04	0.04
1500	0.35	0.38	0.49	0.54	0.55	0.04	0.04	0.04	0.04	0.03
2000	0.37	0.40	0.52	0.57	0.60	0.04	0.04	0.03	0.03	0.03
2500	0.39	0.42	0.55	0.60	0.62	0.04	0.04	0.03	0.03	0.03
3000	0.38	0.41	0.55	0.62	0.64	0.04	0.04	0.03	0.03	0.03
3500	0.38	0.41	0.57	0.64	0.66	0.04	0.04	0.03	0.04	0.04
4000	0.38	0.42	0.59	0.67	0.70	0.04	0.04	0.04	0.03	0.04
4500	0.38	0.42	0.61	0.70	0.74	0.04	0.04	0.04	0.04	0.03
5000	0.40	0.44	0.64	0.74	0.79	0.04	0.04	0.04	0.04	0.03
5500	0.40	0.45	0.66	0.78	0.82	0.04	0.04	0.04	0.04	0.03
6000	0.42	0.46	0.68	0.81	0.85	0.04	0.04	0.04	0.04	0.04
6500	0.42	0.47	0.70	0.83	0.88	0.04	0.04	0.04	0.04	0.04
7000	0.42	0.47	0.73	0.86	0.91	0.04	0.04	0.04	0.04	0.04
7500	0.42	0.47	0.75	0.90	0.96	0.05	0.04	0.04	0.04	0.04
8000	0.43	0.49	0.78	0.95	1.01	0.04	0.04	0.04	0.04	0.04
8500	0.44	0.51	0.82	0.99	1.07	0.05	0.05	0.04	0.04	0.04
9000	0.50	0.57	0.89	1.07	1.16	0.05	0.05	0.04	0.04	0.04
9500	0.56	0.63	0.97	1.17	1.24	0.05	0.05	0.04	0.04	0.04
10000	0.70	0.77	1.10	1.31	1.37	0.05	0.05	0.04	0.04	0.04
10500	0.87	0.94	1.27	1.46	1.53	0.05	0.05	0.04	0.04	0.04
11000	0.97	1.04	1.41	1.64	1.71	0.05	0.05	0.04	0.04	0.04
11500	1.00	1.09	1.53	1.79	1.88	0.05	0.05	0.04	0.04	0.04
12000	1.04	1.13	1.60	1.90	2.00	0.05	0.05	0.05	0.04	0.04
12500	1.11	1.19	1.65	1.95	2.06	0.06	0.06	0.05	0.05	0.05
13000	1.22	1.29	1.69	1.98	2.09	0.06	0.06	0.05	0.05	0.05
13100	1.25	1.32	1.71	1.99	2.10	0.06	0.06	0.05	0.05	0.05
13500	1.32	1.40	1.76	2.03	2.13	0.06	0.06	0.06	0.06	0.06
14000	1.38	1.47	1.87	2.15	2.25	0.06	0.06	0.06	0.06	0.06
14500	1.40	1.51	2.01	2.35	2.47	0.07	0.07	0.07	0.07	0.07
15000	1.47	1.60	2.25	2.66	2.81	0.08	0.08	0.07	0.07	0.07
15500	1.68	1.82	2.56	3.06	3.23	0.09	0.09	0.08	0.08	0.08
15800	1.91	2.07	2.83	3.37	3.57	0.09	0.09	0.08	0.08	0.08
16000	2.11	2.27	3.03	3.59	3.79	0.10	0.09	0.09	0.09	0.08
16500	2.81	2.97	3.69	4.27	4.48	0.10	0.10	0.09	0.10	0.10
17000	3.65	3.84	4.61	5.24	5.45	0.10	0.10	0.10	0.10	0.10
17500	4.66	4.89	5.88	6.63	6.89	0.12	0.12	0.11	0.11	0.11
18000	6.07	6.35	7.67	8.65	8.97	0.13	0.13	0.12	0.11	0.12
18500	8.15	8.47	10.04	11.21	11.63	0.13	0.14	0.12	0.12	0.12
19000	10.88	11.25	13.04	14.44	14.93	0.15	0.15	0.14	0.13	0.13
19500	14.45	14.85	16.87	18.65	19.28	0.16	0.16	0.15	0.15	0.14
20000	19.32	19.88	22.38	24.55	25.34	0.18	0.17	0.15	0.14	0.12
20500	26.44	27.11	30.01	32.38	33.21	0.17	0.17	0.10	0.04	0.05
21000	35.91	36.45	37.98	39.54	39.80	-0.02	-0.04	-0.02	-0.02	-0.02
21500	41.23	41.20	39.85	39.53	39.85	-0.06	-0.08	0.06	0.18	0.14
22000	38.23	37.61	36.50	35.63	35.47	0.01	0.04	0.07	0.11	0.11
22500	33.74	33.73	32.84	32.01	31.68	0.08	0.07	0.11	0.09	0.12
23000	29.86	29.82	29.53	29.02	28.82	0.11	0.08	0.08	0.09	0.09
24000	24.31	24.35	25.03	25.10	25.17	0.10	0.09	0.07	0.08	0.08
25000	21.99	22.01	22.12	22.64	22.98	0.11	0.10	0.09	0.09	0.10
26000	21.20	21.33	21.72	22.37	22.66	0.11	0.11	0.11	0.12	0.12
27000	22.37	22.57	23.64	24.53	25.04	0.14	0.15	0.15	0.12	0.16
28000	24.67	25.09	26.98	28.90	29.07	0.26	0.21	0.18	0.27	0.25
29000	25.44	25.69	26.90	28.18	28.72	0.23	0.24	0.22	0.18	0.16
30000	24.31	24.47	24.38	25.06	25.23	0.10	0.12	0.14	0.13	0.13
31000	22.73	22.93	23.63	23.59	23.43	0.06	0.07	0.04	0.09	0.08
32000	21.99	22.13	23.85	24.45	24.57	0.13	0.10	0.01	-0.01	0.03
33000	24.52	24.28	23.92	24.81	25.37	0.00	-0.04	0.05	-0.03	-0.03
33500	25.16	24.97	23.34	24.29	25.01	-0.07	-0.02	0.03	-0.01	-0.01
34000	25.01	24.75	23.04	23.40	24.02	-0.02	-0.02	0.02	-0.01	0.01
35000	22.99	22.84	21.71	21.29	21.31	-0.04	-0.03	0.03	0.02	0.00
36000	18.30	18.53	19.74	19.62	19.23	0.05	0.05	-0.01	0.04	0.02
37000	15.31	15.20	16.79	17.60	17.69	0.10	0.09	0.01	0.02	0.01
38000	14.29	14.21	13.75	14.48	15.01	0.03	0.02	0.05	0.04	0.04
39000	11.49	11.56	11.05	11.19	11.56	0.05	0.05	0.06	0.08	0.09
40000	7.91	8.20	9.85	10.40	10.48	0.10	0.12	0.00	0.03	0.07



Typical Performance Curves

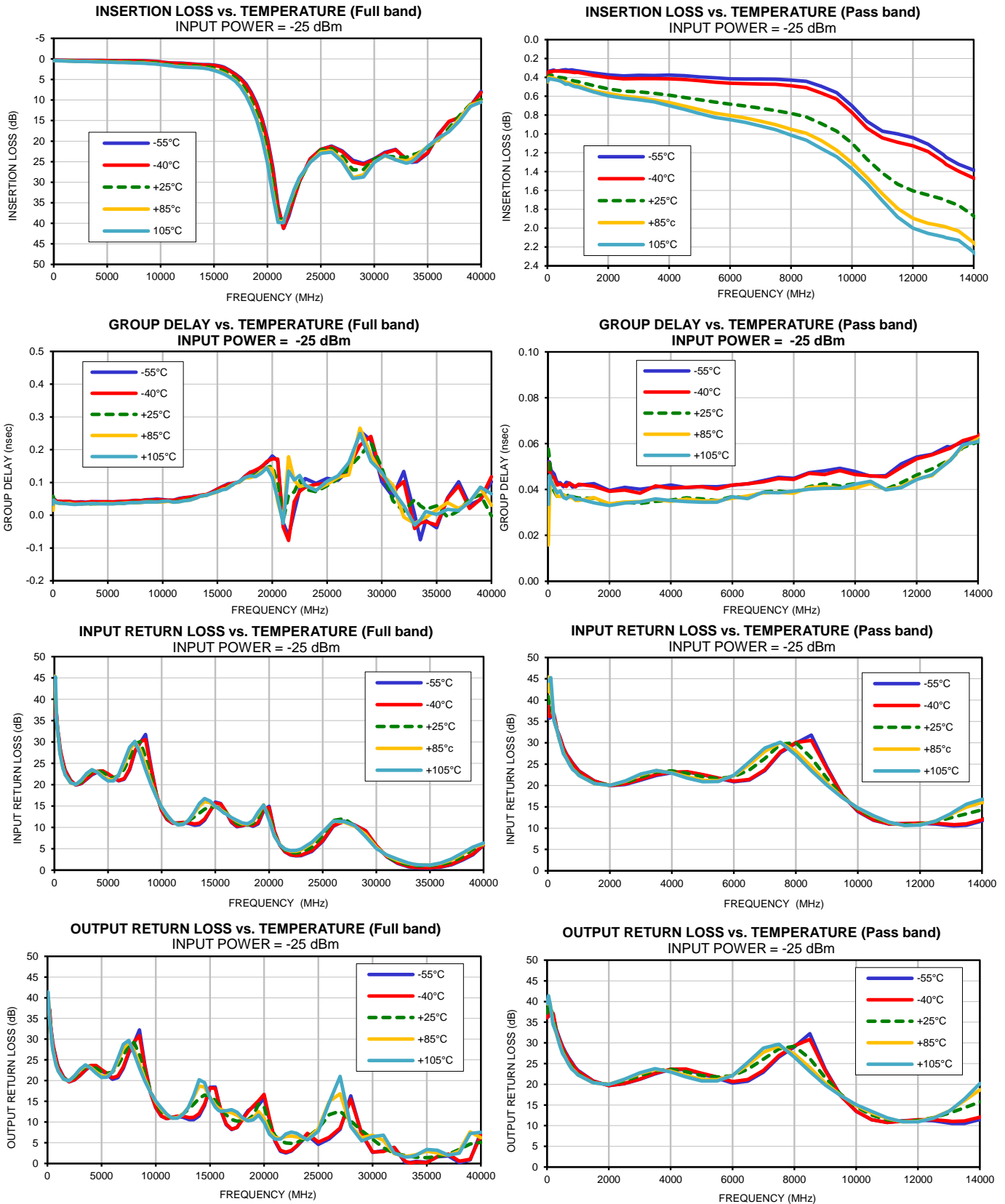

Outline Dimensions



PCB Land Pattern

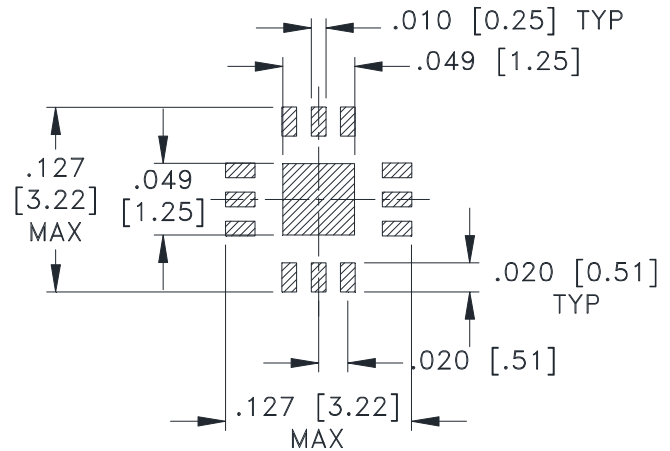

SUGGESTED LAYOUT,
TOLERANCE TO BE WITHIN $\pm .002$

Weight: .02 Grams

Dimensions are in inches (mm). Tolerances: 2Pl. $\pm .01$; 3 Pl. $\pm .004$

Notes:

1. Case material: Plastic.
2. Termination finish:
 - For RoHS Case Styles: Tin-Silver alloy plate over Nickel barrier or Matte-Tin. All models, (+) suffix. See Data sheet.
 - For RoHS-5 Case Styles: Tin-Lead plate. All models, no (+) suffix.

Tape & Reel Packaging TR-F66



Tape Width, mm	Device Cavity Pitch, mm	Reel Size, inches	Devices per Reel see note	
8	4	7	Small quantity standard	20
				50
				100
				200
				500
		7	Standard	1000, 2000, 3000

Note: Please consult individual model data sheet to determine device per reel availability.

Mini-Circuits carrier tape materials provide protection from ESD (Electro-Static Discharge) during handling and transportation. Tapes are static dissipative and comply with industry standards EIA-481/EIA-541.

Go to: www.minicircuits.com/pages/pdfs/tape.pdf

Mini-Circuits®

INTERNET <http://www.minicircuits.com>

P.O. Box 350166, Brooklyn, New York 11235-0003 (718) 934-4500 Fax (718) 332-4661

Distribution Centers NORTH AMERICA 800-654-7949 • 417-335-5935 • Fax 417-335-5945 • EUROPE 44-1252-832600 • Fax 44-1252-837010

Mini-Circuits ISO 9001 & ISO 14001 Certified

THIRD ANGLE PROJECTION



REVISIONS

REV	ECN No.	DESCRIPTION	DATE	DR	AUTH
OR	M152656	NEW RELEASE	09/11/15	ITG	MY

SUGGESTED MOUNTING CONFIGURATION
FOR DQ1225 CASE STYLE, "12FL02" PIN CODE

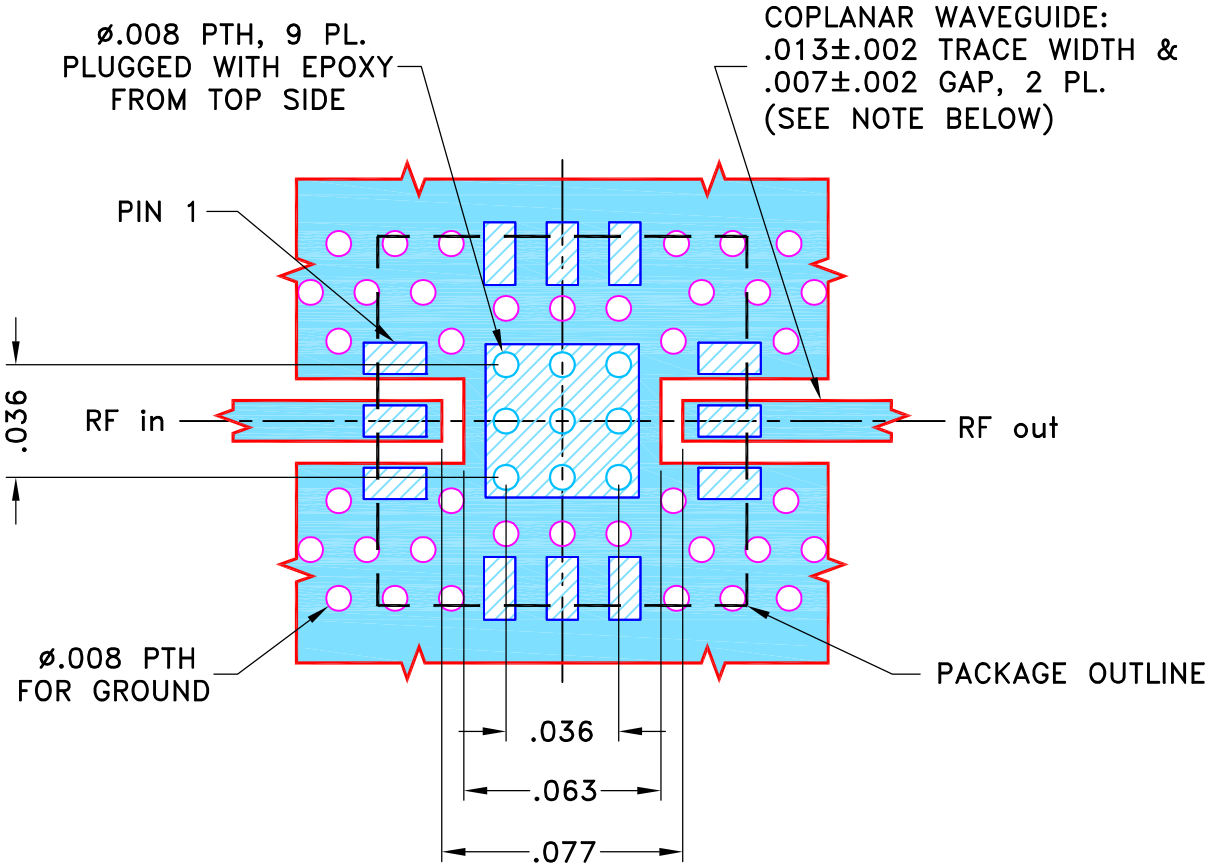

NOTES:

- TRACE WIDTH PARAMETERS ARE SHOWN FOR ROGERS R04350B WITH DIELECTRIC THICKNESS $.0066 \pm .0007$ ". COPPER: 1/2 OZ. EACH SIDE. FOR OTHER MATERIALS TRACE WIDTH AND GAP MAY NEED TO BE MODIFIED.
- BOTTOM SIDE OF THE PCB IS CONTINUOUS GROUND PLANE.

- DENOTES PCB COPPER LAYOUT WITH SMOBC (SOLDER MASK OVER BARE COPPER).
- DENOTES COPPER LAND PATTERN FREE OF SOLDER MASK.

UNLESS OTHERWISE SPECIFIED	INITIALS		DATE
DIMENSIONS ARE IN INCHES TOLERANCES ON: 2 PL DECIMALS ± 3 PL DECIMALS ± .005 ANGLES ± FRACTIONS ±	DRAWN	ITG	09/10/15
	CHECKED	GF	09/11/15
	APPROVED	MY	09/11/15

Mini-Circuits[®] 13 Neptune Avenue
Brooklyn NY 11235

PL, 12FL02, DQ1225, TB-844+

Mini-Circuits[®]
THIS DOCUMENT AND ITS CONTENTS ARE THE PROPERTY OF MINI-CIRCUITS. EXCEPT FOR USE EXPRESSLY GRANTED, IN WRITING, TO ITS VENDORS, VENDEE AND THE UNITED STATES GOVERNMENT, MINI-CIRCUITS RESERVES ALL PROPRIETARY DESIGN, USE, MANUFACTURING AND REPRODUCTION RIGHTS THERETO. THESE CONTENTS SHALL NOT BE USED, DUPLICATED OR DISCLOSED TO ANY OUTSIDE PARTY, IN WHOLE OR IN PART, WITHOUT WRITTEN PERMISSION OF MINI-CIRCUITS.

SIZE A	CODE IDENT 15542	DRAWING NO: 98-PL-451	REV: OR
FILE: 98PL451	SCALE: 16:1	SHEET: 1 OF 1	

Evaluation Board and Circuit

To be used with Mini-Circuits 50 Ohm 2.92 connectors B20-118-F1+.
Connectors are sold separately.

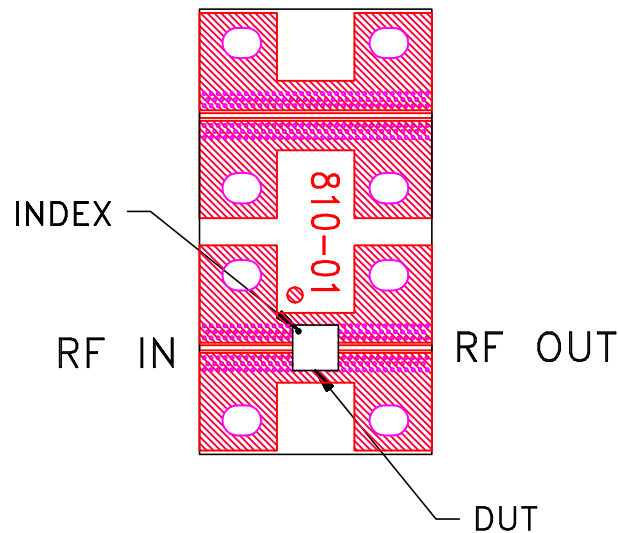

TB-844-133+

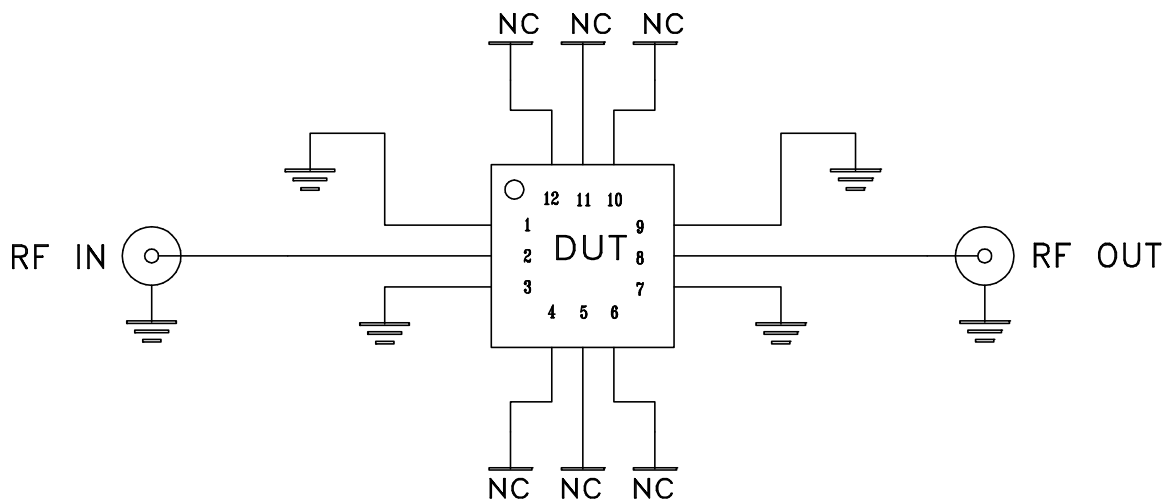

Schematic Diagram

Note:

PCB Material: R04350 or equivalent,
Dielectric Constant=3.5, Thickness=.0066 inch.

 **Mini-Circuits®**

Evaluation Board and Circuit

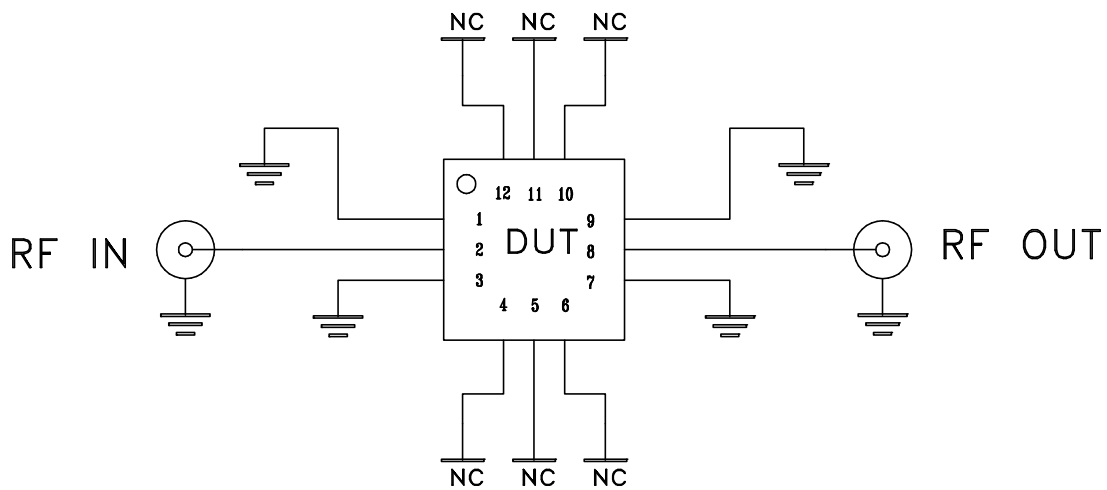
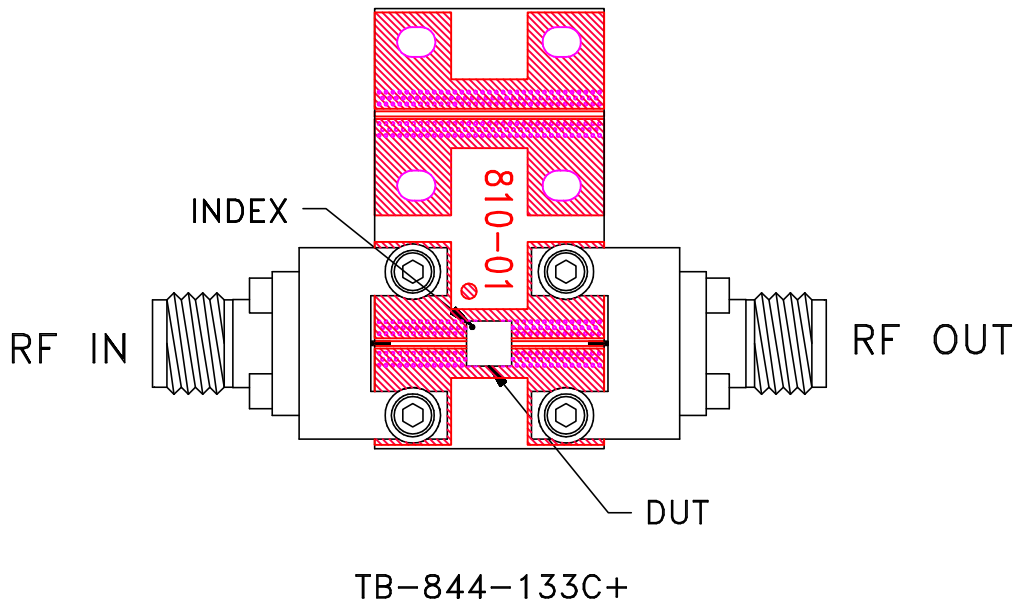

Schematic Diagram

Notes:

1. 50 Ohm 2.92 mm Female connectors.
2. PCB Material: R04350 or equivalent,
Dielectric Constant=3.5, Thickness=.0066 inch.

 **Mini-Circuits®**



All Mini-Circuits products are manufactured under exacting quality assurance and control standards, and are capable of meeting published specifications after being subjected to any or all of the following physical and environmental test.

Specification	Test/Inspection Condition	Reference/Spec
Operating Temperature	-55° to 105°C Ambient Environment	Individual Model Data Sheet
Storage Temperature	-65° to 150° C Ambient Environment	Individual Model Data Sheet
Autoclave	15 psig, 100% RH, 121°C, 96 hours	JESD22-A102-C, Condition C
Temperature Cycling	-65° to 150°C, 100 cycles	JESD22-A104
Temperature Humidity	85°C/ 85% RH, 168 hours	JESD22-113
Solder Reflow Heat	Sn-Pb Eutetic Process: 240°C peak Pb-Free Process: 260°C peak	J-STD-020, Table 4-1, 4-2 and 5-2; Figure 5-1
Moisture Sensitivity: Level 1	Bake at 125°C for 24 hours Soak at 85°C/85% RH for 168 hours, Reflow 3 cycles at 240°C peak (Non-RoHS) or 260°C (RoHS)	J-STD-020C
Solderability	10X magnification, 95% coverage	JESD22-B102, Method 1: Dip and Look Test
Marking Resistance to Solvents	Isopropyl alcohol + mineral spirits at 25°C; terpene defluxer at 25°C; distilled water + proylene glycol monomethyl ether + monoethanolamine at 63°C to 70°C	MIL-STD-202, Method 215