

Bandpass Filters

WVBP Series

50Ω Frequency Bands from: 27 to 86 GHz

The Big Deal

- Precision Machining and Plating
- Outstanding Return Loss
- Super-High Rejection & Fast Roll-Off



Product Overview

Mini-Circuits and Virginia Diodes have teamed together to offer a new series of high-performance, high-fidelity waveguide bandpass filters for millimeter wave applications. WVBP-series filters are available in various bands spanning 27 to 86 GHz and are offered with standard WR waveguide interfaces. Built with precise machine tolerances and outstanding quality plating, WVBP-series filters provide low insertion loss in the passband, outstanding return loss, and high stopband rejection with fast roll-off.

WVBP-series waveguide bandpass filters are built upon Virginia Diodes' distinguished experience developing metrology-grade equipment for millimeter-wave and THz bands, bringing leading-edge capabilities to Mini-Circuits customers working in high-frequency applications.

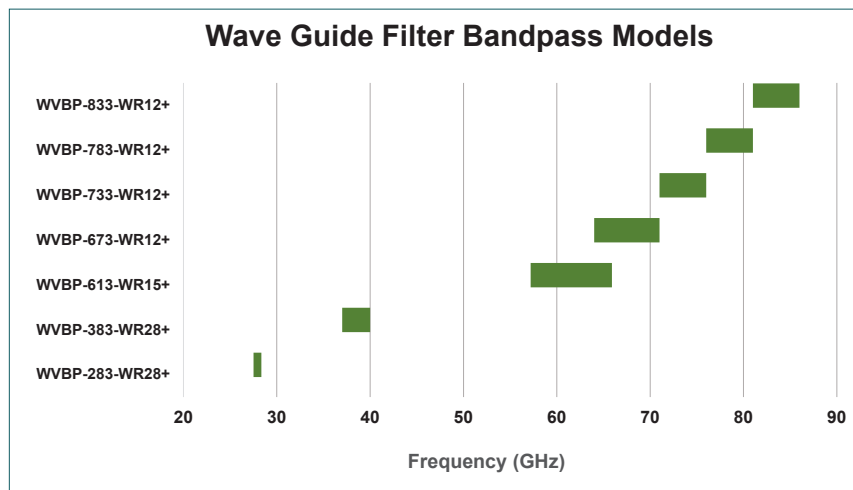

About Virginia Diodes, Inc.

Virginia Diodes, Inc. develops and manufactures devices, components and systems for the millimeter-wave and terahertz frequency bands. This includes direct detectors, frequency mixers and multipliers, receiver systems, and sources operating to frequencies as high as five terahertz. Test and Measurement products include frequency extenders for the range from 26 GHz to 1.5 THz for Vector Network Analyzers, Spectrum Analyzers and Signal Generators. VDI also offers select passive components, including high frequency waveguide filters, which have been developed to enable high-quality measurement systems throughout this emerging frequency band.

Notes

- Performance and quality attributes and conditions not expressly stated in this specification document are intended to be excluded and do not form a part of this specification document.
- Electrical specifications and performance data contained in this specification document are based on Mini-Circuit's applicable established test performance criteria and measurement instructions.
- The parts covered by this specification document are subject to Mini-Circuits standard limited warranty and terms and conditions (collectively, "Standard Terms"); Purchasers of this part are entitled to the rights and benefits contained therein. For a full statement of the Standard Terms and the exclusive rights and remedies thereunder, please visit Mini-Circuits' website at www.minicircuits.com/MCLStore/terms.jsp



Bandpass Filter

WVBP-833-WR12+

81 to 86 GHz

Features

- Low insertion loss, 0.5 dB typ.
- Excellent return loss, 26 dB typ.
- High rejection
- Fast roll-off

Applications

- WiGig
- Test lab
- Multimeter wave equipment
- Satellite



CASE STYLE: TH2793



Electrical Specifications at 25°C

Parameter		F#	Frequency (GHz)	Min.	Typ.	Max.	Unit
Pass Band	Center Frequency	—	—	—	83.5	—	GHz
	Insertion Loss	F1 - F2	81 - 86	—	0.5	1.0	dB
	Return Loss	F1 - F2	81 - 86	—	26	—	dB
Stop Band, Lower	Insertion Loss	F5	60	—	90	—	dB
		F3	79	20	38	—	
Stop Band, Upper	Insertion Loss	F4	88	20	26	—	dB
		F6	90	—	49	—	
Waveguide Interface Flange		—	—	WR12			—
		—	—	UG-387/U-M			—

Maximum Ratings

Operating Temperature -40°C to +85°C

Permanent damage may occur if any of these limits are exceeded.

+RoHS Compliant

The +Suffix identifies RoHS Compliance. See our web site for RoHS Compliance methodologies and qualifications

Outline Drawing

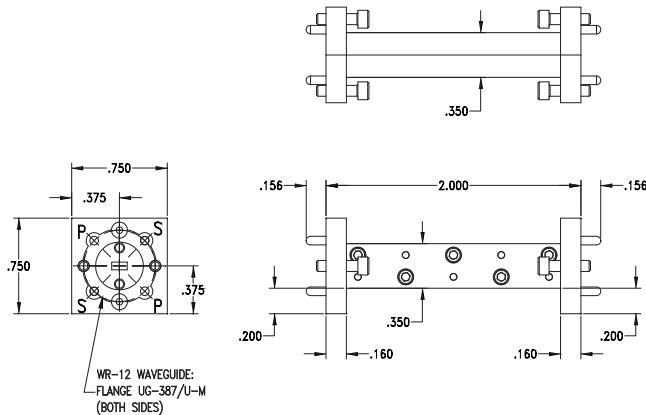

Typical Frequency Response

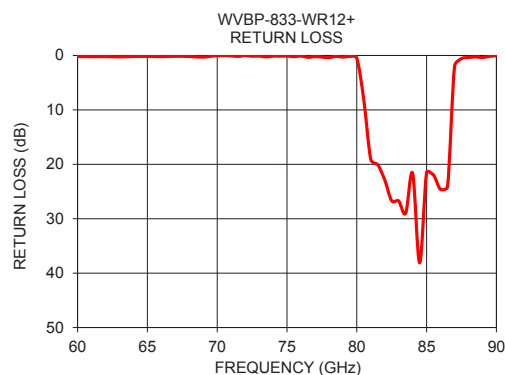
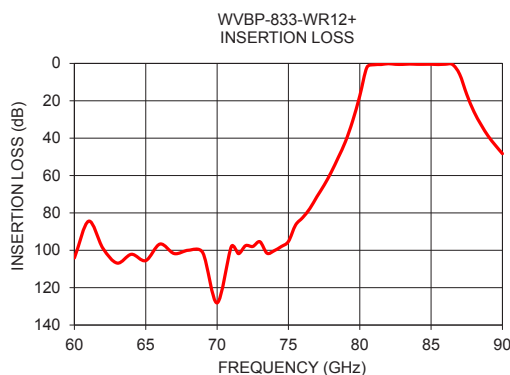
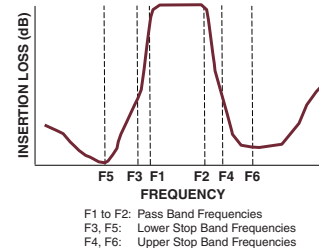

Notes

- A. Performance and quality attributes and conditions not expressly stated in this specification document are intended to be excluded and do not form a part of this specification document.
 B. Electrical specifications and performance data contained in this specification document are based on Mini-Circuit's applicable established test performance criteria and measurement instructions.
 C. The parts covered by this specification document are subject to Mini-Circuits standard limited warranty and terms and conditions (collectively, "Standard Terms"); Purchasers of this part are entitled to the rights and benefits contained therein. For a full statement of the Standard Terms and the exclusive rights and remedies thereunder, please visit Mini-Circuits' website at www.minicircuits.com/MCLStore/terms.jsp



www.minicircuits.com P.O. Box 350166, Brooklyn, NY 11235-0003 (718) 934-4500 sales@minicircuits.com

REV. OR
M171564
WVBP-833-WR12+
RS/CP/AM
181220
Page 2 of 2

Typical Performance Data

FREQUENCY (GHz)	INSERTION LOSS (dB)	RETURN LOSS (dB)
60.0	104.13	0.18
61.0	84.41	0.23
62.0	98.95	0.20
63.0	106.85	0.25
64.0	102.13	0.19
65.0	105.51	0.17
66.0	96.65	0.21
67.0	101.77	0.14
68.0	99.97	0.19
69.0	101.33	0.30
70.0	128.15	0.03
71.0	97.99	0.07
71.5	101.81	0.17
72.0	97.51	0.01
72.5	97.95	0.14
73.0	95.41	0.10
73.5	101.57	0.26
74.0	100.23	0.12
74.5	98.00	0.13
75.0	95.28	0.10
75.5	86.50	0.22
76.0	82.50	0.10
76.5	77.68	0.34
77.0	71.28	0.21
77.5	65.17	0.29
78.0	58.19	0.41
78.5	50.22	0.16
79.0	41.78	0.29
79.5	30.82	0.18
80.0	17.39	0.49
80.5	2.12	8.14
81.0	0.72	19.07
81.5	0.58	20.07
82.0	0.15	22.87
82.5	0.48	26.72
83.0	0.52	26.74
83.5	0.35	29.00
84.0	0.47	21.66
84.5	0.47	38.12
85.0	0.44	21.52
85.5	0.59	22.00
86.0	0.44	24.64
86.5	0.59	24.09
87.0	5.80	2.01
87.5	16.62	0.59
88.0	25.78	0.38
88.5	32.78	0.27
89.0	38.89	0.38
89.5	43.77	0.16
90.0	48.31	0.04

Waveguide Bandpass Filter

WVBP-833-WR12+

Typical Performance Curves

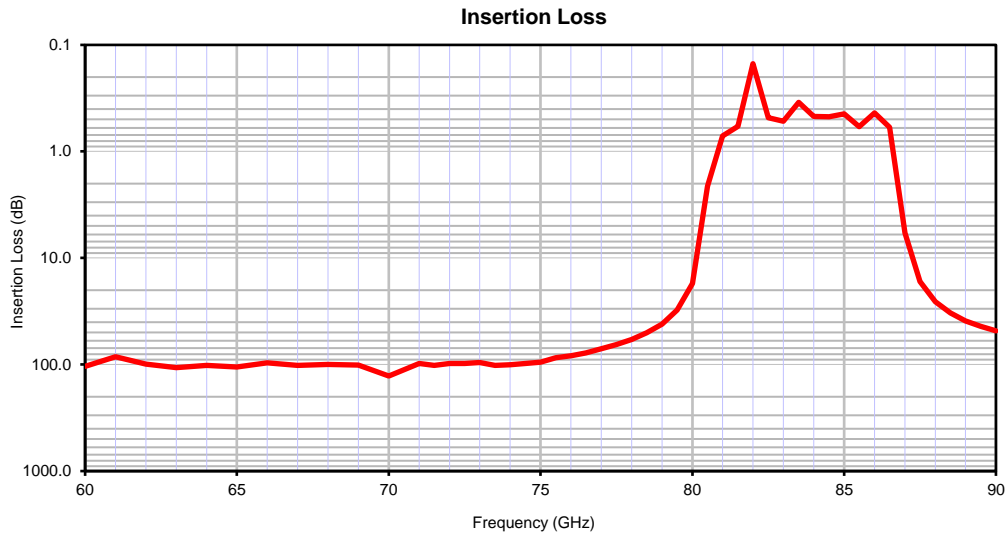

Case Style

TH

Outline Dimensions

TH2793

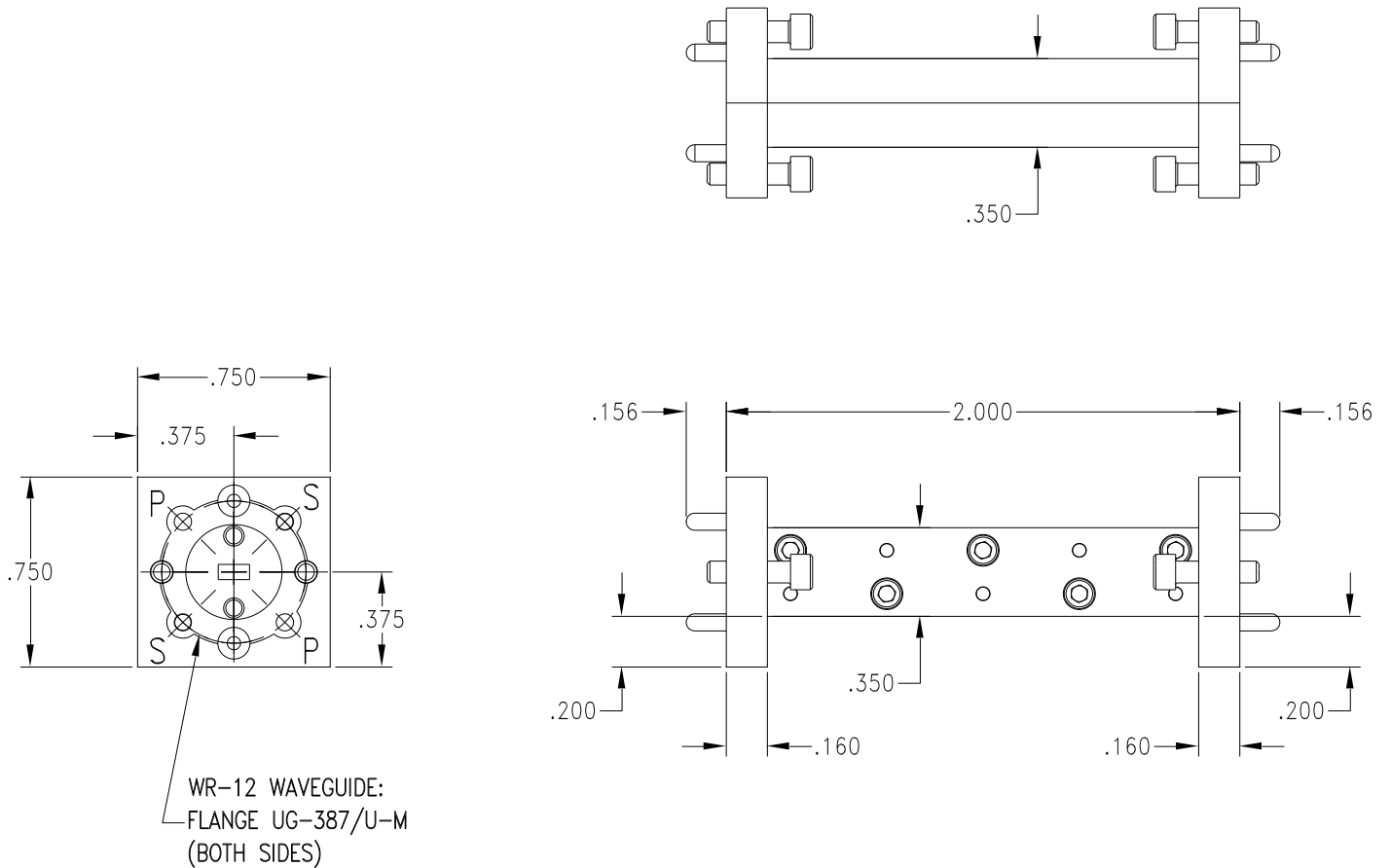

Tolerance: ± 0.002

Notes:

1. Case Material: Aluminum alloy.
2. Case Finish: Gold plating.
3. Weight: 200 grams
4. Item may be supplied with Dust Caps

Mini-Circuits®
ISO 9001 ISO 14001 CERTIFIED

ALL NEW
minicircuits.com

P.O. Box 350166, Brooklyn, New York 11235-0003 (718) 934-4500 Fax (718) 332-4661 For detailed performance specs & shopping online see Mini-Circuits web site



The Design Engineers Search Engine Provides ACTUAL Data Instantly From MINI-CIRCUITS At: www.minicircuits.com

RF/IF MICROWAVE COMPONENTS

All Mini-Circuits products are manufactured under exacting quality assurance and control standards, and are capable of meeting published specifications after being subjected to any or all of the following physical and environmental test.

Specification	Test/Inspection Condition	Reference/Spec
Operating Temperature	-40° to 85° C or -40° to 105° C or -55° to 105° C or -45° to 105° C Ambient Environment	Refer to Individual Model Data Sheet
Storage Environment (Die)	-65° to 150°C	Individual Model Data Sheet
Storage Environment(Packaging)	-40° to 70°C and 40 to 60% humidity (In Factory Shipped Package)	