

ADAPTER

Waveguide to Coax

WR19-EFR+

50Ω 40 to 60 GHz Right-Angle 1.85mm-F to WR19 UG383/U Flange

THE BIG DEAL

- Full U-band Frequency Range, 40 to 60 GHz
- Low Insertion Loss, 0.8 dB typ.
- Excellent Return Loss, 20 dB typ.
- Compact Right-Angle Design
- Precision UG383/U Waveguide Flange
- 1.85mm-Female Connector

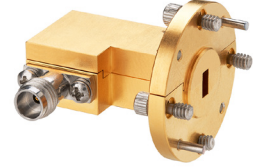

Generic photo used for illustration purposes only

Model No.	WR19-EFR+
Case Style	UW3147
Connector 1	1.85mm-Female
Connector 2	WR19 UG383/U Flange

+RoHS Compliant

The +Suffix identifies RoHS Compliance. See our website for methodologies and qualifications

APPLICATIONS

- Waveguide Sub-system Rapid Prototyping
- R&D, Production, and OTA Test Systems
- 5G MIMO and Back Haul Radio Systems
- Test & Measurement Equipment
- SATCOM Systems

PRODUCT OVERVIEW

Mini-Circuits' WR19-EFR+ is a waveguide to coax adapter operating from 40 to 60 GHz. This product features a WR19 waveguide interface with a precision standard UG383/U flange to 1.85mm-Female coaxial connector. The WR19-EFR+ is machined from aluminum alloy 6061-T6 and gold-plated to ensure repeatable RF performance. This right-angle adapter has applications in R&D, production, over-the-air (OTA) mmWave test laboratories as well as in U-Band communication and SATCOM systems.

KEY FEATURES

Feature	Advantages
Wideband, 40 to 60 GHz	Full operating frequency range of WR19 waveguide
Low insertion loss, 0.8 dB typ. Excellent return loss, 20 dB typ.	Provides a near transparent transition for critical coax to waveguide transition requirements
Precision machined with outstanding surface finish	Mini-Circuits mmWave waveguide to coaxial adapters utilize high precision machining for repeatable performance over full waveguide bands. The highly polished, match-machined surfaces are gold plated to 20 μinches minimum over 100 μinches minimum of nickel.

REV. OR
ECO-015832
WR19-EFR+
MCL NY
221219



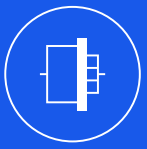

ADAPTER

Waveguide to Coax

WR19-EFR+

50Ω 40 to 60 GHz Right-Angle 1.85mm-F to WR19 UG383/U Flange

ELECTRICAL SPECIFICATIONS AT 25°C

Parameter	Condition (GHz)	Min.	Typ.	Max.	Units
Frequency Range		40		60	GHz
Insertion Loss ¹	40 - 60	—	0.8	—	dB
Return Loss ²	40 - 60	—	20.0	15.0	dB

1. Insertion loss is measured as return loss on coax port, with a short on waveguide port. Results are divided by 2.

2. Tested on coax port, with termination on waveguide port.

ABSOLUTE MAXIMUM RATINGS³

Parameter	Ratings
Operating Case Temperature	-40 °C to +85 °C
Storage Temperature	-55 °C to +100 °C

3. Permanent damage may occur if any of these limits are exceeded.

OUTLINE DRAWING

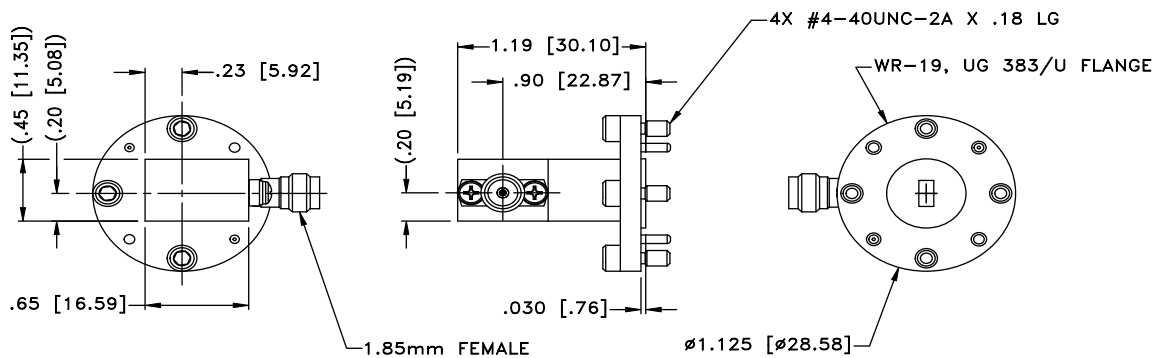

Dimensions are in inches [mm]. Tolerances 2Pl±.02; 3 Pl ±.010

Weight: 25 grams

Notes

1. Case material: Aluminum Alloy.
2. Case finish: Gold plating



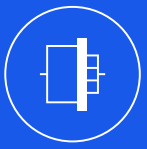

ADAPTER

Waveguide to Coax

WR19-EFR+

50Ω 40 to 60 GHz Right-Angle 1.85mm-F to WR19 UG383/U Flange

TYPICAL PERFORMANCE DATA / CHARTS

Frequency (GHz)	Insertion Loss (dB)	Return Loss (dB)
40	0.73	19.27
41	0.65	20.18
42	0.69	19.41
43	0.72	17.47
44	0.67	17.78
45	0.72	21.48
46	0.71	22.96
47	0.69	31.81
48	0.69	26.33
49	0.71	21.04
50	0.75	19.81
51	0.72	19.81
52	0.76	19.18
53	0.75	23.10
54	0.75	27.27
55	0.77	22.94
56	0.78	20.92
57	0.82	18.54
58	0.82	21.84
59	0.84	35.90
60	0.88	31.93

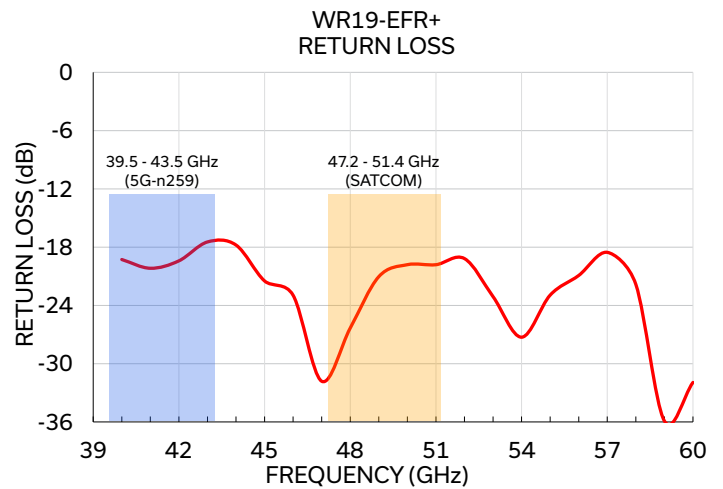
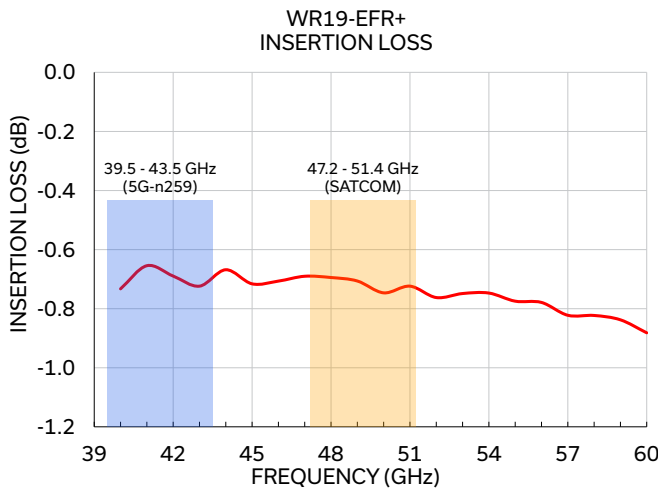

NOTES

- A. Performance and quality attributes and conditions not expressly stated in this specification document are intended to be excluded and do not form a part of this specification document.
- B. Electrical specifications and performance data contained in this specification document are based on Mini-Circuit's applicable established test performance criteria and measurement instructions.
- C. The parts covered by this specification document are subject to Mini-Circuits standard limited warranty and terms and conditions (collectively, "Standard Terms"); Purchasers of this part are entitled to the rights and benefits contained therein. For a full statement of the standard. Terms and the exclusive rights and remedies thereunder, please visit Mini-Circuits' website at www.minicircuits.com/MCLStore/terms.jsp



Adapter, Coaxial to Waveguide WR19-EFR+

Typical Performance Data

FREQUENCY (GHz)	INSERTION LOSS (dB)	RETURN LOSS (dB)
40.0	-0.73	-19.27
40.5	-0.67	-19.49
41.0	-0.65	-20.18
41.5	-0.70	-20.36
42.0	-0.69	-19.41
42.5	-0.66	-18.14
43.0	-0.72	-17.47
43.5	-0.73	-17.31
44.0	-0.67	-17.78
44.5	-0.71	-19.39
45.0	-0.72	-21.48
45.5	-0.68	-22.42
46.0	-0.71	-22.96
46.5	-0.71	-25.19
47.0	-0.69	-31.81
47.5	-0.70	-38.96
48.0	-0.69	-26.33
48.5	-0.70	-22.46
49.0	-0.71	-21.04
49.5	-0.71	-20.36
50.0	-0.75	-19.81
50.5	-0.74	-19.72
51.0	-0.72	-19.81
51.5	-0.76	-19.14
52.0	-0.76	-19.18
52.5	-0.74	-20.41
53.0	-0.75	-23.10
53.5	-0.75	-26.50
54.0	-0.75	-27.27
54.5	-0.76	-24.81
55.0	-0.77	-22.94
55.5	-0.79	-21.03
56.0	-0.78	-20.92
56.5	-0.79	-19.73
57.0	-0.82	-18.54
57.5	-0.82	-19.20
58.0	-0.82	-21.84
58.5	-0.84	-28.42
59.0	-0.84	-35.90
59.5	-0.84	-33.23
60.0	-0.88	-31.93

Typical Performance Curves

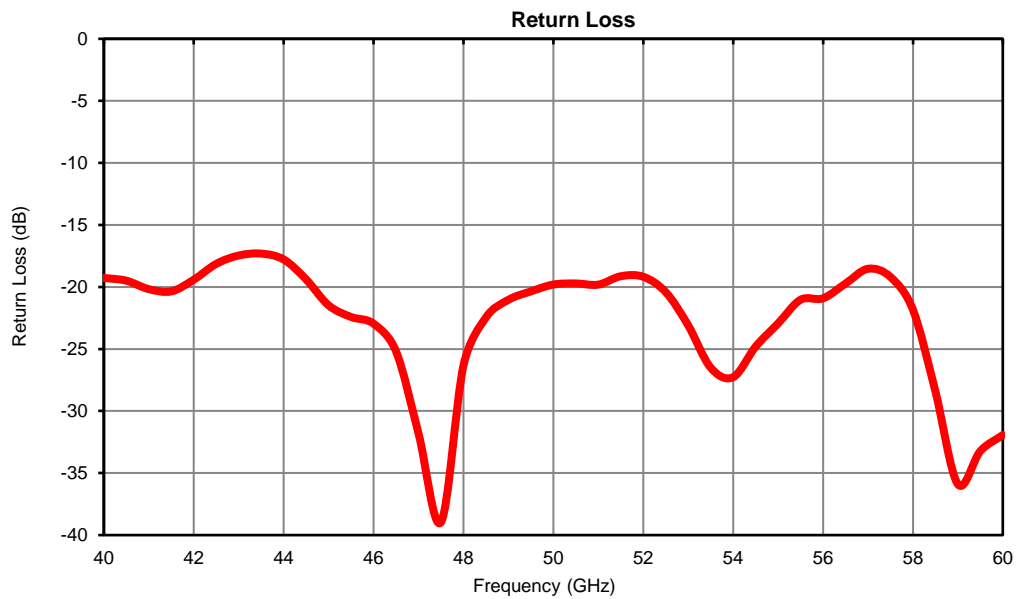
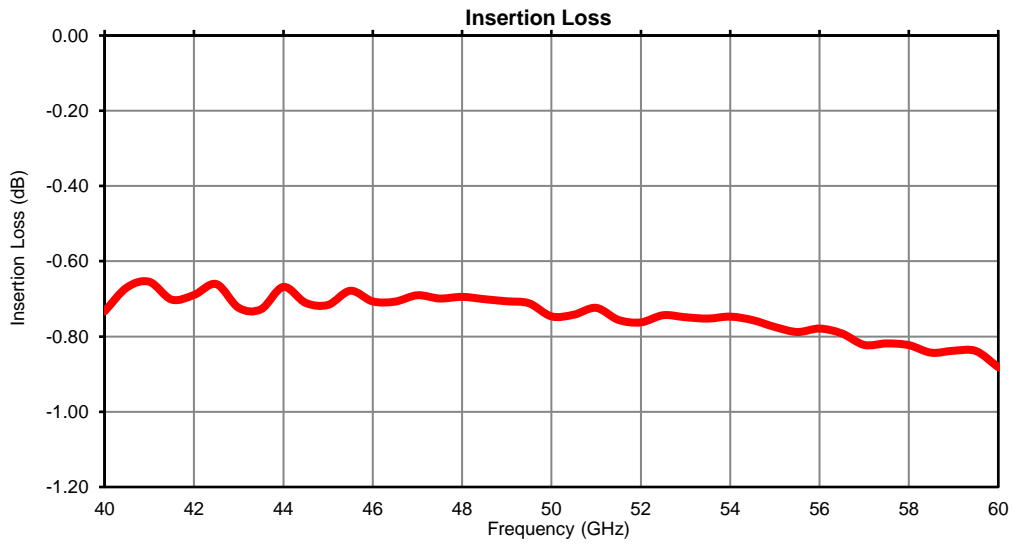

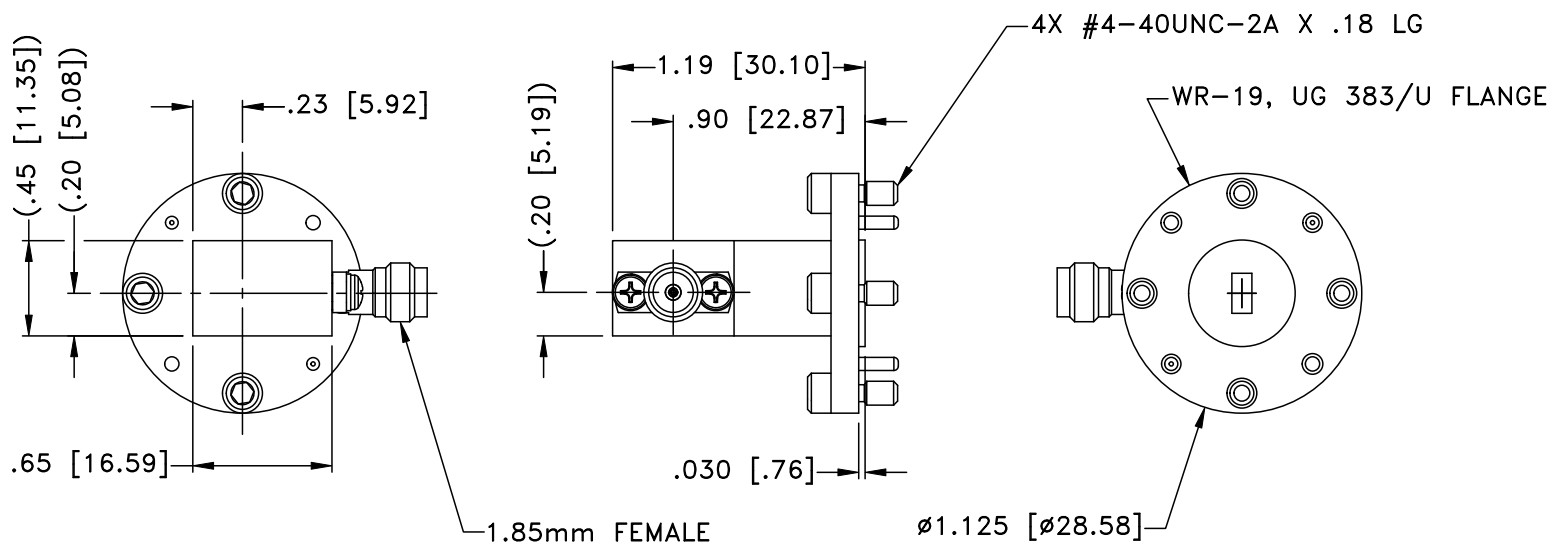

Dimensions are in inches (mm). Tolerances: 2 Pl $\pm .02$; 3 Pl $\pm .010$

Weight: 25 grams

Notes:

1. Case material: Aluminum Alloy.
2. Case finish: Gold plating;

Mini-Circuits®
ISO 9001 ISO 14001 CERTIFIED

ALL NEW
minicircuits.com

P.O. Box 350166, Brooklyn, New York 11235-0003 (718) 934-4500 Fax (718) 332-4661 For detailed performance specs & shopping online see Mini-Circuits web site



The Design Engineers Search Engine Provides ACTUAL Data Instantly From MINI-CIRCUITS At: www.minicircuits.com

RF/IF MICROWAVE COMPONENTS

All Mini-Circuits products are manufactured under exacting quality assurance and control standards, and are capable of meeting published specifications after being subjected to any or all of the following physical and environmental test.

Specification	Test/Inspection Condition	Reference/Spec
Operating Temperature	-40° to 85° C Ambient Environment	Individual Model Data Sheet
Storage Temperature	-55° to 100° C Ambient Environment	Individual Model Data Sheet
Thermal Shock	-55° to 100°C, 5 cycles	MIL-STD-202, Method 107, Condition B except over -55° to 100°C