



(LTCC) COAXIAL

High Pass Filter

VHFG-1630+

50Ω 1850 to 11000 MHz SMA Male/Female

KEY FEATURES

- Low Insertion Loss, 0.9 dB Typ.
- Return Loss, 13 dB Typ.
- Stop Band Rejection, 48 dB Typ.
- Rugged unibody construction
- Power Handling: 4 Watts

APPLICATIONS

- Test and Measurement Equipment
- Communications, Radar, EW, and ECM Defense Systems
- 5G MIMO and Back Haul Radio Systems
- 5G Sub 6 GHz
- WiFi 6E



Generic photo used for illustration purposes only

PRODUCT OVERVIEW

VHFG-1630+ is a 50ohm high pass filter built in rugged unibody construction. Covering 1850-11000 MHz bandwidth, these units offer good matching within the passband and good rejection in stopband. VHFG-1630+ offer low insertion loss, and excellent power handling capability. It handles up to 4 W RF input power and provides a wide operating temperature range from -55°C to 125°C.

FUNCTIONAL DIAGRAM

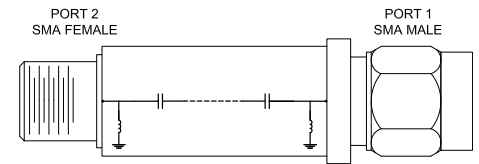

ELECTRICAL SPECIFICATIONS^{1,2} AT +25°C

Parameter		F#	Frequency (MHz)	Min.	Typ.	Max.	Units
Pass Band	Insertion Loss	F3-F4	1850 - 2800	—	2.0	—	dB
		F4-F5	2800 - 10000	—	0.9	1.6	
		F5-F6	10000 - 11000	—	2.0	—	
Pass Band	Return Loss	F3-F4	1850 - 2800	—	12	—	dB
		F4-F5	2800 - 10000	—	13	—	
		F5-F6	10000 - 11000	—	13	—	
Stop Band	Rejection	DC-F1	DC - 1000	42	48	—	dB
		F1-F2	1000 - 1300	20	31	—	
	Freq. Cut-Off ³	F _c ³	1630	—	3.0	—	dB

1. This filter is bi-directional, RF1 and RF2 ports may be interchanged, see S-Parameters for actual performance.

2. This component should not be used as a DC-block. In applications where DC voltage and/or current is present at either the input or output ports, external DC blocking capacitors are required.

3. Typical variation ± 5%

ABSOLUTE MAXIMUM RATINGS⁴

Parameter	Ratings
Operating Temperature	-55 °C to +125 °C
Storage Temperature	-55 °C to +125 °C
Input Power ⁵	4W @25°C

4. Permanent damage may occur if any of these limits are exceeded.

5. Power rating applies only to signals within the passband. Power rating above +25°C operating temperature decreases linearly to 0.9W at +125°C.

TYPICAL FREQUENCY RESPONSE

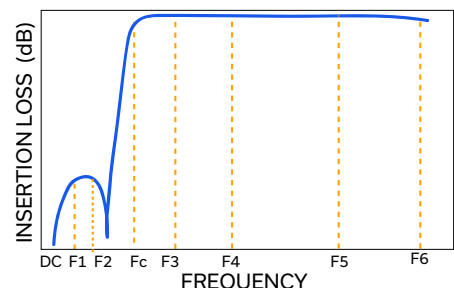



(LTCC) COAXIAL

High Pass Filter

VHFG-1630+

Mini-Circuits

50Ω 1850 to 11000 MHz SMA Male/Female

TYPICAL PERFORMANCE GRAPHS

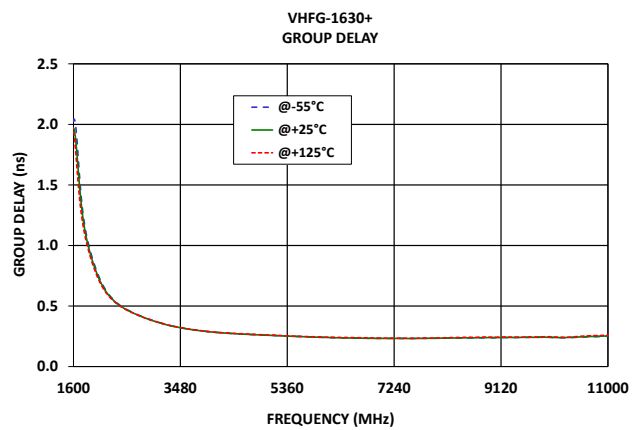
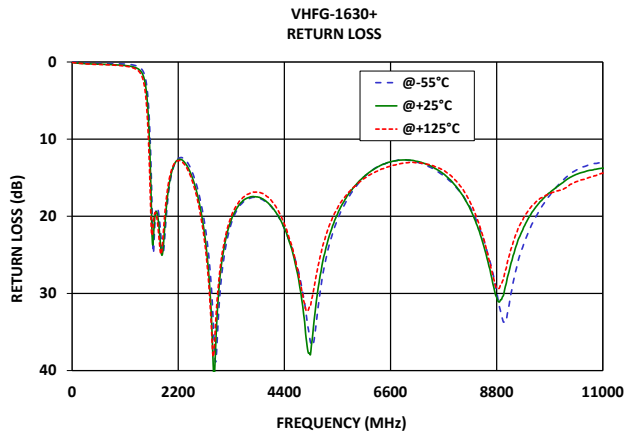
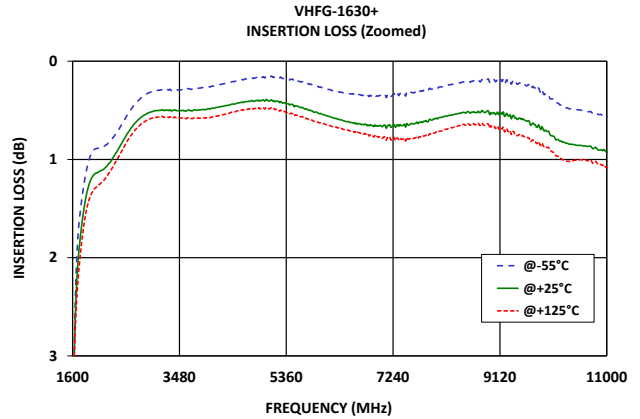
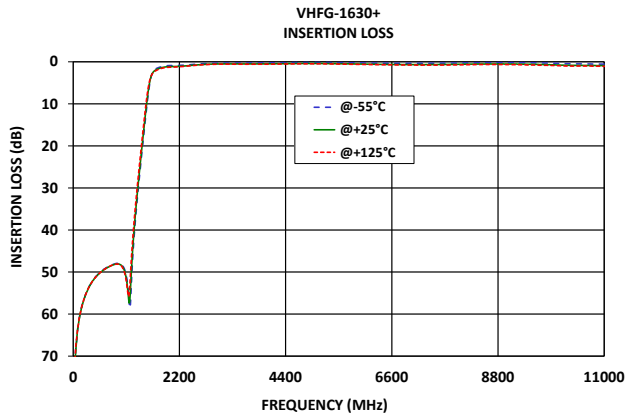



(LTCC) COAXIAL

High Pass Filter

VHFG-1630+

50Ω 1850 to 11000 MHz SMA Male/Female

CONNECTOR DESCRIPTION

Function	Functionality	Connector
RF1 ¹	Port-1	SMA MALE
RF2 ¹	Port-2	SMA FEMALE

CASE STYLE DRAWING

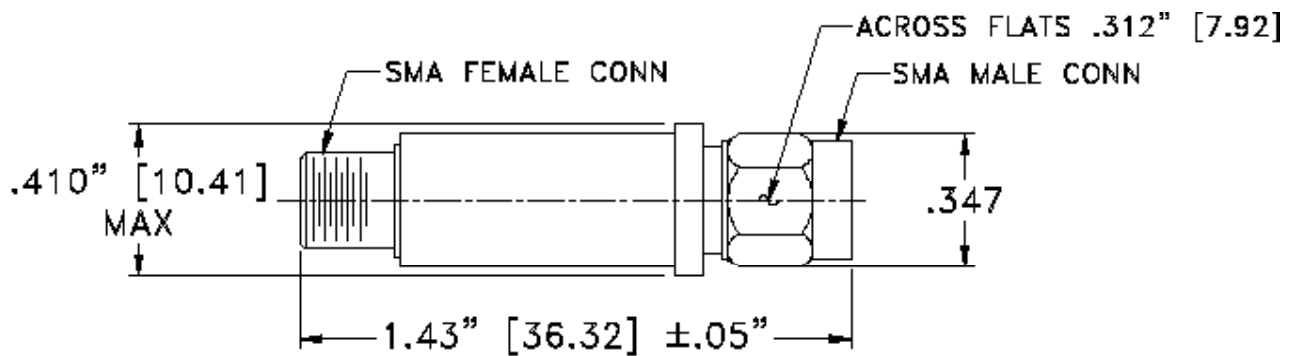

Unit weight: 10.0grams

Dimensions are in inches (mm). Tolerances: 2 Pl. ±.04"; 3 Pl. ±.30"

PRODUCT MARKING*: VHFG-1630+

*Marking may contain other features or characters for internal lot control.



(LTCC) COAXIAL

High Pass Filter

VHFG-1630+

50Ω 1850 to 11000 MHz SMA Male/Female

ADDITIONAL INFORMATION IS AVAILABLE ON OUR DASHBOARD

[CLICK HERE](#)

Performance Data & Graphs	<p>Data</p> <p>Graphs</p> <p>S-Parameter (S2P Files) Data Set (.zip file)</p>
Case Style	FF704
RoHS Status	Compliant
Environmental Ratings	ENV113

NOTES

- A. Performance and quality attributes and conditions not expressly stated in this specification document are intended to be excluded and do not form a part of this specification document.
- B. Electrical specifications and performance data contained in this specification document are based on Mini-Circuits' applicable established test performance criteria and measurement instructions.
- C. The parts covered by this specification document are subject to Mini-Circuits' standard limited warranty and terms and conditions (collectively, "Standard Terms"); Purchasers of this part are entitled to the rights and benefits contained therein. For a full statement of the standard terms and the exclusive rights and remedies thereunder, please visit Mini-Circuits' website at www.minicircuits.com/terms/viewterm.html



Typical Performance Data

FREQ. (MHz)	INSERTION LOSS			INPUT RETURN LOSS			OUTPUT RETURN LOSS		
	(dB)			(dB)			(dB)		
	@-55°C	@+25°C	@+125°C	@-55°C	@+25°C	@+125°C	@-55°C	@+25°C	@+125°C
10	73.42	96.13	80.04	0.03	0.08	0.08	0.01	0.04	0.05
50	68.50	69.35	68.23	0.05	0.11	0.10	0.01	0.09	0.06
100	62.60	62.98	62.98	0.06	0.14	0.13	0.01	0.11	0.08
150	59.66	59.56	59.69	0.08	0.17	0.16	0.03	0.13	0.11
200	57.22	57.35	57.27	0.11	0.19	0.20	0.10	0.19	0.19
250	55.58	55.62	55.50	0.13	0.21	0.22	0.11	0.19	0.21
300	54.16	54.24	54.25	0.15	0.22	0.25	0.16	0.24	0.28
350	53.08	53.15	53.04	0.15	0.24	0.27	0.17	0.25	0.30
400	52.21	52.14	52.15	0.17	0.25	0.29	0.16	0.25	0.29
450	51.33	51.43	51.44	0.17	0.27	0.31	0.16	0.27	0.30
150	59.66	59.56	59.69	0.08	0.17	0.16	0.03	0.13	0.11
200	57.22	57.35	57.27	0.11	0.19	0.20	0.10	0.19	0.19
400	52.21	52.14	52.15	0.17	0.25	0.29	0.16	0.25	0.29
600	49.67	49.75	49.73	0.18	0.29	0.33	0.04	0.20	0.19
800	48.32	48.44	48.36	0.19	0.33	0.38	0.05	0.23	0.23
1000	48.22	48.44	48.57	0.24	0.41	0.47	0.15	0.32	0.37
1100	50.93	51.59	52.22	0.27	0.46	0.53	0.19	0.37	0.45
1200	54.05	50.93	47.70	0.32	0.54	0.64	0.23	0.44	0.54
1300	36.11	34.70	32.90	0.44	0.70	0.85	0.31	0.57	0.70
1400	24.18	22.99	21.39	0.70	1.04	1.33	0.55	0.91	1.17
1500	13.19	12.09	10.74	1.64	2.32	3.19	1.50	2.19	3.05
1600	4.29	4.03	3.82	7.44	9.85	13.09	7.13	9.47	12.52
1630	2.95	2.99	3.02	12.27	15.61	19.46	11.59	14.68	18.07
1850	1.09	1.34	1.50	23.29	24.78	24.83	27.39	34.15	41.42
1980	0.90	1.15	1.30	18.08	17.28	16.41	18.99	17.89	16.93
2000	0.89	1.14	1.29	16.93	16.31	15.59	17.59	16.77	16.03
2200	0.85	1.07	1.18	12.52	12.66	12.77	12.56	12.70	12.78
2500	0.61	0.80	0.88	14.44	15.13	15.61	14.32	15.03	15.42
2800	0.38	0.57	0.64	23.32	25.25	26.39	22.28	24.17	24.87
3000	0.31	0.51	0.58	36.95	33.51	31.33	30.28	31.29	31.32
3200	0.29	0.50	0.57	23.42	22.51	22.00	23.06	22.70	22.45
3400	0.29	0.49	0.57	19.40	19.11	18.69	19.21	19.14	18.74
3600	0.29	0.51	0.59	17.92	17.73	17.29	17.63	17.61	17.03
3800	0.28	0.50	0.58	17.56	17.46	16.86	17.44	17.35	16.64
4000	0.26	0.48	0.57	18.05	17.94	17.22	18.07	17.79	16.95
4200	0.24	0.46	0.55	19.30	19.29	18.53	19.20	18.88	17.89
4400	0.21	0.44	0.52	21.59	21.55	21.02	20.94	20.67	19.56
4600	0.19	0.42	0.50	24.99	25.39	24.94	23.56	23.39	22.24
4800	0.17	0.40	0.48	30.60	32.75	30.95	27.69	27.60	26.36
5000	0.16	0.39	0.47	36.52	34.50	29.74	30.15	28.82	27.81
5200	0.16	0.41	0.49	27.42	25.71	23.72	26.20	24.82	24.22
5400	0.18	0.43	0.53	22.21	21.22	20.15	21.75	20.97	20.57
5500	0.21	0.46	0.56	20.49	19.75	18.96	20.02	19.44	19.14
5600	0.21	0.47	0.56	19.02	18.43	17.92	18.67	18.22	18.05
5800	0.24	0.51	0.60	16.87	16.56	16.48	16.52	16.28	16.39
6000	0.27	0.54	0.64	15.29	15.15	15.37	15.01	14.89	15.22
6200	0.30	0.58	0.67	14.09	14.11	14.52	13.78	13.81	14.22
7000	0.35	0.66	0.77	12.76	12.72	13.03	12.35	12.23	12.24
7200	0.36	0.67	0.80	13.08	12.94	13.06	12.61	12.45	12.15
7400	0.34	0.66	0.79	13.58	13.39	13.30	13.06	12.84	12.28
7600	0.32	0.64	0.79	14.30	14.08	13.75	13.81	13.49	12.73
8000	0.27	0.58	0.72	16.55	16.46	15.71	16.35	15.99	14.91
8400	0.22	0.53	0.65	20.81	21.25	20.38	20.11	20.24	19.34
8800	0.19	0.50	0.63	29.79	30.50	29.22	28.08	28.13	26.62
9000	0.20	0.53	0.66	33.49	28.68	26.70	30.18	26.39	23.74
9400	0.22	0.57	0.74	22.96	20.93	19.78	21.70	19.59	17.91
9600	0.25	0.61	0.78	20.24	18.91	18.24	19.20	17.76	16.62
10000	0.38	0.75	0.91	16.52	16.43	16.85	15.64	15.28	15.33
10500	0.50	0.86	1.01	13.84	14.45	15.40	13.27	13.71	14.39
11000	0.56	0.92	1.08	13.03	13.77	14.40	12.98	13.66	14.21

Typical Performance Data

FREQ. (MHz)	GROUP DELAY		
	(nsec)		
	@-55°C	@+25°C	@+125°C
1850	1.04	1.02	0.98
2000	0.80	0.78	0.76
2500	0.48	0.48	0.48
2800	0.41	0.41	0.41
3000	0.38	0.38	0.38
3600	0.31	0.31	0.31
3800	0.30	0.30	0.30
4000	0.29	0.29	0.29
4600	0.27	0.27	0.27
4800	0.26	0.26	0.27
5000	0.26	0.26	0.26
5200	0.26	0.25	0.26
5600	0.25	0.25	0.25
5800	0.24	0.24	0.25
6000	0.24	0.24	0.24
6400	0.24	0.24	0.24
6800	0.23	0.23	0.24
7000	0.23	0.23	0.24
7200	0.23	0.23	0.23
7400	0.23	0.23	0.23
7600	0.23	0.23	0.23
7800	0.23	0.23	0.24
8000	0.23	0.23	0.24
8200	0.23	0.24	0.24
8400	0.24	0.24	0.24
8600	0.24	0.24	0.24
8800	0.24	0.24	0.24
9000	0.24	0.24	0.24
9200	0.24	0.24	0.24
9400	0.24	0.24	0.24
9600	0.24	0.24	0.24
9800	0.24	0.24	0.25
10000	0.24	0.24	0.25
10200	0.24	0.24	0.24
10400	0.24	0.24	0.25
10600	0.24	0.25	0.25
10700	0.25	0.25	0.26
10800	0.25	0.25	0.26
10900	0.25	0.25	0.26
11000	0.25	0.25	0.26

Typical Performance Curves

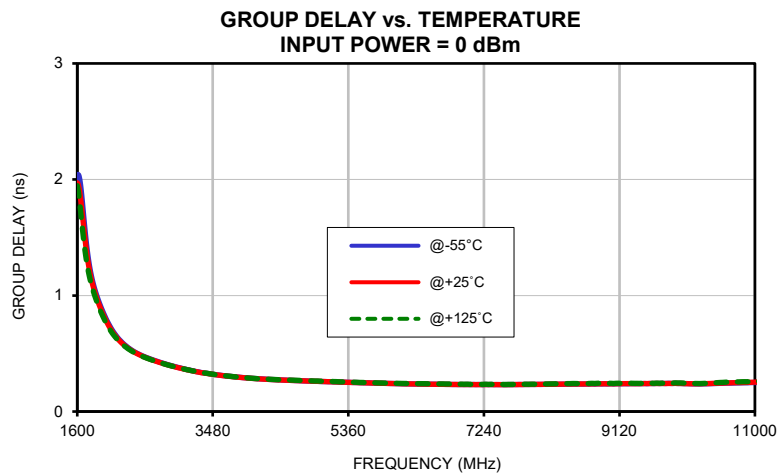
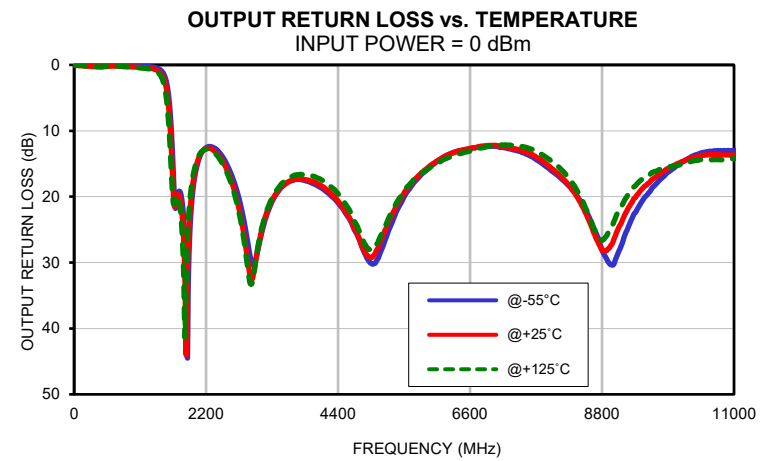
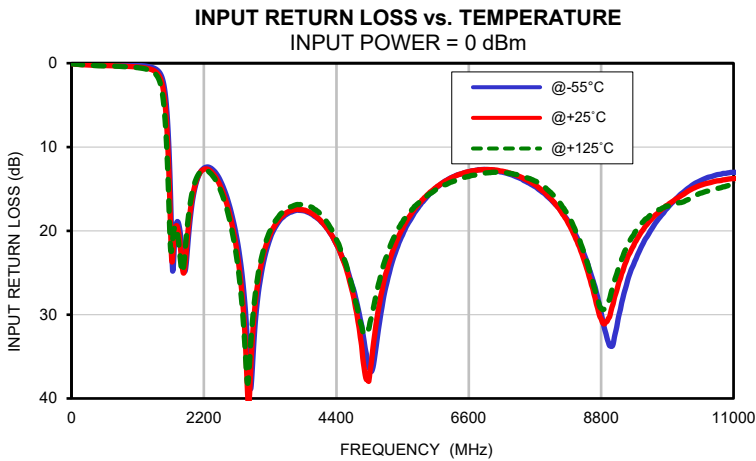
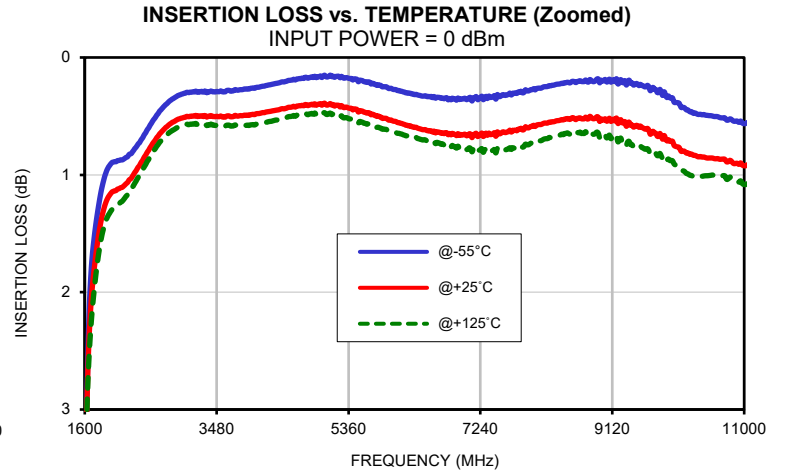
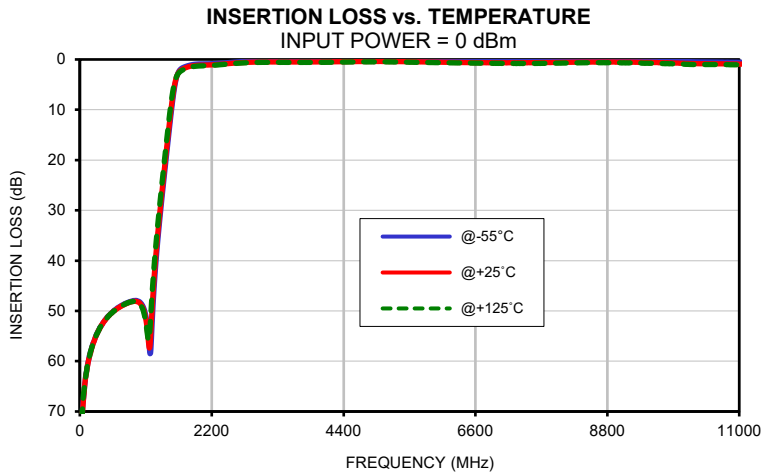

Case Style

FF

FF704

Outline Dimensions

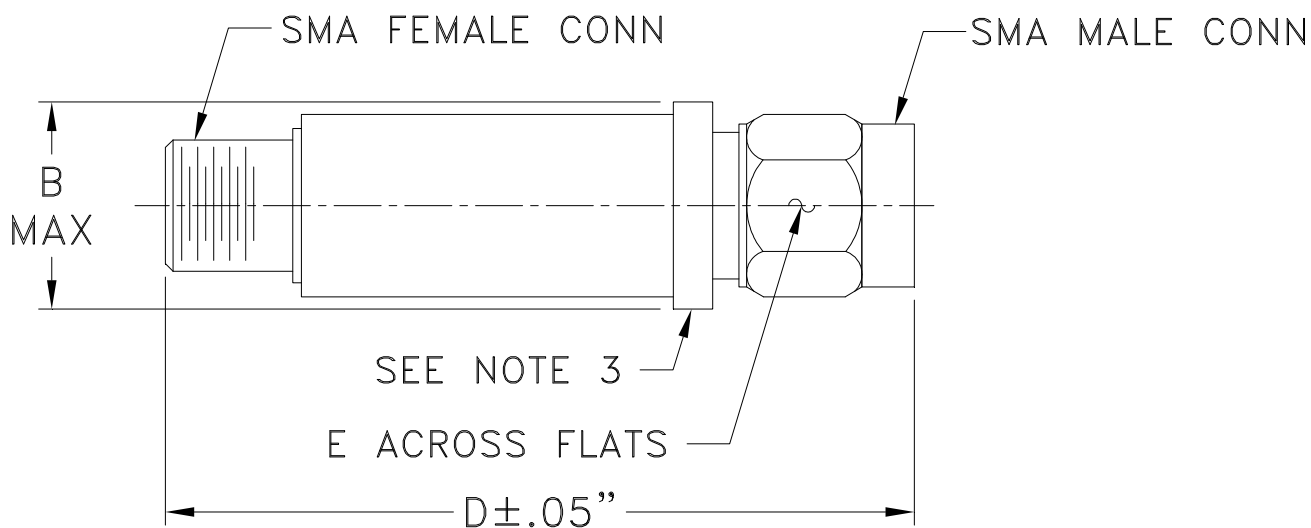

CASE #.	A	B	C	D	E	WT GRAMS
FF704	--	.410 (10.41)	--	1.43 (36.32)	.312 (7.92)	10.0

Dimensions are in inches (mm). Tolerances: 2Pl. ± .04; 3Pl. ± .030

Notes:

1. Case material: Stainless steel.
2. Case finish: Gold plated.
3. Round Flange may have .312 Across Flats in some models.

Mini-Circuits®
ISO 9001 ISO 14001 CERTIFIED

ALL NEW
minicircuits.com

P.O. Box 350166, Brooklyn, New York 11235-0003 (718) 934-4500 Fax (718) 332-4661 For detailed performance specs & shopping online see Mini-Circuits web site



The Design Engineers Search Engine Provides ACTUAL Data Instantly From MINI-CIRCUITS At: www.minicircuits.com

RF/IF MICROWAVE COMPONENTS

All Mini-Circuits products are manufactured under exacting quality assurance and control standards, and are capable of meeting published specifications after being subjected to any or all of the following physical and environmental test.

Specification	Test/Inspection Condition	Reference/Spec
Operating Temperature	-55° to 125° C Ambient Environment	Individual Model Data Sheet
Storage Temperature	-55° to 125° C Ambient Environment	Individual Model Data Sheet
Humidity	90 to 95% RH, 240 hours, 50°C	MIL-STD-202, Method 103, Condition A, Except 50°C and end-point electrical test done within 12 hours
Vibration (High Frequency)	20g peak, 10-2000 Hz, 12 times in each of three perpendicular directions (total 36)	MIL-STD-202, Method 204, Condition D
Mechanical Shock	50g, 11 ms, 1/2-sine, 18 shocks: 3 each direction, each of 3 axes	MIL-STD-202, Method 213, Condition A
Thermal Shock	-55° to 125°C, 100 cycles	MIL-STD-202, Method 107, Condition A-3, Except +125°C