

Microwave Gain Equalizer

VEQY-6-63+

50Ω 6dB DC to 6 GHz

The Big Deal

- Excellent VSWR, 1.2:1 typ.
- Wide bandwidth, DC - 6 GHz
- Connectorized package



Generic photo used for illustration purposes only
CASE STYLE: FF704

+RoHS Compliant

The +Suffix identifies RoHS Compliance. See our web site for RoHS Compliance methodologies and qualifications

Product Overview

Mini-Circuits' VEQY-6-63+ is an absorptive Gain Equalizer fabricated using highly repetitive GaAs IPD* MMIC process incorporating resistors, capacitors and inductors having negative insertion loss slope. VEQY-6-63+ has a nominal attenuation slope of 6 dB.

Key Features

Feature	Advantages
Negative Insertion Loss Slope vs. Frequency	Useful for compensating negative gain slope of amplifiers, receivers, transmitters to achieve flat gain versus frequency.
Wideband operation, DC to 6 GHz	Supports a wide array of applications including wireless cellular, microwave communications, satellite, defense and aerospace, medical broadband and optic applications.
Excellent Power Handling Capability 32 dBm	Enables its use at the output of a variety of amplifiers
Connectorized package	The connectorized package is easy to interface with other devices and well suited for test setups.

*GaAs IPD (Gallium Arsenide Integrated Passive Device)

Notes

- A. Performance and quality attributes and conditions not expressly stated in this specification document are intended to be excluded and do not form a part of this specification document.
B. Electrical specifications and performance data contained in this specification document are based on Mini-Circuit's applicable established test performance criteria and measurement instructions.
C. The parts covered by this specification document are subject to Mini-Circuits standard limited warranty and terms and conditions (collectively, "Standard Terms"); Purchasers of this part are entitled to the rights and benefits contained therein. For a full statement of the Standard Terms and the exclusive rights and remedies thereunder, please visit Mini-Circuits' website at www.minicircuits.com/MCLStore/terms.jsp



Gain Equalizer

50Ω 6dB DC to 6 GHz

VEQY-6-63+



Generic photo used for illustration purposes only
CASE STYLE: FF704

Connectors	Model
SMA	VEQY-6-63+

Features

- 6 dB Slope
- Wide Bandwidth, DC-6 GHz
- Excellent VSWR, 1.2:1 typ.
- Connectorized package

Applications

- Communications
- Radar
- Defense

Simplified schematic

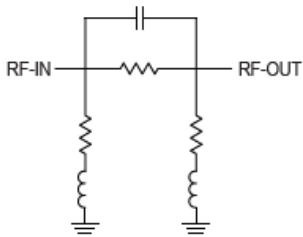

Electrical Specifications at 25°C

Parameter	Condition (GHz)	Min.	Typ.	Max.	Units
Frequency Range		DC	—	6	GHz
Insertion Loss	0.01	6.6	7.0	7.4	dB
	1	—	6.1	—	
	2	—	4.2	—	
	3	2.2	2.6	3.0	
	4	—	1.5	—	
	5	—	0.8	—	
	6	0.2	0.6	1.1	
VSWR	0.01 - 1	—	1.08	—	:1
	1 - 2	—	1.17	—	
	2 - 3	—	1.2	—	
	3 - 4	—	1.2	—	
	4 - 5	—	1.11	—	
	5 - 6	—	1.12	—	

Absolute Maximum Ratings¹

Parameter	Ratings
Operating Temperature	-40°C to 85°C
Storage Temperature	-55°C to 100°C
RF Power	32 dBm

¹ Permanent damage may occur if any of these limits are exceeded

ESD rating

Human Body Model (HBM): Class 2 (Pass 2000V) in accordance with ANSI/ESD STM 5.1 - 2001 Machine.

Typical Performance Data at 25°C

Frequency (MHz)	Insertion Loss (dB)	VSWR (:1)	
		Input	Output
10	6.96	1.01	1.01
50	6.97	1.01	1.01
100	6.98	1.01	1.01
500	6.77	1.04	1.04
1000	6.08	1.08	1.08
1300	5.55	1.10	1.09
1500	5.17	1.12	1.10
1800	4.60	1.15	1.11
2000	4.23	1.17	1.11
2500	3.36	1.20	1.11
2800	2.90	1.20	1.11
3000	2.61	1.20	1.11
3500	1.98	1.17	1.09
4000	1.46	1.11	1.08
4500	1.07	1.07	1.07
5000	0.79	1.08	1.09
5500	0.62	1.12	1.11
6000	0.56	1.12	1.12

Typical Frequency Response

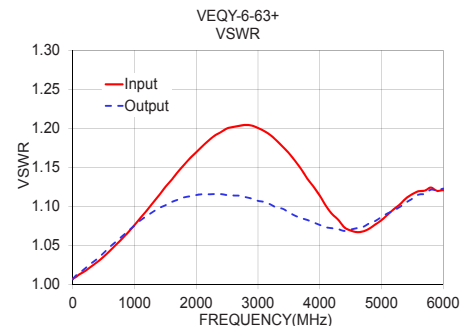
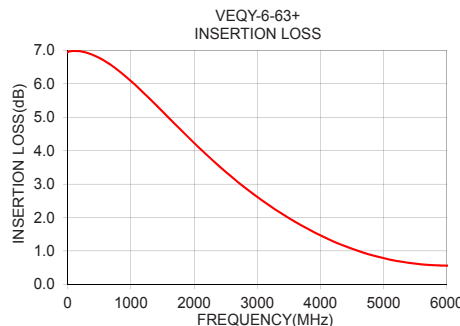
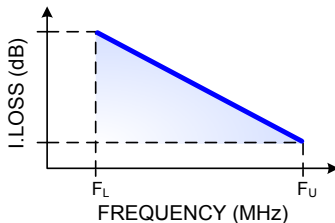

+RoHS Compliant

The +Suffix identifies RoHS Compliance. See our web site for RoHS Compliance methodologies and qualifications

Notes

- Performance and quality attributes and conditions not expressly stated in this specification document are intended to be excluded and do not form a part of this specification document.
- Electrical specifications and performance data contained in this specification document are based on Mini-Circuit's applicable established test performance criteria and measurement instructions.
- The parts covered by this specification document are subject to Mini-Circuits standard limited warranty and terms and conditions (collectively, "Standard Terms"); Purchasers of this part are entitled to the rights and benefits contained therein. For a full statement of the Standard Terms and the exclusive rights and remedies thereunder, please visit Mini-Circuits' website at www.minicircuits.com/MCLStore/terms.jsp



Coaxial Connections

PORT - 1	SMA-Female
PORT - 2	SMA-Male

Outline Drawing

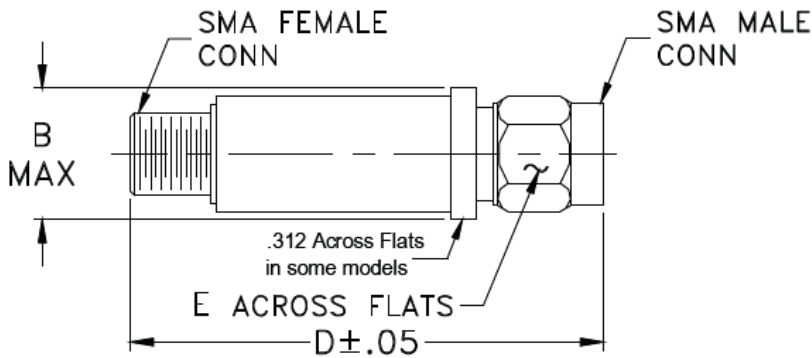

Outline Dimensions ($\frac{\text{inch}}{\text{mm}}$)

B	D	E	wt.
.410	1.43	.312	grams
10.41	36.32	7.92	10

Note: Please refer to case style drawing for details

Notes

- A. Performance and quality attributes and conditions not expressly stated in this specification document are intended to be excluded and do not form a part of this specification document.
- B. Electrical specifications and performance data contained in this specification document are based on Mini-Circuit's applicable established test performance criteria and measurement instructions.
- C. The parts covered by this specification document are subject to Mini-Circuits standard limited warranty and terms and conditions (collectively, "Standard Terms"); Purchasers of this part are entitled to the rights and benefits contained therein. For a full statement of the Standard Terms and the exclusive rights and remedies thereunder, please visit Mini-Circuits' website at www.minicircuits.com/MCLStore/terms.jsp



Typical Performance Data

FREQ. (MHz)	INSERTION LOSS			INPUT RETURN LOSS			OUTPUT RETURN LOSS		
	(dB)			(dB)			(dB)		
	@-40°C	@+25°C	@+85°C	@-40°C	@+25°C	@+85°C	@-40°C	@+25°C	@+85°C
1	6.94	6.94	6.93	47.20	48.82	49.97	47.94	49.90	51.33
10	6.96	6.96	6.95	46.16	47.93	49.62	46.53	48.26	49.79
50	6.96	6.97	6.97	42.75	46.61	47.79	40.28	44.95	46.87
100	6.97	6.98	6.98	39.20	44.08	47.29	36.98	43.11	53.55
200	6.95	6.97	6.97	37.28	41.38	45.32	38.11	39.85	40.46
300	6.90	6.93	6.93	38.86	38.84	38.16	46.81	37.49	34.89
400	6.82	6.86	6.87	41.50	36.94	35.15	37.17	35.77	33.95
500	6.73	6.77	6.79	36.64	35.16	33.34	33.99	34.08	32.86
600	6.62	6.66	6.68	33.88	33.53	31.99	32.73	32.58	31.19
700	6.49	6.54	6.56	32.30	32.11	30.77	30.95	31.48	30.51
800	6.35	6.40	6.42	30.93	30.90	29.82	29.89	30.46	30.28
900	6.19	6.24	6.27	29.77	29.78	29.01	29.75	29.57	29.67
1000	6.02	6.08	6.11	29.03	28.72	28.13	29.68	28.79	29.14
1100	5.85	5.91	5.94	28.29	27.73	27.33	28.59	28.06	28.68
1200	5.67	5.73	5.76	27.43	26.88	26.67	27.87	27.53	28.08
1300	5.48	5.55	5.58	26.67	26.06	25.97	27.57	27.04	27.52
1400	5.30	5.36	5.40	26.05	25.33	25.36	26.54	26.62	26.99
1500	5.11	5.17	5.21	25.20	24.61	24.83	25.97	26.33	26.62
1600	4.91	4.98	5.02	24.38	24.05	24.39	25.66	26.00	26.14
1700	4.72	4.79	4.83	23.68	23.46	23.87	24.97	25.77	25.78
1800	4.53	4.60	4.64	23.21	22.97	23.41	24.56	25.55	25.55
1900	4.34	4.41	4.46	22.75	22.52	22.98	24.66	25.44	25.42
2000	4.15	4.23	4.28	22.19	22.15	22.61	24.74	25.33	25.31
2100	3.97	4.05	4.10	21.60	21.79	22.26	24.82	25.25	25.30
2200	3.79	3.87	3.92	21.17	21.48	21.91	24.95	25.26	25.37
2300	3.62	3.70	3.75	20.83	21.20	21.59	25.27	25.24	25.49
2400	3.45	3.53	3.59	20.52	21.02	21.39	25.71	25.24	25.57
2500	3.27	3.36	3.42	20.20	20.83	21.22	26.01	25.33	25.67
2600	3.12	3.21	3.26	20.07	20.76	21.06	26.15	25.37	25.91
2700	2.95	3.05	3.11	20.11	20.70	20.95	25.95	25.39	25.91
2800	2.80	2.90	2.96	20.24	20.66	20.95	25.65	25.52	26.04
2900	2.66	2.75	2.82	20.39	20.69	20.97	25.43	25.66	26.32
3000	2.52	2.61	2.68	20.65	20.81	21.01	25.11	25.88	26.44
3100	2.38	2.48	2.55	21.00	20.97	21.17	24.81	25.99	26.57
3200	2.25	2.35	2.42	21.24	21.18	21.43	24.94	26.24	27.02
3300	2.11	2.22	2.29	21.35	21.47	21.66	25.37	26.57	27.30
3400	1.99	2.10	2.18	21.55	21.82	21.96	25.67	26.70	27.42
3500	1.87	1.98	2.06	21.90	22.21	22.46	26.08	27.11	28.13
3600	1.76	1.87	1.95	22.15	22.69	22.97	26.55	27.50	28.60
3700	1.65	1.76	1.84	22.40	23.25	23.46	27.17	27.80	29.19
3800	1.54	1.66	1.74	22.95	23.96	24.22	27.21	28.04	29.89
3900	1.44	1.56	1.64	23.40	24.60	25.06	27.18	28.37	30.39
4000	1.34	1.46	1.55	23.88	25.37	25.89	27.48	28.70	31.13
4100	1.24	1.38	1.46	24.78	26.39	27.18	27.20	29.04	31.78
4200	1.15	1.29	1.38	25.34	27.30	28.71	26.94	29.18	31.79
4300	1.07	1.21	1.30	25.40	28.01	30.24	27.23	29.33	32.11
4400	0.99	1.14	1.23	26.09	29.06	32.26	27.73	29.60	32.20
4500	0.92	1.07	1.16	26.68	29.53	33.45	27.38	29.39	31.46
4600	0.85	1.00	1.10	26.86	29.78	33.67	27.13	29.18	31.10
4700	0.78	0.94	1.04	27.01	29.68	32.43	27.45	29.00	30.56
4800	0.72	0.88	0.99	27.77	29.26	30.47	27.99	28.50	29.49
4900	0.67	0.83	0.94	28.71	28.65	28.76	28.40	28.17	28.84
5000	0.62	0.79	0.90	29.14	28.07	27.55	28.34	27.67	27.98
5100	0.57	0.74	0.86	29.55	27.38	26.28	28.76	27.22	26.96
5200	0.52	0.70	0.83	30.34	26.76	25.22	29.75	26.90	26.30
5300	0.49	0.67	0.80	30.19	26.23	24.61	29.75	26.50	25.72
5400	0.45	0.64	0.77	29.04	25.63	24.22	29.04	26.04	25.09
5800	0.37	0.57	0.71	26.98	24.67	23.26	28.77	24.85	23.27
5900	0.35	0.56	0.71	27.89	24.96	23.37	30.89	24.90	23.24
6000	0.35	0.56	0.71	27.29	24.89	23.54	30.80	24.76	23.01

Typical Performance Curves

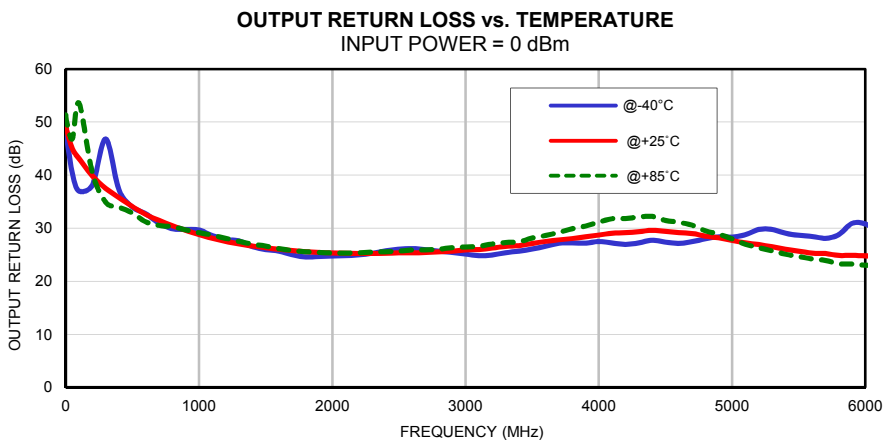
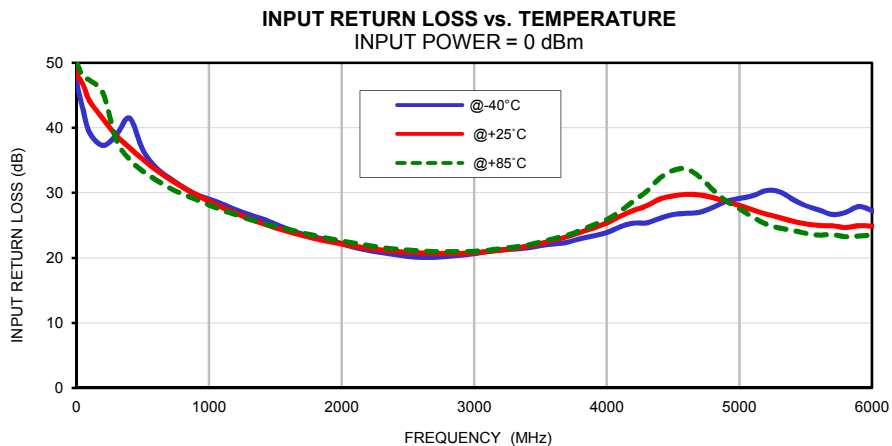
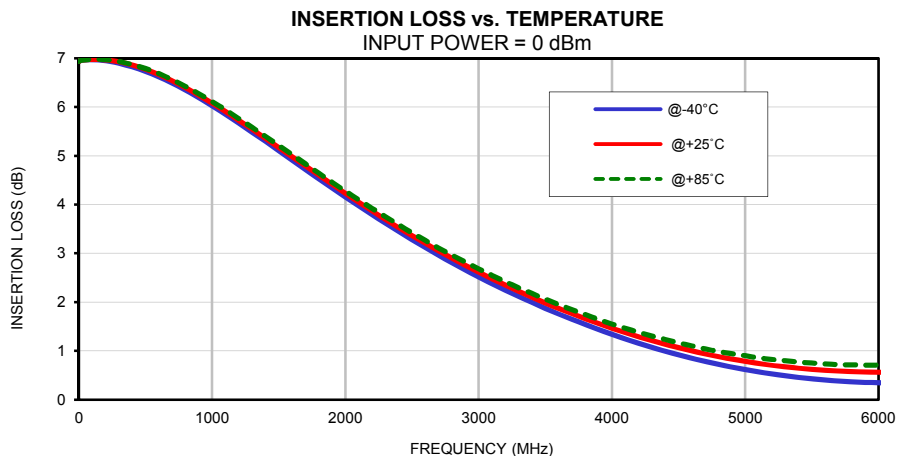

Case Style

FF

FF704

Outline Dimensions

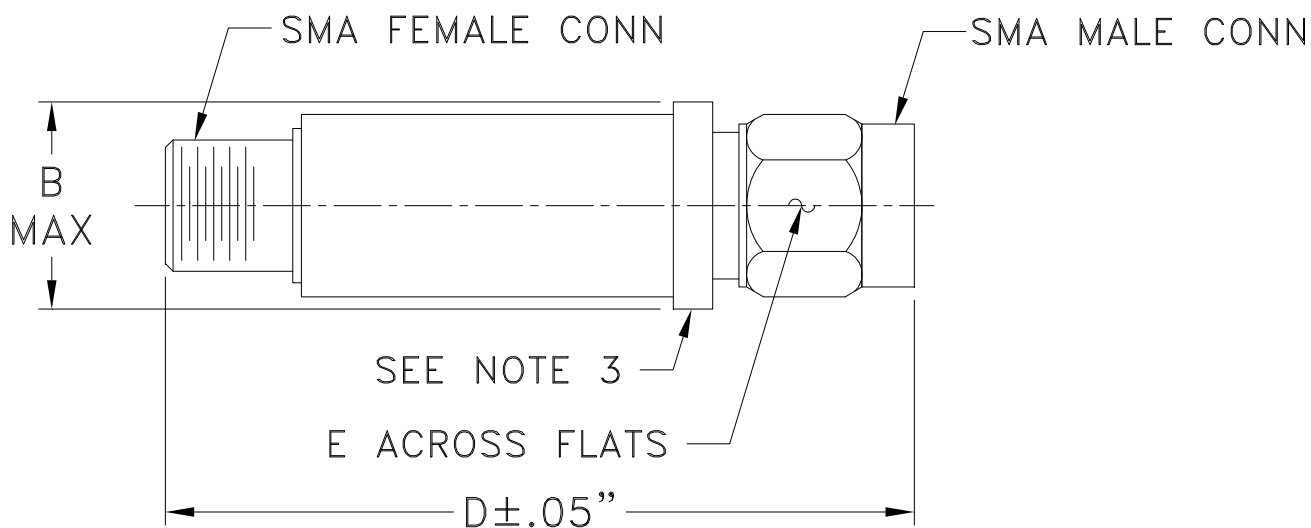

CASE #.	A	B	C	D	E	WT GRAMS
FF704	--	.410 (10.41)	--	1.43 (36.32)	.312 (7.92)	10.0

Dimensions are in inches (mm). Tolerances: 2Pl. ± .04; 3Pl. ± .030

Notes:

1. Case material: Stainless steel.
2. Case finish: Gold plated.
3. Round Flange may have .312 Across Flats in some models.

Mini-Circuits®
ISO 9001 ISO 14001 CERTIFIED

ALL NEW
minicircuits.com

P.O. Box 350166, Brooklyn, New York 11235-0003 (718) 934-4500 Fax (718) 332-4661 For detailed performance specs & shopping online see Mini-Circuits web site



The Design Engineers Search Engine Provides ACTUAL Data Instantly From MINI-CIRCUITS At: www.minicircuits.com

RF/IF MICROWAVE COMPONENTS



All Mini-Circuits products are manufactured under exacting quality assurance and control standards, and are capable of meeting published specifications after being subjected to any or all of the following physical and environmental test.

Specification	Test/Inspection Condition	Reference/Spec
Operating Temperature	-40° to 85° C Ambient Environment	Individual Model Data Sheet
Storage Temperature	-55° to 100° C Ambient Environment	Individual Model Data Sheet
Thermal Shock	-55° to 100°C, 100 cycles	MIL-STD-202, Method 107, Condition A-3, except +100°C