



USB

Solid-State Switch

USB-1SP2T-A44

50Ω 0.1 to 43.5 GHz SP2T 2.92 mm female

THE BIG DEAL

- Super wide bandwidth, solid-state design
- High isolation, 60 dB @ 43.5 GHz
- USB control and automation
- Daisy-chain control of up to 25 modules

APPLICATIONS

- RF & millimeter wave signal routing / switch matrices
- Satellite communications up to Ka band
- Military radio, radar & electronic warfare
- Microwave radio / cellular infrastructure
- Test & measurement systems



Generic photo used for illustration purposes only

PRODUCT OVERVIEW

Mini-Circuits' USB-1SP2T-A44 is a fast switching solid-state SP2T covering an ultra-wide bandwidth, from 0.1 to 43.5 GHz. The solid-state design features an impressive combination of high isolation, low insertion loss and good linearity across the entire band, with internal terminations on ports 1 and 2.

The switch is supplied in a low profile package (3.7" x 1.7" x 0.6") with 3 precision 2.92 mm RF connectors, a USB type C for power and unit control and 2 serial data bus connections for daisy-chaining with additional switch modules.

Full software support is provided, including our user-friendly GUI application for Windows and a full API with programming instructions for Windows and Linux environments.

KEY FEATURES

Feature	Advantages
Fast switching sequences	Program automated switching sequences to run with extremely fast transitions and no external control.
High performance	Solid-state design combining high isolation with low insertion loss from 0.1 to 43.5 GHz.
Dynamic daisy-chain control	Control up to 25 switches through a single USB interface.
USB control	USB HID and Ethernet interfaces provides easy compatibility with a wide range of software setups and programming environments.
Full software support	User friendly Windows GUI (graphical user interface) allows manual control straight out of the box, while the comprehensive API (application programming interface) with examples and instructions allows easy automation in most programming environments.

Trademarks:

Windows is a registered trademark of Microsoft Corporation in the United States and other countries ; Linux is a registered trademark of Linus Torvalds. Neither Mini-Circuits nor the Mini-Circuits products are affiliated with or endorsed by the owners of the referenced trademarks. Mini-Circuits and the Mini-Circuits logo are registered trademarks of Scientific Components Corporation.





USB

Solid-State Switch

USB-1SP2T-A44



50Ω 0.1 to 43.5 GHz SP2T 2.92 mm female

ELECTRICAL SPECIFICATIONS AT -10 TO +60°C

Parameter	Ports	Condition (GHz)	Min.	Typ.	Max.	Unit
Frequency Range	-	-	0.1	-	43.5	GHz
Insertion Loss	COM to any active port	0.1 - 18	-	1.5	3.0	dB
		18 - 26	-	2.0	3.5	
		26 - 35	-	2.5	4.0	
		35 - 40	-	3.0	5.0	
		40 - 43.5	-	4.0	6.0	
Isolation	Between ports 1 & 2	0.1 - 18	53	65	-	dB
		18 - 26	45	60	-	
		26 - 35	45	56	-	
		35 - 40	43	52	-	
		40 - 43.5	41	47	-	
	COM to any terminated port (active states)	0.1 - 18	53	65	-	
		18 - 26	45	55	-	
		26 - 35	45	52	-	
		35 - 40	42	50	-	
		40 - 43.5	39	46	-	
	COM to any terminated port (including disconnected state)	0.1 - 18	50	65	-	
		18 - 26	43	52	-	
		26 - 35	43	51	-	
		35 - 40	40	48	-	
		40 - 43.5	37	48	-	
Return Loss	COM port ¹ (in all active states)	0.1 - 18	11.5	21	-	dB
		18 - 26	11	16	-	
		26 - 35	10	16	-	
		35 - 40	10	16	-	
		40 - 43.5	6.5	11	-	
	Any port connected to COM	0.1 - 18	13	21	-	
		18 - 26	12	16	-	
		26 - 35	12	17	-	
		35 - 40	10	16	-	
		40 - 43.5	6.5	11	-	
	Any terminated port	0.1 - 18	15	21	-	
		18 - 26	15	20	-	
		26 - 35	12	17	-	
		35 - 40	11	17	-	
		40 - 43.5	8.5	13	-	

1. COM port is reflective in disconnected state.



**USB**

Solid-State Switch

USB-1SP2T-A44

50Ω 0.1 to 43.5 GHz SP2T 2.92 mm female

ELECTRICAL SPECIFICATIONS AT -10 TO +60°C (CONTINUED)

Parameter	Ports	Condition (GHz)	Min.	Typ.	Max.	Unit
Power Input @1 dB Compression	COM to any active port	0.1 - 43.5	-	+27	-	dBm
IP3 ²	COM to any active port	0.1 - 43.5	-	+50	-	dBm
Transition Time ³	-	-	-	600	-	ns
Minimum Dwell Time ⁴	High-speed mode	-	-	20	-	μs
Switching Time (USB) ⁵	-	-	-	2	-	ms
Supply Voltage (Vcc)	USB port	-	4.75	5.00	5.25	V _{DC}
Supply Current (Icc) ⁶		-	-	100	150	mA
Current Pass-Through ⁷	-	-	-	-	500	mA
Operating RF Input Power	Through path (Hot & Cold switching)	0.1 - 40	-	-	+24	dBm
		40 - 43.5	-	-	+23	
	COM to any port	0.1 - 40	-	-	+24	
		40 - 43.5	-	-	+23	
	Into termination	0.1 - 40	-	-	+24	
		40 - 43.5	-	-	+23	

2. IP3 is tested with 1 MHz span between signals, +12 dBm per tone.

3. Transition time spec represents the time that the RF signal paths are interrupted during switching and thus is specified without communication delays.

4. Minimum Dwell Time is the shortest time that can be achieved between 2 switch transitions when programming an automated switch sequence.

5. Switching Time (USB) is the time from issuing a single software command via USB to the switch state changing. The most significant factor is the host PC, influenced by CPU load and USB protocol. The time shown is an estimate for a medium CPU load and USB 2.0 connection.

6. Supply Current draw for a single unit with no slave units.

7. Current Pass-Through is the maximum supply current handling of a unit with slave modules attached. If controlling a large number of slave modules additional power supplies should be included to ensure this limit is not exceeded.

ABSOLUTE MAXIMUM RATINGS⁸

Operating Temperature		-10°C to +60°C
Storage Temperature		-20°C to +60°C
DC Supply Voltage Max		6V
DC Voltage @ RF ports ⁹		0V
RF Input Power	0.1 - 40 GHz	+25 dBm
	40 - 43.5 GHz	+24 dBm
RF Input Power with DC Supply disconnected		+20 dBm

8. Permanent damage may occur if any of these limits are exceeded. Operating in the range between operating power limits and absolute maximum ratings for extended periods of time may result in reduced life and reliability.

9. If your signal has a DC component use a DC block such as [BLK-K44+](#) to prevent damage to the switch.





USB

Solid-State Switch

USB-1SP2T-A44

Mini-Circuits

50Ω 0.1 to 43.5 GHz SP2T 2.92 mm female

TYPICAL PERFORMANCE GRAPHS

Insertion Loss over Temperature (1 Active)

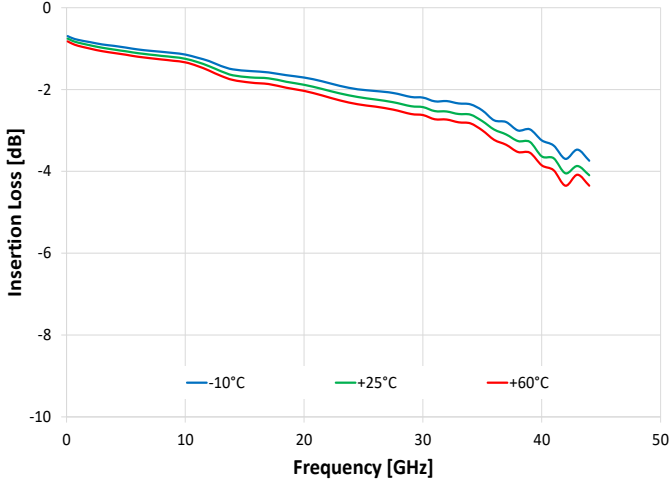

Insertion Loss 1 - 2 Active

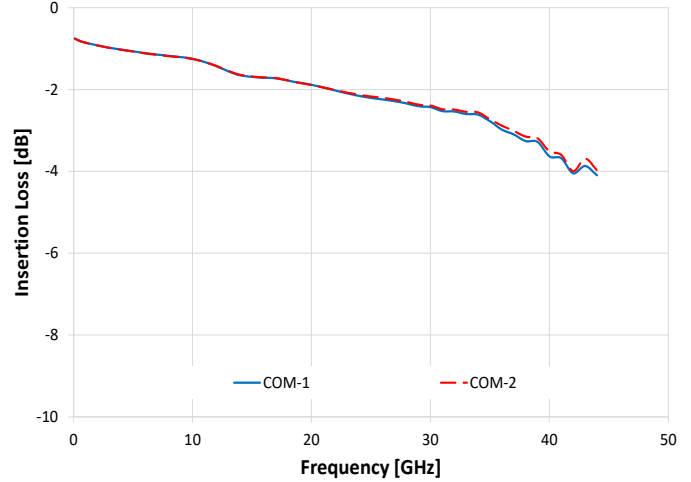

Isolation Com to 1 (2 Active)

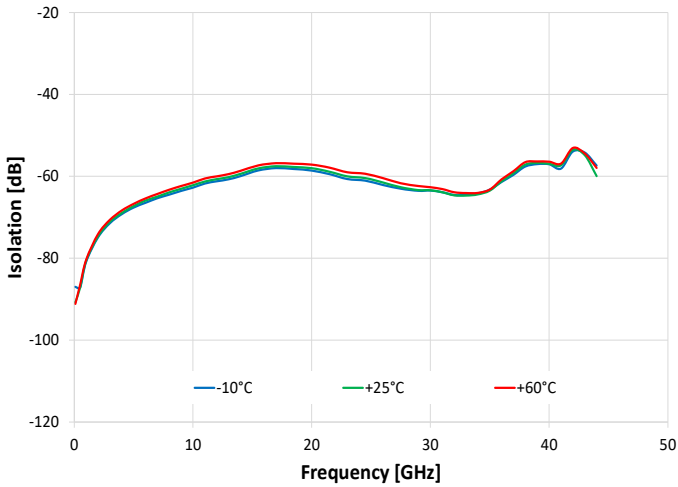

Isolation Com to 2 (1 Active)

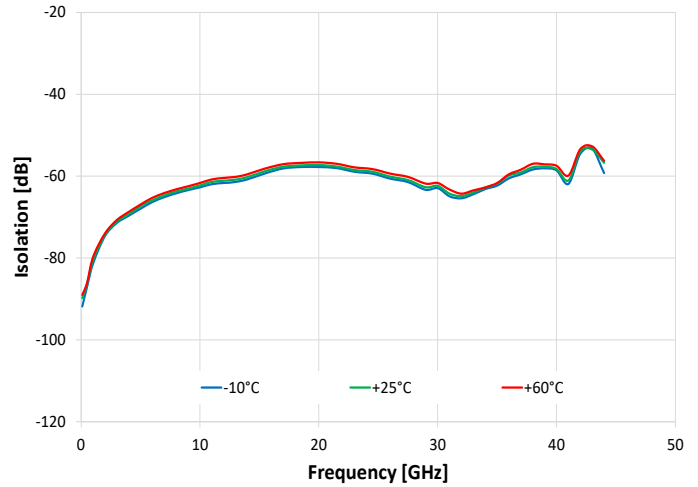

Isolation 1 to 2 (1 Active)

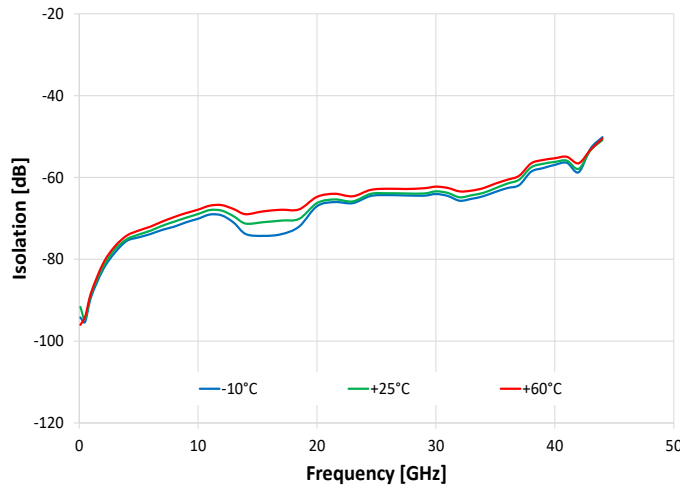



USB

Solid-State Switch

USB-1SP2T-A44

Mini-Circuits

50Ω 0.1 to 43.5 GHz SP2T 2.92 mm female

TYPICAL PERFORMANCE GRAPHS (CONTINUED)

Return Loss @ COM over Temperature (1 Active)

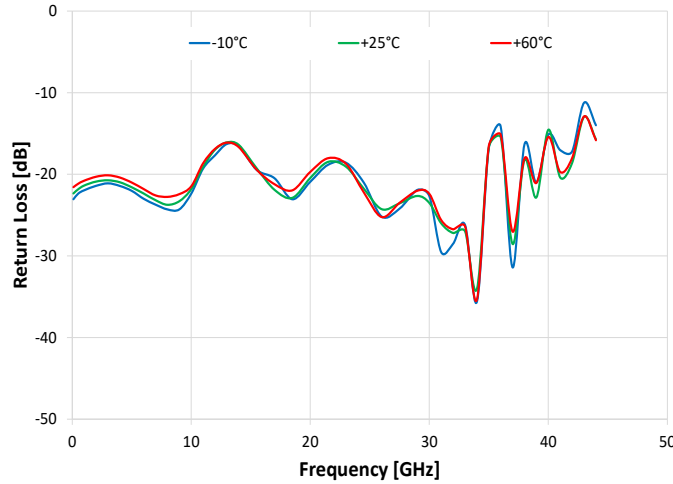

Return Loss @ 1 over Temperature (1 Active)

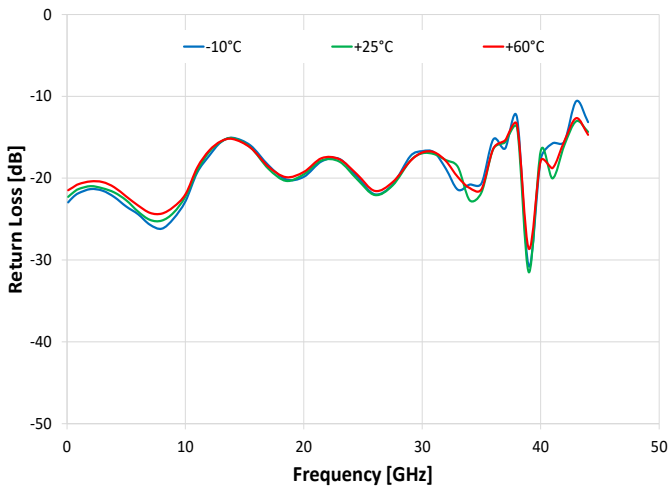

Return Loss @ 1 over Temperature (1 Terminated)

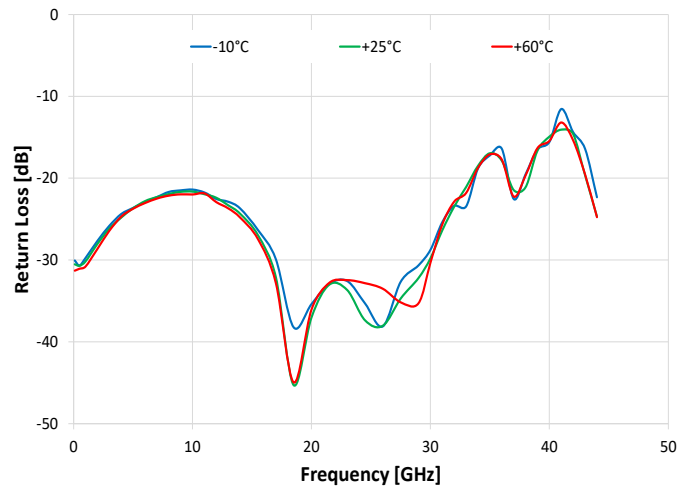

Return Loss @ 2 over Temperature (2 Active)

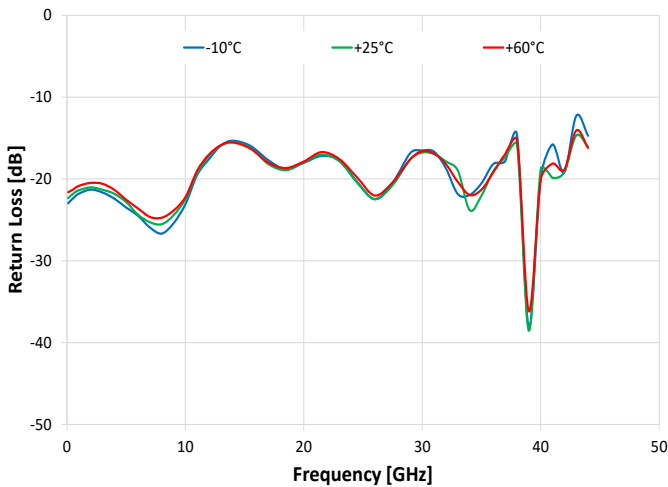

Return Loss @ 2 over Temperature (2 Terminated)

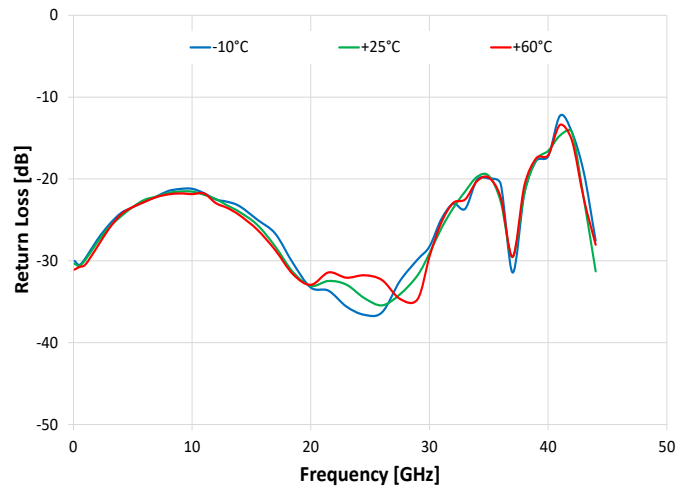

**CONTROL INTERFACES**

USB Control	Supported Protocols	HID (Human Interface Device) - High-speed
	Min Communication Time ¹⁰	400 μs typ (full transmit/receive cycle)

10. USB Min Communication Time is based on the polling interval of the USB HID protocol (125 μs polling interval, 64 bytes per packet), medium CPU load and no other high speed USB devices using the USB bus.

SOFTWARE & DOCUMENTATION

Mini-Circuits' full software and support package including user guide, Windows GUI, API, programming manual and examples can be downloaded free of charge (refer to the last page for the download path).

A comprehensive set of software control options is provided:

- GUI for Windows – Simple software interface for control via USB.
- Programming / automation via USB:
 - DLL files provide a full API for Windows with a set of intuitive functions which can be implemented in any programming environment supporting .Net Framework or ActiveX.
 - Direct USB programming is possible in any other environment (not supporting .Net or ActiveX).

Please contact testsolutions@minicircuits.com for support.

MINIMUM SYSTEM REQUIREMENTS

GUI	Windows 7 or later
USB API DLL	Windows 7 or later and programming environment with ActiveX or .NET support
USB Direct Programming	Linux, Windows 7 or later
Daisy-Chain Dynamic Addressing	An additional Mini-Circuits model supporting dynamic addressing
Hardware	Intel i3 (or equivalent) or later



USB

Solid-State Switch

USB-1SP2T-A44



50Ω 0.1 to 43.5 GHz SP2T 2.92 mm female

GRAPHICAL USER INTERFACE (GUI) FOR WINDOWS - KEY FEATURES

- Connect via USB
- Run GUI in "demo mode" to evaluate software without a hardware connection

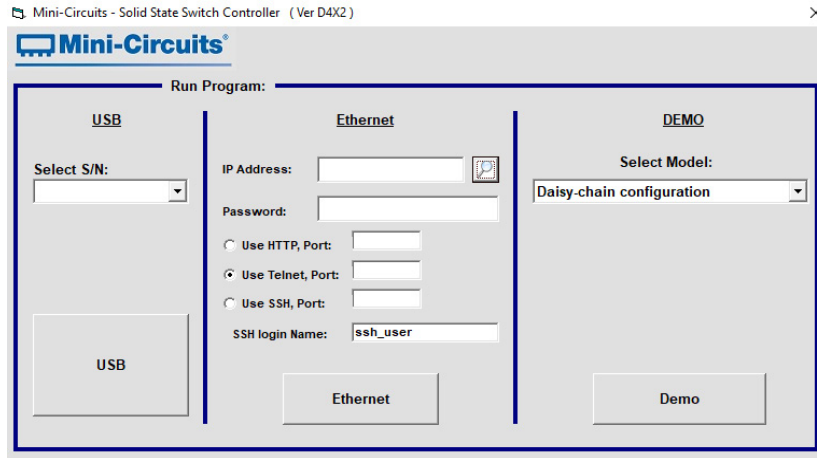

- View and set switch states at the click of a button
- Configure and run timed switching sequences

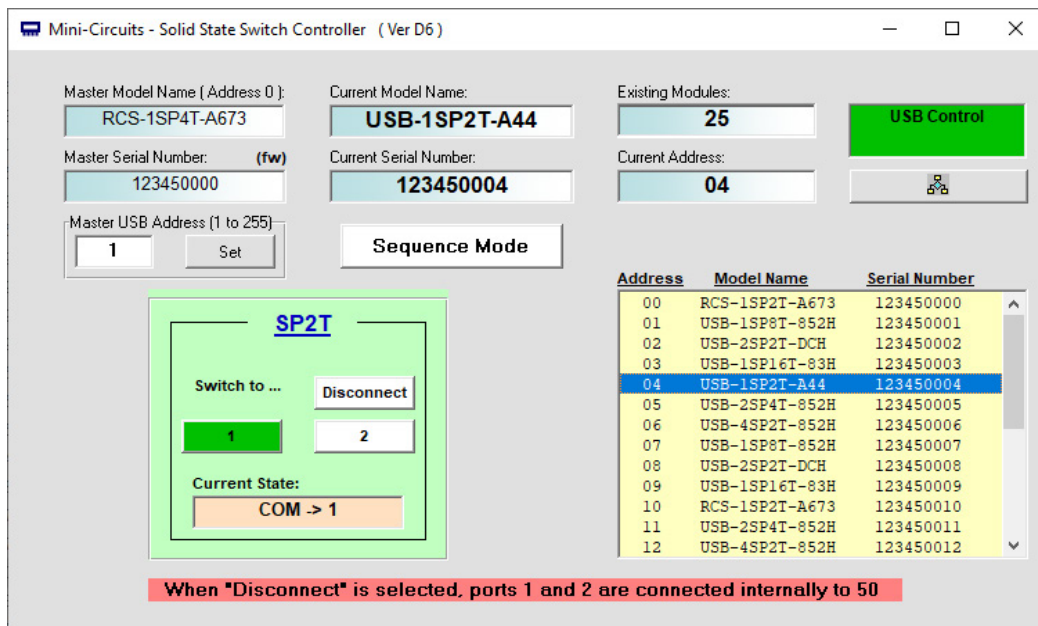



USB

Solid-State Switch

USB-1SP2T-A44

Mini-Circuits

50Ω 0.1 to 43.5 GHz SP2T 2.92 mm female

CONNECTING MULTIPLE MODULES (DAISY CHAIN)

The model is designed to connect up to 25 modules in series (daisy chain) using dynamic addressing, meaning there is no need to specifically set the address of the modules. The addresses will be set automatically as part of establishing the communications with the computer. The module connected to the computer's USB port will be assigned address 0 (master), the first module connected to it will get address 1 (slave) and subsequent modules incrementing up to address 24 (slave).

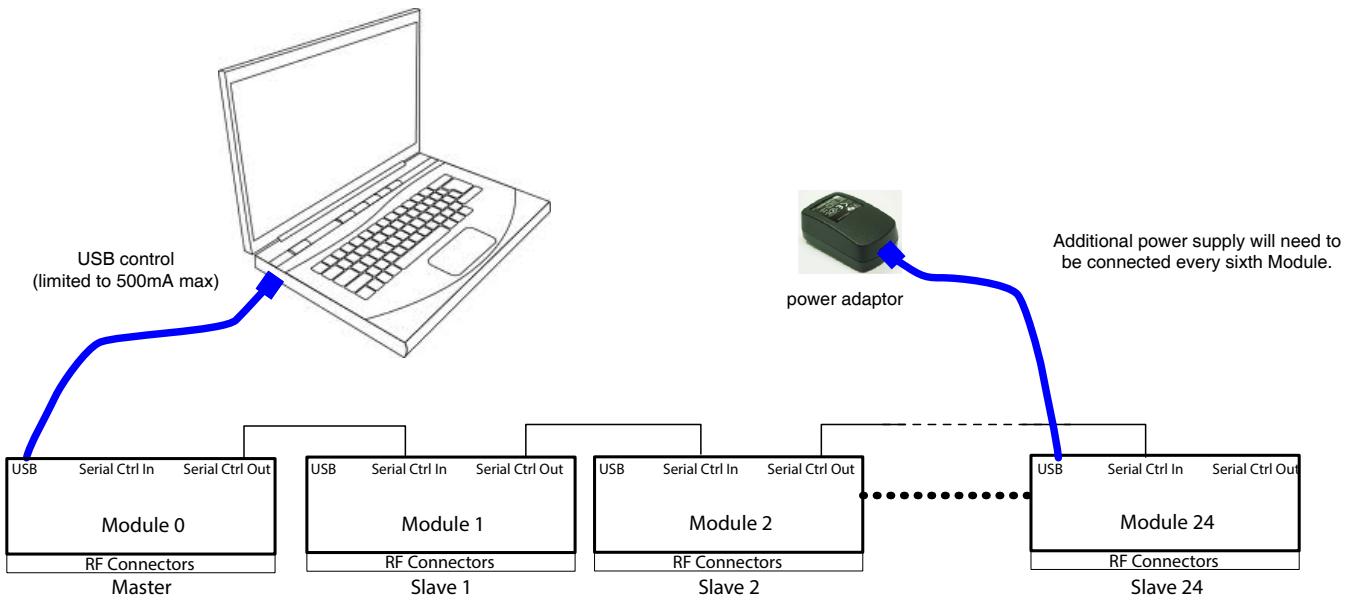

Connections between modules will be made using the serial in/out ports with the module connected to the PC act as a master and all other as slave modules. All control will be through the master module (address 0) which is the only one communicating with the PC. Serial control out port of each module should be connected to the serial control in port of the next module.

Power will be supplied from the PC via the master module up to a maximum of 500 mA. Generally, additional power supply will be needed to keep total current below 500 mA. All power supplies should be connected to the module via the module's USB port. Connecting an additional power supply will automatically cut off power draw from the serial control in port for that module.

The serial master/slave bus allows connecting modules of different types to the same daisy chain as long as all support Mini-Circuits Dynamic addressing setup. To add a new module to the setup, simply connect the module and refresh the address listing, no need to reset any of the existing modules or assign addresses manually.

Note: Different module types may have different current consumption which will change the number of units which can be connected before an additional power supply is needed. For example, if connecting units with a current consumption of 100 mA each, additional power supply is recommended every sixth module. If using units with current consumption of 50 mA additional power supply is recommended every eleventh module.



USB

Solid-State Switch

USB-1SP2T-A44

Mini-Circuits

50Ω 0.1 to 43.5 GHz SP2T 2.92 mm female

BLOCK DIAGRAM

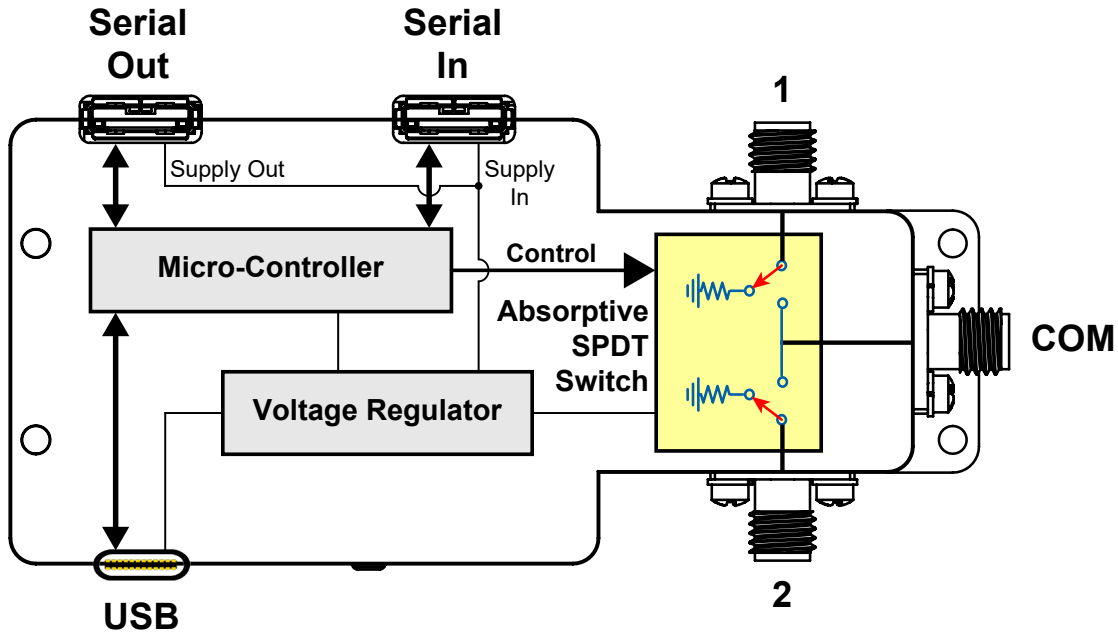

SWITCH STATE TABLE

State	Switch Path
0	All ports disconnected (COM open, 1-2 terminated)
1	Com to 1
2	Com to 2

CONNECTIONS

Port Name	Connector Type
RF Ports (COM, 1 & 2)	2.92 mm Female
USB	USB Type C Receptacle
Serial In (digital control 2 port)	Digital Snap-Fit Connector ¹¹
Serial Out (digital control 1 port)	Digital Snap-Fit Connector ¹¹

¹¹. Mating connector is Hirose ST40X-10S-CV(30).



USB

Solid-State Switch

USB-1SP2T-A44

Mini-Circuits

50Ω 0.1 to 43.5 GHz SP2T 2.92 mm female

CASE STYLE DRAWING (UE3202)

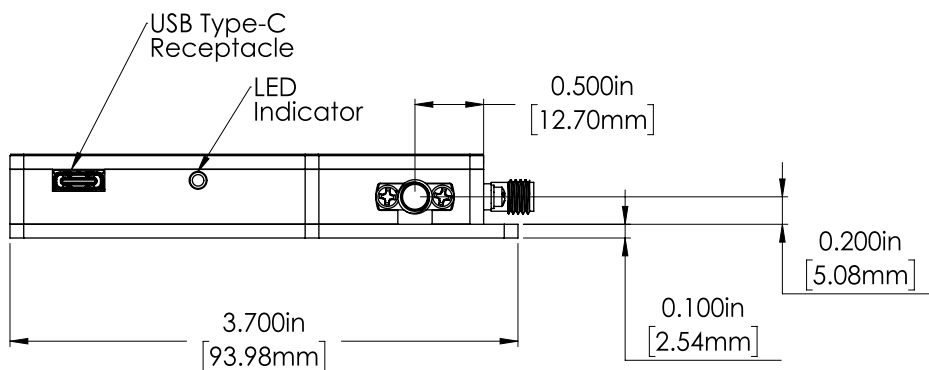
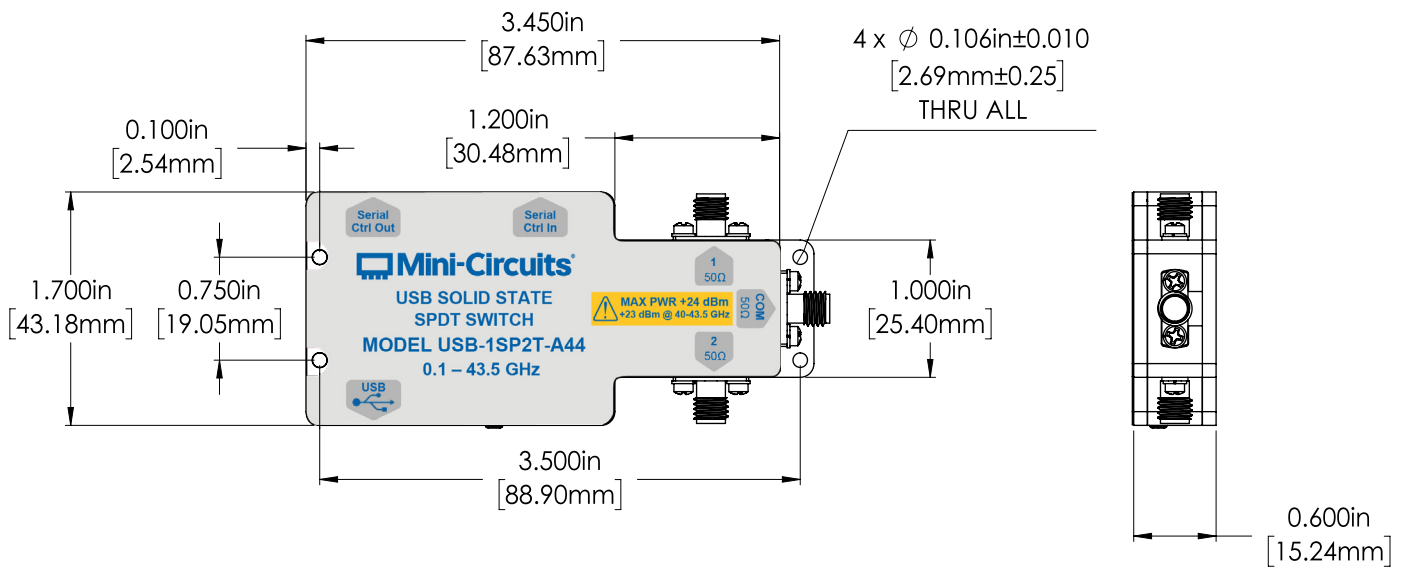
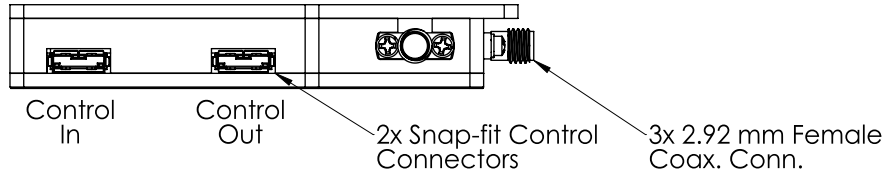

NOTES:

1. Case material: Aluminium alloy.
2. Case finish: Nickel plate.
3. Dimensions: Inches [mm].
4. Tolerances 2 Pl. ±.03 inch; 3 Pl. ±.015 inch
5. Weight: 550 grams.
6. Marking may contain other features or characters for internal lot control.

Mini-Circuits

**USB**

Solid-State Switch

USB-1SP2T-A44

Mini-Circuits

50Ω 0.1 to 43.5 GHz SP2T 2.92 mm female





DETAILED MODEL INFORMATION IS AVAILABLE ON OUR WEBSITE [CLICK HERE](#)

Performance Data & Graphs	Data Graphs
Case Style	UE3202
Environmental Rating	ENV55
Software, User Guide & Programming Manual	https://www.minicircuits.com/softwaredownload/solidstate.html
Regulatory Compliance	<p>Refer to user guide for compliance information</p>  https://www.minicircuits.com/app/AN49-012.pdf
Support	testsolutions@minicircuits.com

INCLUDED ACCESSORIES

	Part No.	Description	Qty.
	USB-CBL-AC-3+	3.3 ft (1.0 m) USB cable: USB type A (Male) to USB type C (Male)	1

OPTIONAL ACCESSORIES

	Part No.	Description
	USB-CBL-AC-3+ (spare)	3.3 ft (1.0 m) USB cable: USB type A (Male) to USB type C (Male)
	USB-CBL-CC-3+	3.3 ft (1.0 m) USB cable: USB type C (Male) to USB type C (Male)
	CBL-1.5FT-MMD+	1.5 ft (0.5 m) Cable assembly for serial control daisy chain with snap-fit connectors
	CBL-5FT-MMD+	5.0 ft (1.5 m) Cable assembly for serial control daisy chain with snap-fit connectors
	USB-AC/DC-5	AC/DC +5V power adaptor with USB connector ^{12, 13}

12. The power adaptor may be used to provide additional power via USB port when connecting several units in daisy chain control.

13. Includes power plugs for US, UK, EU, IL, AU & China. Plugs for other countries are also available. If you need a power cord for a country not listed please contact testsolutions@minicircuits.com

NOTES:

- A. Performance and quality attributes and conditions not expressly stated in this specification document are intended to be excluded and do not form a part of this specification document.
- B. Electrical specifications and performance data contained in this specification document are based on Mini-Circuit's applicable established test performance criteria and measurement instructions.
- C. The parts covered by this specification document are subject to Mini-Circuits standard limited warranty and terms and conditions (collectively, "Standard Terms"); Purchasers of this part are entitled to the rights and benefits contained therein. For a full statement of the Standard Terms and the exclusive rights and remedies thereunder, please visit Mini-Circuits' website at <https://www.minicircuits.com/terms/viewterm.html>



SP2T Solid-State Switch

Typical Performance Data

Test Conditions: @ Temperature = -10°C, Pin = 5 dBm.

Freq. (GHz)	Insertion Loss (dB)		Isolation, Active states (dB)			Isolation, Disconnected states (dB)		
	COM-1	COM-2	COM-1	COM-2	1-2	COM-1	COM-2	1-2
0.10	-0.69	-0.69	-86.97	-91.81	-94.22	-87.44	-88.93	-90.76
0.50	-0.74	-0.74	-87.15	-87.04	-95.26	-84.88	-85.19	-102.65
1.00	-0.79	-0.78	-80.88	-81.38	-89.25	-78.73	-78.34	-94.93
2.00	-0.84	-0.84	-74.93	-74.67	-82.58	-72.49	-72.42	-89.54
3.00	-0.90	-0.90	-71.45	-71.44	-78.39	-68.96	-68.82	-87.11
4.00	-0.93	-0.93	-69.22	-69.65	-75.50	-66.51	-66.63	-85.32
5.00	-0.97	-0.97	-67.62	-67.94	-74.64	-64.80	-65.27	-82.57
6.00	-1.02	-1.02	-66.45	-66.31	-73.80	-63.46	-63.87	-81.21
7.00	-1.05	-1.05	-65.34	-65.10	-72.78	-62.48	-62.51	-79.74
8.00	-1.08	-1.08	-64.46	-64.17	-72.00	-61.58	-61.47	-78.74
9.00	-1.11	-1.11	-63.55	-63.39	-70.95	-60.73	-60.70	-77.38
10.00	-1.14	-1.14	-62.75	-62.71	-70.06	-59.92	-59.96	-76.34
11.00	-1.22	-1.22	-61.75	-61.93	-69.04	-58.92	-59.13	-74.15
12.00	-1.30	-1.30	-61.21	-61.66	-69.28	-58.42	-58.66	-72.94
13.00	-1.42	-1.41	-60.73	-61.39	-71.03	-58.21	-58.51	-71.96
14.00	-1.51	-1.49	-59.94	-60.75	-73.82	-58.00	-58.40	-71.20
15.50	-1.55	-1.54	-58.55	-59.29	-74.26	-57.27	-57.55	-71.69
17.00	-1.58	-1.57	-57.99	-58.10	-73.86	-56.50	-56.48	-73.91
18.50	-1.65	-1.65	-58.19	-57.76	-71.99	-56.17	-55.80	-77.21
20.00	-1.71	-1.71	-58.59	-57.76	-66.99	-56.08	-55.36	-83.05
21.50	-1.80	-1.79	-59.47	-58.00	-66.00	-56.24	-55.23	-87.99
23.00	-1.91	-1.89	-60.66	-58.91	-66.27	-56.42	-55.25	-87.30
24.50	-1.99	-1.96	-61.05	-59.37	-64.51	-56.68	-55.43	-85.01
26.00	-2.03	-2.00	-62.09	-60.57	-64.31	-56.90	-55.74	-81.62
27.50	-2.08	-2.05	-63.02	-61.44	-64.39	-57.00	-55.79	-78.92
29.00	-2.18	-2.15	-63.54	-63.32	-64.45	-57.08	-56.23	-84.28
30.00	-2.20	-2.16	-63.46	-62.91	-64.03	-57.25	-56.42	-81.81
31.00	-2.29	-2.25	-63.88	-64.92	-64.52	-57.43	-56.76	-79.65
32.00	-2.28	-2.24	-64.54	-65.38	-65.68	-57.61	-57.12	-77.94
33.00	-2.34	-2.29	-64.53	-64.40	-65.22	-57.46	-56.91	-77.50
34.00	-2.36	-2.32	-64.14	-63.14	-64.55	-56.84	-56.54	-76.16
35.00	-2.51	-2.47	-63.24	-62.31	-63.52	-56.23	-56.03	-73.58
36.00	-2.75	-2.65	-61.36	-60.51	-62.57	-55.75	-55.53	-68.53
37.00	-2.79	-2.73	-59.61	-59.54	-61.86	-53.38	-53.25	-65.16
38.00	-3.00	-2.90	-57.58	-58.37	-58.59	-51.39	-51.30	-64.17
39.00	-2.97	-2.92	-57.00	-58.08	-57.71	-50.48	-50.39	-64.32
40.00	-3.24	-3.17	-57.05	-58.58	-56.92	-50.40	-50.41	-64.39
41.00	-3.37	-3.34	-58.09	-61.88	-56.39	-50.05	-50.21	-63.71
42.00	-3.69	-3.66	-53.95	-54.51	-58.71	-48.39	-48.20	-63.29
43.00	-3.47	-3.32	-54.21	-53.30	-52.89	-44.56	-44.20	-71.67
44.00	-3.74	-3.60	-57.36	-59.23	-50.14	-44.01	-43.68	-62.71

SP2T Solid-State Switch

Typical Performance Data

Test Conditions: @ Temperature = -10°C, Pin = 5 dBm.

Freq. (GHz)	Return Loss, Active ports (dB)			RL, Terminated ports (dB)	
	COM	1	2	1	2
0.10	-23.06	-22.96	-22.97	-30.06	-30.01
0.50	-22.36	-22.33	-22.37	-30.66	-30.50
1.00	-21.95	-21.81	-21.80	-29.75	-29.70
2.00	-21.41	-21.33	-21.29	-27.67	-27.44
3.00	-21.10	-21.52	-21.64	-25.82	-25.58
4.00	-21.42	-22.31	-22.41	-24.38	-24.17
5.00	-22.02	-23.46	-23.49	-23.64	-23.45
6.00	-22.99	-24.39	-24.49	-22.92	-22.78
7.00	-23.71	-25.68	-25.93	-22.31	-22.13
8.00	-24.30	-26.17	-26.66	-21.68	-21.46
9.00	-24.30	-24.94	-25.41	-21.48	-21.22
10.00	-22.36	-22.82	-23.07	-21.40	-21.19
11.00	-19.28	-19.29	-19.47	-21.74	-21.72
12.00	-17.66	-17.28	-17.55	-22.54	-22.51
13.00	-16.28	-15.59	-15.91	-22.88	-22.79
14.00	-16.54	-15.07	-15.32	-23.70	-23.32
15.50	-19.45	-16.01	-15.96	-26.33	-24.97
17.00	-20.48	-18.40	-17.70	-29.89	-26.67
18.50	-23.05	-20.15	-18.82	-38.22	-30.28
20.00	-20.91	-19.82	-18.02	-35.38	-33.27
21.50	-18.82	-17.95	-17.18	-32.91	-33.65
23.00	-18.58	-17.64	-17.71	-32.57	-35.59
24.50	-21.02	-19.81	-20.34	-35.29	-36.59
26.00	-25.16	-21.97	-22.46	-38.10	-36.30
27.50	-24.21	-20.76	-20.45	-32.65	-32.48
29.00	-21.91	-17.29	-16.81	-30.65	-29.84
30.00	-22.66	-16.70	-16.51	-28.74	-28.24
31.00	-29.54	-16.84	-16.66	-25.35	-24.90
32.00	-28.51	-18.85	-18.69	-23.38	-23.02
33.00	-26.20	-21.41	-21.84	-23.44	-23.64
34.00	-35.61	-20.78	-21.93	-18.80	-20.11
35.00	-16.82	-20.63	-20.52	-17.21	-19.94
36.00	-14.13	-15.26	-18.17	-16.39	-20.61
37.00	-31.40	-16.36	-17.81	-22.54	-31.43
38.00	-16.32	-12.58	-14.59	-19.52	-21.72
39.00	-20.99	-30.77	-38.16	-16.48	-17.76
40.00	-15.13	-17.66	-19.83	-15.56	-17.22
41.00	-17.04	-15.74	-15.77	-11.55	-12.26
42.00	-17.19	-15.53	-19.18	-14.37	-14.25
43.00	-11.23	-10.59	-12.27	-16.42	-19.22
44.00	-13.99	-13.15	-14.71	-22.33	-27.54

SP2T Solid-State Switch

Typical Performance Data

Test Conditions: @ Temperature = +25°C, Pin = 5 dBm.

Freq. (GHz)	Insertion Loss (dB)		Isolation, Active states (dB)			Isolation, Disconnected states (dB)		
	COM-1	COM-2	COM-1	COM-2	1-2	COM-1	COM-2	1-2
0.10	-0.75	-0.75	-90.72	-89.80	-91.62	-91.37	-87.69	-89.96
0.50	-0.81	-0.81	-87.13	-86.20	-94.56	-84.64	-84.54	-98.72
1.00	-0.85	-0.86	-80.62	-80.51	-88.49	-77.97	-78.00	-98.37
2.00	-0.92	-0.92	-74.68	-74.42	-81.98	-72.10	-71.97	-90.72
3.00	-0.98	-0.98	-71.11	-71.11	-77.57	-68.43	-68.33	-87.30
4.00	-1.02	-1.03	-68.94	-69.30	-75.08	-66.00	-66.24	-84.64
5.00	-1.07	-1.07	-67.26	-67.34	-73.95	-64.29	-64.64	-82.84
6.00	-1.11	-1.12	-65.93	-65.87	-73.00	-62.96	-63.11	-80.85
7.00	-1.14	-1.15	-64.95	-64.69	-71.77	-61.92	-61.90	-80.07
8.00	-1.18	-1.18	-63.91	-63.73	-70.78	-60.97	-60.83	-78.55
9.00	-1.21	-1.21	-63.03	-63.03	-69.83	-60.06	-60.10	-77.22
10.00	-1.25	-1.25	-62.18	-62.26	-68.92	-59.22	-59.32	-75.90
11.00	-1.33	-1.33	-61.25	-61.40	-67.95	-58.18	-58.42	-74.31
12.00	-1.43	-1.42	-60.69	-61.10	-68.10	-57.63	-57.90	-72.96
13.00	-1.55	-1.54	-60.19	-60.83	-69.49	-57.35	-57.68	-71.65
14.00	-1.65	-1.64	-59.40	-60.21	-71.27	-57.14	-57.55	-71.17
15.50	-1.70	-1.69	-58.06	-58.76	-70.93	-56.51	-56.85	-71.70
17.00	-1.73	-1.72	-57.53	-57.68	-70.51	-55.69	-55.76	-73.55
18.50	-1.81	-1.81	-57.72	-57.35	-70.10	-55.38	-55.13	-76.86
20.00	-1.88	-1.89	-58.00	-57.28	-66.24	-55.37	-54.83	-82.52
21.50	-1.99	-1.98	-58.87	-57.63	-65.36	-55.59	-54.75	-87.13
23.00	-2.09	-2.07	-60.02	-58.48	-65.85	-55.83	-54.84	-87.13
24.50	-2.18	-2.15	-60.42	-58.91	-63.99	-56.00	-54.89	-87.06
26.00	-2.24	-2.20	-61.49	-60.10	-63.86	-56.32	-55.21	-82.91
27.50	-2.31	-2.27	-62.67	-60.94	-63.90	-56.51	-55.25	-80.08
29.00	-2.41	-2.37	-63.35	-62.70	-63.93	-56.63	-55.67	-85.39
30.00	-2.43	-2.39	-63.40	-62.36	-63.38	-56.72	-55.70	-83.07
31.00	-2.53	-2.48	-63.89	-64.25	-63.78	-56.89	-56.11	-80.91
32.00	-2.54	-2.49	-64.61	-64.85	-64.85	-57.07	-56.38	-79.25
33.00	-2.60	-2.54	-64.68	-63.97	-64.33	-56.88	-56.07	-78.23
34.00	-2.61	-2.56	-64.41	-62.78	-63.74	-56.50	-55.86	-75.97
35.00	-2.77	-2.72	-63.48	-61.79	-62.61	-55.80	-55.19	-72.33
36.00	-2.98	-2.88	-61.21	-59.86	-61.50	-55.10	-54.55	-67.75
37.00	-3.10	-3.01	-59.22	-59.06	-60.51	-52.82	-52.52	-64.83
38.00	-3.26	-3.15	-57.13	-57.81	-57.51	-50.90	-50.68	-64.46
39.00	-3.28	-3.19	-56.71	-57.67	-56.65	-50.24	-50.13	-64.93
40.00	-3.63	-3.51	-56.93	-58.25	-56.21	-50.18	-50.39	-65.22
41.00	-3.68	-3.60	-57.30	-61.04	-55.87	-49.56	-49.95	-64.99
42.00	-4.05	-3.99	-53.52	-53.93	-57.87	-48.30	-48.34	-64.26
43.00	-3.87	-3.69	-54.83	-53.49	-53.37	-44.23	-44.00	-72.95
44.00	-4.09	-3.97	-59.94	-56.70	-50.85	-44.47	-43.70	-61.65

SP2T Solid-State Switch

Typical Performance Data

Test Conditions: @ Temperature = +25°C, Pin = 5 dBm.

Freq. (GHz)	Return Loss, Active ports (dB)			RL, Terminated ports (dB)	
	COM	1	2	1	2
0.10	-22.34	-22.28	-22.34	-30.52	-30.35
0.50	-21.82	-21.78	-21.81	-30.70	-30.60
1.00	-21.37	-21.31	-21.38	-30.18	-29.90
2.00	-20.88	-20.97	-21.02	-28.04	-27.77
3.00	-20.73	-21.23	-21.30	-26.17	-25.89
4.00	-20.97	-21.75	-21.81	-24.81	-24.57
5.00	-21.59	-22.69	-22.82	-23.67	-23.42
6.00	-22.35	-24.07	-24.37	-22.80	-22.53
7.00	-23.17	-25.09	-25.28	-22.31	-22.16
8.00	-23.73	-25.19	-25.52	-21.94	-21.70
9.00	-23.29	-24.22	-24.43	-21.66	-21.53
10.00	-21.81	-22.25	-22.46	-21.63	-21.53
11.00	-19.08	-19.07	-19.30	-21.95	-21.93
12.00	-16.98	-16.81	-17.15	-22.39	-22.44
13.00	-16.09	-15.55	-15.89	-23.31	-23.26
14.00	-16.41	-15.11	-15.47	-24.34	-24.03
15.50	-19.26	-16.24	-16.19	-26.96	-25.62
17.00	-21.90	-18.83	-18.16	-32.08	-28.24
18.50	-22.88	-20.33	-18.92	-45.28	-31.38
20.00	-20.44	-19.51	-17.93	-37.01	-33.05
21.50	-18.47	-17.82	-17.02	-33.00	-32.45
23.00	-19.07	-17.97	-17.84	-33.67	-32.91
24.50	-21.76	-20.13	-20.44	-37.37	-34.54
26.00	-24.27	-22.06	-22.46	-38.03	-35.44
27.50	-23.55	-20.88	-20.73	-34.70	-34.10
29.00	-22.64	-17.85	-17.58	-32.20	-31.76
30.00	-23.51	-16.96	-16.77	-29.78	-29.05
31.00	-26.00	-17.06	-16.94	-26.36	-26.02
32.00	-27.19	-17.79	-17.86	-23.47	-23.56
33.00	-26.99	-18.61	-18.96	-21.06	-21.52
34.00	-34.03	-22.70	-23.80	-18.48	-19.74
35.00	-16.70	-21.75	-22.02	-16.95	-19.62
36.00	-15.45	-16.44	-19.04	-17.86	-22.74
37.00	-28.54	-15.60	-17.32	-21.45	-29.55
38.00	-18.23	-13.82	-15.82	-21.11	-21.67
39.00	-22.83	-31.49	-38.52	-16.64	-17.65
40.00	-14.53	-16.64	-18.77	-14.93	-16.55
41.00	-20.38	-20.02	-19.86	-14.07	-14.67
42.00	-18.62	-15.97	-19.15	-14.60	-14.27
43.00	-12.96	-13.03	-14.68	-19.65	-22.43
44.00	-15.72	-14.35	-16.09	-24.68	-31.29

SP2T Solid-State Switch

Typical Performance Data

Test Conditions: @ Temperature = +60°C, Pin = 5 dBm.

Freq. (GHz)	Insertion Loss (dB)		Isolation, Active states (dB)			Isolation, Disconnected states (dB)		
	COM-1	COM-2	COM-1	COM-2	1-2	COM-1	COM-2	1-2
0.10	-0.82	-0.81	-91.14	-89.03	-96.03	-89.04	-87.94	-96.99
0.50	-0.88	-0.86	-86.36	-86.03	-94.03	-84.37	-84.07	-99.29
1.00	-0.93	-0.91	-80.38	-79.76	-88.15	-77.52	-77.35	-96.89
2.00	-1.00	-0.98	-74.11	-74.02	-81.06	-71.33	-71.34	-91.01
3.00	-1.06	-1.05	-70.64	-70.73	-76.84	-67.78	-67.67	-87.54
4.00	-1.10	-1.09	-68.34	-68.73	-74.19	-65.28	-65.59	-85.69
5.00	-1.15	-1.13	-66.72	-66.92	-72.97	-63.48	-64.00	-82.29
6.00	-1.20	-1.18	-65.39	-65.28	-72.00	-62.18	-62.47	-80.85
7.00	-1.23	-1.22	-64.30	-64.11	-70.75	-61.12	-61.17	-79.39
8.00	-1.26	-1.25	-63.26	-63.21	-69.66	-60.15	-60.20	-78.50
9.00	-1.30	-1.28	-62.35	-62.47	-68.69	-59.23	-59.37	-77.21
10.00	-1.34	-1.32	-61.54	-61.65	-67.86	-58.35	-58.59	-75.86
11.00	-1.42	-1.40	-60.51	-60.79	-66.87	-57.29	-57.58	-74.33
12.00	-1.54	-1.51	-60.00	-60.41	-66.76	-56.70	-57.03	-72.76
13.00	-1.67	-1.63	-59.46	-60.16	-67.73	-56.35	-56.76	-71.51
14.00	-1.77	-1.73	-58.66	-59.52	-68.97	-56.09	-56.60	-70.80
15.50	-1.83	-1.79	-57.32	-58.11	-68.26	-55.43	-55.89	-71.44
17.00	-1.87	-1.83	-56.79	-57.07	-67.89	-54.63	-54.87	-73.12
18.50	-1.96	-1.93	-56.92	-56.75	-67.79	-54.35	-54.34	-76.21
20.00	-2.03	-2.01	-57.13	-56.62	-64.73	-54.35	-54.07	-80.85
21.50	-2.14	-2.11	-57.88	-56.97	-63.98	-54.60	-54.03	-84.27
23.00	-2.27	-2.22	-58.99	-57.83	-64.60	-54.85	-54.12	-87.25
24.50	-2.36	-2.30	-59.37	-58.25	-63.03	-55.02	-54.20	-86.94
26.00	-2.42	-2.35	-60.42	-59.37	-62.75	-55.27	-54.41	-84.27
27.50	-2.49	-2.42	-61.69	-60.18	-62.80	-55.45	-54.45	-80.39
29.00	-2.60	-2.53	-62.36	-61.81	-62.64	-55.62	-54.81	-88.11
30.00	-2.62	-2.55	-62.66	-61.67	-62.24	-55.76	-54.94	-85.08
31.00	-2.72	-2.65	-63.10	-63.26	-62.55	-55.90	-55.25	-83.58
32.00	-2.73	-2.65	-63.87	-64.26	-63.40	-56.03	-55.53	-81.13
33.00	-2.80	-2.71	-64.08	-63.46	-63.20	-55.95	-55.30	-78.99
34.00	-2.83	-2.74	-64.03	-62.74	-62.59	-55.40	-54.90	-76.09
35.00	-3.00	-2.92	-63.22	-61.68	-61.48	-54.84	-54.37	-72.11
36.00	-3.23	-3.09	-60.73	-59.53	-60.56	-54.21	-53.74	-67.15
37.00	-3.35	-3.22	-58.71	-58.40	-59.56	-52.00	-51.70	-64.45
38.00	-3.53	-3.38	-56.53	-56.98	-56.54	-50.12	-50.05	-64.62
39.00	-3.54	-3.42	-56.37	-57.09	-55.72	-49.64	-49.68	-65.42
40.00	-3.85	-3.71	-56.41	-57.46	-55.28	-49.64	-49.92	-66.14
41.00	-3.97	-3.86	-56.89	-59.86	-54.93	-49.14	-49.62	-65.24
42.00	-4.35	-4.25	-53.06	-53.41	-56.52	-47.73	-47.79	-64.36
43.00	-4.08	-3.90	-54.43	-52.72	-53.21	-44.21	-44.00	-75.15
44.00	-4.35	-4.18	-57.93	-56.22	-50.48	-44.23	-43.39	-62.23

NOTES:

- A. Performance and quality attributes and conditions not expressly stated in this specification document are intended to be excluded and do not form a part of this specification document.
- B. Electrical specifications and performance data contained in this specification document are based on Mini-Circuits' applicable established test performance criteria and measurement instructions.
- C. The parts covered by this specification document are subject to Mini-Circuits standard limited warranty and terms and conditions (collectively, "Standard Terms"); Purchasers of this part are entitled to the rights and benefits contained therein. For a full statement of the Standard Terms and the exclusive rights and remedies thereunder, please visit Mini-Circuits' website at <https://www.minicircuits.com/terms/viewterm.html>



SP2T Solid-State Switch

Typical Performance Data

Test Conditions: @ Temperature = +60°C, Pin = 5 dBm.

Freq. (GHz)	Return Loss, Active ports (dB)			RL, Terminated ports (dB)	
	COM	1	2	1	2
0.10	-21.56	-21.47	-21.62	-31.30	-31.08
0.50	-21.16	-21.12	-21.29	-31.06	-30.74
1.00	-20.77	-20.71	-20.84	-30.79	-30.47
2.00	-20.29	-20.38	-20.48	-28.66	-28.32
3.00	-20.12	-20.46	-20.58	-26.44	-26.06
4.00	-20.40	-21.11	-21.33	-24.69	-24.33
5.00	-21.00	-22.23	-22.53	-23.73	-23.42
6.00	-21.80	-23.32	-23.59	-23.04	-22.80
7.00	-22.59	-24.24	-24.63	-22.48	-22.19
8.00	-22.76	-24.33	-24.73	-22.13	-21.88
9.00	-22.42	-23.51	-23.85	-21.97	-21.76
10.00	-21.46	-21.96	-22.20	-21.99	-21.84
11.00	-18.63	-18.68	-18.95	-21.86	-21.77
12.00	-16.88	-16.64	-16.98	-22.92	-22.94
13.00	-16.12	-15.49	-15.87	-23.68	-23.56
14.00	-16.68	-15.21	-15.53	-24.82	-24.43
15.50	-19.44	-16.27	-16.29	-27.44	-26.20
17.00	-21.21	-18.58	-18.00	-32.81	-28.68
18.50	-21.95	-19.87	-18.66	-44.95	-31.64
20.00	-19.69	-19.23	-17.86	-36.04	-32.93
21.50	-18.02	-17.54	-16.72	-32.78	-31.42
23.00	-18.71	-17.68	-17.57	-32.45	-32.06
24.50	-22.22	-19.53	-19.81	-32.82	-31.76
26.00	-25.24	-21.56	-22.03	-33.51	-32.34
27.50	-23.49	-20.47	-20.39	-35.16	-34.64
29.00	-22.01	-17.90	-17.57	-35.29	-34.68
30.00	-22.38	-16.85	-16.60	-30.32	-29.46
31.00	-25.61	-16.83	-16.90	-25.63	-25.30
32.00	-26.72	-17.91	-18.18	-22.86	-22.92
33.00	-26.38	-19.86	-20.35	-21.80	-22.49
34.00	-35.33	-21.20	-21.95	-18.73	-20.26
35.00	-16.52	-21.34	-21.30	-17.08	-19.82
36.00	-15.14	-16.39	-19.18	-17.72	-22.23
37.00	-27.02	-15.36	-16.94	-22.25	-29.49
38.00	-18.03	-13.48	-15.22	-19.66	-20.77
39.00	-21.06	-28.61	-36.16	-16.32	-17.46
40.00	-15.43	-17.86	-20.05	-15.44	-17.07
41.00	-19.71	-18.75	-18.11	-13.19	-13.38
42.00	-18.00	-15.45	-18.85	-15.38	-15.28
43.00	-12.90	-12.66	-14.07	-19.55	-22.42
44.00	-15.82	-14.70	-16.20	-24.76	-28.05

NOTES:

- A. Performance and quality attributes and conditions not expressly stated in this specification document are intended to be excluded and do not form a part of this specification document.
- B. Electrical specifications and performance data contained in this specification document are based on Mini-Circuits' applicable established test performance criteria and measurement instructions.
- C. The parts covered by this specification document are subject to Mini-Circuits standard limited warranty and terms and conditions (collectively, "Standard Terms"); Purchasers of this part are entitled to the rights and benefits contained therein. For a full statement of the Standard Terms and the exclusive rights and remedies thereunder, please visit Mini-Circuits' website at <https://www.minicircuits.com/terms/viewterm.html>



Typical Performance Graphs

Test Conditions: @ Temperature = -10°C, Pin = 5 dBm.

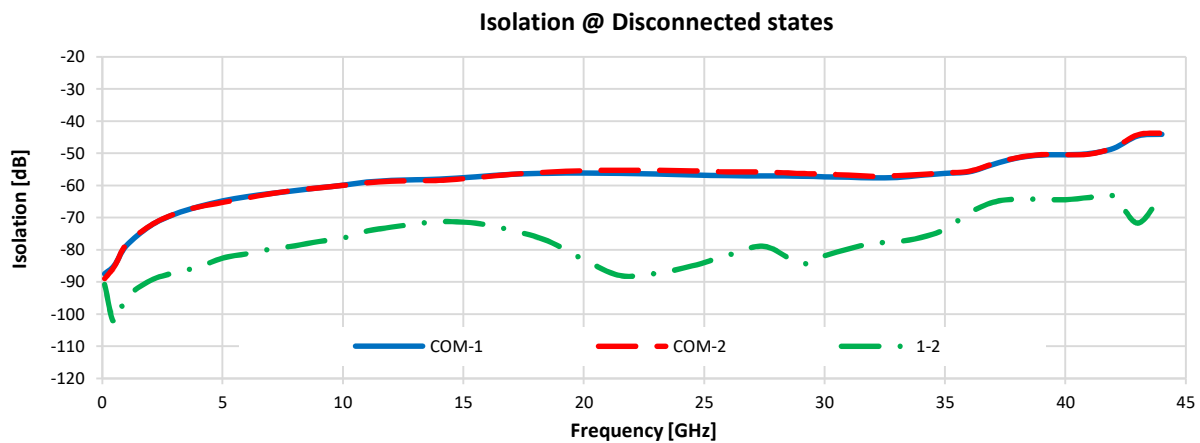
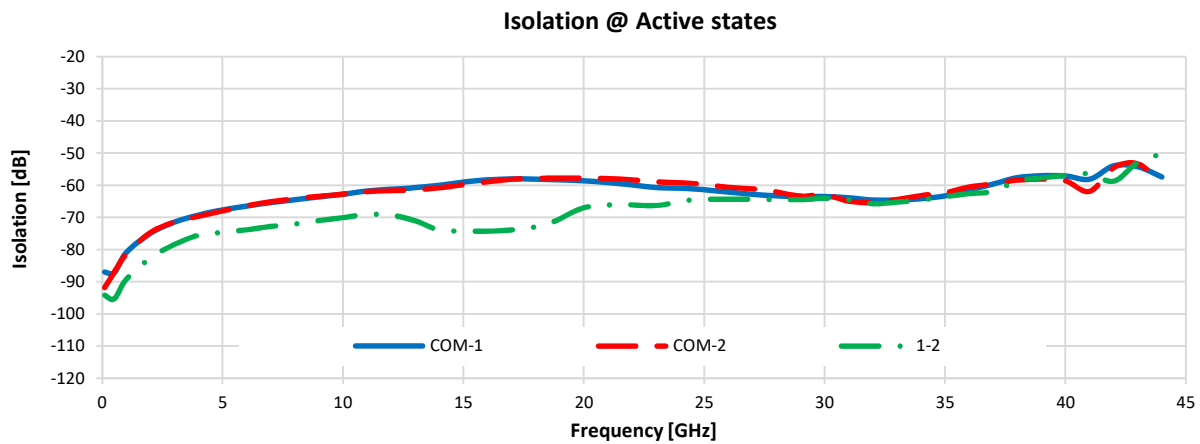
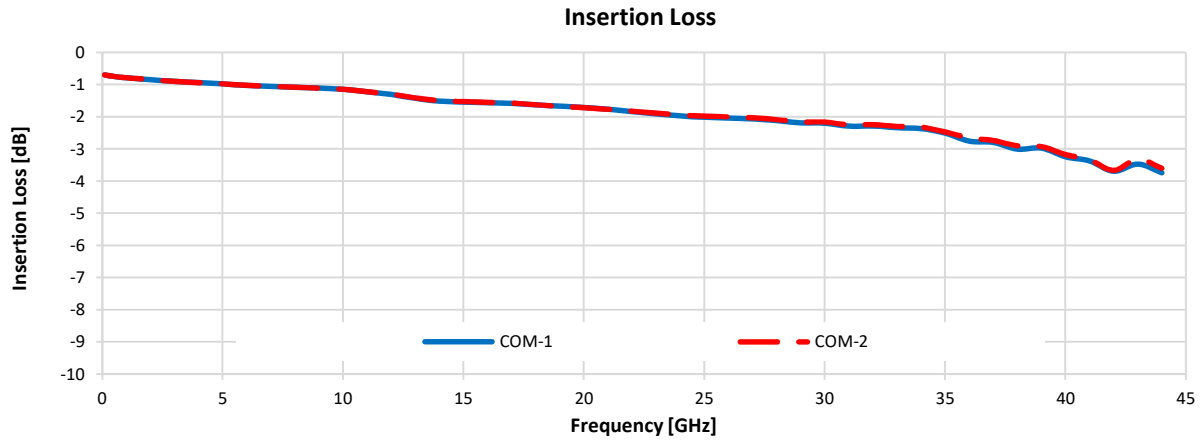

Typical Performance Graphs

Test Conditions: @ Temperature = -10°C, Pin = 5 dBm.

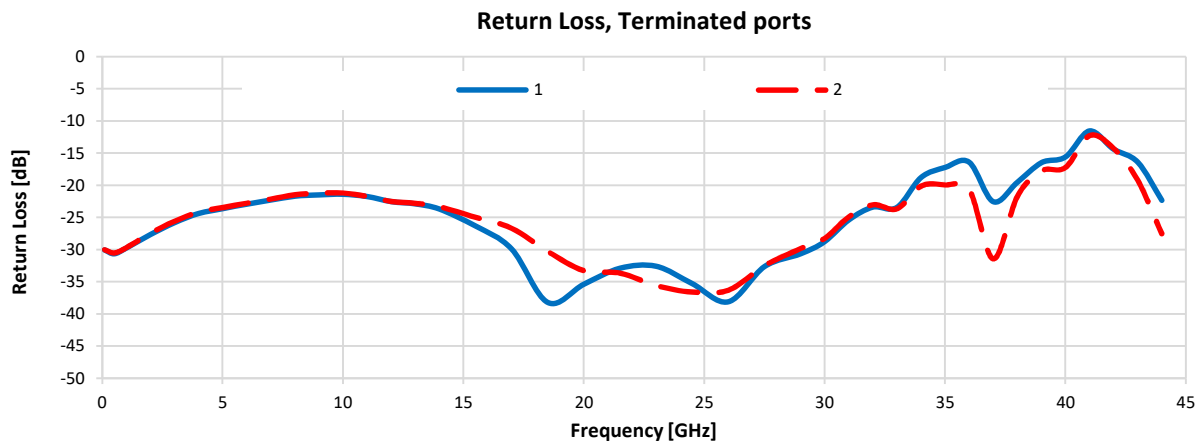
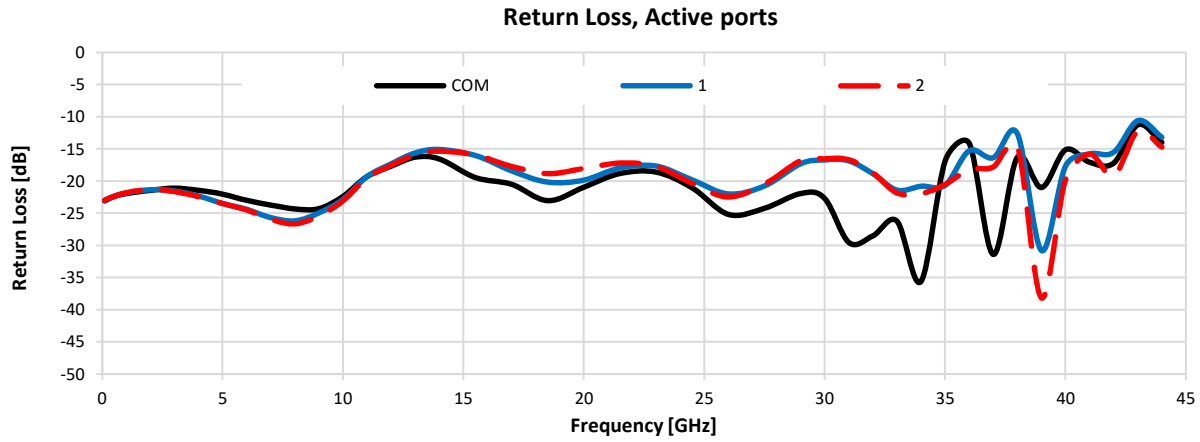

Typical Performance Graphs

Test Conditions: @ Temperature = +25°C, Pin = 5 dBm.

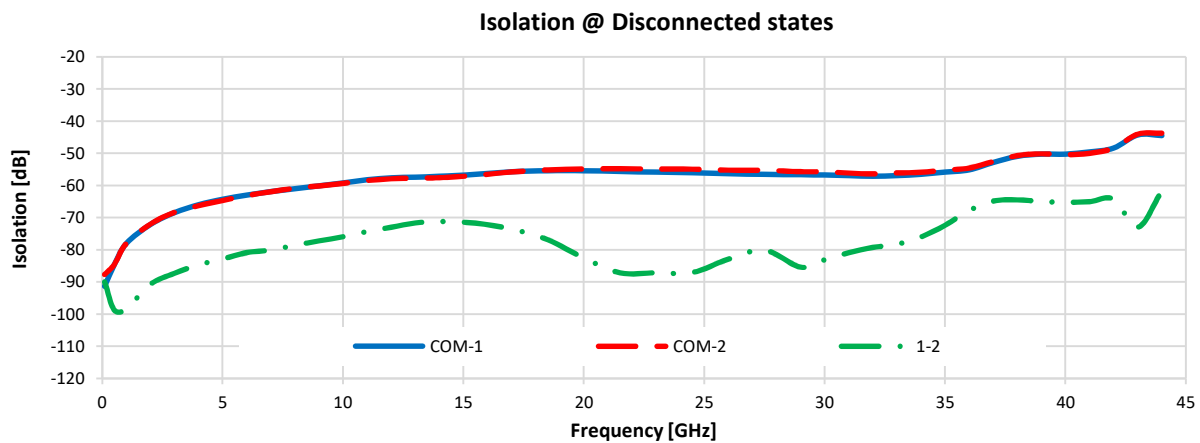
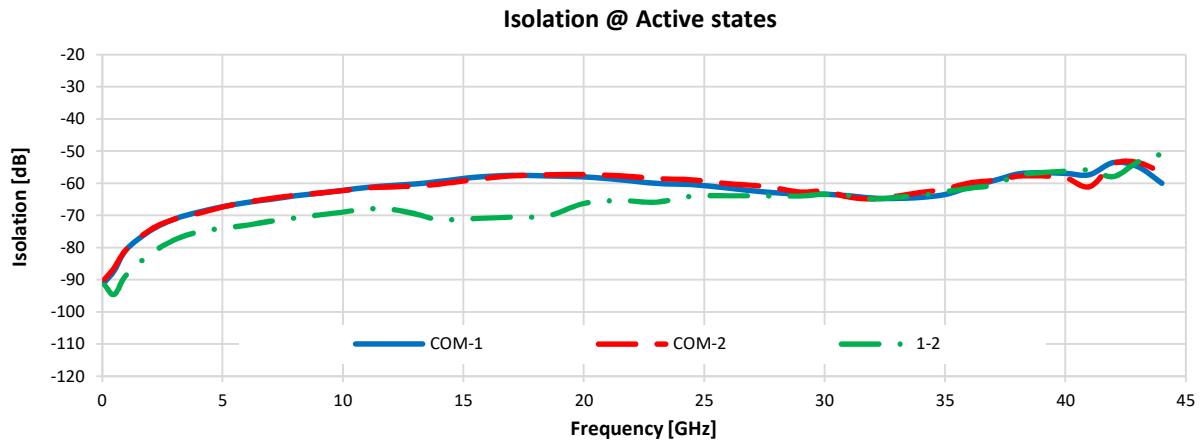
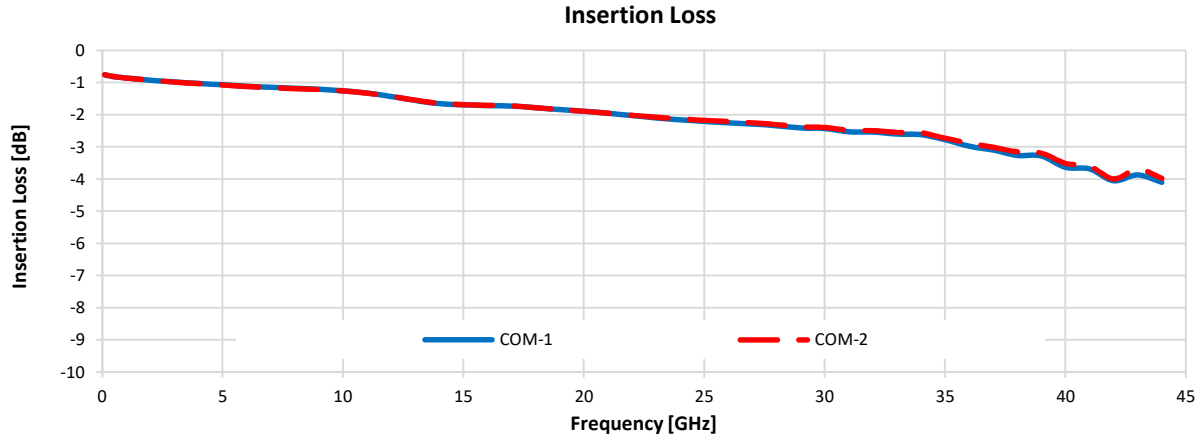

Typical Performance Graphs

Test Conditions: @ Temperature = +25°C, Pin = 5 dBm.

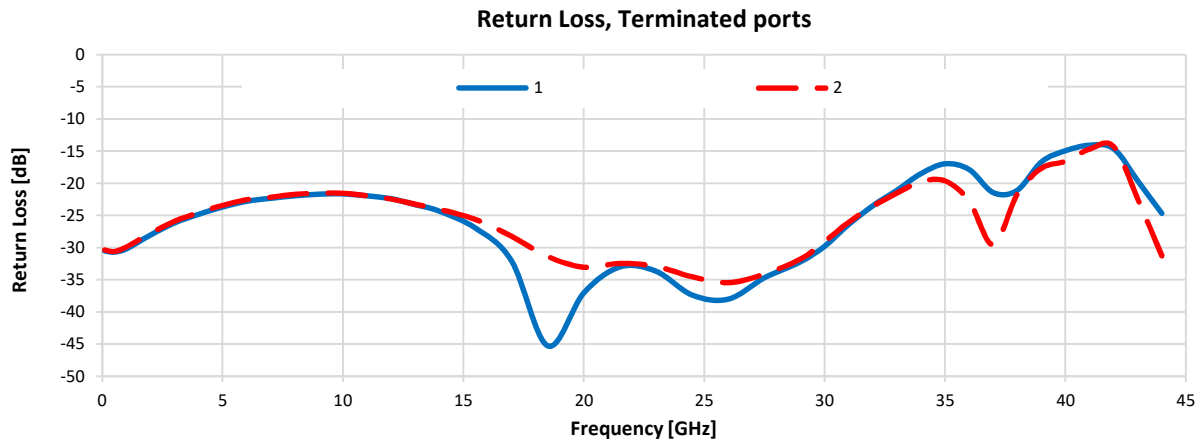
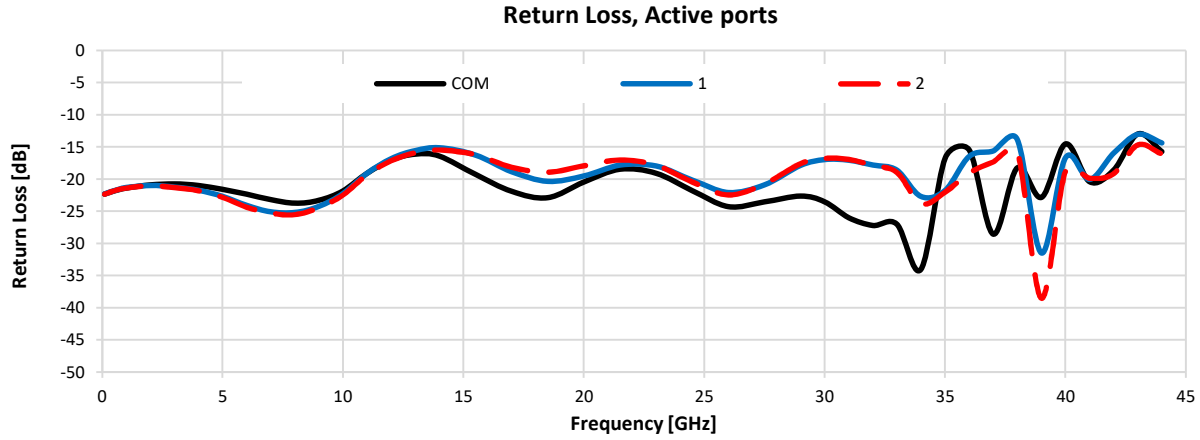

Typical Performance Graphs

Test Conditions: @ Temperature = +60°C, Pin = 5 dBm.

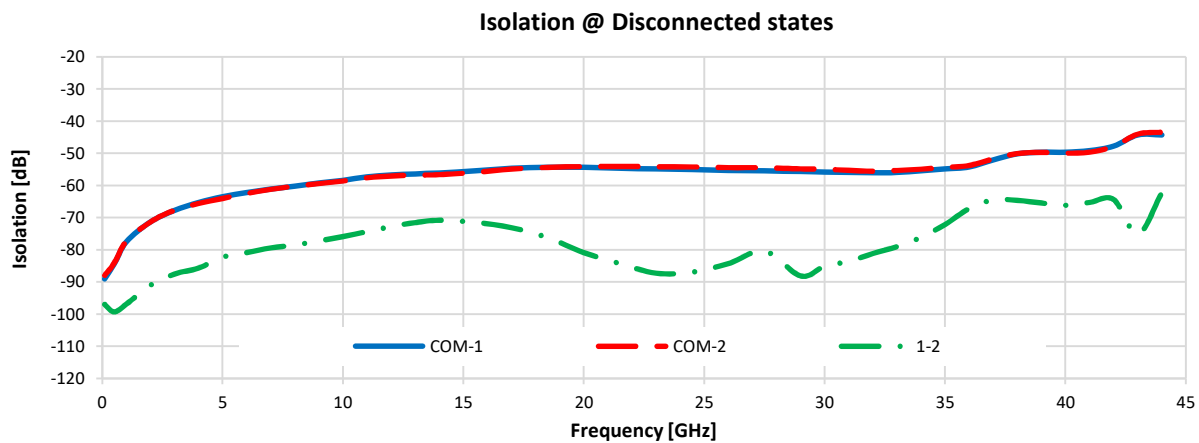
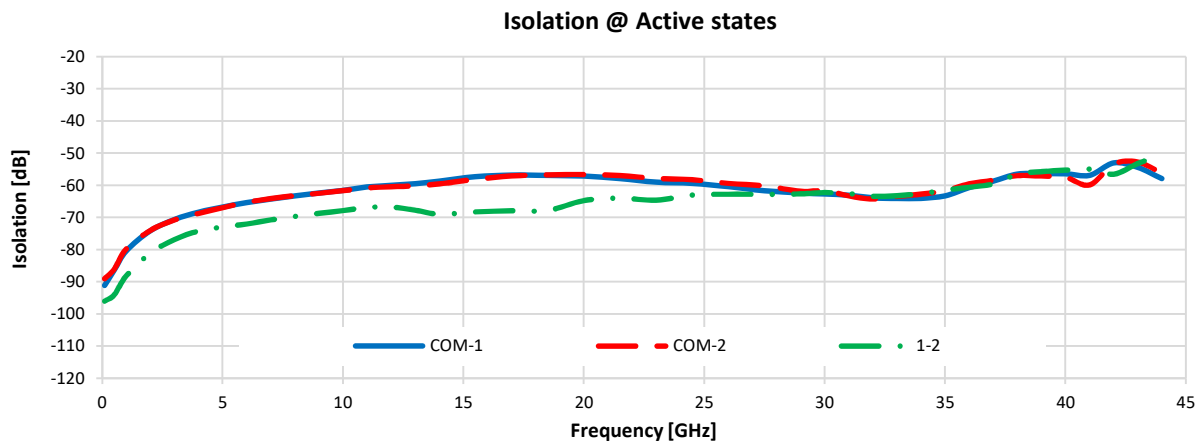
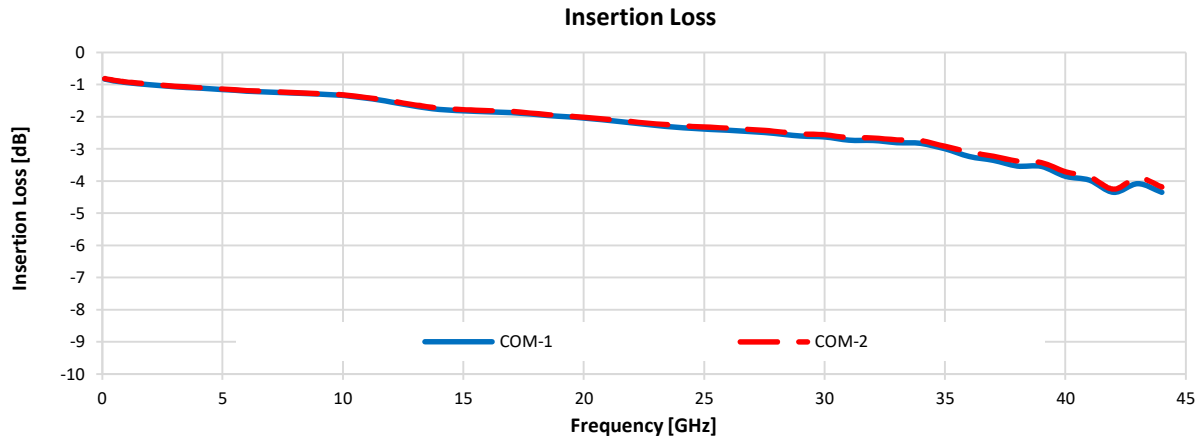

NOTES:

- A. Performance and quality attributes and conditions not expressly stated in this specification document are intended to be excluded and do not form a part of this specification document.
- B. Electrical specifications and performance data contained in this specification document are based on Mini-Circuit's applicable established test performance criteria and measurement instructions.
- C. The parts covered by this specification document are subject to Mini-Circuits standard limited warranty and terms and conditions (collectively, "Standard Terms"); Purchasers of this part are entitled to the rights and benefits contained therein. For a full statement of the Standard Terms and the exclusive rights and remedies thereunder, please visit Mini-Circuits' website at <https://www.minicircuits.com/terms/viewterm.html>



Typical Performance Graphs

Test Conditions: @ Temperature = +60°C, Pin = 5 dBm.

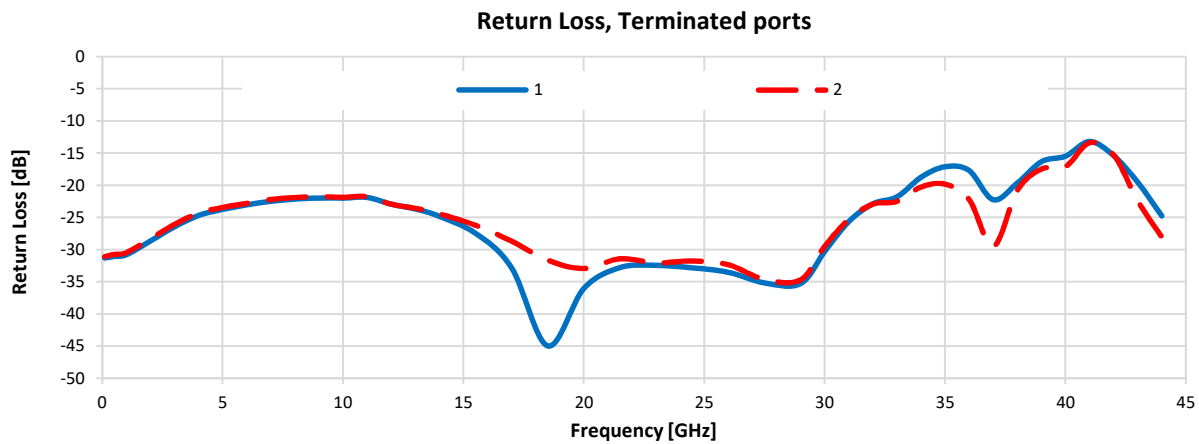
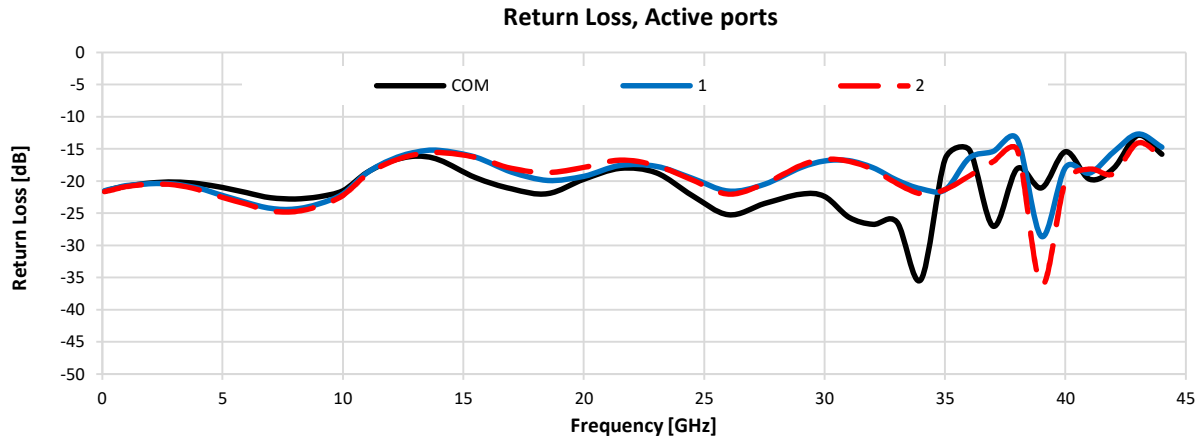

NOTES:

- A. Performance and quality attributes and conditions not expressly stated in this specification document are intended to be excluded and do not form a part of this specification document.
- B. Electrical specifications and performance data contained in this specification document are based on Mini-Circuit's applicable established test performance criteria and measurement instructions.
- C. The parts covered by this specification document are subject to Mini-Circuits standard limited warranty and terms and conditions (collectively, "Standard Terms"); Purchasers of this part are entitled to the rights and benefits contained therein. For a full statement of the Standard Terms and the exclusive rights and remedies thereunder, please visit Mini-Circuits' website at <https://www.minicircuits.com/terms/viewterm.html>



Case Style

UE

Outline Dimensions

UE3202

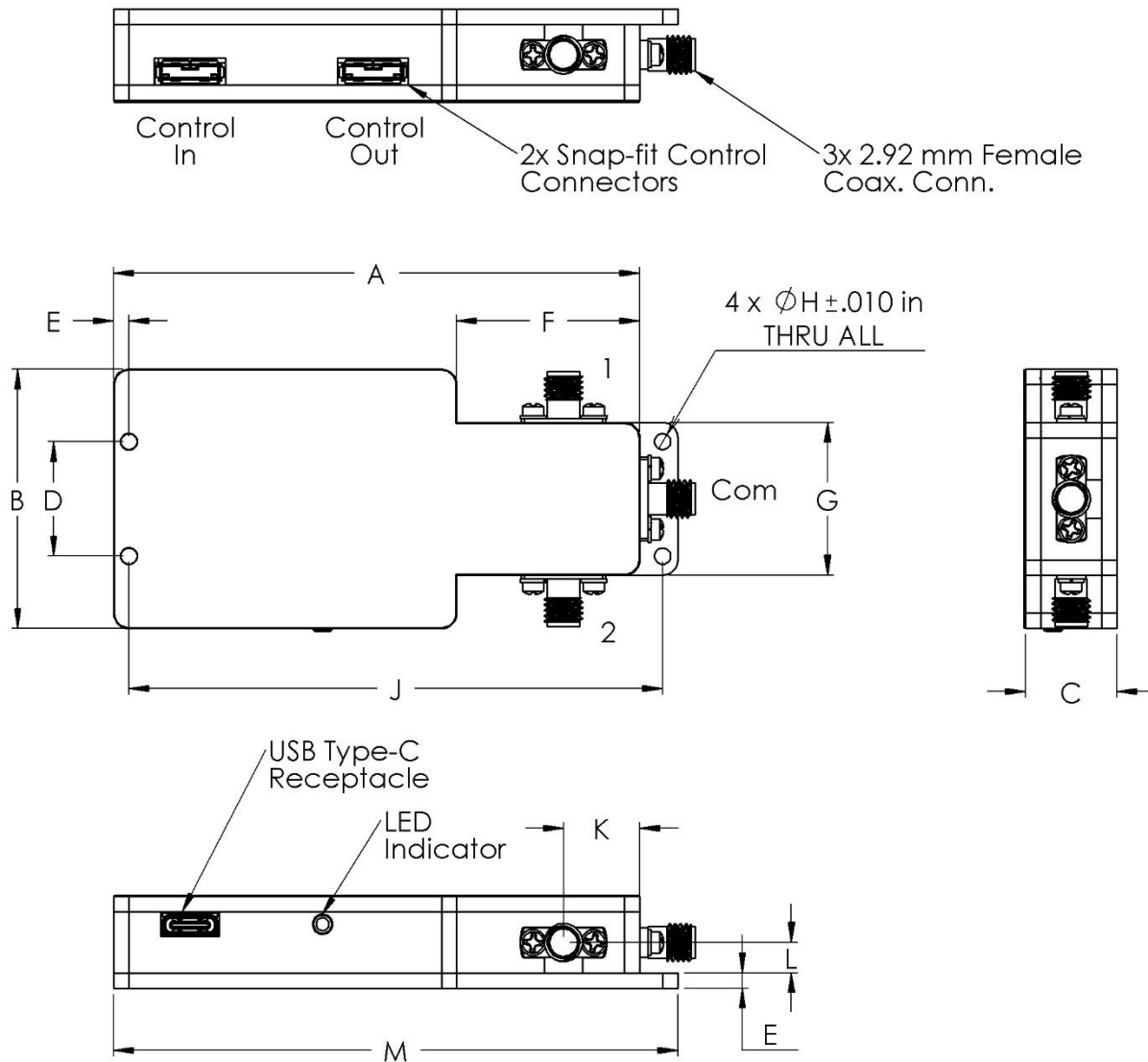

CASE#	A	B	C	D	E	F	G	H	J	K	L	M	WT. GRAMS
UE3202	3.45 (87.63)	1.70 (43.18)	.60 (15.24)	.750 (19.05)	.10 (2.54)	1.20 (30.48)	1.00 (25.40)	.106 (2.69)	3.500 (88.90)	0.50 (12.70)	.200 (5.08)	3.70 (93.98)	100

Dimensions are in inches (mm). Tolerances: 2PL. +/- .03; 3PL. +/- .015

Notes:

1. Case material: Nickel Plated Aluminum.

Mini-Circuits[®]

INTERNET <http://www.minicircuits.com>

P.O. Box 350166, Brooklyn, New York 11235-0003 (718) 934-4500 Fax (718) 332-4661

Distribution Centers NORTH AMERICA 800-654-7949 • 417-335-5935 • Fax 417-335-5945 • EUROPE 44-1252-832600 • Fax 44-1252-837010

Mini-Circuits ISO 9001 & ISO 14001 Certified



Environmental Specifications **ENV55**

All Mini-Circuits products are manufactured under exacting quality assurance and control standards, and are capable of meeting published specifications after being subjected to any or all of the following physical and environmental test.

Specification	Test/Inspection Condition	Reference/Spec
Operating Temperature	-0° to 50° C Ambient Environment	Individual Model Data Sheet
Storage Temperature	-20° to 60° C Ambient Environment	Individual Model Data Sheet
Operating and Storage Humidity	5% to 85% RH (non-condensing)	Ambient
Bench Handling Test	Bench Top Tip 45° & Drop	MIL-PRF-28800F
Transit Drop Test	Free Fall Drop, 20 cm (7.9 inches)	MIL-PRF-28800F Class 3