



USB | I²C

SP4T Switch

SOLID STATE

U2C-1SP4T-852H

50Ω

2 to 8500 MHz

SMA female

THE BIG DEAL

- I²C for control from a simple 2-wire control bus
- USB for easy and powerful software automation
- High-speed switch transition, 200 ns
- Very high isolation (80 dB)
- Small case (3.75" x 2.50" x 0.6")

APPLICATIONS

- High volume production testing / ATE
- 5G FR1, WiFi 6E, Bluetooth testing
- Design verification testing
- RF signal routing / switch matrices



Generic photo used for illustration purposes only

PRODUCT OVERVIEW

Mini-Circuits' U2C-1SP4T-852H is a low cost, absorptive SP4T switch with USB and I²C control. The fast switching, solid state switch operates from 2 MHz to 8500 MHz with 200 ns typical switch transition speed. High linearity (+50 dBm typ IP3), and high isolation (80 dB typical) allow the model to be used for a wide variety of RF applications.

The U2C-1SP4T-852H is housed in a compact, rugged metal case (3.75" x 2.50" x 0.6") with 5 SMA (F) connectors (COM, and J1 to J4), a USB Mini-B and a 9-pin D-sub connector for USB and I²C control and power.

Full software support is provided, including our user-friendly GUI application for Windows and a full API with programming instructions for Windows and Linux environments (both 32-bit and 64-bit systems).

KEY FEATURES

Feature	Advantages
Dual control interface (I ² C & USB)	USB provides a quick and easy PC control method with full software support, while I ² C allows multiple switches to be controlled in parallel from a microcontroller / embedded system using minimal hardware (2 wire control).
RF SP4T absorptive switch	Wideband (2 to 8500 MHz) with low insertion loss (4 dB typ.), high isolation (80 dB typ.).
High Linearity (IP3 +50 dBm typ.)	Excellent intermodulation performance, meeting requirements for digital communications signals.
DC Blocking at RF ports	Built in blocking capacitors eliminate the need for external DC blocking circuitry at RF ports (up to 16V _{DC}).

Trademarks:

Windows is a registered trademark of Microsoft Corporation in the United States and other countries ; Linux is a registered trademark of Linus Torvalds ; Pentium is a registered trademark of Intel Corporation. Neither Mini-Circuits nor the Mini-Circuits products are affiliated with or endorsed by the owners of the referenced trademarks. Mini-Circuits and the Mini-Circuits logo are registered trademarks of Scientific Components Corporation.



USB | I²C

SP4T Switch

SOLID STATE

U2C-1SP4T-852H

Mini-Circuits

50Ω

2 to 8500 MHz

SMA female

ELECTRICAL SPECIFICATIONS AT -10 TO 60°C

Parameter	Ports	Condition (MHz)	Min.	Typ.	Max.	Unit
Frequency range	-	-	2		8500	MHz
Insertion loss	COM to any active port	2 - 700	-	2.3	3.5	dB
		700 - 2500	-	3.0	4.5	
		2500 - 5000	-	3.8	5.5	
		5000 - 6000	-	4.2	6.0	
		6000 - 7200	-	4.5	6.5	
		7200 - 8500	-	5.5	7.0	
Isolation	Between ports J1 & J4	2 - 700	82	105	-	dB
		700 - 2500	72	90	-	
		2500 - 5000	53	73	-	
		5000 - 8500	49	62	-	
	COM to any terminated port	2 - 700	82	105	-	
		700 - 2500	77	95	-	
		2500 - 5000	58	76	-	
		5000 - 6000	54	64	-	
		6000 - 7200	50	64	-	
		7200 - 8500	45	55	-	
	Disconnected state (COM port open) ¹ : COM to J2, J3, or J4	2 - 700	82	105	-	
		700 - 2500	77	95	-	
		2500 - 5000	58	76	-	
		5000 - 6000	54	64	-	
		6000 - 7200	50	64	-	
		7200 - 8500	45	55	-	
	Disconnected state (COM port open) ¹ : COM to J1	2 - 700	42	60	-	
		700 - 2500	33	44	-	
		2500 - 5000	28	34	-	
		5000 - 7200	25	32	-	
7200 - 8000		24	29	-		
8000 - 8500		23	28	-		
Return loss	COM port (active states)	2 - 700	-	15.5	-	dB
		700 - 5000	-	19.0	-	
		5000 - 6000	-	17.5	-	
		6000 - 7200	-	16.5	-	
		7200 - 8000	-	12.0	-	
		8000 - 8500	-	11.0	-	

1. In the "disconnected" state, COM is open (reflective), with ports J1-4 internally terminated. COM to J1 isolation is lower than the other paths due to the internal switch configuration (refer to block diagram for details).



ELECTRICAL SPECIFICATIONS (CONTINUED) AT -10 TO 60°C

Parameter	Ports	Condition (MHz)	Min.	Typ.	Max.	Unit	
Return loss	Any port connected to COM	2 - 700	-	15.5	-	dB	
		700 - 5000	-	19.0	-		
		5000 - 6000	-	17.5	-		
		6000 - 7200	-	14.0	-		
		7200 - 8000	-	13.0	-		
	Any terminated port	8000 - 8500	-	11.5	-		
		2 - 2500	-	23.0	-		
		2500 - 5000	-	21.0	-		
		5000 - 7200	-	19.0	-		
		7200 - 8000	-	17.0	-		
Power input @1 dB compression ^{2,3,4}	COM to any active port	8000 - 8500	-	14.5	-		
		100 - 8500	-	+35	-		
IP3 ^{4,5}	COM to any active port	100 - 6000	-	+55	-	dBm	
		6000 - 8500	-	+50	-		
Transition time ⁶	-	-	-	200	300	ns	
Minimum dwell time ⁷	High-speed mode	-	-	5	-	μs	
Switching time (USB) ⁸	-	-	-	2	-	ms	
Supply voltage (Vcc)	USB or D-Sub port	-	4.75	5	5.25	V _{DC}	
Supply current (Icc)		-	-	30	50	mA	
Operating RF input power ⁹	Total on any through path (bi-directional)	Cold switching	2-50	-	-	Note 2	dBm
			50-6000	-	-	+30	
			6000-8500	-	-	+29	
	Per port (COM & J1 - J4)	Hot switching	2-30	-	-	Note 3	
			30-8500	-	-	+24	
	Per terminated port (J1 - J4)	Into internal termination	2-30	-	-	Note 3	
30-8500			-	-	+24		

2. Max power at through path derates linearly from +30 dBm @ 50 MHz to +18 dBm @ 2 MHz.

3. Max power into termination derates linearly from +24 dBm @ 30 MHz to +18 dBm @ 2 MHz.

4. Compression and IP3 may degrade below 100 MHz.

5. IP3 tested with 1 MHz span between signals, +5 dBm per tone.

6. Transition time spec represents the time that the RF signal paths are interrupted during switching and thus is specified without communication delays.

7. Minimum dwell time is the shortest time that can be achieved between 2 switch transitions when programming an automated switch sequence.

8. Switching time(USB) is the time from issuing a single software command via USB to the switch state changing. The most significant factor is the host PC, influenced by CPU load and USB protocol. The time shown is an estimate for a medium CPU load and USB 2.0 connection.

9. The switch can tolerate the max cold switching power on the active path simultaneously with the max internal termination power on every terminated port.

ABSOLUTE MAXIMUM RATINGS ¹⁰

Operating temperature	-10°C to 60°C
Storage temperature	-20°C to 85°C
DC supply voltage max @ USB and pin 4 of D-sub	6V
Voltage on I ² C control pins (1 & 2 in D-sub)	3.6V
Voltage on address pins (6 - 8 in D-sub)	3.6V
DC voltage @ RF ports	16V

10. Permanent damage may occur if any of these limits are exceeded. Operating in the range between operating power limits and absolute maximum ratings for extended periods of time may result in reduced life and reliability.



TYPICAL PERFORMANCE CURVES

Insertion Loss over Temperature (J1 Active)

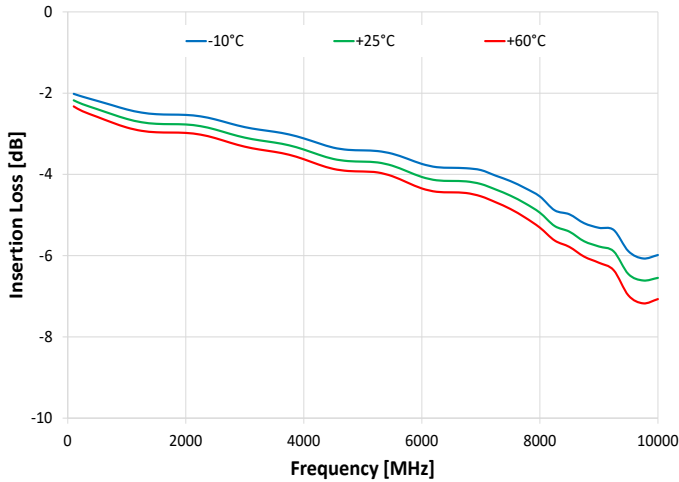

Insertion Loss J1 - J4 Active

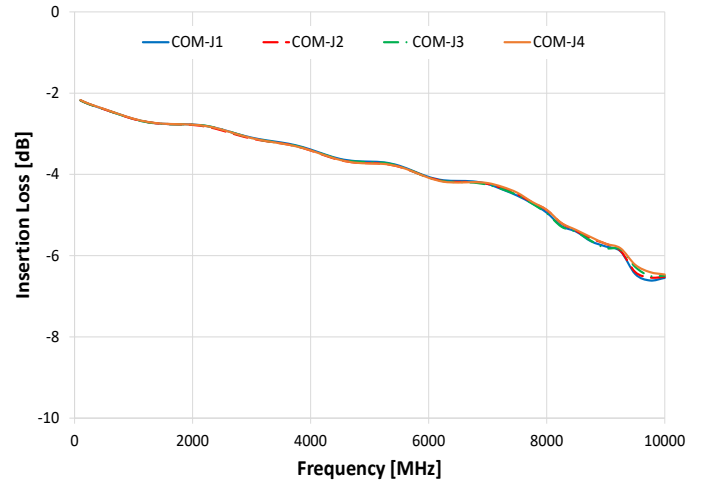

Isolation Com to J1 (J2 Active)

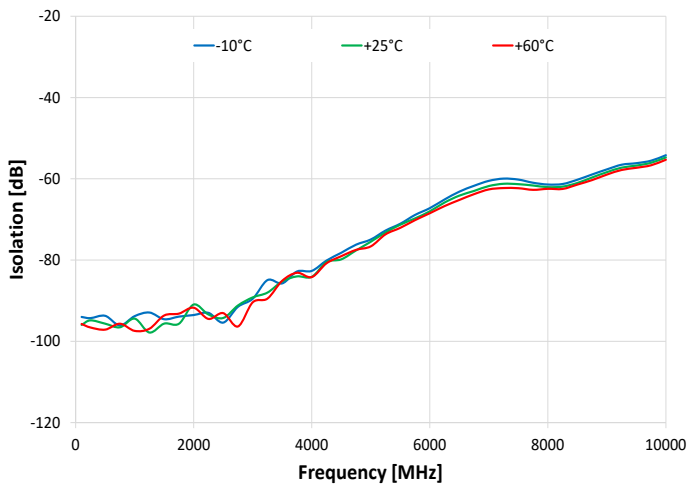

Isolation Com to J3 (J4 Active)

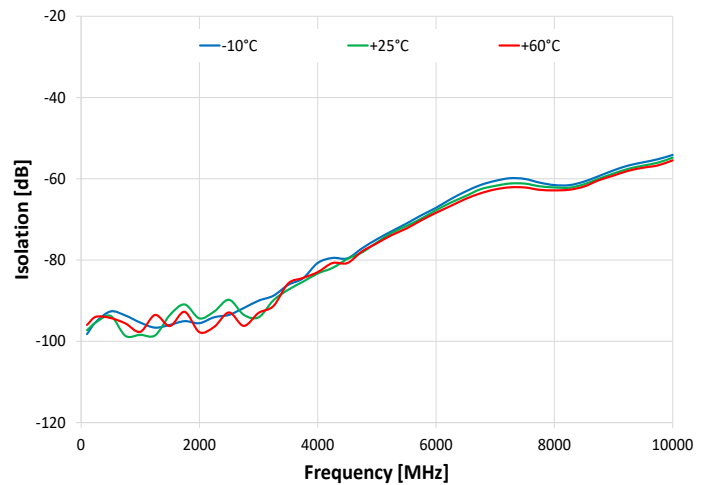

Isolation J2 to J3 (J2 Active)

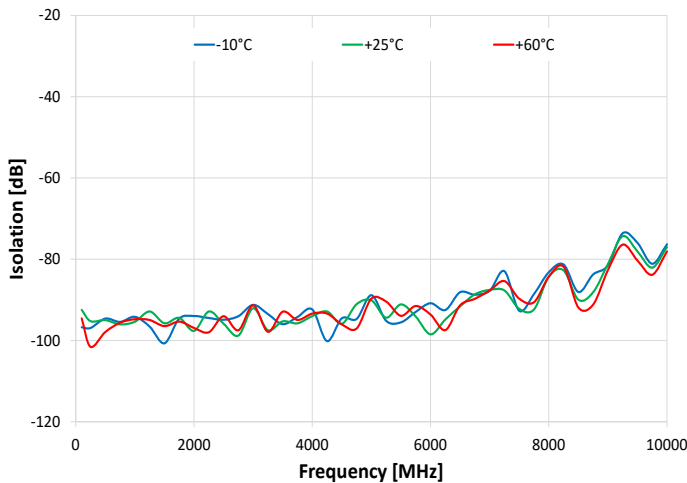

Isolation J3 to J4 (J3 Active)

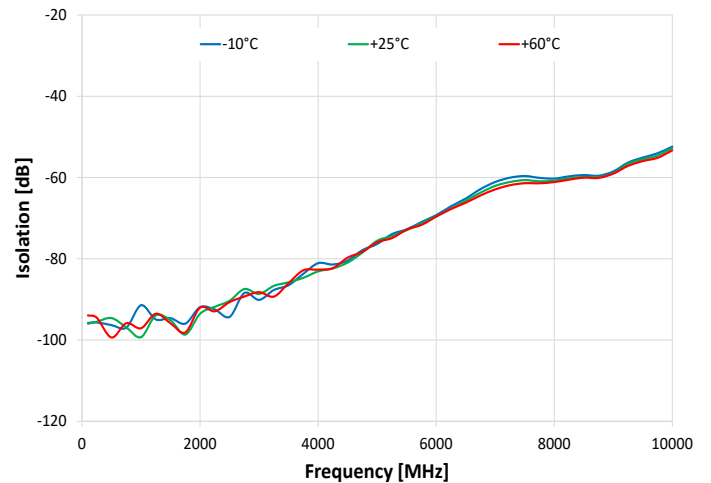



TYPICAL PERFORMANCE CURVES (CONTINUED)

Return Loss @ COM over Temperature (J1 Active)

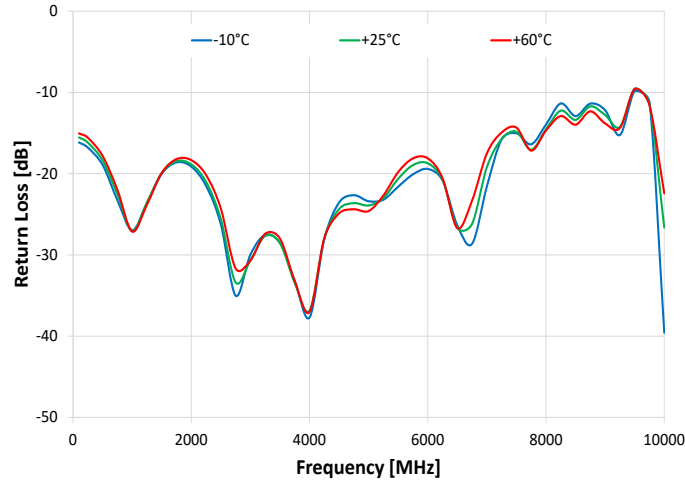

Return Loss @ J1 over Temperature (J1 Active)

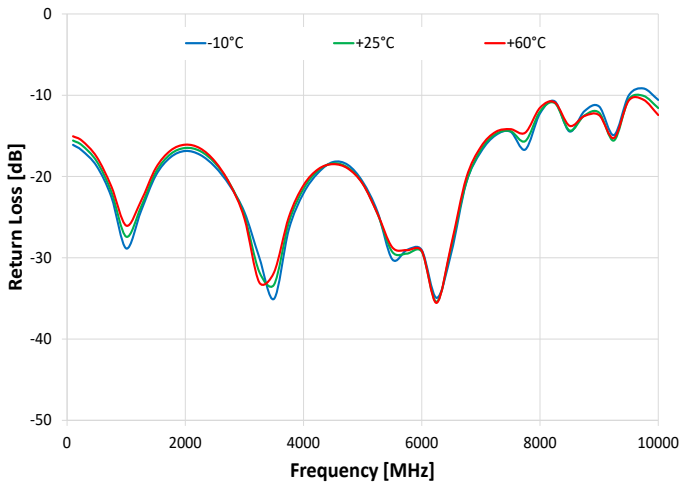

Return Loss @ J1 over Temperature (J1 Terminated)

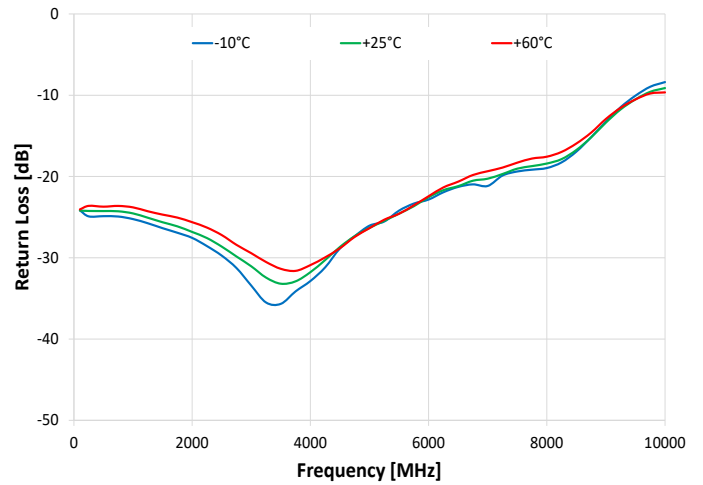

Return Loss @ Active ports (J1- J4 Active)

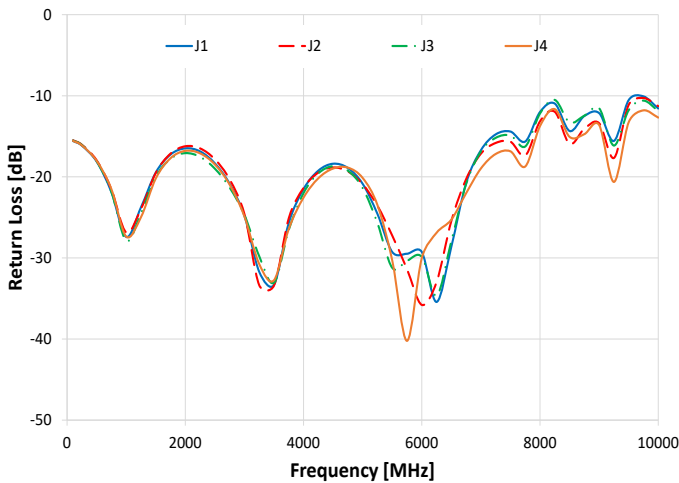

Return Loss @ Terminated ports (J1 - J4 Terminated)

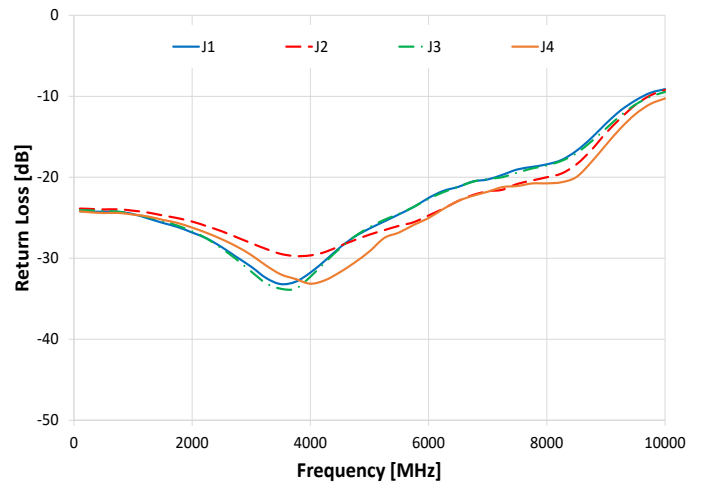



CONTROL INTERFACES

USB control	Supported protocols	HID (Human Interface Device) - Full-speed
	Min communication time ¹¹	3 ms typ (full transmit/receive cycle)
I ² C control	Refer to I ² C Communication Parameters section for more details.	

11. USB min communication time is based on the polling interval of the USB HID protocol (1 ms polling interval, 64 bytes per packet), medium CPU load and no other high speed USB devices using the USB bus.

SOFTWARE & DOCUMENTATION

Mini-Circuits' full software and support package including user guide, Windows GUI, API, programming manual and examples can be downloaded free of charge (refer to the last page for the download path).

A comprehensive set of software control options is provided:

- GUI for Windows – Simple software interface for control via Ethernet and USB.
- Programming / automation via USB:
 - DLL files provide a full API for Windows with a set of intuitive functions which can be implemented in any programming environment supporting .Net Framework or ActiveX.
 - Direct USB programming is possible in any other environment (not supporting .Net or ActiveX).

Please contact testsolutions@minicircuits.com for support.

MINIMUM SYSTEM REQUIREMENTS

GUI	Windows 7 or later
USB API DLL	Windows 7 or later and programming environment with ActiveX or .NET support
USB Direct Programming	Linux, Windows 7 or later
I ² C	Any computer with a suitable I/O port
Hardware	Intel i3 (or equivalent) or later



GRAPHICAL USER INTERFACE (GUI) FOR WINDOWS - KEY FEATURES

- Connect via USB
- Run GUI in "demo mode" to evaluate software without a hardware connection

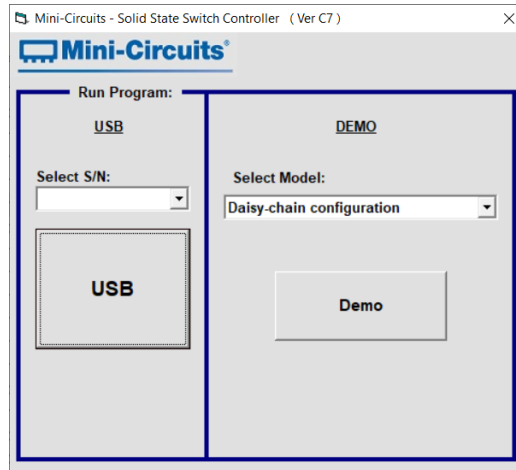

- View and set switch states at the click of a button
- Configure and run timed switching sequences

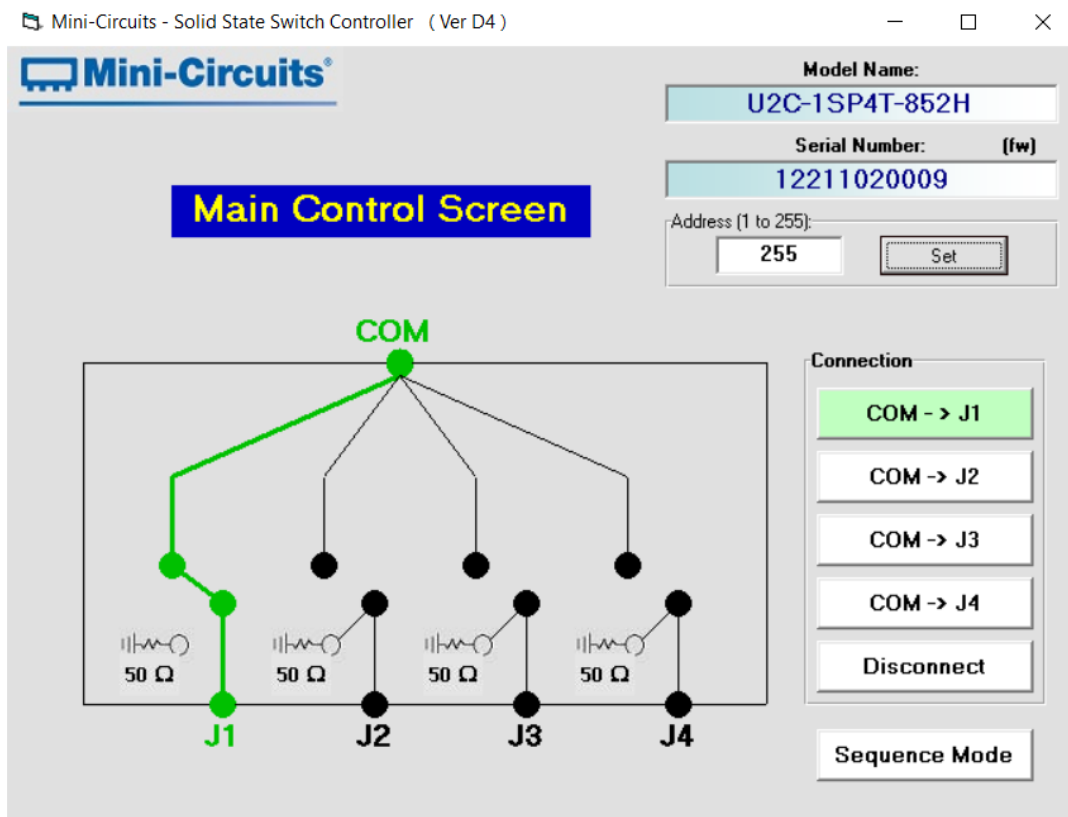

I²C COMMUNICATIONS PARAMETERS

Parameter	Conditions		Min.	Typ.	Max.	Units
Voltage levels	Logic low voltage	Input	0	-	0.8	V
	Logic high voltage	Input	2.0	-	3.3	
Clock frequency	-		-	-	400	kHz

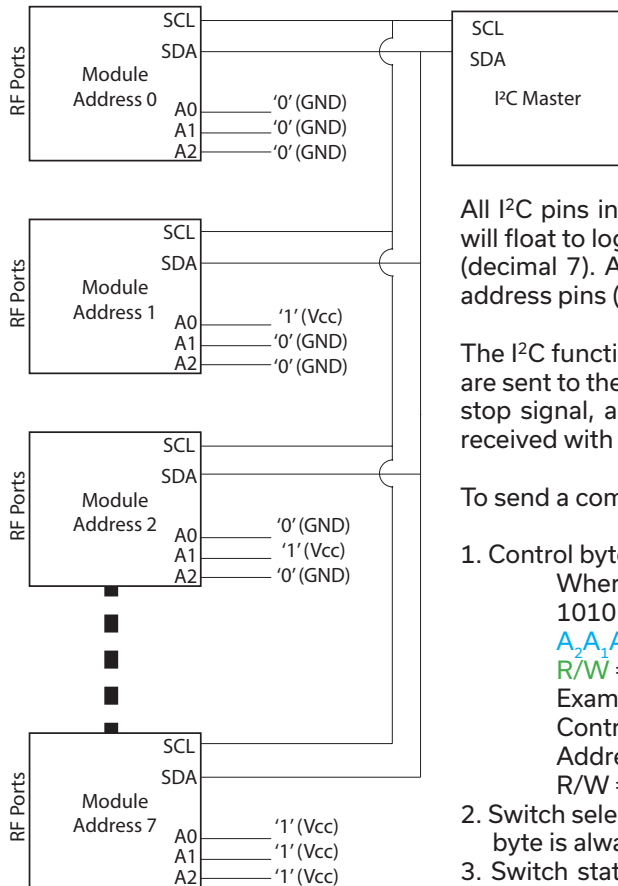

The I²C is a short-range synchronous communication protocol for simple 2-wire communication with slave devices using clock (SCL) and data (SDA) connections. The U2C-1SP4T-852H interface also includes 3 address pins (A0, A1 and A2), allowing up to 8 switches to be controlled independently from a single master with shared SDA and SCL connections..

All I²C pins in the U2C-1SP4T-852H are connected to an internal pullup resistor so will float to logic 1 when disconnected. This sets a default address of 111 (decimal 7). Addresses from 0 to 7 can be set by externally grounding the relevant address pins (A0, A1 and A2).

The I²C functionality is limited to setting or reading switch states. Control sequences are sent to the switch in several bytes on the data connection, enclosed by a start and stop signal, and clocked at up to 400 kHz. The switch will acknowledge each byte received with a single "ACK" bit (logic 1) on the same data connection.

To send a command to the switch 3 bytes will be sent:

1. Control byte (1010 $A_2A_1A_0$ R/W)

Where:

1010 = Control code for U2C-1SP4T-852H

$A_2A_1A_0$ = 3-bit address for the U2C-1SP4T-852H switch module

R/W = Read / write select bit ('0' to write or '1' to read)

Example:

Control byte = 10101000

Address = 100 (binary) = 4 (decimal)

R/W = 0 (write to switch)

2. Switch selector byte (00000001) - U2C-1SP4T-852H contains only 1 switch so this byte is always 00000001.
3. Switch state byte (00000XYZ) - The switch state, represented by a binary string according to the truth table below.

Switch state	Switch state byte	Port behavior				
		COM	J1	J2	J3	J4
Disconnected	0000 0000	Reflective	Terminated Internally (50Ω)	Terminated Internally (50Ω)	Terminated Internally (50Ω)	Terminated Internally (50Ω)
COM -> 1	0000 0001	Connected to J1	Connected to COM	Terminated Internally (50Ω)	Terminated Internally (50Ω)	Terminated Internally (50Ω)
COM -> 2	0000 0010	Connected to J2	Terminated Internally (50Ω)	Connected to COM	Terminated Internally (50Ω)	Terminated Internally (50Ω)
COM -> 3	0000 0010	Connected to J3	Terminated Internally (50Ω)	Terminated Internally (50Ω)	Connected to COM	Terminated Internally (50Ω)
COM -> 4	0000 0010	Connected to J4	Terminated Internally (50Ω)	Terminated Internally (50Ω)	Terminated Internally (50Ω)	Connected to COM

In I²C protocol the Data line may not change states while the Clock is high, except for the start and stop signals which enclose each sequence of bytes. While the Clock is high a falling edge (transition from logic 1 to logic 0) signifies the start of a sequence, while a rising edge (transition from logic 0 to logic 1) signifies a stop signal. All other transitions must occur while the clock is low.



SP4T Switch

U2C-1SP4T-852H

SETTING SWITCH STATE VIA I²C

The I²C communication sequence to set the switch state is:

1. Start signal
2. Send control byte (write mode)
3. Receive ACK response from switch
4. Send switch selector byte
5. Receive ACK response from switch
6. Send switch state byte
7. Receive ACK response from switch
8. Stop signal

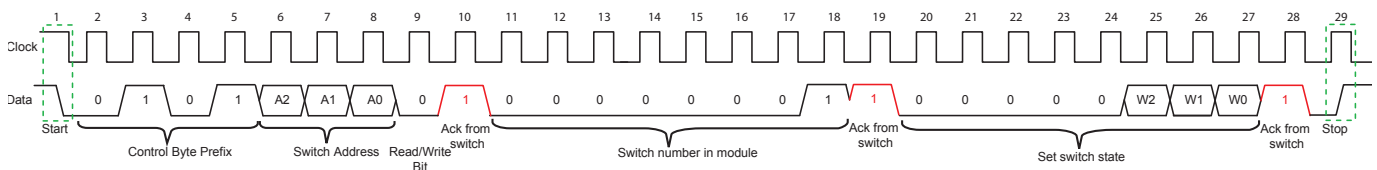

Legend:

Signal from master to switch _____
 Signal from switch to master _____

READING SWITCH STATE VIA I²C

The I²C communication sequence to set the switch state is:

- | | |
|-------------------------------------|-------------------------------------|
| 1. Start signal | 7. Start signal |
| 2. Send control byte (write mode) | 8. Send control byte (read mode) |
| 3. Receive ACK response from switch | 9. Receive ACK response from switch |
| 4. Send switch selector byte | 10. Receive current switch state |
| 5. Receive ACK response from switch | 11. Stop signal |
| 6. Stop signal | |

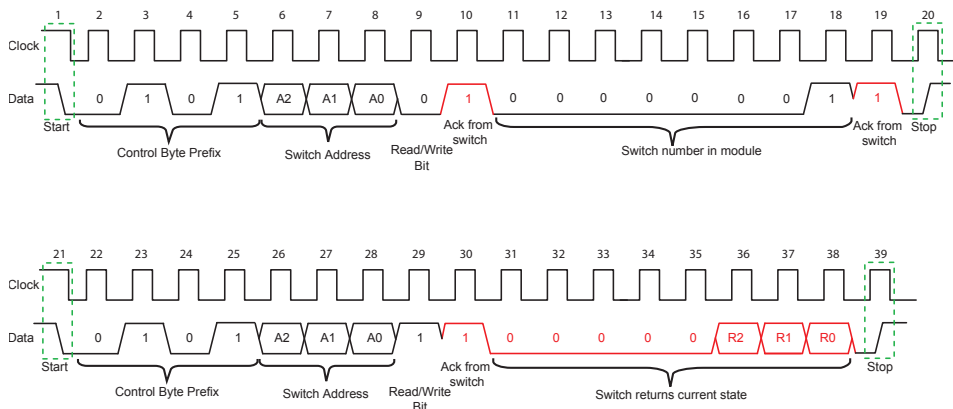

Legend:

Signal from master to switch _____
 Signal from switch to master _____



SP4T Switch

U2C-1SP4T-852H

BLOCK DIAGRAM

Power supply is needed from only one port at a time. Power can be supplied via USB or I²C port regardless of the control interface used.

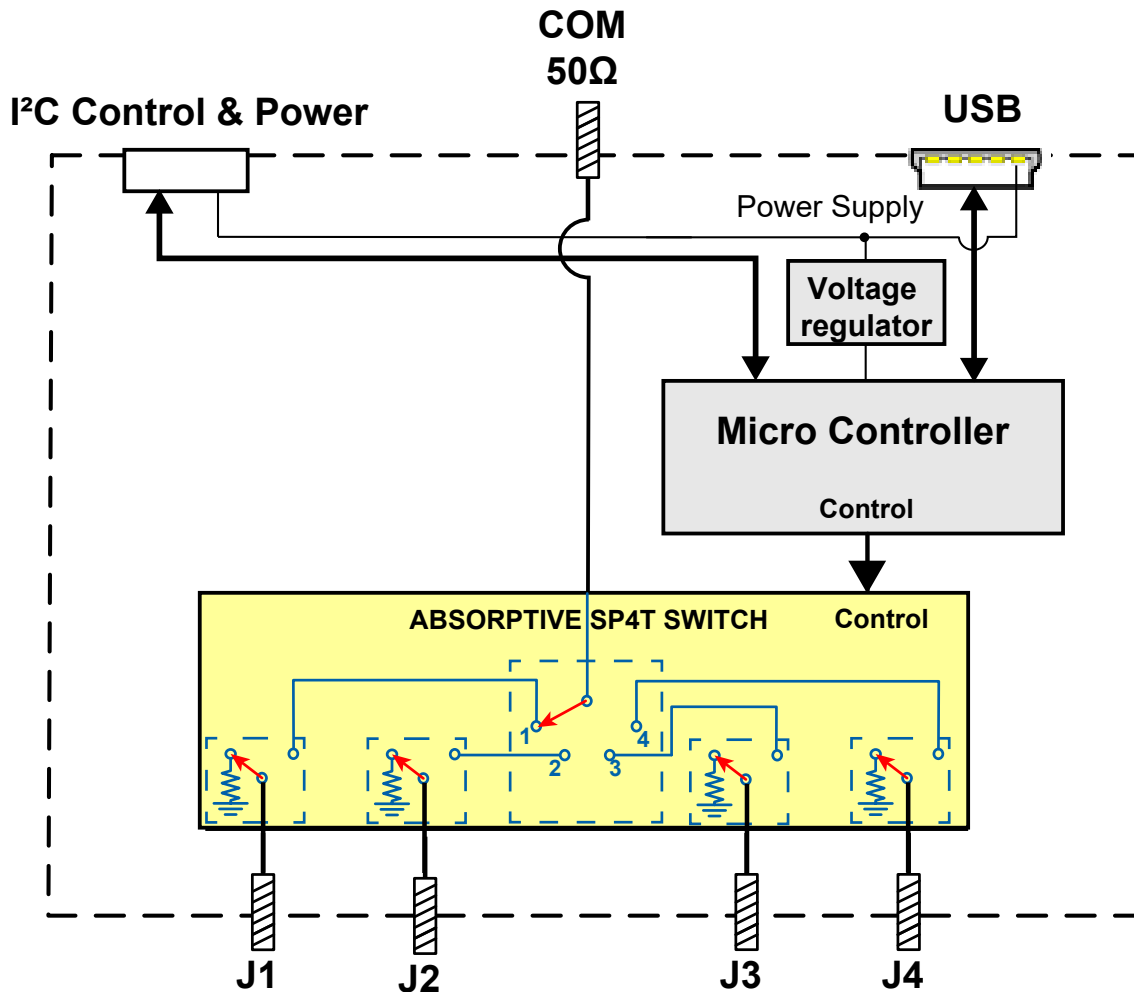

Switch in disconnected state

SWITCH STATE TABLE

State	Switch path
0	All ports disconnected
1	Com to 1
2	Com to 2
3	Com to 3
4	Com to 4

CONNECTIONS

Port name	Connector type
RF ports (COM & 1 to 4)	(SMA female)
USB	(USB type Mini-B receptacle)
I ² C	(9 pin D-sub female)



SP4T Switch

U2C-1SP4T-852H

CASE STYLE DRAWING (RB2502)

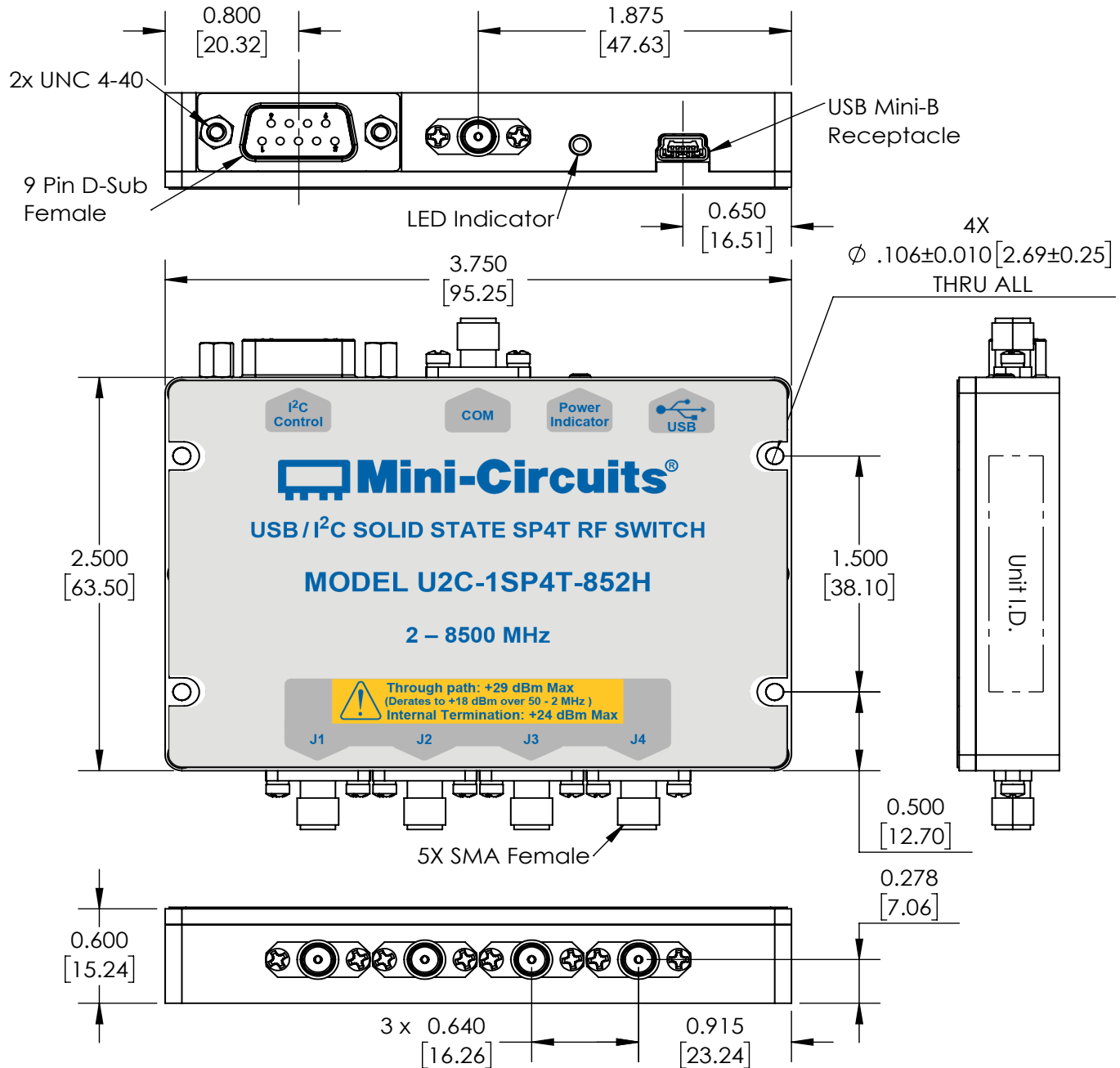

NOTES:

1. Case material: Aluminum alloy.
2. Case Finish: Nickel Plate.
3. Dimensions: Inches [mm]. Tolerances 2 Pl. ±.03 inch; 3 Pl. ±.015 inch.
4. Weight: 220 grams
5. Marking may contain other features or characters for internal lot control.



SP4T Switch

U2C-1SP4T-852H

RECOMMENDED ACCESSORIES

U2C-1SP4T-852H includes a standard 9 pin D-Sub connector for I²C control applications. An optional shielded control cable is available for implementing custom cable harnesses. D-SUB9-MPT-3+ has a D-Sub connector for mating to U2C-1SP4T-852H and bare wires (pig tail) on the other end. The cable is 36 inches (0.9 meter) long using 28 AWG wires.

CONTROL CABLE D-SUB9-MPT-3+

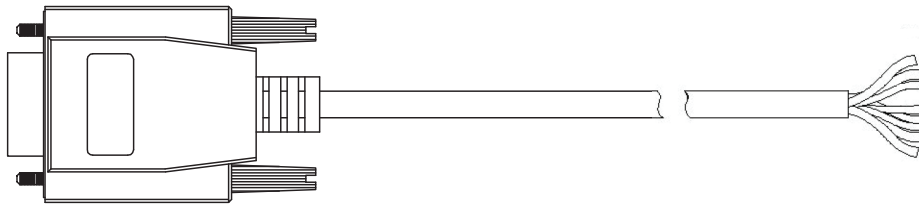

Pin Number	Function	Description	Pigtail Wire Color
1	SDA	I ² C Data	BLACK
2	SCL	I ² C Clock	BROWN
3	GND	Ground connection	RED
4	Vcc	Supply Voltage	ORANGE
5	GND	Ground connection	YELLOW
6	A0	Address bit 0 (LSB)	GREEN
7	A1	Address bit 1	BLUE
8	A2	Address bit 2 (MSB)	PURPLE
9	GND	Ground connection	WHITE



USB | I²C

SP4T Switch

SOLID STATE

U2C-1SP4T-852H

Mini-Circuits

50Ω

2 to 8500 MHz

SMA female

ADDITIONAL DETAILED MODEL INFORMATION IS AVAILABLE ON OUR WEBSITE

Ordering information	https://www.minicircuits.com/WebStore/dashboard.html?model=U2C-1SP4T-852H
Performance data & graphs	https://www.minicircuits.com/pages/s-params/U2C-1SP4T-852H_VIEW.pdf https://www.minicircuits.com/pages/s-params/U2C-1SP4T-852H_GRAPHS.pdf
Case style	https://www.minicircuits.com/case_style/RB2502.pdf
Software, user guide & programming manual	https://www.minicircuits.com/softwaredownload/solidstate.html
Environmental rating	https://www.minicircuits.com/pcb/ENV55.pdf
Regulatory compliance	Refer to user guide for compliance information  https://www.minicircuits.com/app/AN49-012.pdf
Support	testsolutions@minicircuits.com

INCLUDED ACCESSORIES

Photo	Part No.	Description
	MUSB-CBL-3+	3.3 ft (1.0 m) USB Cable: USB type A (Male) to USB type Mini-B (Male)

OPTIONAL ACCESSORIES

Part No.	Description
MUSB-CBL-3+ (Spare)	3.3 ft (1.0 m) USB Cable: USB type A (Male) to USB type Mini-B (Male)
MUSB-CBL-7+	6.6 ft (2.0 m) USB Cable: USB type A (Male) to USB type Mini-B (Male)
D-SUB9-MPT-3+	3.0 ft (1.0 m) I ² C Cable: 9 pin D-sub (Male) to Pig-Tail (Bare wires)
USB-AC/DC-5	AC/DC +5V power adaptor with USB connector ^{12, 13}

12. The power adaptor may be used to provide additional power via USB port when connecting several units in I²C control.

13. Includes power plugs for US, UK, EU, IL, AU & China. Plugs for other countries are also available. If you need a power cord for a country not listed please contact testsolutions@minicircuits.com

NOTES:

- A. Performance and quality attributes and conditions not expressly stated in this specification document are intended to be excluded and do not form a part of this specification document.
- B. Electrical specifications and performance data contained in this specification document are based on Mini-Circuit's applicable established test performance criteria and measurement instructions.
- C. The parts covered by this specification document are subject to Mini-Circuits standard limited warranty and terms and conditions (collectively, "Standard Terms"); Purchasers of this part are entitled to the rights and benefits contained therein. For a full statement of the Standard Terms and the exclusive rights and remedies thereunder, please visit Mini-Circuits' website at <https://www.minicircuits.com/terms/viewterm.html>



SP4T Switch

U2C-1SP4T-852H

Typical Performance Data

Test Conditions: @ Temperature = -10°C, Pin = 8 dBm.

Freq. (MHz)	Insertion Loss (dB)			
	COM-J1	COM-J2	COM-J3	COM-J4
10	-1.89	-1.89	-1.89	-1.88
250	-2.09	-2.09	-2.09	-2.08
500	-2.19	-2.19	-2.19	-2.18
750	-2.30	-2.30	-2.30	-2.29
1000	-2.40	-2.41	-2.41	-2.40
1250	-2.48	-2.48	-2.48	-2.47
1500	-2.52	-2.52	-2.52	-2.51
1750	-2.53	-2.54	-2.53	-2.53
2000	-2.54	-2.55	-2.53	-2.54
2250	-2.57	-2.59	-2.57	-2.57
2500	-2.65	-2.68	-2.65	-2.65
2750	-2.75	-2.78	-2.75	-2.75
3000	-2.84	-2.87	-2.84	-2.84
3250	-2.90	-2.93	-2.91	-2.91
3500	-2.95	-2.98	-2.96	-2.96
3750	-3.02	-3.04	-3.03	-3.03
4000	-3.11	-3.14	-3.12	-3.13
4250	-3.23	-3.26	-3.23	-3.24
4500	-3.34	-3.36	-3.34	-3.36
4750	-3.40	-3.43	-3.40	-3.43
5000	-3.41	-3.45	-3.42	-3.45
5250	-3.43	-3.47	-3.44	-3.46
5500	-3.49	-3.52	-3.49	-3.50
5750	-3.61	-3.63	-3.60	-3.61
6000	-3.74	-3.76	-3.74	-3.74
6250	-3.82	-3.85	-3.83	-3.83
6500	-3.84	-3.87	-3.85	-3.86
6750	-3.85	-3.86	-3.85	-3.85
7000	-3.89	-3.89	-3.89	-3.86
7250	-4.03	-4.00	-4.02	-3.96
7500	-4.16	-4.13	-4.17	-4.08
7750	-4.34	-4.33	-4.36	-4.30
8000	-4.54	-4.51	-4.61	-4.48
8250	-4.88	-4.84	-4.94	-4.82
8500	-4.98	-4.98	-4.99	-4.95
8750	-5.20	-5.14	-5.16	-5.08
9000	-5.31	-5.22	-5.27	-5.20
9250	-5.37	-5.33	-5.27	-5.27
9500	-5.89	-5.78	-5.66	-5.64
9750	-6.07	-5.91	-5.89	-5.82
10000	-5.98	-5.89	-5.88	-5.85

SP4T Switch

U2C-1SP4T-852H

Typical Performance Data

Test Conditions: @ Temperature = -10°C, Pin = 8 dBm.

Freq. (MHz)	Return Loss, Active ports (dB)					R. Loss, Internally terminated ports (dB)			
	COM	J1	J2	J3	J4	J1	J2	J3	J4
10	-15.81	-15.83	-15.77	-15.79	-15.85	-24.58	-24.31	-24.49	-24.69
250	-16.79	-16.79	-16.66	-16.70	-16.78	-24.90	-24.49	-24.65	-25.03
500	-18.93	-18.72	-18.63	-18.72	-18.66	-24.88	-24.57	-24.85	-25.15
750	-23.28	-22.54	-22.37	-22.58	-22.12	-24.92	-24.97	-25.02	-25.22
1000	-26.97	-28.85	-28.50	-29.12	-28.75	-25.24	-25.05	-25.07	-25.40
1250	-23.61	-24.27	-24.55	-24.96	-25.66	-25.75	-24.85	-25.57	-25.54
1500	-20.02	-19.88	-19.91	-20.33	-20.70	-26.36	-25.22	-26.05	-26.06
1750	-18.61	-17.63	-17.52	-18.16	-18.21	-26.92	-25.64	-26.80	-26.83
2000	-19.13	-16.86	-16.71	-17.61	-17.21	-27.55	-26.57	-27.96	-27.39
2250	-21.51	-17.33	-16.90	-17.96	-17.47	-28.56	-27.36	-29.49	-28.36
2500	-26.26	-18.79	-18.03	-19.05	-18.69	-29.73	-28.09	-30.56	-28.93
2750	-35.01	-21.11	-20.26	-20.89	-20.73	-31.26	-28.99	-32.01	-30.01
3000	-29.95	-24.39	-23.90	-23.82	-24.09	-33.42	-29.78	-33.85	-31.21
3250	-27.55	-29.93	-31.76	-29.45	-29.42	-35.50	-30.23	-34.31	-32.91
3500	-28.53	-35.05	-34.14	-36.43	-34.87	-35.67	-29.62	-34.18	-33.24
3750	-33.19	-26.54	-25.33	-26.04	-27.43	-34.13	-29.75	-31.82	-33.64
4000	-37.70	-22.04	-21.70	-22.53	-22.93	-32.86	-29.58	-32.40	-33.58
4250	-28.06	-19.52	-20.02	-20.49	-20.53	-31.18	-29.84	-31.91	-34.44
4500	-23.55	-18.22	-19.15	-19.22	-18.90	-28.85	-29.58	-31.25	-32.72
4750	-22.65	-18.57	-19.18	-19.16	-18.42	-27.34	-29.01	-29.43	-31.13
5000	-23.40	-20.64	-20.53	-20.18	-19.65	-26.05	-28.18	-28.54	-29.21
5250	-23.20	-24.32	-23.00	-22.99	-22.25	-25.54	-27.54	-27.65	-28.19
5500	-21.60	-30.18	-26.41	-28.92	-28.45	-24.20	-27.35	-26.36	-26.83
5750	-20.08	-29.03	-32.60	-40.15	-51.84	-23.33	-26.85	-25.14	-26.21
6000	-19.42	-29.06	-36.15	-29.35	-31.42	-22.83	-26.06	-22.97	-26.03
6250	-20.84	-34.93	-28.91	-30.10	-25.48	-21.94	-25.65	-22.05	-24.42
6500	-26.36	-29.36	-25.49	-29.10	-24.09	-21.28	-23.51	-20.64	-23.32
6750	-28.63	-20.83	-20.86	-22.39	-21.45	-20.97	-22.96	-20.12	-22.88
7000	-21.56	-16.97	-17.84	-17.53	-19.15	-21.16	-21.27	-19.07	-21.97
7250	-15.77	-14.91	-16.27	-15.07	-17.19	-19.88	-21.70	-19.16	-21.61
7500	-15.03	-14.49	-16.10	-14.08	-16.63	-19.38	-21.22	-18.24	-20.77
7750	-16.38	-16.68	-18.37	-16.34	-20.05	-19.16	-20.13	-18.31	-20.78
8000	-13.95	-12.23	-13.05	-11.65	-13.76	-18.96	-19.54	-17.62	-20.17
8250	-11.36	-10.76	-11.45	-10.03	-11.33	-18.26	-19.11	-17.41	-20.63
8500	-12.91	-14.46	-15.68	-13.57	-15.19	-16.94	-17.72	-16.60	-19.95
8750	-11.38	-11.96	-13.34	-12.62	-14.58	-15.16	-16.24	-15.76	-18.15
9000	-12.19	-11.38	-13.04	-11.93	-13.26	-13.23	-14.34	-14.45	-16.07
9250	-15.24	-14.91	-17.96	-17.13	-19.78	-11.46	-12.78	-13.01	-13.84
9500	-9.83	-10.03	-11.24	-12.14	-12.89	-10.05	-11.18	-11.52	-12.01
9750	-11.22	-9.17	-10.19	-10.35	-11.14	-8.95	-10.00	-10.28	-10.80
10000	-39.57	-10.57	-11.25	-11.61	-11.95	-8.38	-9.20	-9.53	-9.77

SP4T Switch

U2C-1SP4T-852H

Typical Performance Data

Test Conditions: @ Temperature = -10°C, Pin = 8 dBm.

Freq. (MHz)	Isolation, Active states (dB)				Isolation, Disconnected states (dB)			
	COM-1	COM-3	J2-J3	J3-J4	COM-1	COM-2	COM-3	COM-4
10	-98.02	-94.55	-95.12	-98.25	-73.80	-99.05	-99.17	-98.46
250	-94.29	-95.23	-96.92	-95.67	-59.26	-95.54	-97.37	-95.03
500	-93.72	-92.64	-94.62	-96.33	-53.95	-96.97	-96.93	-99.52
750	-96.08	-93.65	-95.43	-96.94	-50.58	-94.29	-96.96	-93.60
1000	-93.80	-95.39	-94.18	-91.43	-48.20	-94.83	-94.50	-94.97
1250	-92.91	-96.63	-96.59	-94.93	-46.55	-96.41	-94.78	-93.94
1500	-94.56	-95.96	-100.69	-94.63	-45.38	-96.35	-97.08	-98.83
1750	-93.91	-95.03	-94.60	-95.96	-44.36	-94.53	-89.75	-97.03
2000	-93.53	-95.53	-93.98	-91.92	-43.29	-92.75	-86.79	-96.82
2250	-93.00	-94.07	-94.47	-92.48	-42.02	-97.21	-87.02	-94.55
2500	-95.39	-93.50	-94.90	-94.30	-40.67	-91.34	-86.11	-93.68
2750	-91.50	-91.80	-94.03	-88.42	-39.44	-89.47	-84.97	-94.73
3000	-89.52	-89.99	-91.24	-90.11	-38.65	-87.29	-84.92	-92.44
3250	-84.93	-88.78	-93.50	-87.69	-38.30	-89.41	-91.39	-97.96
3500	-85.74	-86.11	-95.98	-86.50	-38.02	-88.47	-84.55	-91.68
3750	-82.81	-84.50	-94.21	-83.69	-37.56	-86.07	-75.72	-92.85
4000	-82.67	-80.71	-92.37	-81.08	-36.83	-82.99	-74.52	-96.26
4250	-80.12	-79.48	-100.15	-81.41	-35.96	-83.65	-74.00	-94.67
4500	-78.20	-79.58	-94.54	-80.45	-35.19	-82.85	-73.75	-93.37
4750	-76.21	-77.10	-94.70	-77.88	-34.82	-83.15	-74.03	-93.24
5000	-74.94	-74.88	-88.85	-76.37	-34.87	-82.04	-77.34	-94.55
5250	-72.73	-72.90	-95.17	-73.94	-34.95	-83.27	-84.53	-91.89
5500	-71.05	-71.01	-95.54	-72.75	-34.81	-82.24	-71.83	-94.54
5750	-68.89	-68.99	-92.96	-70.96	-34.37	-84.60	-68.26	-92.49
6000	-67.22	-67.13	-90.84	-69.26	-33.78	-85.97	-67.30	-91.59
6250	-65.09	-64.98	-92.50	-67.09	-33.37	-84.59	-67.00	-97.84
6500	-63.16	-63.12	-88.12	-65.17	-33.26	-80.53	-67.92	-94.78
6750	-61.71	-61.54	-88.73	-62.86	-33.27	-75.30	-69.89	-93.40
7000	-60.51	-60.51	-87.78	-61.10	-33.13	-71.26	-74.02	-90.17
7250	-59.95	-59.86	-82.96	-60.04	-32.68	-68.35	-67.04	-95.69
7500	-60.19	-60.03	-92.70	-59.64	-31.98	-65.61	-62.29	-92.14
7750	-60.97	-60.94	-88.57	-60.09	-30.97	-63.30	-60.71	-92.33
8000	-61.41	-61.55	-83.21	-60.27	-30.84	-62.43	-62.36	-91.53
8250	-61.28	-61.57	-81.30	-59.72	-29.70	-60.57	-62.16	-89.78
8500	-60.23	-60.70	-88.06	-59.39	-28.58	-58.88	-55.21	-84.45
8750	-58.93	-59.34	-83.76	-59.56	-28.78	-58.52	-55.69	-84.71
9000	-57.68	-57.92	-81.54	-58.51	-27.95	-57.04	-56.84	-85.71
9250	-56.53	-56.74	-73.61	-56.32	-27.07	-55.58	-52.53	-79.99
9500	-56.16	-55.95	-75.97	-55.09	-27.85	-55.56	-51.37	-79.06
9750	-55.54	-55.19	-81.12	-54.03	-27.94	-55.10	-51.94	-79.19
10000	-54.19	-54.12	-76.32	-52.39	-27.27	-53.78	-52.86	-75.65

SP4T Switch

U2C-1SP4T-852H

Typical Performance Data

Test Conditions: @ Temperature = +25°C, Pin = 8 dBm.

Freq. (MHz)	Insertion Loss (dB)			
	COM-J1	COM-J2	COM-J3	COM-J4
10	-2.05	-2.05	-2.05	-2.04
250	-2.27	-2.27	-2.28	-2.27
500	-2.39	-2.40	-2.40	-2.39
750	-2.52	-2.52	-2.52	-2.51
1000	-2.63	-2.64	-2.64	-2.63
1250	-2.72	-2.72	-2.72	-2.71
1500	-2.75	-2.75	-2.76	-2.75
1750	-2.76	-2.77	-2.77	-2.76
2000	-2.77	-2.78	-2.77	-2.78
2250	-2.81	-2.83	-2.81	-2.82
2500	-2.90	-2.92	-2.89	-2.90
2750	-3.00	-3.03	-3.00	-3.01
3000	-3.10	-3.12	-3.11	-3.11
3250	-3.16	-3.18	-3.18	-3.18
3500	-3.22	-3.24	-3.23	-3.24
3750	-3.28	-3.31	-3.30	-3.31
4000	-3.39	-3.41	-3.40	-3.41
4250	-3.51	-3.54	-3.53	-3.53
4500	-3.62	-3.65	-3.63	-3.64
4750	-3.67	-3.71	-3.68	-3.71
5000	-3.69	-3.72	-3.70	-3.73
5250	-3.71	-3.74	-3.72	-3.74
5500	-3.79	-3.81	-3.80	-3.81
5750	-3.92	-3.94	-3.94	-3.94
6000	-4.06	-4.08	-4.08	-4.08
6250	-4.15	-4.16	-4.17	-4.18
6500	-4.16	-4.19	-4.19	-4.20
6750	-4.17	-4.19	-4.20	-4.19
7000	-4.24	-4.23	-4.26	-4.21
7250	-4.37	-4.34	-4.37	-4.31
7500	-4.52	-4.49	-4.51	-4.45
7750	-4.71	-4.69	-4.72	-4.68
8000	-4.94	-4.88	-4.96	-4.87
8250	-5.27	-5.20	-5.29	-5.20
8500	-5.41	-5.39	-5.42	-5.37
8750	-5.65	-5.58	-5.64	-5.55
9000	-5.77	-5.71	-5.82	-5.71
9250	-5.89	-5.88	-5.85	-5.82
9500	-6.45	-6.40	-6.28	-6.23
9750	-6.61	-6.54	-6.50	-6.41
10000	-6.55	-6.52	-6.49	-6.46

SP4T Switch

U2C-1SP4T-852H

Typical Performance Data

Test Conditions: @ Temperature = +25°C, Pin = 8 dBm.

Freq. (MHz)	Return Loss, Active ports (dB)					R. Loss, Internally terminated ports (dB)			
	COM	J1	J2	J3	J4	J1	J2	J3	J4
10	-15.12	-15.14	-15.09	-15.10	-15.15	-23.80	-23.54	-23.70	-23.87
250	-16.18	-16.15	-16.04	-16.08	-16.12	-24.24	-23.90	-24.07	-24.31
500	-18.38	-18.12	-17.96	-18.06	-18.03	-24.25	-23.97	-24.16	-24.41
750	-22.53	-21.90	-21.55	-21.87	-21.52	-24.28	-23.95	-24.24	-24.40
1000	-27.06	-27.40	-26.85	-27.89	-27.37	-24.54	-24.12	-24.54	-24.61
1250	-23.52	-23.75	-23.95	-24.52	-24.97	-25.07	-24.35	-24.92	-24.84
1500	-19.91	-19.47	-19.53	-19.99	-20.21	-25.63	-24.71	-25.39	-25.25
1750	-18.46	-17.24	-17.14	-17.77	-17.70	-26.13	-25.04	-25.97	-25.63
2000	-18.86	-16.49	-16.23	-17.07	-16.80	-26.82	-25.47	-26.68	-26.22
2250	-21.01	-16.87	-16.49	-17.54	-17.10	-27.57	-26.04	-27.58	-26.88
2500	-25.60	-18.34	-17.84	-18.99	-18.47	-28.62	-26.66	-28.80	-27.65
2750	-33.38	-20.86	-20.32	-21.34	-20.97	-29.84	-27.40	-30.14	-28.53
3000	-30.66	-24.82	-24.59	-24.70	-24.90	-31.05	-28.14	-31.65	-29.60
3250	-27.67	-31.71	-33.36	-29.78	-30.75	-32.43	-28.85	-33.08	-30.89
3500	-28.55	-33.31	-33.40	-33.05	-32.75	-33.19	-29.46	-33.76	-31.99
3750	-33.47	-25.67	-25.09	-26.53	-26.43	-32.89	-29.73	-33.75	-32.56
4000	-36.84	-21.51	-21.37	-22.00	-22.55	-31.77	-29.65	-32.28	-33.14
4250	-27.96	-19.24	-19.47	-19.57	-20.18	-30.28	-29.23	-30.49	-32.70
4500	-24.36	-18.38	-18.85	-18.69	-18.97	-28.66	-28.47	-28.77	-31.72
4750	-23.63	-18.91	-19.33	-19.24	-18.87	-27.33	-27.75	-27.30	-30.52
5000	-23.92	-20.86	-20.91	-21.39	-20.14	-26.33	-27.08	-26.17	-29.15
5250	-22.99	-24.58	-23.57	-25.71	-23.48	-25.45	-26.53	-25.25	-27.49
5500	-20.63	-29.27	-27.25	-31.22	-30.31	-24.57	-25.99	-24.51	-26.82
5750	-18.95	-29.48	-31.39	-30.35	-40.22	-23.66	-25.55	-23.65	-25.87
6000	-18.72	-29.26	-35.79	-29.87	-30.02	-22.55	-24.72	-22.67	-25.03
6250	-20.76	-35.43	-32.97	-34.65	-26.90	-21.68	-23.87	-21.84	-23.90
6500	-26.68	-28.61	-25.44	-27.90	-25.27	-21.19	-22.92	-21.18	-22.92
6750	-26.16	-20.77	-20.27	-20.89	-22.02	-20.52	-22.19	-20.55	-22.28
7000	-19.19	-16.72	-17.14	-16.87	-18.97	-20.27	-21.73	-20.21	-21.78
7250	-15.75	-14.77	-15.82	-15.19	-17.18	-19.69	-21.54	-19.98	-21.21
7500	-14.84	-14.42	-15.67	-14.90	-16.86	-19.03	-20.82	-19.43	-21.08
7750	-17.06	-15.64	-17.38	-16.25	-18.72	-18.72	-20.39	-18.91	-20.76
8000	-14.54	-11.99	-13.16	-12.18	-13.73	-18.40	-19.99	-18.54	-20.75
8250	-12.24	-10.97	-11.98	-10.52	-11.66	-17.86	-19.53	-17.97	-20.61
8500	-13.38	-14.35	-15.93	-13.28	-15.07	-16.73	-18.41	-17.04	-19.97
8750	-11.72	-12.50	-14.07	-12.45	-14.73	-15.18	-16.66	-15.60	-18.15
9000	-12.78	-12.15	-13.39	-11.55	-13.61	-13.36	-14.54	-13.98	-16.00
9250	-14.26	-15.57	-17.67	-16.14	-20.63	-11.74	-12.69	-12.36	-13.93
9500	-9.55	-10.53	-11.12	-11.78	-13.26	-10.51	-11.05	-11.01	-12.19
9750	-11.49	-10.08	-10.28	-10.60	-11.80	-9.57	-9.90	-10.06	-10.96
10000	-26.63	-11.57	-11.29	-11.87	-12.69	-9.12	-9.20	-9.46	-10.26

SP4T Switch

U2C-1SP4T-852H

Typical Performance Data

Test Conditions: @ Temperature = +25°C, Pin = 8 dBm.

Freq. (MHz)	Isolation, Active states (dB)				Isolation, Disconnected states (dB)			
	COM-1	COM-3	J2-J3	J3-J4	COM-1	COM-2	COM-3	COM-4
10	-98.77	-94.14	-97.99	-99.44	-73.36	-93.17	-93.33	-100.07
250	-94.84	-95.35	-95.25	-95.49	-59.61	-95.64	-98.51	-93.76
500	-95.65	-93.76	-94.98	-94.59	-54.49	-95.75	-96.24	-94.75
750	-96.55	-98.66	-96.03	-96.89	-51.13	-94.18	-98.07	-97.61
1000	-94.41	-98.39	-95.38	-99.29	-48.81	-93.29	-95.36	-95.82
1250	-97.83	-98.54	-92.86	-93.94	-47.20	-93.51	-94.19	-93.11
1500	-95.64	-93.53	-95.77	-95.14	-46.04	-95.28	-94.51	-97.04
1750	-95.67	-90.92	-94.44	-98.65	-45.00	-90.83	-94.47	-95.69
2000	-90.94	-94.36	-97.63	-93.53	-43.90	-94.23	-89.50	-94.76
2250	-93.40	-92.66	-92.87	-91.81	-42.63	-91.98	-86.80	-97.80
2500	-94.25	-89.77	-95.88	-90.34	-41.27	-92.93	-86.24	-95.44
2750	-91.17	-93.48	-98.80	-87.45	-40.07	-89.55	-84.85	-94.15
3000	-89.18	-94.10	-92.07	-88.64	-39.30	-87.99	-85.58	-94.81
3250	-88.00	-89.91	-97.48	-86.66	-38.93	-88.52	-94.22	-95.12
3500	-85.25	-87.31	-95.30	-85.79	-38.66	-89.10	-85.94	-96.52
3750	-84.02	-85.34	-95.78	-84.68	-38.18	-86.21	-76.98	-94.04
4000	-84.12	-83.30	-94.00	-83.10	-37.43	-83.25	-75.35	-98.44
4250	-80.50	-81.92	-92.87	-82.37	-36.53	-81.74	-74.11	-94.33
4500	-79.83	-79.74	-95.89	-80.94	-35.77	-82.67	-73.89	-92.00
4750	-77.63	-78.12	-91.07	-78.47	-35.45	-81.64	-74.86	-95.31
5000	-75.49	-75.66	-90.11	-75.55	-35.52	-83.44	-77.10	-92.34
5250	-73.21	-73.32	-94.39	-74.43	-35.60	-83.35	-84.05	-94.36
5500	-71.30	-71.62	-91.12	-72.97	-35.43	-82.13	-72.73	-94.85
5750	-69.75	-69.79	-94.12	-71.28	-34.98	-84.36	-69.05	-95.82
6000	-68.00	-67.73	-98.49	-69.52	-34.42	-88.16	-68.11	-94.63
6250	-65.83	-65.86	-94.84	-67.67	-34.03	-87.15	-67.70	-93.72
6500	-64.14	-64.25	-91.59	-65.72	-33.94	-81.51	-68.58	-93.63
6750	-62.99	-62.58	-88.65	-63.73	-33.93	-76.37	-70.59	-90.41
7000	-61.78	-61.74	-87.56	-62.06	-33.74	-72.98	-74.35	-89.27
7250	-61.23	-61.16	-87.69	-61.10	-33.27	-69.54	-68.01	-95.61
7500	-61.32	-61.18	-92.21	-60.64	-32.59	-67.17	-63.44	-95.45
7750	-61.65	-61.84	-92.36	-60.93	-31.65	-64.49	-61.60	-89.01
8000	-62.05	-62.12	-84.31	-60.79	-31.38	-63.12	-62.88	-93.90
8250	-61.93	-62.19	-82.75	-60.17	-30.29	-61.26	-62.57	-92.36
8500	-61.03	-61.35	-89.95	-59.84	-29.25	-59.67	-56.22	-86.37
8750	-59.67	-59.98	-88.14	-59.90	-29.35	-59.11	-56.42	-84.73
9000	-58.36	-58.70	-81.21	-58.91	-28.60	-57.66	-57.57	-89.14
9250	-57.25	-57.54	-74.34	-56.63	-27.76	-56.15	-53.27	-79.75
9500	-56.75	-56.76	-78.08	-55.50	-28.56	-56.36	-52.22	-79.74
9750	-56.05	-56.02	-82.07	-54.58	-28.60	-55.86	-52.62	-80.29
10000	-54.73	-54.80	-77.01	-52.75	-27.87	-54.44	-53.63	-77.15

SP4T Switch

U2C-1SP4T-852H

Typical Performance Data

Test Conditions: @ Temperature = +60°C, Pin = 8 dBm.

Freq. (MHz)	Insertion Loss (dB)			
	COM-J1	COM-J2	COM-J3	COM-J4
10	-2.20	-2.21	-2.21	-2.20
250	-2.45	-2.45	-2.45	-2.44
500	-2.58	-2.59	-2.59	-2.58
750	-2.72	-2.73	-2.72	-2.72
1000	-2.85	-2.85	-2.85	-2.84
1250	-2.93	-2.93	-2.93	-2.93
1500	-2.96	-2.97	-2.97	-2.96
1750	-2.97	-2.98	-2.97	-2.97
2000	-2.98	-3.00	-2.98	-2.99
2250	-3.02	-3.04	-3.02	-3.03
2500	-3.11	-3.14	-3.11	-3.12
2750	-3.22	-3.25	-3.22	-3.23
3000	-3.32	-3.35	-3.33	-3.33
3250	-3.39	-3.42	-3.40	-3.41
3500	-3.44	-3.48	-3.46	-3.47
3750	-3.52	-3.55	-3.52	-3.54
4000	-3.63	-3.66	-3.64	-3.65
4250	-3.76	-3.80	-3.78	-3.78
4500	-3.87	-3.91	-3.89	-3.90
4750	-3.92	-3.97	-3.95	-3.97
5000	-3.93	-3.98	-3.95	-3.99
5250	-3.95	-4.00	-3.96	-4.00
5500	-4.04	-4.08	-4.05	-4.06
5750	-4.20	-4.23	-4.19	-4.20
6000	-4.35	-4.37	-4.34	-4.34
6250	-4.43	-4.46	-4.43	-4.44
6500	-4.44	-4.48	-4.46	-4.46
6750	-4.46	-4.49	-4.48	-4.46
7000	-4.54	-4.55	-4.57	-4.51
7250	-4.69	-4.68	-4.70	-4.62
7500	-4.85	-4.83	-4.85	-4.78
7750	-5.06	-5.04	-5.05	-5.01
8000	-5.31	-5.24	-5.29	-5.21
8250	-5.63	-5.55	-5.60	-5.54
8500	-5.79	-5.76	-5.77	-5.75
8750	-6.02	-5.96	-5.98	-5.92
9000	-6.17	-6.13	-6.18	-6.10
9250	-6.36	-6.36	-6.31	-6.29
9500	-6.98	-6.95	-6.87	-6.82
9750	-7.17	-7.16	-7.21	-7.10
10000	-7.07	-7.12	-7.13	-7.07

NOTES:

- A. Performance and quality attributes and conditions not expressly stated in this specification document are intended to be excluded and do not form a part of this specification document.
- B. Electrical specifications and performance data contained in this specification document are based on Mini-Circuits' applicable established test performance criteria and measurement instructions.
- C. The parts covered by this specification document are subject to Mini-Circuits standard limited warranty and terms and conditions (collectively, "Standard Terms"); Purchasers of this part are entitled to the rights and benefits contained therein. For a full statement of the Standard Terms and the exclusive rights and remedies thereunder, please visit Mini-Circuits' website at <https://www.minicircuits.com/terms/viewterm.html>



SP4T Switch

U2C-1SP4T-852H

Typical Performance Data

Test Conditions: @ Temperature = +60°C, Pin = 8 dBm.

Freq. (MHz)	Return Loss, Active ports (dB)					R. Loss, Internally terminated ports (dB)			
	COM	J1	J2	J3	J4	J1	J2	J3	J4
10	-14.50	-14.51	-14.46	-14.46	-14.50	-23.03	-22.79	-22.93	-23.05
250	-15.58	-15.58	-15.48	-15.50	-15.55	-23.61	-23.31	-23.43	-23.65
500	-17.82	-17.58	-17.40	-17.52	-17.47	-23.71	-23.44	-23.66	-23.77
750	-21.98	-21.24	-20.86	-21.17	-20.82	-23.62	-23.32	-23.68	-23.64
1000	-27.12	-26.04	-25.48	-26.24	-25.61	-23.80	-23.36	-23.87	-23.67
1250	-23.81	-23.02	-22.96	-23.46	-23.53	-24.28	-23.49	-24.09	-23.81
1500	-19.91	-18.97	-18.88	-19.29	-19.33	-24.69	-23.71	-24.42	-24.13
1750	-18.21	-16.81	-16.64	-17.09	-17.01	-25.05	-23.95	-24.77	-24.43
2000	-18.34	-16.08	-15.84	-16.37	-16.23	-25.62	-24.32	-25.25	-24.98
2250	-20.17	-16.53	-16.22	-16.89	-16.62	-26.28	-24.91	-25.92	-25.62
2500	-24.31	-18.13	-17.72	-18.56	-18.03	-27.20	-25.55	-26.98	-26.54
2750	-31.67	-20.89	-20.42	-21.26	-20.58	-28.41	-26.35	-28.25	-27.53
3000	-30.69	-25.17	-24.93	-24.89	-24.51	-29.43	-27.24	-29.80	-28.75
3250	-27.39	-33.02	-34.30	-29.58	-31.07	-30.52	-27.92	-31.73	-29.84
3500	-27.99	-31.81	-32.35	-33.98	-34.14	-31.36	-28.69	-33.39	-30.78
3750	-33.22	-25.01	-24.58	-27.37	-26.08	-31.61	-28.85	-34.63	-30.99
4000	-37.01	-21.07	-21.09	-21.70	-21.99	-30.90	-29.12	-32.52	-31.68
4250	-27.93	-19.08	-19.24	-18.82	-19.56	-29.95	-28.77	-30.08	-31.10
4500	-24.88	-18.48	-18.66	-17.85	-18.54	-28.82	-28.15	-27.99	-30.55
4750	-24.39	-19.02	-19.23	-18.51	-18.49	-27.43	-27.47	-26.30	-29.89
5000	-24.60	-20.90	-20.90	-20.92	-19.61	-26.35	-26.75	-24.98	-28.92
5250	-22.67	-24.56	-23.72	-25.82	-22.70	-25.31	-26.09	-23.73	-27.19
5500	-19.80	-28.70	-27.62	-29.79	-28.19	-24.58	-25.26	-22.94	-26.66
5750	-18.12	-29.06	-30.17	-27.97	-40.24	-23.54	-24.54	-22.16	-25.44
6000	-18.12	-29.17	-32.78	-30.18	-32.67	-22.42	-23.53	-21.69	-24.32
6250	-20.56	-35.55	-36.42	-50.51	-28.77	-21.34	-22.67	-21.20	-23.51
6500	-26.71	-28.30	-25.70	-25.36	-25.42	-20.63	-21.87	-20.61	-22.48
6750	-23.30	-20.22	-19.73	-19.07	-21.05	-19.81	-21.20	-20.09	-21.73
7000	-17.51	-16.34	-16.65	-15.57	-17.71	-19.35	-20.93	-19.52	-21.27
7250	-14.93	-14.51	-15.24	-14.13	-16.22	-18.90	-20.55	-19.49	-20.88
7500	-14.34	-14.18	-15.22	-14.12	-15.86	-18.29	-20.05	-19.22	-20.60
7750	-17.17	-14.61	-16.36	-15.20	-17.02	-17.79	-19.90	-18.98	-20.22
8000	-14.69	-11.54	-12.97	-12.14	-13.45	-17.56	-19.88	-18.84	-20.57
8250	-12.91	-10.89	-12.32	-11.08	-11.90	-16.97	-19.46	-18.51	-20.35
8500	-13.97	-13.76	-15.92	-13.92	-15.15	-15.94	-18.56	-17.74	-19.70
8750	-12.33	-12.56	-14.69	-13.74	-15.74	-14.60	-16.88	-16.30	-18.03
9000	-13.82	-12.45	-14.00	-12.44	-14.50	-12.91	-14.73	-14.47	-15.88
9250	-14.38	-15.27	-17.45	-15.91	-19.45	-11.54	-12.77	-12.69	-13.72
9500	-9.58	-10.66	-11.30	-11.57	-12.77	-10.51	-11.12	-11.10	-12.11
9750	-11.58	-10.55	-10.36	-10.22	-11.31	-9.79	-9.92	-10.06	-10.82
10000	-22.43	-12.43	-11.28	-11.71	-12.62	-9.65	-9.18	-9.42	-10.20

NOTES:

- A. Performance and quality attributes and conditions not expressly stated in this specification document are intended to be excluded and do not form a part of this specification document.
- B. Electrical specifications and performance data contained in this specification document are based on Mini-Circuits' applicable established test performance criteria and measurement instructions.
- C. The parts covered by this specification document are subject to Mini-Circuits standard limited warranty and terms and conditions (collectively, "Standard Terms"); Purchasers of this part are entitled to the rights and benefits contained therein. For a full statement of the Standard Terms and the exclusive rights and remedies thereunder, please visit Mini-Circuits' website at <https://www.minicircuits.com/terms/viewterm.html>



SP4T Switch

U2C-1SP4T-852H

Typical Performance Data

Test Conditions: @ Temperature = +60°C, Pin = 8 dBm.

Freq. (MHz)	Isolation, Active states (dB)				Isolation, Disconnected states (dB)			
	COM-1	COM-3	J2-J3	J3-J4	COM-1	COM-2	COM-3	COM-4
10	-94.49	-100.71	-97.95	-96.29	-72.07	-98.18	-95.50	-97.71
250	-96.59	-93.96	-101.58	-94.51	-59.94	-98.84	-95.90	-96.27
500	-97.12	-94.26	-97.91	-99.38	-54.97	-95.16	-94.70	-95.63
750	-95.67	-95.60	-95.64	-95.86	-51.73	-96.87	-96.25	-100.47
1000	-97.43	-97.65	-94.77	-97.09	-49.44	-95.70	-97.96	-93.92
1250	-96.90	-93.51	-94.97	-93.53	-47.86	-93.78	-95.02	-97.32
1500	-93.64	-96.23	-96.47	-95.89	-46.68	-95.10	-94.07	-97.49
1750	-93.18	-92.73	-95.34	-98.13	-45.62	-93.33	-95.70	-94.39
2000	-91.73	-97.75	-96.92	-92.02	-44.50	-91.06	-90.56	-93.98
2250	-94.48	-96.43	-97.98	-92.93	-43.22	-91.51	-87.86	-93.74
2500	-93.06	-92.89	-94.03	-90.66	-41.85	-94.52	-87.89	-95.41
2750	-96.34	-96.20	-97.49	-89.28	-40.67	-90.88	-85.31	-98.06
3000	-90.40	-93.00	-91.36	-88.22	-39.90	-88.72	-85.55	-94.17
3250	-89.48	-91.33	-97.86	-89.31	-39.54	-88.59	-92.58	-93.83
3500	-85.09	-85.76	-92.92	-85.98	-39.26	-86.74	-87.80	-96.03
3750	-83.13	-84.41	-94.94	-82.82	-38.78	-87.12	-77.97	-95.43
4000	-84.18	-82.97	-93.38	-82.68	-38.01	-83.72	-75.83	-93.49
4250	-80.79	-80.73	-93.37	-82.29	-37.09	-83.16	-74.36	-98.15
4500	-79.04	-80.74	-96.04	-79.72	-36.33	-82.62	-74.48	-92.99
4750	-77.49	-77.85	-97.06	-78.30	-36.04	-82.25	-74.92	-92.03
5000	-76.63	-75.87	-89.71	-75.91	-36.13	-81.84	-77.57	-97.63
5250	-73.67	-73.86	-90.44	-74.92	-36.21	-82.40	-84.08	-94.70
5500	-72.07	-72.23	-93.94	-72.81	-36.03	-82.83	-73.88	-92.33
5750	-70.17	-70.22	-91.51	-71.66	-35.56	-86.06	-70.26	-92.37
6000	-68.48	-68.36	-93.62	-69.63	-35.01	-88.05	-68.80	-95.28
6250	-66.71	-66.67	-97.45	-67.75	-34.67	-91.22	-68.59	-91.29
6500	-65.21	-64.94	-91.35	-66.21	-34.59	-85.71	-69.25	-96.68
6750	-63.77	-63.58	-89.74	-64.42	-34.55	-78.73	-71.26	-98.29
7000	-62.61	-62.61	-87.70	-62.92	-34.31	-74.08	-73.97	-92.54
7250	-62.28	-62.10	-85.39	-61.89	-33.82	-70.89	-68.69	-96.47
7500	-62.31	-62.13	-89.71	-61.40	-33.15	-68.38	-64.18	-93.57
7750	-62.72	-62.71	-90.58	-61.42	-32.28	-65.35	-62.22	-90.02
8000	-62.46	-62.85	-84.32	-61.12	-31.90	-63.86	-63.52	-90.74
8250	-62.49	-62.69	-81.85	-60.53	-30.83	-61.77	-62.72	-93.19
8500	-61.42	-61.91	-91.87	-60.04	-29.86	-60.25	-56.90	-87.87
8750	-60.31	-60.36	-91.18	-60.10	-29.84	-59.64	-56.88	-87.02
9000	-58.96	-59.20	-82.70	-59.03	-29.19	-58.31	-58.17	-87.28
9250	-57.82	-58.03	-76.41	-57.14	-28.43	-56.85	-53.97	-81.97
9500	-57.29	-57.27	-80.32	-55.95	-29.20	-56.95	-53.11	-79.93
9750	-56.67	-56.70	-83.82	-55.15	-29.27	-56.60	-53.61	-81.41
10000	-55.30	-55.46	-78.09	-53.31	-28.44	-55.03	-54.71	-77.92

NOTES:

- A. Performance and quality attributes and conditions not expressly stated in this specification document are intended to be excluded and do not form a part of this specification document.
- B. Electrical specifications and performance data contained in this specification document are based on Mini-Circuits' applicable established test performance criteria and measurement instructions.
- C. The parts covered by this specification document are subject to Mini-Circuits standard limited warranty and terms and conditions (collectively, "Standard Terms"); Purchasers of this part are entitled to the rights and benefits contained therein. For a full statement of the Standard Terms and the exclusive rights and remedies thereunder, please visit Mini-Circuits' website at <https://www.minicircuits.com/terms/viewterm.html>



SP4T Switch

U2C-1SP4T-852H

Typical Performance Graphs

Test Conditions: @ Temperature = -10°C, Pin = 8 dBm.

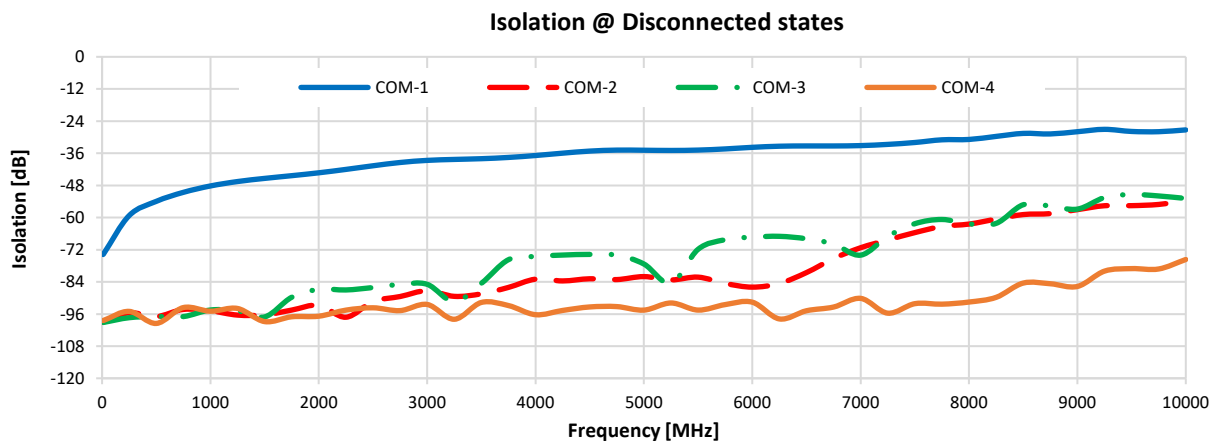
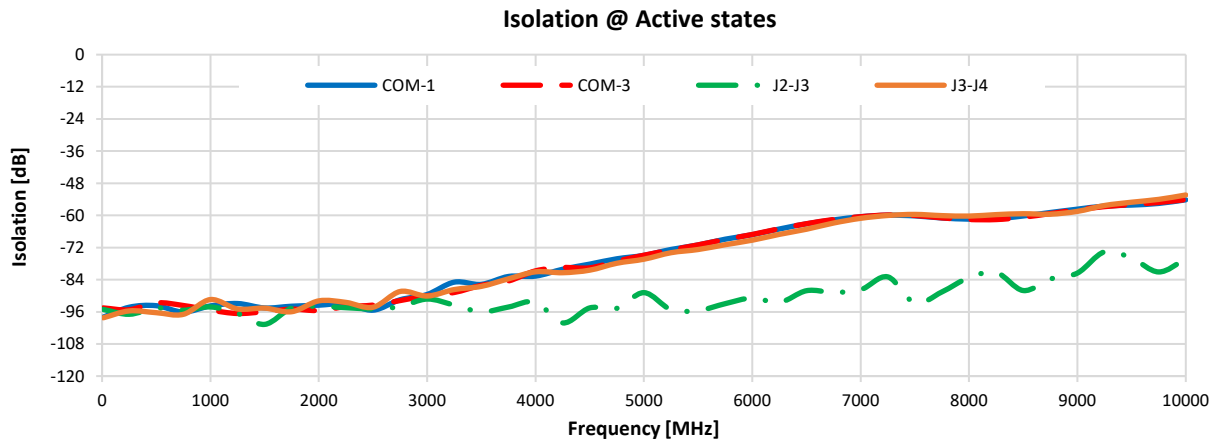
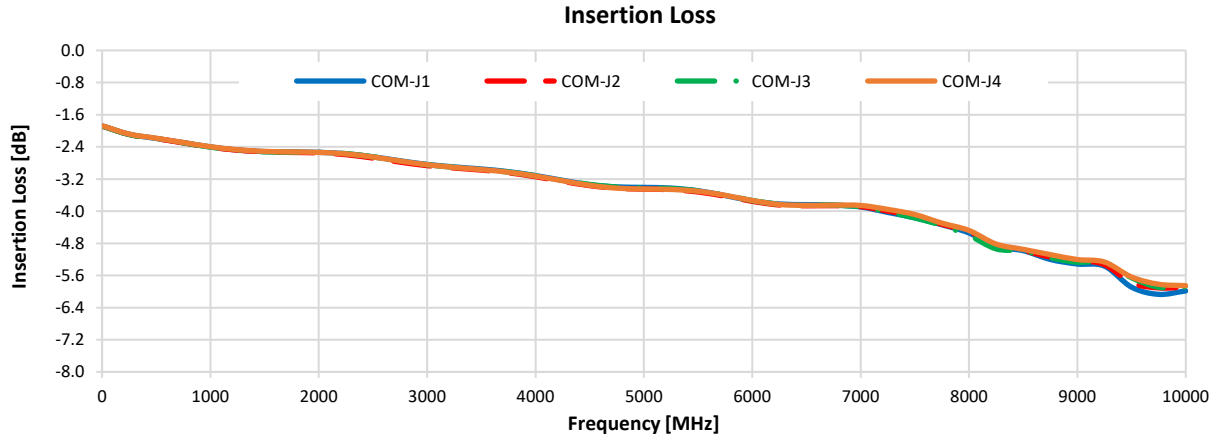

SP4T Switch

U2C-1SP4T-852H

Typical Performance Graphs

Test Conditions: @ Temperature = -10°C, Pin = 8 dBm.

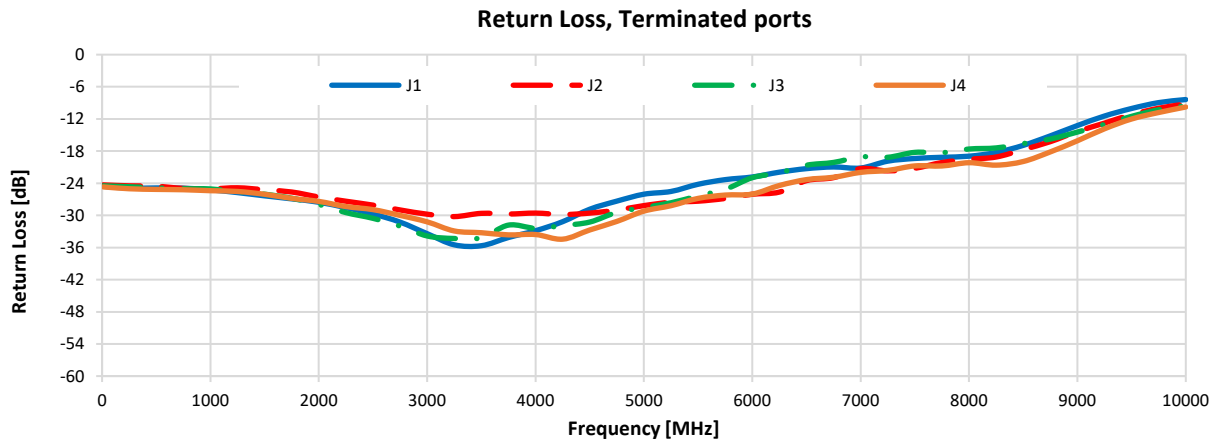
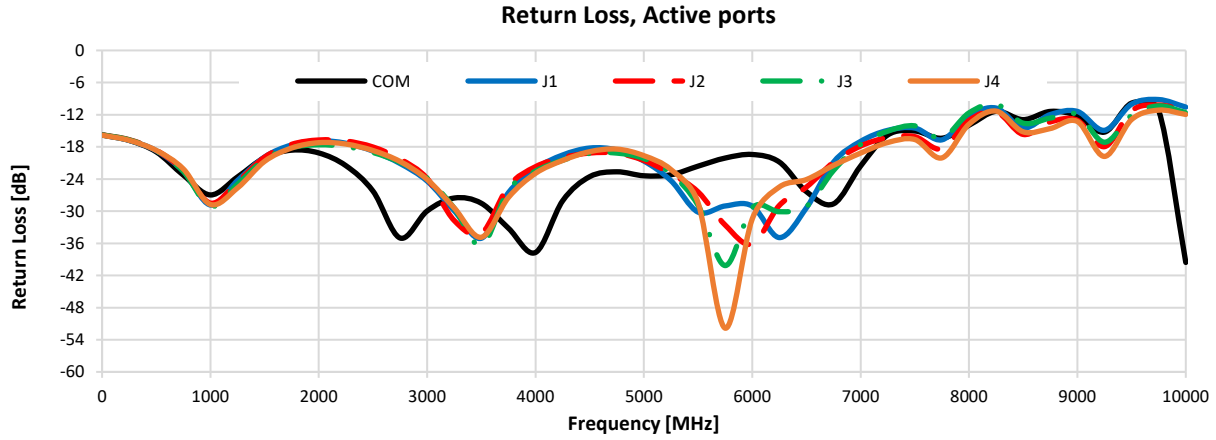

SP4T Switch

U2C-1SP4T-852H

Typical Performance Graphs

Test Conditions: @ Temperature = +25°C, Pin = 8 dBm.

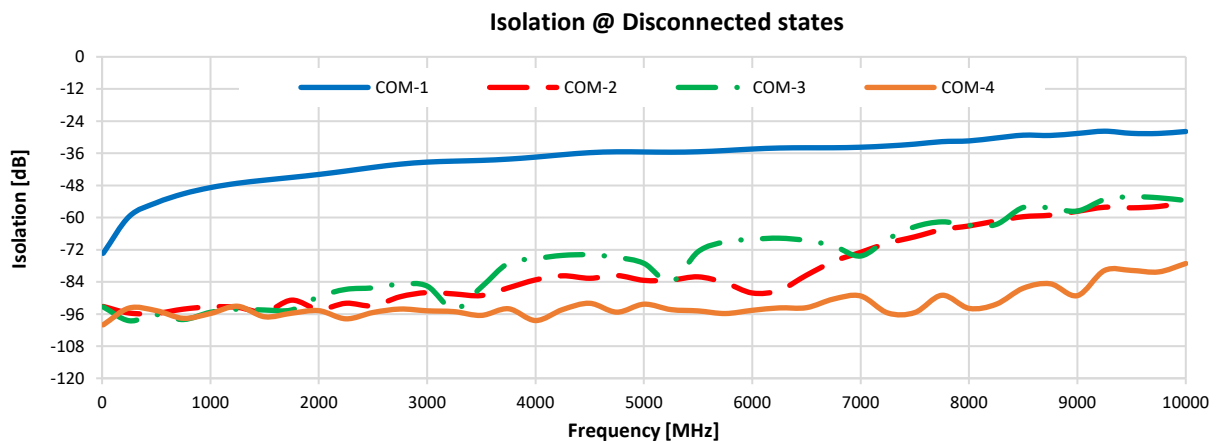
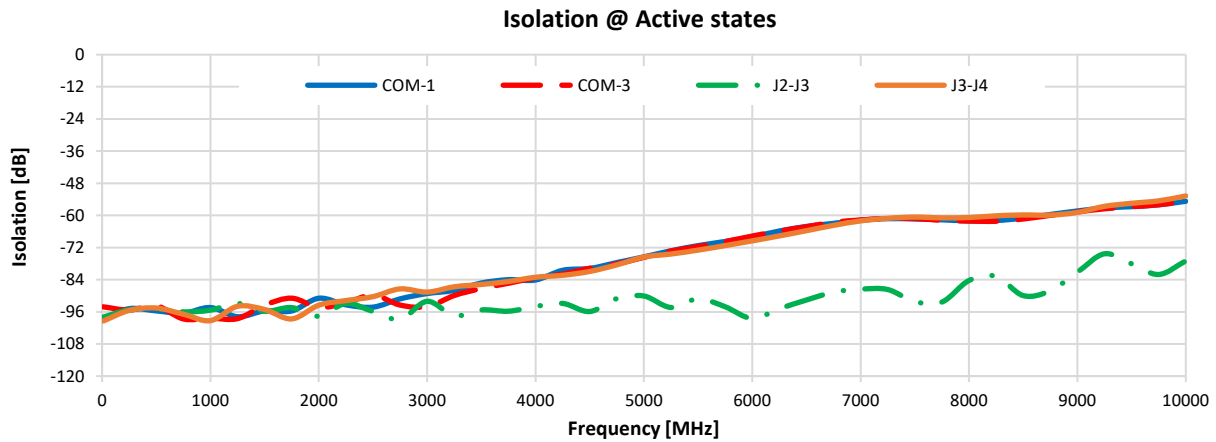
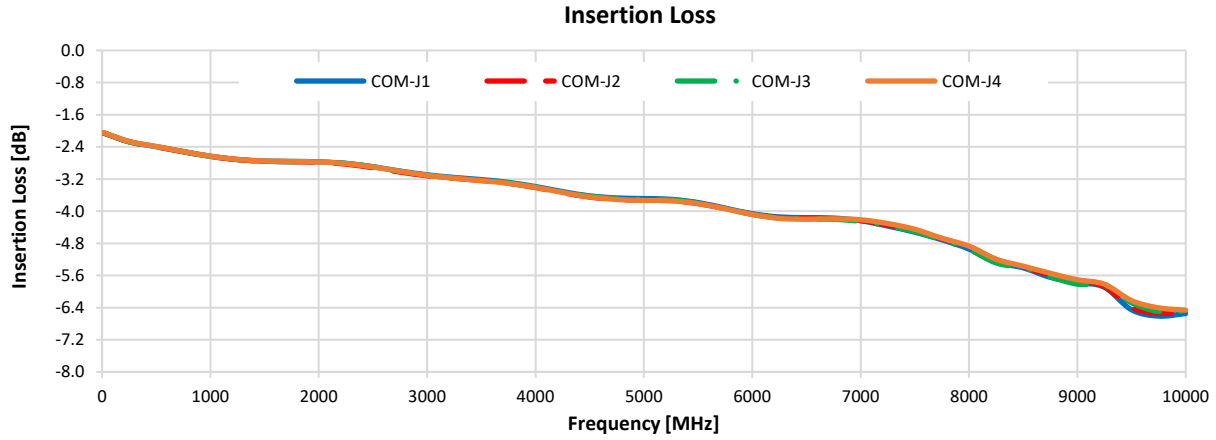

SP4T Switch

U2C-1SP4T-852H

Typical Performance Graphs

Test Conditions: @ Temperature = +25°C, Pin = 8 dBm.

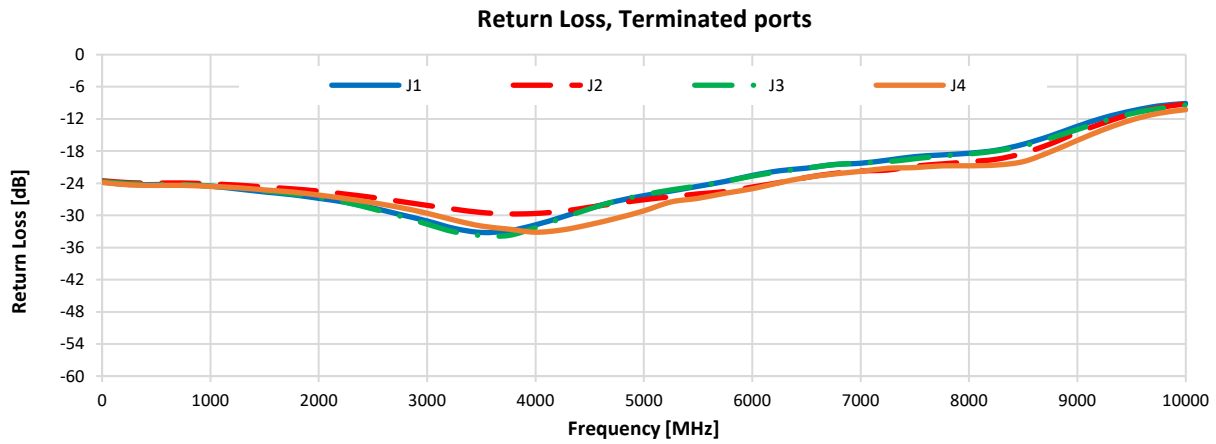
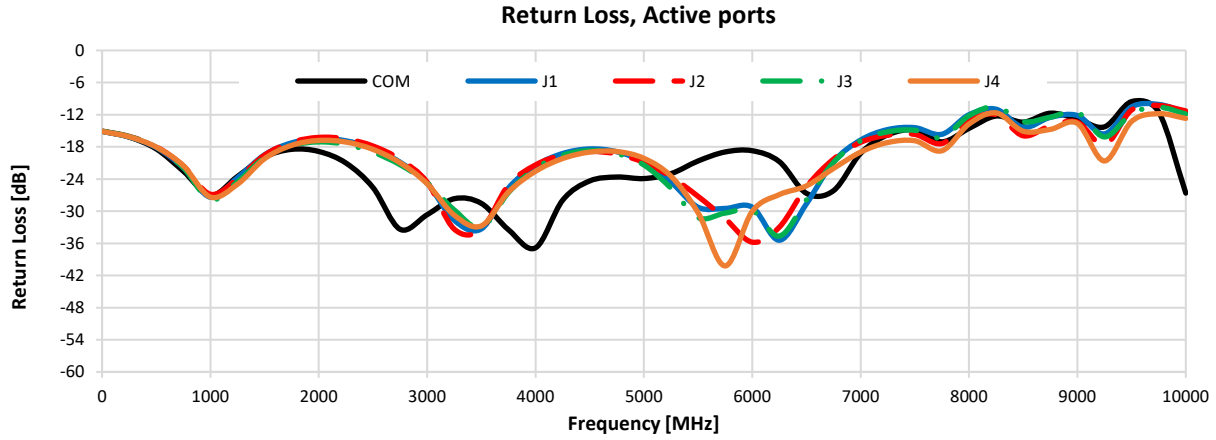

SP4T Switch

U2C-1SP4T-852H

Typical Performance Graphs

Test Conditions: @ Temperature = +60°C, Pin = 8 dBm.

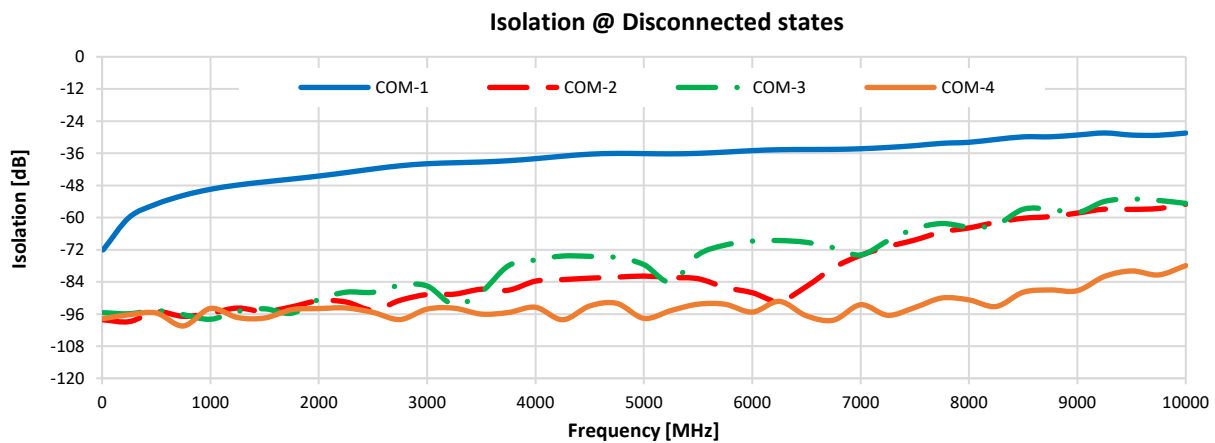
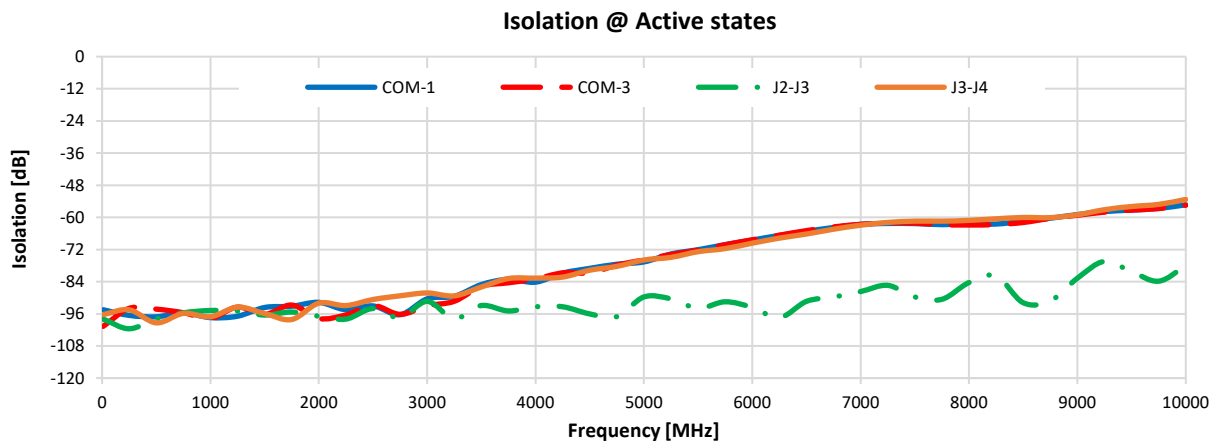
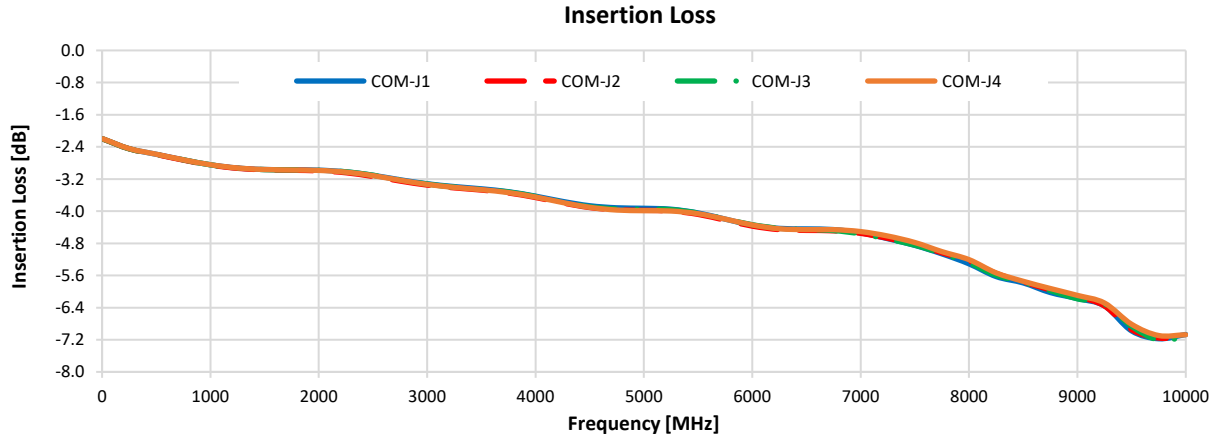

NOTES:

- A. Performance and quality attributes and conditions not expressly stated in this specification document are intended to be excluded and do not form a part of this specification document.
- B. Electrical specifications and performance data contained in this specification document are based on Mini-Circuit's applicable established test performance criteria and measurement instructions.
- C. The parts covered by this specification document are subject to Mini-Circuits standard limited warranty and terms and conditions (collectively, "Standard Terms"); Purchasers of this part are entitled to the rights and benefits contained therein. For a full statement of the Standard Terms and the exclusive rights and remedies thereunder, please visit Mini-Circuits' website at <https://www.minicircuits.com/terms/viewterm.html>



SP4T Switch

U2C-1SP4T-852H

Typical Performance Graphs

Test Conditions: @ Temperature = +60°C, Pin = 8 dBm.

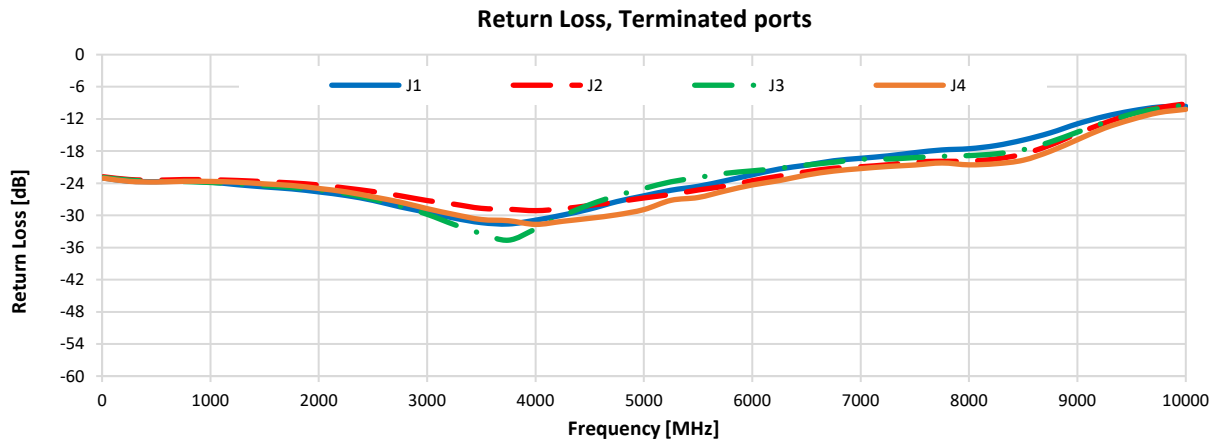
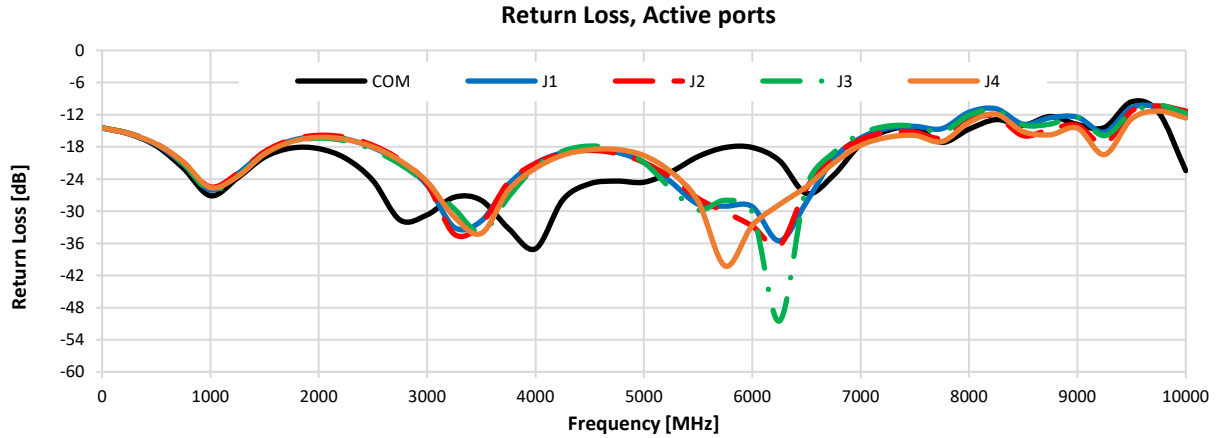

NOTES:

- A. Performance and quality attributes and conditions not expressly stated in this specification document are intended to be excluded and do not form a part of this specification document.
- B. Electrical specifications and performance data contained in this specification document are based on Mini-Circuits' applicable established test performance criteria and measurement instructions.
- C. The parts covered by this specification document are subject to Mini-Circuits standard limited warranty and terms and conditions (collectively, "Standard Terms"); Purchasers of this part are entitled to the rights and benefits contained therein. For a full statement of the Standard Terms and the exclusive rights and remedies thereunder, please visit Mini-Circuits' website at <https://www.minicircuits.com/terms/viewterm.html>



Case Style

RB

Outline Dimensions

RB2502

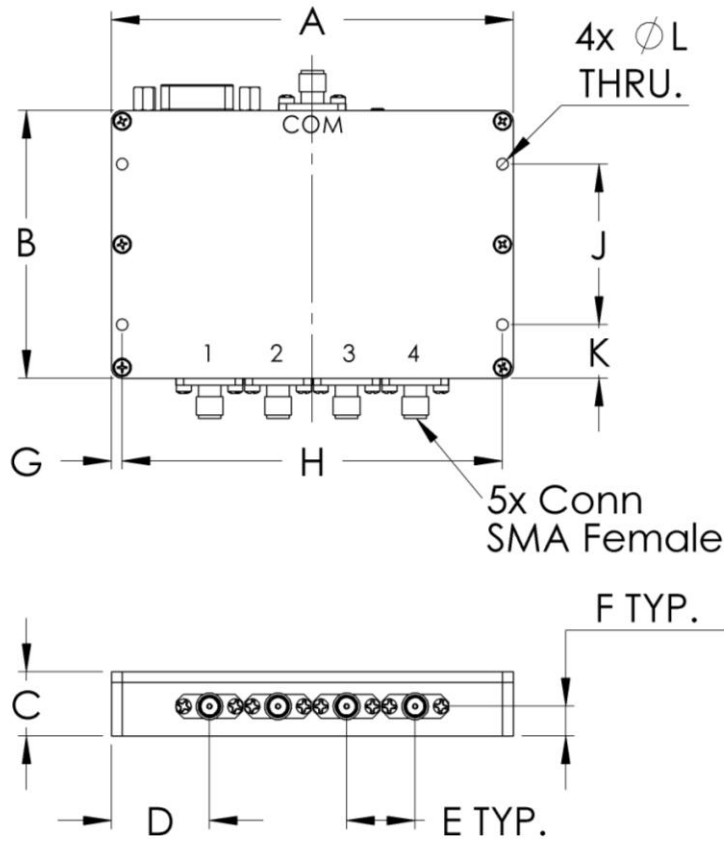
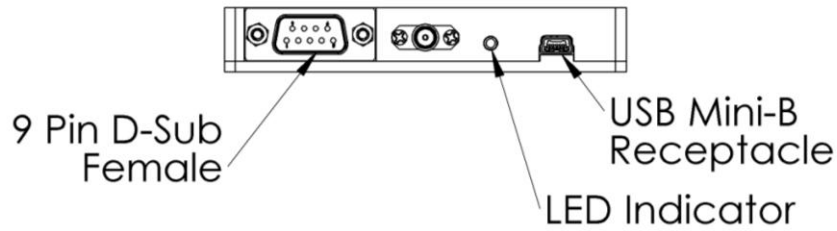

CASE#	A	B	C	D	E	F	G	H	J	K	L	WT. GRAMS
RB2502	3.75 (95.25)	2.50 (63.50)	.60 (15.24)	.915 (23.24)	.640 (16.26)	.278 (7.06)	.10 (2.54)	3.550 (90.17)	1.500 (38.10)	.50 (12.70)	.106 (2.69)	220

Dimensions are in inches (mm). Tolerances: 2PL. +/- .03; 3PL. +/- .015

Notes:

1. Case material: Aluminum alloy.
2. Case finish: Nickel Plate.

Mini-Circuits[®]

INTERNET <http://www.minicircuits.com>

P.O. Box 350166, Brooklyn, New York 11235-0003 (718) 934-4500 Fax (718) 332-4661

Distribution Centers NORTH AMERICA 800-654-7949 • 417-335-5935 • Fax 417-335-5945 • EUROPE 44-1252-832600 • Fax 44-1252-837010

Mini-Circuits ISO 9001 & ISO 14001 Certified

Environmental Specifications **ENV55T2**



All Mini-Circuits products are manufactured under exacting quality assurance and control standards, and are capable of meeting published specifications after being subjected to any or all of the following physical and environmental test.

Specification	Test/Inspection Condition	Reference/Spec
Operating Temperature	-10° to 60° C Ambient Environment	Individual Model Data Sheet
Storage Temperature	-20° to 85° C Ambient Environment	Individual Model Data Sheet
Operating and Storage Humidity	5% to 85% RH (non-condensing)	Ambient
Bench Handling Test	Bench Top Tip 45° & Drop	MIL-PRF-28800F
Transit Drop Test	Free Fall Drop, 20 cm (7.9 inches)	MIL-PRF-28800F Class 3