

**THE BIG DEAL**

- Wideband: 0.5-5 GHz
- Built-in Bypass switching
- Low Noise figure: 1.5 dB typ. at 2.0 GHz
- High Gain: 18.4 dB typ. at 2 GHz
- Ultra Flat Gain: 0.7 dB from 0.7 to 2.1 GHz
- P1dB: +15.1 dBm typ. at 2.0 GHz
- Minimal matching components
- Specified over full band operation

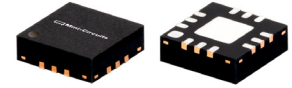

Generic photo used for illustration purposes only

CASE STYLE: DQ1225

+RoHS Compliant

The +Suffix identifies RoHS Compliance. See our web site for RoHS Compliance methodologies and qualifications

APPLICATIONS

- Wireless Base Station Systems
- Test and Measurement Systems
- Multi-Band Receivers

PRODUCT OVERVIEW

Mini-Circuits TSS-53LNB3+ is a low-noise amplifier offering industry-leading performance over its full frequency range from 500 MHz to 5 GHz. It contains internal switching, allowing the user control of the amplifier to handle both high and low signal levels by bypassing the LNA in the presence of large signals. The TSS-53LNB3+ utilizes E-PHEMT technology to achieve excellent noise figure performance in a unique cascade configuration enabling the combination of very wide band performance and flat gain. This model comes in a tiny, 3 x 3mm, 12-lead MCLP package.

KEY FEATURES

Feature	Advantages
Ultra-wideband: 500 MHz – 5 GHz	Ideal for a wide range of receiver applications including military, commercial wireless, and instrumentation.
Very flat gain	Ideal for broadband or multi-band applications. Just one, cost-efficient model required for multiple frequency usage.
Minimal external matching components required. 15 dB return loss typ.	Minimizes the need for external matching networks, simplifying circuit designs, and enabling the amplifier to operate over multiple bands in a single application circuit.
Internal bypass switch feature	Unique design handles low to high signal levels with minimal noise distortion.
Built-in DC blocking cap at RF-Out port & separate pads for RF-Out & Vdd	Simplifies biasing eliminates need for Bias-Tee at output.
Compact size: 3 x 3 x 0.9 mm	Saves space in dense system layouts. Low inductance, repeatable transitions, and excellent thermal contact.

**WIDEBAND**

Low Noise Bypass Amplifier **TSS-53LNB3+**

Mini-Circuits

ELECTRICAL SPECIFICATIONS¹ AT 25°C, Z₀=50Ω AND V_{DD}=3V, UNLESS OTHERWISE NOTED

Parameter	Condition (GHz)	Amplifier-ON			Amplifier-Bypass	Units
		Min.	Typ.	Max.	Typ.	
Frequency Range		0.5		5.0		GHz
Noise Figure	0.5		1.3		—	dB
	1.0		1.3		—	
	2.0		1.5		—	
	3.0		1.6		—	
	4.0		1.7		—	
	5.0		1.8		—	
Gain	0.5	—	19.5	—	-0.8	dB
	1.0	—	19.3	—	-0.8	
	2.0	16.5	18.4	20.2	-1.1	
	3.0	—	17.2	—	-1.3	
	4.0	—	16.1	—	-1.6	
	5.0	—	14.8	—	-1.7	
Gain Flatness	0.7 - 2.1		±0.7		±0.2	dB
Input Return Loss	0.5	—	16.6		24.3	dB
	1.0	—	16.6		19.0	
	2.0	—	12.4		13.4	
	3.0	—	9.8		12.5	
	4.0	—	10.1		10.6	
	5.0	—	11.3		11.3	
Output Return Loss	0.5		18.5		24.1	dB
	1.0		18.3		17.7	
	2.0		18.8		13.2	
	3.0		12.9		13.5	
	4.0		10.2		11.5	
	5.0		6.5		10.6	
Output Power @1dB compression AMP-ON ² Input Power @1dB compression AMP-Bypass ²	0.5		13.6		28	dBm
	1.0		14.8		—	
	2.0		14.9		29	
	3.0		14.7		—	
	4.0		14.7		—	
	5.0		13.9		29	
Output IP3	0.5		25.2		28.7	dBm
	1.0		24.5		20.7	
	2.0		24.8		26.6	
	3.0		23.6		28.3	
	4.0		23.8		29.2	
	5.0		20.7		30.1	
Device Operating Voltage (V _{DD})		2.7	3	3.3	3	V
Device Operating Current (I _D)			42		2	mA
Enable Voltage (V _E)			3		0	V
Enable Control Current (I _E)			2.0		0	mA
DC Current (I _D) Variation Vs. Temperature ³			-19		—	μA/°C
DC Current (I _D) Variation Vs. Voltage			0.008		—	mA/mV
Thermal Resistance, junction-to-ground lead			60		—	°C/W

1. Measured on Mini-Circuits Characterization test board TB-780+. See Characterization Test Circuit (Fig. 1)

2. Current increases at P1dB

3. (Current at 85°C - Current at -45°C)/130



WIDEBAND

Low Noise Bypass Amplifier TSS-53LNB3+

Mini-Circuits

MAXIMUM RATINGS⁴

Parameter	Ratings
Operating Temperature (ground lead)	-40°C to 85°C
Storage Temperature	-65°C to 150°C
Total Power Dissipation	0.7 W
Input Power	Amplifier-ON: 8 dBm (continuous), 19 dBm (5 min max.) Amplifier Bypass: 16 dBm (continuous), 29 dBm (5 min max.)
DC Voltage Vdd	7.0 V
DC Voltage Enable	7.0 V
Max. Voltage on pad 8	15 V

CONTROL VOLTAGE (V_E) FIG. 1

	Min.	Typ.	Max.	Units
Amplifier-ON	2.7	3.0	3.3	V
Amplifier-Bypass	0	—	0.5	V

5. Permanent damage may occur if any of these limits are exceeded. Electrical maximum ratings are not intended for continuous normal operation.

SWITCHING SPECIFICATIONS (RISE/FALL TIME)

Parameter		Min.	Typ.	Max.	Units
Amplifier ON to Bypass	OFF TIME (50% Control to 10% RF)	—	55*	—	ns
	FALL TIME (90 to 10% RF)	—	34	—	
Amplifier Bypass to ON	ON TIME (50% Control to 90% RF)	—	960*	—	ns
	RISE TIME (10% to 90% RF)	—	240	—	
Control Voltage Leakage		—	65	—	mV

* Measured with ±25nS uncertainty

SIMPLIFIED SCHEMATIC AND BONDING PAD DESCRIPTION

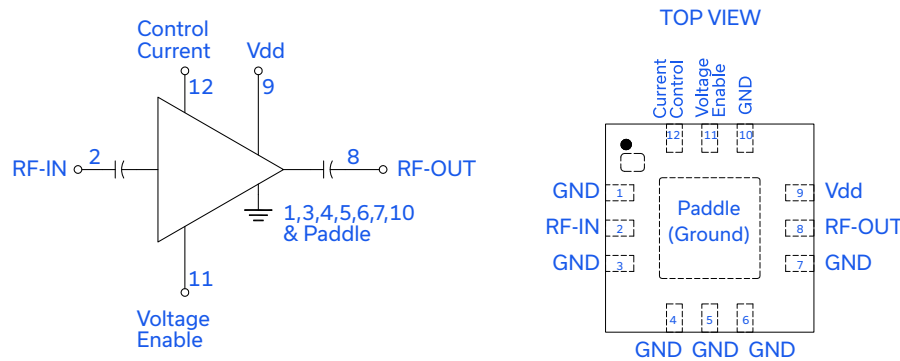

Function	Pad Number	Description (See Figure 2)
RF-IN	2	RF-Input pad. Connect to Ground Via L1. Add a DC blocking cap in series of appropriate value if required.
RF-OUT	8	RF-Output pad. No external DC blocking cap required.
Current Control	12	Control Current pad, voltage level on this pad sets the I _{dd} . Connect to pad 11 via 3.92 kΩ resistor.
Voltage Enable	11	Voltage Enable Pad. Voltage level on this pad determines Amplifier is ON or bypassed.
Vdd	9	Supply Voltage Pad. Connect to Vdd via L2.
Ground	1,3,4,5,6,7,10 & Paddle	Connect to ground. Use via holes as shown in "Suggested Layout for PCB Design" to reduce ground path inductance for best performance.





WIDEBAND

Low Noise Bypass Amplifier **TSS-53LNB3+**

CHARACTERIZATION TEST CIRCUIT

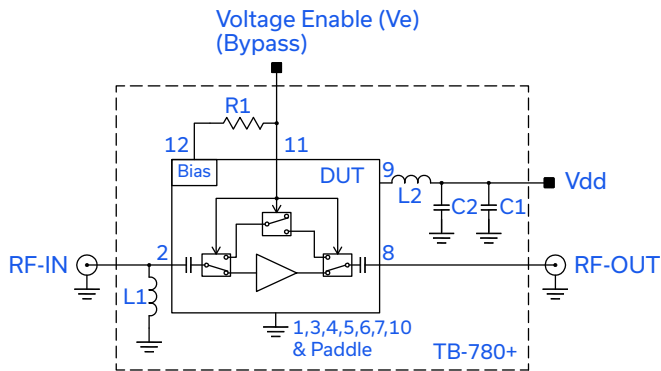

Component	Size	Value	Units
L1	0402	47	nH
L2	0402	56	nH
C1	0402	0.1	μ F
C2	0402	10	pF
R1	0402	3.92	K Ω

Fig 1. Block diagram of Test Circuit used for characterization. (DUT soldered on Mini-Circuits Characterization test board TB-780+)
Gain, Return loss, Output power at 1dB compression (P1 dB), output IP3 (OIP3) and noise figure measured using Agilent's N5242A PNA-X microwave network analyzer.

Conditions:

1. Gain and Return loss: Pin= -25dBm
2. Output IP3 (OIP3): Two tones, spaced 1 MHz apart, 0 dBm/tone at output.
3. Switching Time: Pin=-25 dBm at 500 MHz. Venable=3V at 10 kHz. Vd=3V.

RECOMMENDED APPLICATION CIRCUIT

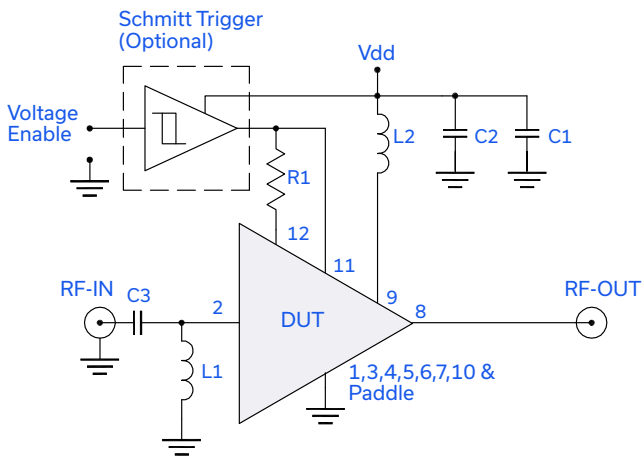

Component	Size	Value	Units
L1	0402	47	nH
L2	0402	56	nH
R1	0402	3.92	k Ω
C1	0402	0.1	μ F
C2	0402	10	pF
C3	0402	1000	pF
Schmitt Trigger	SN74LVC2G17DCKR Texas Instruments		—

Fig 2. Recommended Application Circuit.

PRODUCT MARKING



Marking may contain other features or characters for internal lot control





WIDEBAND

Low Noise Bypass Amplifier TSS-53LNB3+

Mini-Circuits

ADDITIONAL DETAILED TECHNICAL INFORMATION IS AVAILABLE ON OUR DASH BOARD. TO ACCESS [CLICK HERE](#)

Performance Data	Data Table Swept Graphs S-Parameter (S2P Files) Data Set (.zip file)
Case Style	DQ1225 Plastic package, exposed paddle lead finish: Matte-Tin
Tape & Reel Standard quantities available on reel	F66 7" reels with 20, 50, 100, 200, 500, 1K, or 2K devices
Suggested Layout for PCB Design	PL-421
Evaluation Board	TB-779+
Environmental Ratings	ENV12

ESD RATING

Human Body Model (HBM): Class 1A (250 to <500V) in accordance with ANSI/ESD STM 5.1 - 2001

Machine Model (MM): Class M1 (pass 50V) in accordance with ANSI/ESD STM5.2-1999

MSL RATING

Moisture Sensitivity: MSL1 in accordance with IPC/JEDEC J-STD-020D

MSL FLOW CHART

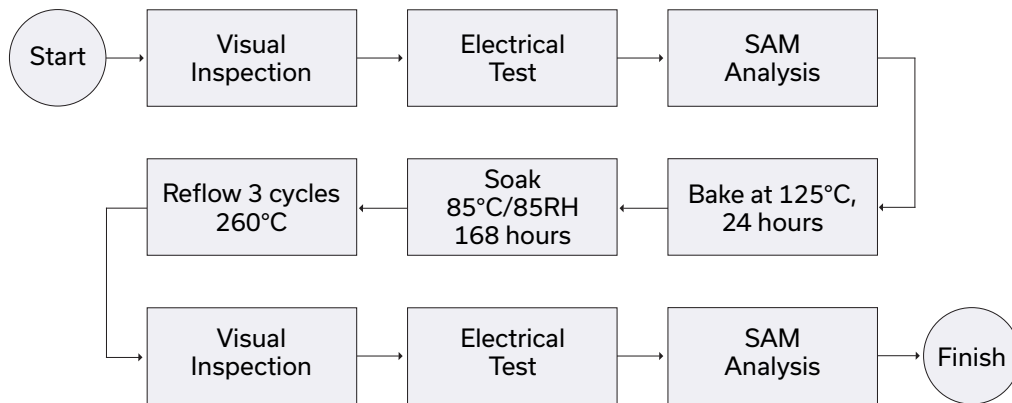

- NOTES**
- A. Performance and quality attributes and conditions not expressly stated in this specification document are intended to be excluded and do not form a part of this specification document.
 - B. Electrical specifications and performance data contained in this specification document are based on Mini-Circuit's applicable established test performance criteria and measurement instructions.
 - C. The parts covered by this specification document are subject to Mini-Circuits standard limited warranty and terms and conditions (collectively, "Standard Terms"); Purchasers of this part are entitled to the rights and benefits contained therein. For a full statement of the standard. Terms and the exclusive rights and remedies thereunder, please visit Mini-Circuits' website at www.minicircuits.com/MCLStore/terms.jsp



Typical Performance Data

NOTE: Use PDF Bookmarks to view DATA at required conditions

Definitions:

Input Return Loss = -S11 (dB)

Gain(Power Gain) = S21 (dB)

Reverse Isolation = -S12 (dB)

Output Return Loss = -S22 (dB)

TEST CONDITIONS: Vd = Ve = 3.00V, Id = 40.31mA @ Temperature = +25°C

FREQ	Gain	Isolation	Input Return Loss	Output Return Loss	Stability		IP-3 Output	1dB Comp. Output	Noise Figure
					K	Measure			
(MHz)	(dB)	(dB)	(dB)	(dB)	K	Measure	(dBm)	(dBm)	(dB)
100	10.54	33.97	1.59	3.22	1.68	0.82	21.81	8.21	5.24
200	17.99	26.08	6.77	11.36	1.20	0.91	24.06	10.42	1.95
300	19.23	24.63	11.96	17.27	1.13	0.75	24.91	11.87	1.54
400	19.55	24.19	15.38	18.68	1.11	0.67	25.55	12.85	1.32
500	19.65	24.01	17.00	18.50	1.10	0.64	25.22	13.62	1.29
600	19.66	23.93	17.59	18.16	1.09	0.63	25.29	14.04	1.38
700	19.64	23.89	17.53	18.07	1.09	0.63	25.09	14.34	1.28
800	19.60	23.87	17.38	18.02	1.09	0.63	25.44	14.53	1.29
900	19.55	23.86	16.96	18.19	1.09	0.64	25.84	14.60	1.21
1000	19.48	23.87	16.56	18.32	1.10	0.65	24.59	14.78	1.30
1200	19.33	23.91	15.76	18.78	1.10	0.67	25.43	14.84	1.35
1400	19.15	23.96	15.04	19.27	1.11	0.70	25.44	14.92	1.42
1600	18.95	24.02	14.32	19.57	1.12	0.73	25.08	14.94	1.48
2000	18.53	24.18	12.93	18.83	1.13	0.79	24.91	14.87	1.44
2200	18.29	24.25	12.30	17.70	1.14	0.82	23.86	14.89	1.49
2600	17.84	24.41	11.38	15.14	1.16	0.85	24.24	14.73	1.58
2800	17.61	24.50	11.07	13.98	1.18	0.86	24.04	14.59	1.60
3000	17.39	24.57	10.84	12.96	1.19	0.86	23.63	14.74	1.56
3200	17.19	24.64	10.71	12.13	1.20	0.86	23.23	14.50	1.60
3400	16.99	24.71	10.73	11.46	1.22	0.85	24.22	14.44	1.56
3600	16.82	24.79	10.80	10.89	1.24	0.85	23.95	14.55	1.65
3800	16.64	24.84	11.02	10.49	1.25	0.85	24.45	14.74	1.60
4000	16.48	24.89	11.40	10.18	1.27	0.84	24.11	14.74	1.66
4200	16.34	24.95	11.79	9.85	1.29	0.84	23.16	14.70	1.66
4400	16.19	25.00	12.26	9.59	1.31	0.83	22.89	14.58	1.70
4600	16.02	25.08	12.65	9.42	1.33	0.83	23.58	14.40	1.72
4800	15.83	25.23	12.66	9.18	1.35	0.84	23.42	14.40	1.77
5000	15.61	25.42	12.29	8.97	1.37	0.86	23.89	14.36	1.77
5200	15.35	25.61	11.58	8.82	1.40	0.88	23.33	14.21	1.98
5400	15.01	25.93	10.48	8.61	1.44	0.91	21.94	13.57	2.08
5600	14.57	26.33	9.11	8.51	1.48	0.95	21.50	12.22	2.24
5800	14.18	26.76	7.89	8.29	1.51	0.99	22.15	12.10	2.40
6000	13.60	27.31	6.70	7.96	1.57	1.03	21.96	12.17	2.59

Typical Performance Data

Definitions:

Input Return Loss = -S11 (dB)

Gain(Power Gain) = S21 (dB)

Reverse Isolation = -S12 (dB)

Output Return Loss = -S22 (dB)

TEST CONDITIONS: Vd = 2.75V, Ve = 3V, Id = 38.75mA @ Temperature = +25°C

FREQ	Gain	Isolation	Input Return Loss	Output Return Loss	Stability		IP-3 Output	1dB Comp. Output	Noise Figure
					K	Measure			
(MHz)	(dB)	(dB)	(dB)	(dB)	K	Measure	(dBm)	(dBm)	(dB)
100	10.28	33.82	1.59	3.23	1.69	0.82	18.13	6.53	5.33
200	17.68	25.96	6.57	11.34	1.20	0.93	22.43	8.72	1.96
300	18.95	24.47	11.47	17.41	1.13	0.76	23.92	10.15	1.57
400	19.28	24.01	14.66	19.14	1.11	0.69	24.63	11.13	1.34
500	19.38	23.82	16.26	19.07	1.10	0.66	24.53	11.90	1.30
600	19.40	23.73	16.87	18.75	1.10	0.64	24.60	12.33	1.42
700	19.38	23.69	16.85	18.64	1.09	0.64	24.43	12.62	1.32
800	19.34	23.67	16.72	18.58	1.09	0.64	24.77	12.81	1.30
900	19.28	23.66	16.29	18.77	1.09	0.65	25.13	12.95	1.23
1000	19.22	23.67	15.89	18.87	1.09	0.66	24.07	13.10	1.29
1200	19.05	23.71	15.05	19.25	1.10	0.69	24.82	13.19	1.39
1400	18.86	23.77	14.27	19.61	1.11	0.72	24.77	13.27	1.41
1600	18.65	23.84	13.53	19.65	1.11	0.75	24.47	13.25	1.47
2000	18.20	24.01	12.14	18.34	1.13	0.81	24.35	13.21	1.47
2200	17.95	24.09	11.55	17.10	1.14	0.84	23.32	13.18	1.52
2600	17.47	24.25	10.67	14.55	1.16	0.87	23.65	13.03	1.61
2800	17.23	24.35	10.40	13.44	1.17	0.88	23.47	12.94	1.64
3000	17.00	24.43	10.21	12.47	1.19	0.88	23.08	12.94	1.60
3200	16.79	24.49	10.09	11.69	1.20	0.88	22.68	12.82	1.64
3400	16.59	24.56	10.14	11.05	1.22	0.87	23.62	12.74	1.61
3600	16.42	24.64	10.23	10.50	1.23	0.87	23.36	12.75	1.69
3800	16.24	24.69	10.43	10.12	1.25	0.86	23.82	12.86	1.62
4000	16.07	24.73	10.77	9.83	1.27	0.85	23.53	12.84	1.68
4200	15.92	24.79	11.13	9.52	1.29	0.85	22.60	12.80	1.70
4400	15.76	24.85	11.54	9.27	1.30	0.85	22.36	12.67	1.73
4600	15.59	24.93	11.83	9.10	1.33	0.85	22.97	12.52	1.77
4800	15.38	25.08	11.76	8.86	1.35	0.86	22.81	12.42	1.83
5000	15.14	25.28	11.37	8.65	1.37	0.87	23.31	12.36	1.84
5200	14.86	25.49	10.65	8.49	1.40	0.90	22.69	12.19	2.03
5400	14.49	25.82	9.65	8.28	1.43	0.92	21.36	11.52	2.14
5600	14.02	26.24	8.40	8.18	1.48	0.97	20.80	10.46	2.30
5800	13.59	26.68	7.30	7.94	1.52	1.01	21.34	10.36	2.48
6000	12.98	27.25	6.21	7.62	1.57	1.05	21.17	10.29	2.69

Typical Performance Data

Definitions:

Input Return Loss = -S11 (dB)

Gain(Power Gain) = S21 (dB)

Reverse Isolation = -S12 (dB)

Output Return Loss = -S22 (dB)

TEST CONDITIONS: Vd = 3.25V, Ve = 3V, Id = 41.78mA @ Temperature = +25°C

FREQ	Gain	Isolation	Input Return Loss	Output Return Loss	Stability		IP-3 Output	1dB Comp. Output	Noise Figure
					K	Measure			
(MHz)	(dB)	(dB)	(dB)	(dB)	K	Measure	(dBm)	(dBm)	(dB)
100	10.72	34.15	1.60	3.31	1.70	0.84	23.10	9.53	5.19
200	18.21	26.23	6.92	11.56	1.20	0.91	24.74	11.76	1.91
300	19.44	24.81	12.36	17.44	1.13	0.74	25.53	13.22	1.49
400	19.74	24.39	15.95	18.65	1.11	0.67	26.20	14.25	1.30
500	19.84	24.22	17.63	18.39	1.10	0.64	25.81	15.02	1.27
600	19.85	24.14	18.14	18.03	1.10	0.63	25.78	15.39	1.41
700	19.83	24.10	18.07	17.92	1.10	0.63	25.59	15.64	1.29
800	19.79	24.09	17.94	17.88	1.10	0.63	25.93	15.82	1.28
900	19.74	24.08	17.52	18.05	1.10	0.63	26.38	15.82	1.21
1000	19.68	24.08	17.19	18.19	1.10	0.64	25.05	16.00	1.28
1200	19.53	24.12	16.45	18.69	1.11	0.67	25.89	16.03	1.34
1400	19.37	24.16	15.79	19.28	1.11	0.69	25.86	16.09	1.42
1600	19.19	24.22	15.16	19.74	1.12	0.72	25.47	16.13	1.45
2000	18.79	24.35	13.75	19.38	1.14	0.78	25.31	16.06	1.42
2200	18.57	24.42	13.10	18.33	1.15	0.80	24.23	16.11	1.49
2600	18.13	24.57	12.09	15.72	1.17	0.83	24.63	15.94	1.56
2800	17.92	24.66	11.73	14.50	1.19	0.84	24.44	15.78	1.61
3000	17.70	24.74	11.46	13.44	1.20	0.84	24.01	16.00	1.52
3200	17.51	24.80	11.28	12.57	1.21	0.84	23.65	15.59	1.58
3400	17.32	24.87	11.29	11.88	1.23	0.84	24.72	15.54	1.57
3600	17.15	24.96	11.34	11.28	1.25	0.84	24.37	15.76	1.66
3800	16.98	25.01	11.53	10.87	1.26	0.83	24.78	16.06	1.58
4000	16.82	25.06	11.93	10.56	1.28	0.83	24.44	16.13	1.63
4200	16.68	25.12	12.36	10.23	1.30	0.83	23.42	16.07	1.63
4400	16.54	25.17	12.91	9.96	1.32	0.82	23.20	15.97	1.69
4600	16.38	25.24	13.42	9.80	1.34	0.82	23.85	15.68	1.70
4800	16.21	25.39	13.52	9.55	1.36	0.83	23.60	15.80	1.75
5000	16.01	25.57	13.26	9.33	1.39	0.84	24.07	15.80	1.77
5200	15.77	25.75	12.55	9.19	1.41	0.86	23.50	15.64	1.95
5400	15.45	26.05	11.38	8.99	1.45	0.89	22.16	15.01	2.01
5600	15.04	26.44	9.87	8.89	1.49	0.94	21.72	13.56	2.18
5800	14.68	26.84	8.53	8.68	1.53	0.98	22.31	13.32	2.36
6000	14.13	27.38	7.21	8.36	1.58	1.02	22.07	13.50	2.53

Typical Performance Data

Definitions:

Input Return Loss = -S11 (dB)

Gain(Power Gain) = S21 (dB)

Reverse Isolation = -S12 (dB)

Output Return Loss = -S22 (dB)

TEST CONDITIONS: Vd = Ve = 3.00V, Id = 43.24mA @ Temperature = -45°C

FREQ	Gain	Isolation	Input Return Loss	Output Return Loss	Stability		IP-3 Output	1dB Comp. Output	Noise Figure
					K	Measure			
(MHz)	(dB)	(dB)	(dB)	(dB)			(dBm)	(dBm)	(dB)
100	10.21	33.60	1.47	2.86	1.54	0.76	20.22	7.83	4.68
200	17.88	25.45	7.53	10.29	1.17	0.84	22.25	9.81	1.60
300	18.96	24.16	13.98	13.37	1.12	0.68	23.26	11.17	1.25
400	19.20	23.80	17.20	13.18	1.10	0.61	24.03	12.21	1.02
500	19.26	23.66	17.22	12.82	1.09	0.58	23.95	13.08	1.04
600	19.26	23.61	16.39	12.42	1.09	0.56	24.07	13.64	1.13
700	19.25	23.56	16.14	12.51	1.09	0.56	23.94	14.00	1.01
800	19.22	23.55	15.86	12.54	1.09	0.56	24.29	14.27	1.03
900	19.20	23.52	15.73	12.73	1.09	0.57	24.62	14.42	0.92
1000	19.18	23.51	15.80	12.96	1.09	0.57	23.52	14.61	0.97
1200	19.10	23.51	15.86	13.24	1.09	0.59	24.23	14.71	1.03
1400	19.00	23.53	15.70	13.63	1.10	0.61	24.22	14.83	1.10
1600	18.90	23.55	15.97	14.28	1.10	0.63	23.90	14.81	1.10
2000	18.68	23.60	16.20	16.16	1.12	0.68	23.65	14.75	1.07
2200	18.54	23.64	16.16	16.89	1.12	0.71	22.66	14.61	1.09
2600	18.28	23.73	15.83	17.21	1.14	0.75	22.90	14.46	1.15
2800	18.14	23.78	15.42	16.73	1.15	0.76	22.71	14.26	1.22
3000	18.00	23.84	14.94	16.03	1.16	0.77	22.52	14.07	1.12
3200	17.87	23.90	14.74	14.92	1.17	0.77	21.92	13.85	1.10
3400	17.74	23.95	15.19	13.78	1.18	0.76	23.00	13.94	1.06
3600	17.61	24.04	15.39	12.81	1.19	0.76	22.67	14.00	1.10
3800	17.50	24.10	15.79	12.30	1.20	0.76	23.18	14.20	1.07
4000	17.37	24.15	16.38	12.06	1.22	0.76	22.89	14.24	1.12
4200	17.27	24.24	16.66	11.70	1.23	0.76	21.74	14.02	1.11
4400	17.16	24.30	17.63	11.37	1.24	0.76	21.54	13.96	1.16
4600	17.05	24.40	18.47	11.14	1.26	0.76	21.94	13.78	1.15
4800	16.91	24.53	19.15	10.64	1.27	0.77	21.85	13.81	1.21
5000	16.75	24.68	18.34	10.27	1.29	0.78	22.20	13.78	1.19
5200	16.62	24.83	17.58	10.12	1.30	0.79	21.42	13.55	1.36
5400	16.46	24.99	16.42	10.08	1.32	0.81	20.60	13.04	1.38
5600	16.15	25.38	14.14	9.64	1.36	0.85	19.54	11.10	1.53
5800	16.00	25.59	12.23	9.83	1.37	0.89	19.92	10.58	1.64
6000	15.66	26.00	9.93	9.90	1.39	0.95	20.09	10.77	1.76

Typical Performance Data

Definitions:

Input Return Loss = -S11 (dB)

Gain(Power Gain) = S21 (dB)

Reverse Isolation = -S12 (dB)

Output Return Loss = -S22 (dB)

TEST CONDITIONS: Vd = 2.75V, Ve = 3V, Id = 39.21mA @ Temperature = -45°C

FREQ	Gain	Isolation	Input Return Loss	Output Return Loss	Stability		IP-3 Output	1dB Comp. Output	Noise Figure
					K	Measure			
(MHz)	(dB)	(dB)	(dB)	(dB)			(dBm)	(dBm)	(dB)
100	9.69	33.05	1.46	3.00	1.56	0.79	16.15	6.19	4.76
200	17.22	25.02	7.07	10.91	1.17	0.88	20.15	8.16	1.65
300	18.35	23.66	12.93	14.95	1.12	0.72	21.76	9.54	1.31
400	18.63	23.26	16.87	15.03	1.10	0.64	22.75	10.52	1.06
500	18.71	23.09	17.96	14.64	1.10	0.61	22.93	11.38	1.07
600	18.72	23.03	17.71	14.15	1.09	0.59	23.08	11.90	1.14
700	18.70	22.97	17.48	14.27	1.09	0.59	23.04	12.34	1.01
800	18.68	22.96	17.20	14.29	1.09	0.59	23.34	12.59	1.02
900	18.65	22.93	16.90	14.55	1.09	0.60	23.66	12.78	0.96
1000	18.62	22.93	16.75	14.82	1.09	0.61	22.73	13.06	1.01
1200	18.53	22.94	16.59	15.14	1.09	0.62	23.36	13.23	1.05
1400	18.41	22.98	15.98	15.56	1.10	0.65	23.36	13.36	1.10
1600	18.28	23.03	15.73	16.21	1.10	0.67	23.07	13.38	1.17
2000	18.01	23.14	14.77	17.86	1.12	0.73	22.77	13.37	1.12
2200	17.85	23.20	14.26	17.97	1.12	0.75	21.88	13.32	1.09
2600	17.52	23.34	13.32	16.54	1.14	0.79	21.99	13.25	1.18
2800	17.36	23.42	12.82	15.51	1.15	0.80	21.76	13.15	1.21
3000	17.21	23.49	12.41	14.61	1.16	0.81	21.66	13.16	1.16
3200	17.06	23.55	12.28	13.55	1.16	0.81	21.10	13.10	1.16
3400	16.94	23.62	12.60	12.52	1.17	0.80	21.99	12.92	1.11
3600	16.81	23.70	12.82	11.66	1.19	0.79	21.73	12.90	1.18
3800	16.69	23.76	13.15	11.23	1.20	0.79	22.24	12.97	1.13
4000	16.56	23.81	13.53	10.98	1.21	0.79	21.99	12.98	1.15
4200	16.45	23.92	13.74	10.69	1.23	0.79	20.98	12.88	1.18
4400	16.34	23.99	14.34	10.41	1.24	0.79	20.85	12.85	1.21
4600	16.20	24.06	14.71	10.26	1.26	0.79	21.13	12.62	1.24
4800	16.05	24.24	14.97	9.78	1.27	0.80	21.09	12.55	1.25
5000	15.87	24.44	14.30	9.42	1.29	0.81	21.41	12.47	1.26
5200	15.70	24.60	13.69	9.26	1.31	0.83	20.65	12.36	1.42
5400	15.51	24.81	12.81	9.19	1.33	0.85	19.88	11.99	1.46
5600	15.14	25.22	11.22	8.81	1.36	0.89	18.70	10.52	1.61
5800	14.94	25.49	9.82	8.87	1.37	0.93	19.13	10.11	1.71
6000	14.50	25.98	8.08	8.82	1.40	0.99	19.28	10.14	1.85

Typical Performance Data

Definitions:

Input Return Loss = -S11 (dB)

Gain(Power Gain) = S21 (dB)

Reverse Isolation = -S12 (dB)

Output Return Loss = -S22 (dB)

TEST CONDITIONS: Vd = 3.25V, Ve = 3V, Id = 43.90mA @ Temperature = -45°C

FREQ	Gain	Isolation	Input Return Loss	Output Return Loss	Stability		IP-3 Output	1dB Comp. Output	Noise Figure
					K	Measure			
(MHz)	(dB)	(dB)	(dB)	(dB)	K	Measure	(dBm)	(dBm)	(dB)
100	10.36	33.74	1.47	2.93	1.56	0.77	22.45	9.51	4.55
200	18.06	25.58	7.60	10.50	1.17	0.84	23.93	11.56	1.55
300	19.14	24.30	14.18	13.64	1.12	0.68	24.76	12.92	1.19
400	19.36	23.96	17.35	13.42	1.10	0.61	25.60	13.95	0.98
500	19.42	23.83	17.22	13.01	1.10	0.58	25.37	14.83	1.02
600	19.42	23.78	16.37	12.60	1.09	0.57	25.52	15.31	1.13
700	19.40	23.74	16.15	12.69	1.09	0.57	25.19	15.69	0.98
800	19.38	23.72	15.86	12.71	1.09	0.57	25.60	15.90	0.97
900	19.37	23.69	15.78	12.91	1.09	0.57	26.06	15.92	0.94
1000	19.34	23.68	15.85	13.13	1.09	0.58	24.55	16.14	0.98
1200	19.26	23.68	15.98	13.42	1.10	0.59	25.53	16.16	1.02
1400	19.17	23.69	15.91	13.80	1.10	0.61	25.59	16.28	1.05
1600	19.07	23.71	16.30	14.43	1.11	0.63	25.15	16.27	1.09
2000	18.87	23.76	16.82	16.38	1.12	0.68	25.05	16.23	1.04
2200	18.74	23.78	16.92	17.14	1.13	0.70	23.81	16.17	1.10
2600	18.49	23.86	16.67	17.55	1.14	0.73	24.28	16.04	1.14
2800	18.35	23.92	16.18	17.09	1.15	0.75	24.02	15.88	1.17
3000	18.22	23.97	15.60	16.39	1.16	0.76	23.68	16.01	1.11
3200	18.08	24.02	15.34	15.25	1.17	0.76	23.08	15.66	1.09
3400	17.96	24.08	15.69	14.04	1.18	0.75	24.41	15.46	1.06
3600	17.84	24.17	15.81	13.07	1.19	0.75	24.09	15.56	1.11
3800	17.72	24.22	16.20	12.57	1.21	0.75	24.70	15.87	1.06
4000	17.60	24.26	16.77	12.30	1.22	0.75	24.31	16.06	1.09
4200	17.50	24.36	17.14	11.96	1.23	0.75	22.97	15.97	1.09
4400	17.40	24.42	18.23	11.62	1.25	0.75	22.61	15.85	1.13
4600	17.28	24.47	19.24	11.45	1.26	0.76	23.23	15.48	1.14
4800	17.17	24.63	20.27	10.89	1.28	0.76	23.24	15.69	1.18
5000	17.02	24.80	19.68	10.51	1.29	0.77	23.67	15.63	1.15
5200	16.90	24.92	19.13	10.38	1.31	0.78	22.85	15.54	1.34
5400	16.76	25.08	18.04	10.33	1.33	0.80	21.75	15.28	1.38
5600	16.47	25.43	15.47	9.94	1.36	0.83	20.71	13.74	1.47
5800	16.35	25.63	13.35	10.14	1.37	0.87	21.31	12.52	1.59
6000	16.04	26.01	10.77	10.25	1.39	0.93	21.63	12.94	1.72

Typical Performance Data

Definitions:

Input Return Loss = -S11 (dB)

Gain(Power Gain) = S21 (dB)

Reverse Isolation = -S12 (dB)

Output Return Loss = -S22 (dB)

TEST CONDITIONS: Vd = Ve = 3.00V, Id = 39.23mA @ Temperature = +85°C

FREQ	Gain	Isolation	Input Return Loss	Output Return Loss	Stability		IP-3 Output	1dB Comp. Output	Noise Figure
					K	Measure			
(MHz)	(dB)	(dB)	(dB)	(dB)	K	Measure	(dBm)	(dBm)	(dB)
100	10.80	34.40	1.66	3.47	1.78	0.86	22.36	8.67	5.60
200	18.19	26.59	6.30	11.79	1.21	0.95	24.61	11.14	2.23
300	19.53	25.07	10.80	19.67	1.14	0.78	25.63	12.65	1.87
400	19.87	24.61	13.62	24.69	1.11	0.70	26.21	13.52	1.58
500	19.99	24.42	15.00	25.86	1.10	0.67	25.87	14.19	1.54
600	20.00	24.34	15.62	25.31	1.10	0.66	25.92	14.48	1.60
700	19.97	24.29	15.59	25.13	1.09	0.66	25.67	14.73	1.57
800	19.91	24.28	15.49	24.85	1.10	0.67	25.99	14.85	1.56
900	19.85	24.27	15.14	24.78	1.10	0.68	26.37	14.88	1.51
1000	19.76	24.29	14.77	24.42	1.10	0.69	25.13	15.04	1.58
1200	19.57	24.33	13.93	23.51	1.10	0.72	25.87	15.06	1.64
1400	19.34	24.39	13.18	21.98	1.11	0.75	25.84	15.10	1.73
1600	19.09	24.45	12.51	20.27	1.12	0.78	25.51	15.12	1.76
2000	18.56	24.62	11.27	17.07	1.14	0.83	25.51	15.05	1.76
2200	18.27	24.71	10.71	15.62	1.15	0.85	24.44	15.04	1.85
2600	17.70	24.88	9.91	13.27	1.17	0.88	24.85	14.86	1.95
2800	17.42	24.99	9.63	12.30	1.19	0.89	24.64	14.74	2.02
3000	17.15	25.07	9.43	11.49	1.21	0.89	24.21	14.81	1.99
3200	16.90	25.14	9.29	10.82	1.22	0.89	23.91	14.58	2.01
3400	16.67	25.23	9.29	10.26	1.25	0.88	24.81	14.43	2.00
3600	16.45	25.28	9.39	9.80	1.27	0.88	24.51	14.57	2.11
3800	16.26	25.33	9.58	9.50	1.29	0.87	24.93	14.68	2.06
4000	16.05	25.36	9.94	9.28	1.31	0.86	24.61	14.61	2.12
4200	15.89	25.38	10.29	9.04	1.33	0.86	23.67	14.54	2.14
4400	15.73	25.43	10.66	8.84	1.35	0.86	23.51	14.34	2.17
4600	15.54	25.49	10.96	8.70	1.37	0.86	24.11	14.15	2.20
4800	15.32	25.62	10.98	8.53	1.40	0.87	23.76	14.07	2.20
5000	15.05	25.80	10.63	8.33	1.42	0.88	24.20	13.96	2.28
5200	14.73	26.04	9.97	8.14	1.45	0.90	23.55	13.66	2.51
5400	14.33	26.33	9.09	7.95	1.49	0.93	22.15	12.91	2.63
5600	13.83	26.78	7.93	7.81	1.55	0.97	21.92	12.14	2.80
5800	13.30	27.26	6.90	7.51	1.60	1.00	22.33	12.05	3.02
6000	12.62	27.89	5.91	7.15	1.68	1.03	21.96	11.94	3.26

Typical Performance Data

Definitions:

Input Return Loss = -S11 (dB)

Gain(Power Gain) = S21 (dB)

Reverse Isolation = -S12 (dB)

Output Return Loss = -S22 (dB)

TEST CONDITIONS: Vd = 2.75V, Ve = 3V, Id = 37.62mA @ Temperature = +85°C

FREQ	Gain	Isolation	Input Return Loss	Output Return Loss	Stability		IP-3 Output	1dB Comp. Output	Noise Figure
					K	Measure			
(MHz)	(dB)	(dB)	(dB)	(dB)			(dBm)	(dBm)	(dB)
100	10.54	34.27	1.65	3.46	1.80	0.86	19.36	7.13	5.60
200	17.90	26.49	6.12	11.72	1.22	0.96	23.48	9.56	2.27
300	19.25	24.93	10.37	19.61	1.14	0.79	24.74	11.08	1.89
400	19.62	24.44	12.98	25.31	1.11	0.72	25.44	11.98	1.60
500	19.73	24.24	14.26	27.13	1.10	0.69	25.19	12.64	1.53
600	19.75	24.16	14.81	26.52	1.10	0.68	25.21	12.94	1.59
700	19.71	24.11	14.79	26.15	1.09	0.68	25.02	13.21	1.57
800	19.66	24.10	14.70	25.63	1.09	0.68	25.31	13.34	1.57
900	19.58	24.10	14.34	25.31	1.09	0.69	25.67	13.40	1.52
1000	19.50	24.11	13.99	24.63	1.10	0.70	24.57	13.55	1.57
1200	19.29	24.15	13.19	23.23	1.10	0.73	25.23	13.58	1.64
1400	19.05	24.22	12.45	21.41	1.11	0.77	25.24	13.61	1.75
1600	18.79	24.29	11.80	19.62	1.11	0.80	24.91	13.63	1.81
2000	18.23	24.46	10.64	16.45	1.13	0.85	24.89	13.55	1.82
2200	17.93	24.56	10.13	15.06	1.14	0.87	23.86	13.52	1.85
2600	17.34	24.74	9.40	12.81	1.17	0.90	24.26	13.33	1.99
2800	17.04	24.84	9.14	11.88	1.19	0.90	24.05	13.20	2.08
3000	16.76	24.93	8.97	11.11	1.20	0.91	23.60	13.24	2.01
3200	16.50	24.99	8.87	10.47	1.22	0.90	23.31	13.06	2.03
3400	16.27	25.08	8.89	9.94	1.24	0.90	24.17	12.91	2.06
3600	16.05	25.13	9.00	9.50	1.26	0.89	23.88	12.97	2.14
3800	15.85	25.17	9.20	9.21	1.28	0.88	24.31	13.00	2.10
4000	15.65	25.19	9.53	9.00	1.31	0.88	24.02	12.92	2.17
4200	15.47	25.22	9.86	8.77	1.33	0.87	23.13	12.91	2.18
4400	15.30	25.26	10.20	8.57	1.35	0.87	23.00	12.67	2.19
4600	15.10	25.33	10.44	8.43	1.37	0.87	23.46	12.50	2.26
4800	14.87	25.46	10.41	8.26	1.40	0.88	23.23	12.40	2.30
5000	14.58	25.65	10.03	8.07	1.42	0.89	23.64	12.23	2.36
5200	14.24	25.89	9.37	7.88	1.45	0.92	23.02	11.99	2.56
5400	13.82	26.20	8.53	7.68	1.49	0.94	21.65	11.31	2.70
5600	13.29	26.66	7.45	7.54	1.55	0.98	21.31	10.64	2.91
5800	12.74	27.16	6.50	7.25	1.60	1.01	21.70	10.50	3.11
6000	12.02	27.79	5.59	6.90	1.69	1.04	21.37	10.35	3.33

Typical Performance Data

Definitions:

Input Return Loss = -S11 (dB)

Gain(Power Gain) = S21 (dB)

Reverse Isolation = -S12 (dB)

Output Return Loss = -S22 (dB)

TEST CONDITIONS: Vd = 3.25V, Ve = 3V, Id = 40.69mA @ Temperature = +85°C

FREQ	Gain	Isolation	Input Return Loss	Output Return Loss	Stability		IP-3 Output	1dB Comp. Output	Noise Figure
					K	Measure			
(MHz)	(dB)	(dB)	(dB)	(dB)	K	Measure	(dBm)	(dBm)	(dB)
100	10.96	34.56	1.66	3.57	1.81	0.88	23.41	9.89	5.55
200	18.39	26.74	6.46	12.03	1.22	0.94	25.34	12.38	2.21
300	19.71	25.23	11.19	20.03	1.14	0.77	26.28	13.91	1.79
400	20.05	24.78	14.19	24.76	1.12	0.70	26.88	14.80	1.59
500	20.16	24.60	15.71	25.57	1.11	0.67	26.47	15.41	1.53
600	20.18	24.52	16.34	24.98	1.10	0.66	26.47	15.65	1.55
700	20.14	24.48	16.36	24.85	1.10	0.66	26.23	15.90	1.56
800	20.09	24.47	16.26	24.67	1.10	0.66	26.56	16.01	1.57
900	20.03	24.46	15.91	24.74	1.10	0.67	26.93	15.99	1.51
1000	19.95	24.47	15.54	24.55	1.10	0.68	25.60	16.15	1.56
1200	19.76	24.51	14.69	23.95	1.11	0.71	26.41	16.14	1.65
1400	19.56	24.57	13.89	22.62	1.12	0.74	26.37	16.19	1.72
1600	19.32	24.63	13.22	20.95	1.12	0.76	26.01	16.24	1.76
2000	18.82	24.78	11.91	17.69	1.14	0.81	26.01	16.14	1.78
2200	18.54	24.87	11.31	16.20	1.16	0.84	24.88	16.15	1.86
2600	17.99	25.04	10.44	13.74	1.18	0.86	25.31	15.93	1.97
2800	17.72	25.15	10.11	12.72	1.20	0.87	25.14	15.77	2.02
3000	17.45	25.23	9.87	11.88	1.22	0.87	24.68	15.95	1.98
3200	17.20	25.30	9.70	11.18	1.24	0.87	24.40	15.56	2.01
3400	16.98	25.39	9.68	10.60	1.26	0.87	25.34	15.48	1.99
3600	16.77	25.45	9.74	10.12	1.28	0.87	24.97	15.71	2.12
3800	16.57	25.51	9.93	9.83	1.30	0.86	25.39	15.90	2.04
4000	16.37	25.53	10.29	9.61	1.33	0.86	25.04	15.85	2.08
4200	16.21	25.56	10.67	9.37	1.35	0.85	24.03	15.74	2.11
4400	16.06	25.61	11.08	9.17	1.37	0.85	23.89	15.56	2.16
4600	15.89	25.67	11.44	9.04	1.39	0.85	24.47	15.30	2.18
4800	15.68	25.79	11.56	8.87	1.42	0.86	24.01	15.30	2.23
5000	15.43	25.97	11.26	8.68	1.44	0.87	24.47	15.18	2.25
5200	15.13	26.19	10.59	8.50	1.47	0.89	23.76	14.84	2.46
5400	14.76	26.47	9.68	8.31	1.51	0.92	22.41	14.00	2.58
5600	14.28	26.91	8.43	8.16	1.57	0.96	22.18	13.20	2.77
5800	13.77	27.39	7.30	7.86	1.62	1.00	22.58	13.14	2.96
6000	13.11	28.02	6.24	7.49	1.71	1.03	22.18	13.08	3.18

Typical Performance Curves

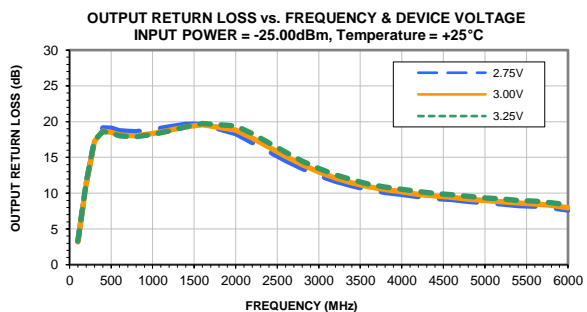
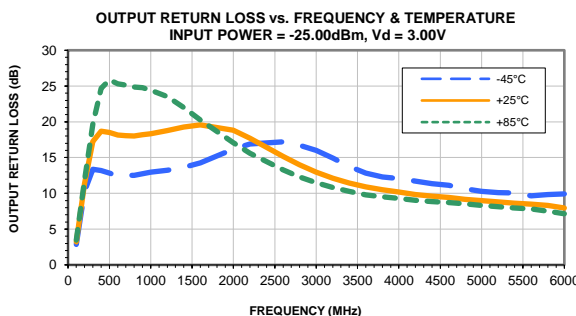
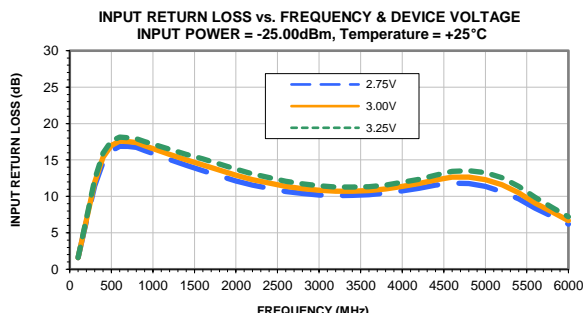
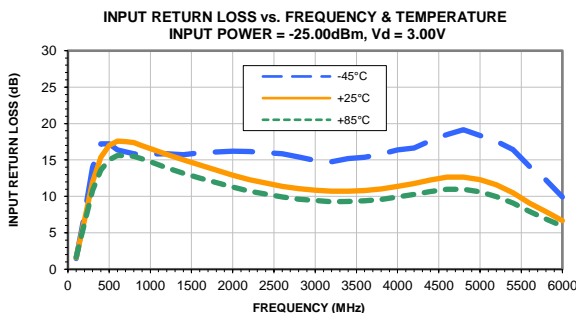
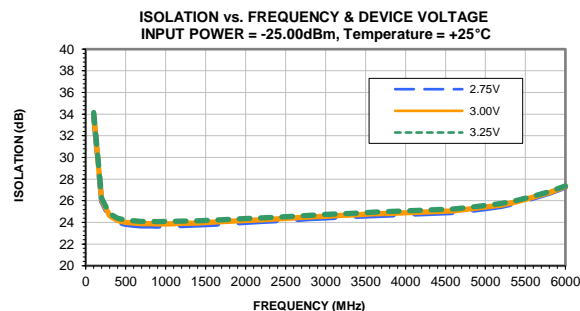
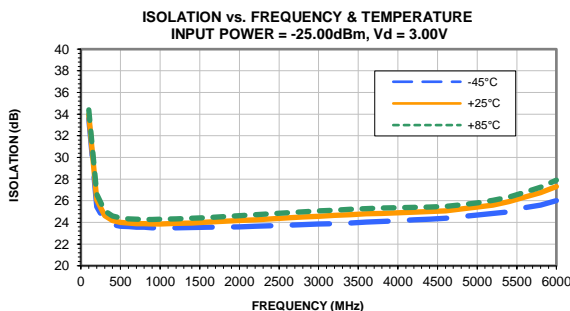
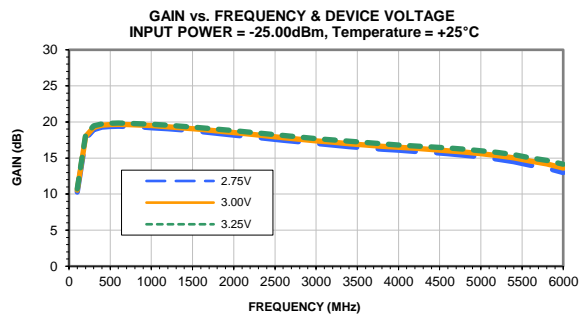
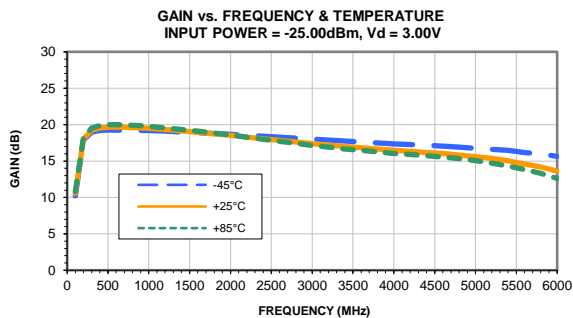

Typical Performance Curves

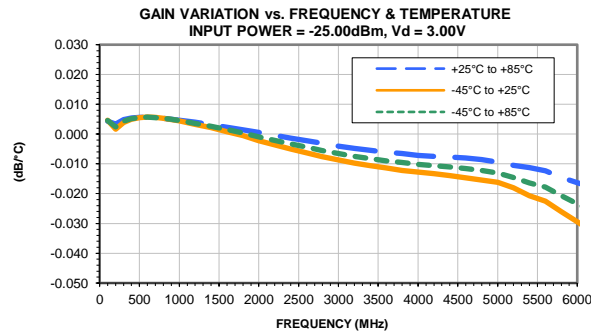
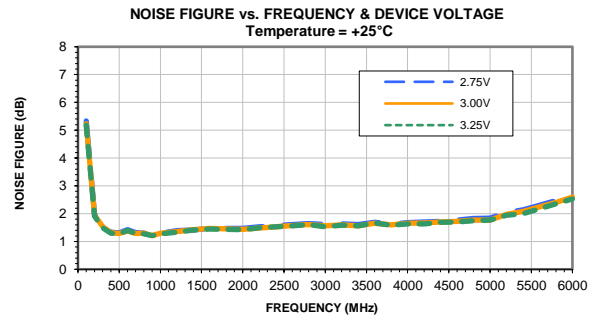
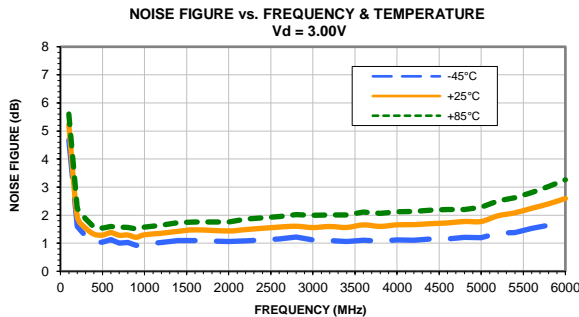
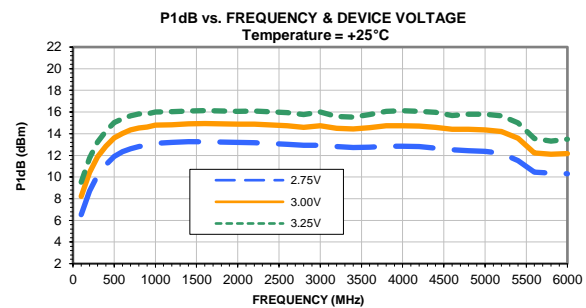
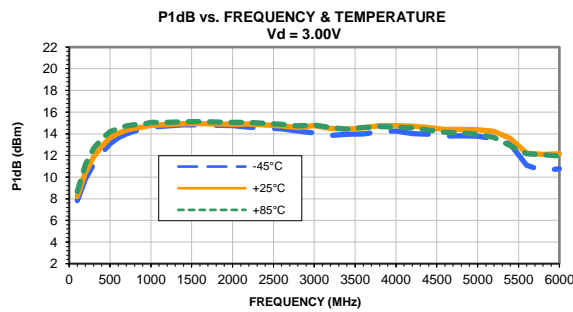
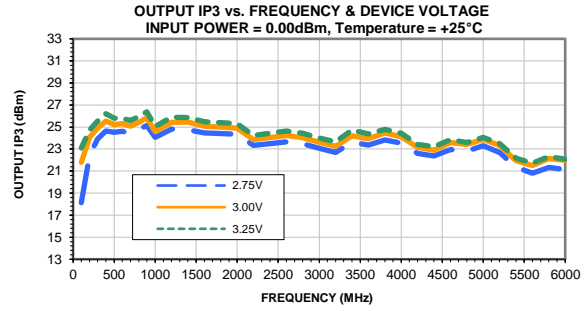
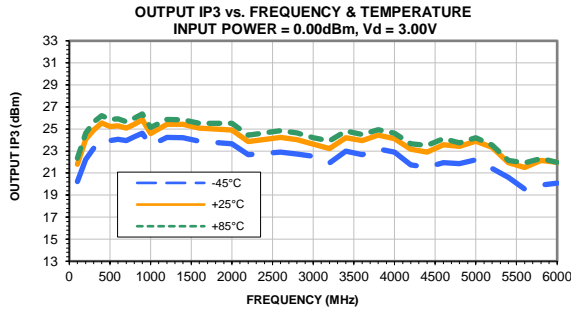

Outline Dimensions



PCB Land Pattern

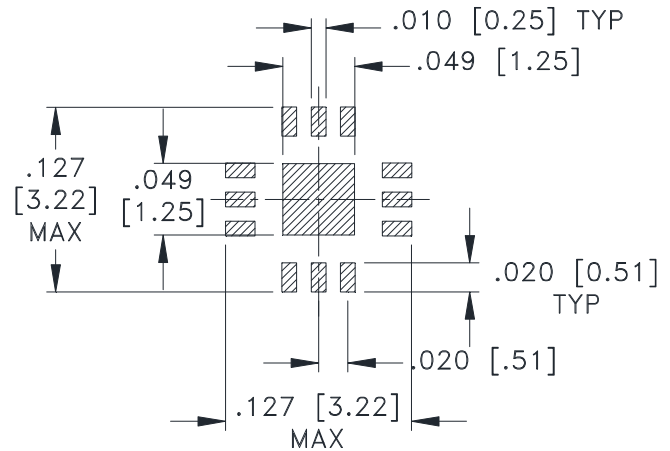

SUGGESTED LAYOUT,
TOLERANCE TO BE WITHIN $\pm .002$

Weight: .02 Grams

Dimensions are in inches (mm). Tolerances: 2Pl. $\pm .01$; 3 Pl. $\pm .004$

Notes:

1. Case material: Plastic.
2. Termination finish:
 - For RoHS Case Styles: Tin-Silver alloy plate over Nickel barrier or Matte-Tin. All models, (+) suffix. See Data sheet.
 - For RoHS-5 Case Styles: Tin-Lead plate. All models, no (+) suffix.

Mini-Circuits®

Distribution Centers NORTH AMERICA 800-654-7949 • 417-335-5935 • Fax 417-335-5945 • EUROPE 44-1252-832600 • Fax 44-1252-837010

Mini-Circuits ISO 9001 & ISO 14001 Certified

INTERNET <http://www.minicircuits.com>

P.O. Box 350166, Brooklyn, New York 11235-0003 (718) 934-4500 Fax (718) 332-4661

Tape & Reel Packaging TR-F66



Tape Width, mm	Device Cavity Pitch, mm	Reel Size, inches	Devices per Reel see note	
8	4	7	Small quantity standard	20
				50
				100
				200
				500
		7	Standard	1000, 2000, 3000

Note: Please consult individual model data sheet to determine device per reel availability.

Mini-Circuits carrier tape materials provide protection from ESD (Electro-Static Discharge) during handling and transportation. Tapes are static dissipative and comply with industry standards EIA-481/EIA-541.

Go to: www.minicircuits.com/pages/pdfs/tape.pdf

Mini-Circuits®

INTERNET <http://www.minicircuits.com>

P.O. Box 350166, Brooklyn, New York 11235-0003 (718) 934-4500 Fax (718) 332-4661

Distribution Centers NORTH AMERICA 800-654-7949 • 417-335-5935 • Fax 417-335-5945 • EUROPE 44-1252-832600 • Fax 44-1252-837010

Mini-Circuits ISO 9001 & ISO 14001 Certified

THIRD ANGLE PROJECTION

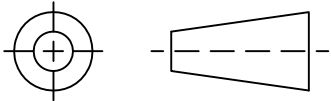

REVISIONS

REV	ECN No.	DESCRIPTION	DATE	DR	AUTH
OR	M146226	NEW RELEASE	05/05/14	ITG	SK

SUGGESTED MOUNTING CONFIGURATION
FOR DQ1225 CASE STYLE, "12AM01" PIN CODE

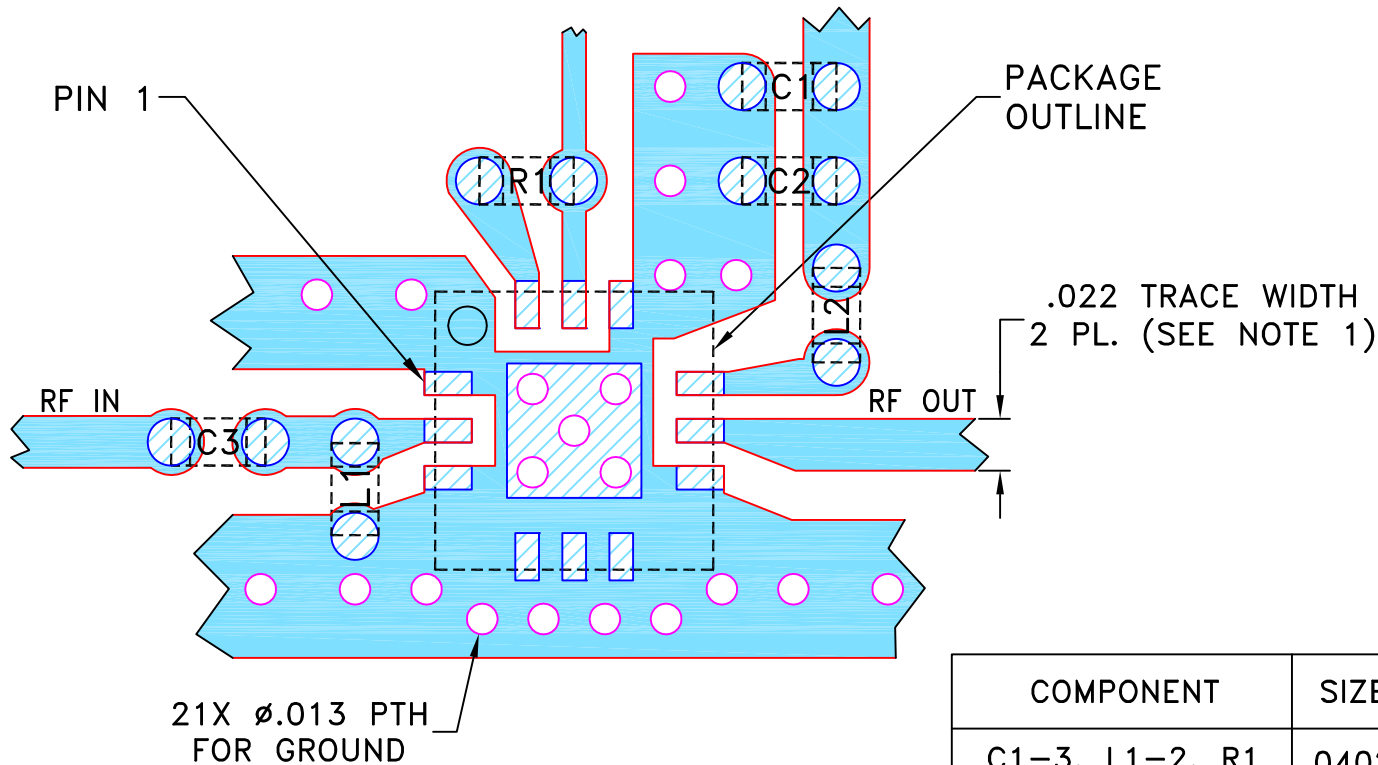

COMPONENT	SIZE
C1-3, L1-2, R1	0402

NOTES:

1. TRACE WIDTH IS SHOWN FOR ROGERS R04350B WITH DIELECTRIC THICKNESS .010" ± .001". COPPER: 1/2 OZ. EACH SIDE. FOR OTHER MATERIALS TRACE WIDTH MAY NEED TO BE MODIFIED.
2. CHIP COMPONENT FOOT PRINTS SHOWN FOR REFERENCE. FOR COMPONENT VALUES REFER TO TB-779+.
2. BOTTOM SIDE OF THE PCB IS CONTINUOUS GROUND PLANE.

 DENOTES PCB COPPER LAYOUT WITH SMOBC (SOLDER MASK OVER BARE COPPER).

 DENOTES COPPER LAND PATTERN FREE OF SOLDER MASK.

UNLESS OTHERWISE SPECIFIED	INITIALS		DATE
DIMENSIONS ARE IN INCHES	DRAWN	ITG	04/28/14
TOLERANCES ON:	CHECKED	IL	04/30/14
2 PL DECIMALS ±	APPROVED	SK	05/05/14
3 PL DECIMALS ± .005			
ANGLES ±			
FRACTIONS ±			

 **Mini-Circuits®** 13 Neptune Avenue
 Brooklyn NY 11235

PL, 12AM01, DQ1225, TB-779+

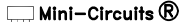
 Mini-Circuits®
 THIS DOCUMENT AND ITS CONTENTS ARE THE PROPERTY OF MINI-CIRCUITS. EXCEPT FOR USE EXPRESSLY GRANTED, IN WRITING, TO ITS VENDORS, VENDEE AND THE UNITED STATES GOVERNMENT, MINI-CIRCUITS RESERVES ALL PROPRIETARY DESIGN, USE, MANUFACTURING AND REPRODUCTION RIGHTS THERETO. THESE CONTENTS SHALL NOT BE USED, DUPLICATED OR DISCLOSED TO ANY OUTSIDE PARTY, IN WHOLE OR IN PART, WITHOUT WRITTEN PERMISSION OF MINI-CIRCUITS.

SIZE A	CODE IDENT 15542	DRAWING NO: 98-PL-421	REV: OR
FILE: 98PL421	SCALE: 12:1	SHEET: 1 OF 1	

Evaluation Board and Circuit

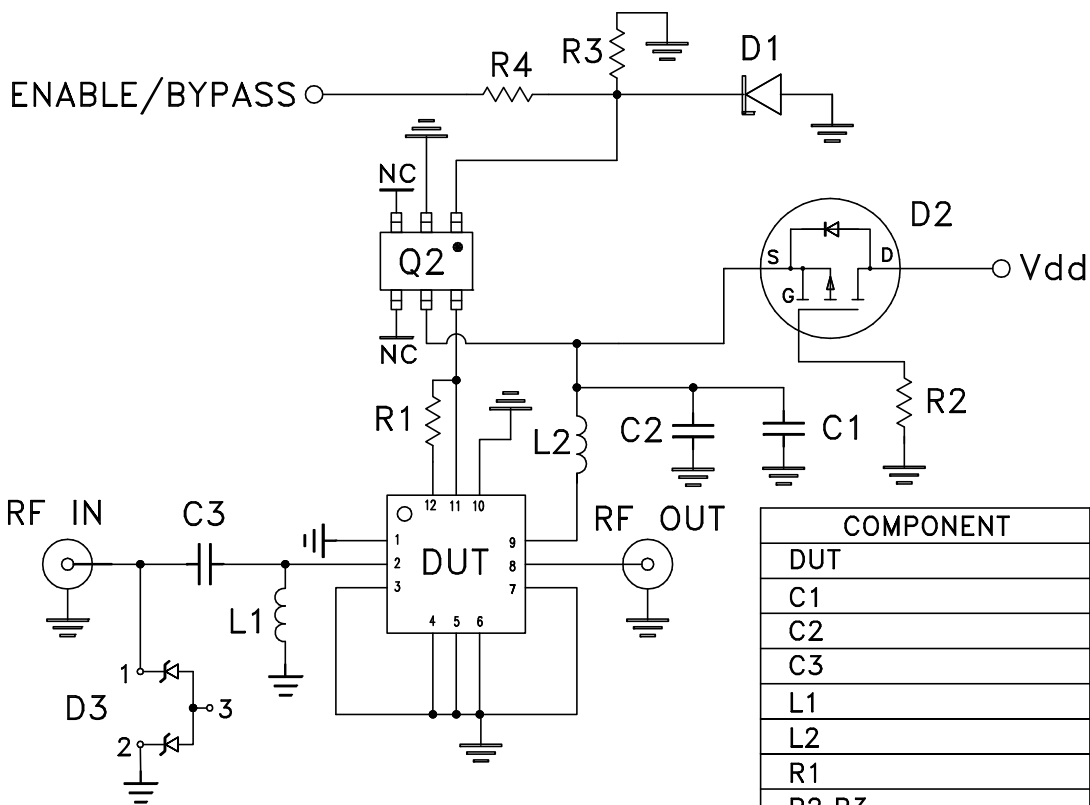
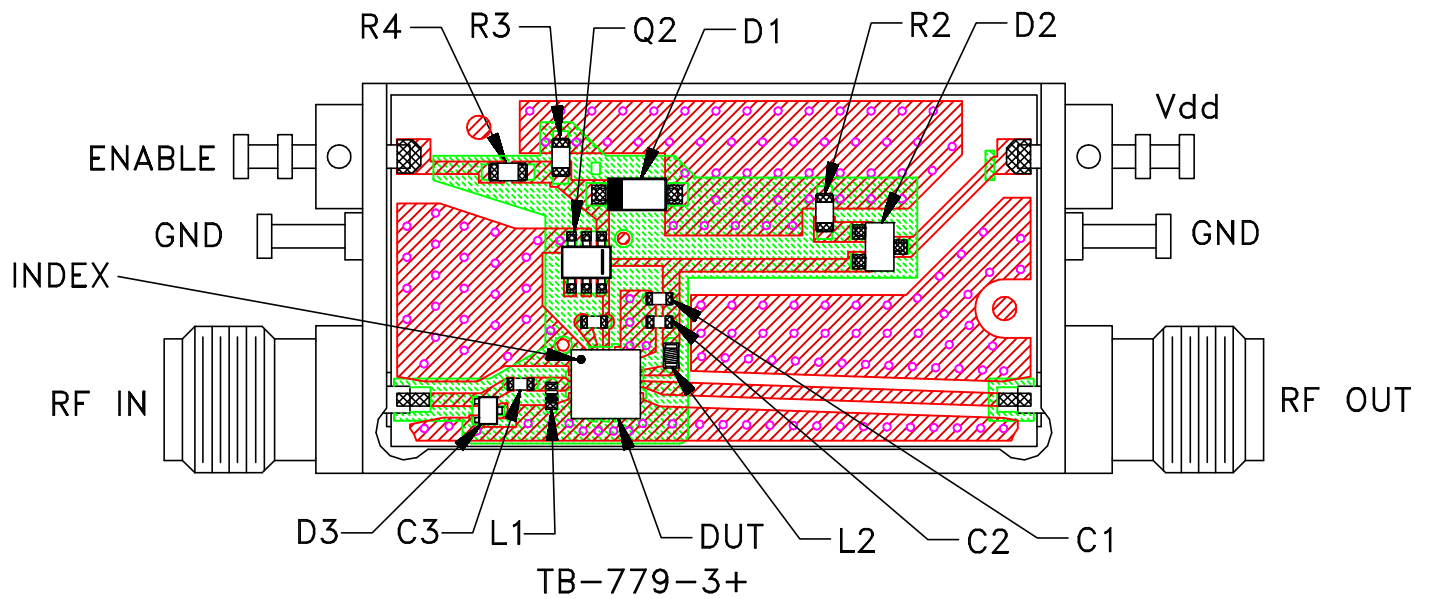

Schematic Diagram

COMPONENT		VALUE	SIZE
DUT		TSS-53LNB+	
C1		.1 uF	SIZE
C2		10 pF	
C3		.001 uF	
L1		47 nH	0402
L2		56 nH	
R1		3.92 kOhm	0603
R2,R3		10 kOhm	
R4		1 kOhm	
D1	MCL	B40-28-5230B+	0603
	ON SEMI	MMSZ5230BT1G	
D2	MCL	B43-4101PT1+	
	ON SEMI	NTS4101PT1G	
D3	MCL	B40-ESD7L5+	
	ON SEMI	ESD7L5.0DT5G	
Q2	MCL	B49-SN74-17+	
	TEXAS INSTRUMENT	SN74LVC2G17DCKR	

Notes:

- 50 Ohm SMA Female connectors.
- PCB Material: R04350 or equivalent, Dielectric Constant=3.5, Thickness=.010 inch.

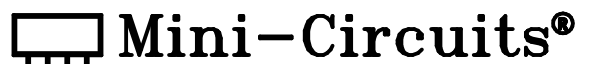

All Mini-Circuits products are manufactured under exacting quality assurance and control standards, and are capable of meeting published specifications after being subjected to any or all of the following physical and environmental test.

Specification	Test/Inspection Condition	Reference/Spec
Operating Temperature	-40° to 85° C Ambient Environment	Individual Model Data Sheet
Storage Temperature	-65° to 150° C Ambient Environment	Individual Model Data Sheet
Autoclave	15 psig, 100% RH, 121°C, 96 hours	JESD22-A102-C, Condition C
Temperature Cycling	-65° to 150°C, 100 cycles	JESD22-A104
Temperature Humidity	85°C/ 85% RH, 168 hours	JESD22-113
Solder Reflow Heat	Sn-Pb Eutetic Process: 240°C peak Pb-Free Process: 260°C peak	J-STD-020, Table 4-1, 4-2 and 5-2; Figure 5-1
Moisture Sensitivity: Level 1	Bake at 125°C for 24 hours Soak at 85°C/85% RH for 168 hours, Reflow 3 cycles at 240°C peak (Non-RoHS) or 260°C (RoHS)	J-STD-020
Solderability	10X magnification, 95% coverage	JESD22-B102, Method 1: Dip and Look Test
Mechanical Shock	50g, 11 ms, 1/2-sine, 18 shocks: 3 each direction, each of 3 axes	MIL-STD-202, Method 213, Condition A
Vibration (High Frequency)	20g peak, 10-2000 Hz, 12 times in each of three perpendicular directions (total 36)	MIL-STD-202, Method 204, Condition D