

Wideband

Low Noise Bypass Amplifier Die

TSS-53LNB-D+

50Ω 0.5 to 6 GHz

The Big Deal

- Very wideband, 500 MHz – 6 GHz
- Ultra-flat gain, ± 0.4 dB from 700 to 2100 MHz
- Low NF over entire frequency band, 1.4 dB
- Internal bypass switching extends useable dynamic range

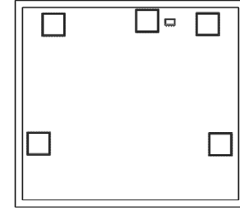

Product Overview

Mini-Circuits TSS-53LNB-D+ is a low-noise amplifier die offering industry-leading performance over its full frequency range from 500 MHz to 6 GHz. It contains internal switching, allowing the user control of the amplifier to handle both high and low signal levels by bypassing the LNA in the presence of large signals. The TSS-53LNB-D+ utilizes E-PHEMT technology to achieve excellent noise figure performance in a unique cascade configuration enabling the combination of very wide band performance and flat gain.

Key Features

Feature	Advantages
Ultra-wideband: 500 MHz – 6 GHz	Ideal for a wide range of receiver applications including military, commercial wireless, and instrumentation.
Very flat gain: ± 0.4 dB over 0.7-2.1 GHz	Ideal for broadband or multi-band applications. Just one, cost-efficient model required for multiple frequency usage.
Minimal external matching components required. 15 dB return loss typ.	Minimizes the need for external matching networks, simplifying circuit designs, and enabling the amplifier to operate over multiple bands in a single application circuit.
High IP3: 48 dBm typ. (bypass mode)	Provides enhanced linearity over broad frequency range under high signal conditions.
Internal bypass switch feature	Unique design handles low to high signal levels with minimal noise distortion.
Built-in DC blocking cap at RF-Out port & separate pads for RF-Out & Vdd	Simplifies biasing eliminates need for Bias-Tee at output.
Unpackaged Die	Enables the users to integrate amplifier directly into hybrids.



Wideband

Low Noise Bypass Amplifier Die TSS-53LNB-D+

Product Features

- Wideband: 0.5-6 GHz
- Built-in Bypass switching
- Low Noise figure: 1.3 dB typ. at 2.0 GHz
- High Gain: 21.4 dB typ. at 2 GHz
- Ultra Flat Gain: 0.4 dB from 0.7 to 2.1 GHz
- P1dB: +21 dBm typ. at 2.0 GHz
- Minimal matching components

Typical Applications

- Wireless Base Station Systems
- Test and Measurement Systems
- Multi-Band Receivers

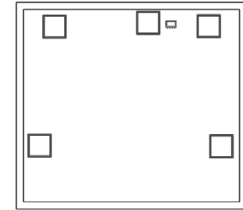

+RoHS Compliant

The +Suffix identifies RoHS Compliance. See our web site for RoHS Compliance methodologies and qualifications

Ordering Information: Refer to Last Page

General Description

TSS-53LNB-D+ (RoHS compliant) is an advanced ultra-flat gain Low Noise wideband amplifier die fabricated using E-PHEMT technology offering extremely high dynamic range over a broad frequency range. It has integrated switches enabling users to bypass the amplifier during high signal conditions. In addition, the TSS-53LNB-D+ has good input and output return loss over a broad frequency range without the need for external matching components.

Simplified Schematic and Pad description

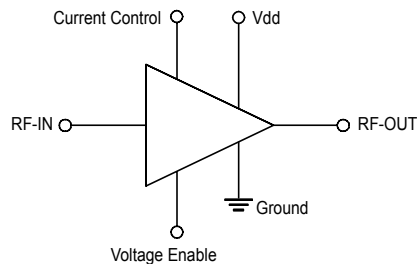

Function	Description (See Figure 2)
RF-IN	RF-Input pad. Connect to Ground Via L1. Add a DC blocking cap in series of appropriate value if required.
RF-OUT	RF-Output pad. No external DC blocking cap required.
Current Control	Current Control pad, Voltage level on this pad sets the I _{dd} . Connect to pad Voltage Enable pad via 3.92 kΩ resistor.
Voltage Enable	Voltage Enable Pad. Voltage level on this pad determines Amplifier is ON or bypassed.
Vdd	Supply Voltage Pad. Connect to Vdd via L2.
Ground	Bottom of Die

Note: 1. Bond Pad material - Gold
2. Bottom of Die - Gold plated

Electrical Specifications⁽¹⁾ at 25°C, Zo=50Ω and V=5V, unless otherwise noted

Parameter	Condition (GHz)	Amplifier-ON			Amplifier-Bypass	Units	
		Min.	Typ.	Max.	Typ.		
Frequency Range		0.5		6.0		GHz	
Noise Figure	0.5		1.4		0.8	dB	
	1.0		1.2		0.9		
	2.0		1.3		1.1		
	4.0		1.6		1.4		
	5.0		1.7		1.4		
Gain	6.0		2.2		1.7	dB	
	0.5		22.0		-0.8		
	1.0		21.9		-0.9		
	2.0		21.4		-1.1		
	4.0		19.4		-1.7		
Gain Flatness	5.0		18.4		-1.6	dB	
	6.0		17.1		-2.0		
	0.7 - 2.1		±0.4		±0.7		
	0.5		14.9		23.9		
	1.0		15.4		18.3		
Input Return Loss	2.0		21.7		14.3	dB	
	4.0		11.6		10.4		
	5.0		10.8		14.7		
	6.0		13.3		13.3		
	0.5		10.5		22.3		
Output Return Loss	1.0		11.7		17.1	dB	
	2.0		16.4		15.0		
	4.0		10.3		10.9		
	5.0		7.9		13.5		
	6.0		6.6		11.1		
Output Power @ 1dB compression AMP-ON ⁽²⁾ Input Power @ 1dB compression AMP-Bypass ^(4,5)	0.5		20.9		32.0	dBm	
	1.0		21.0		—		
	2.0		20.7		33.0		
	4.0		19.4		—		
	5.0		18.9		27.0		
Output IP3	6.0		16.4		32.0	dBm	
	0.5		34.0		45.4		
	1.0		36.3		46.1		
	2.0		35.0		45.8		
	4.0		32.2		41.2		
Device Operating Voltage (Vdd)	5.0		30.5		40.3	dBm	
	6.0		28.7		38.0		
	5.0		5.0		4.8-5.2 (5.0 typ.)		
	Device Operating Current (Id)		46	82	105		2
	Enable Voltage (Ve)			5.0			0
Enable Control Current (Ie)			2.0		0		
DC Current (Id) Variation Vs. Voltage			0.007		—		
Thermal Resistance, junction-to-ground lead			48		—		

⁽¹⁾ Measured on Mini-Circuits Die Characterization test board. See Characterization Test Circuit (Fig. 1)
⁽²⁾ Current increases at P1dB

Absolute Maximum Ratings^(3,4)

Parameter	Ratings
Operating Temperature (bottom of die)	-40°C to 85°C
Total Power Dissipation	0.7 W
Input Power	Amplifier-ON 8 dBm (continuous), 19 dBm (5 min max.)
	Amplifier Bypass 16 dBm (continuous), 29 dBm (5 min max.)
DC Voltage Vdd	7.0 V
DC Voltage Enable	7.0 V
Max. Voltage on RF-OUT Pad	15 V

⁽³⁾ Permanent damage may occur if any of these limits are exceeded.
 Electrical maximum ratings are not intended for continuous normal operation.
⁽⁴⁾ Die performance measured in industry standard 3x3 mm 12-lead package.
⁽⁵⁾ Do not exceed absolute maximum ratings.

Enable Voltage (Ve) Fig. 1

	Min.	Typ.	Max.	Units
Amplifier-ON	4.5	5.0	5.5	V
Amplifier-Bypass	0	—	0.5	V

Switching Specifications (Rise/Fall Time)

Parameter		Min.	Typ.	Max.	Units
Amplifier ON to Bypass	OFF TIME (50% Control to 10% RF)	—	50	—	ns
	FALL TIME (90 to 10% RF)	—	12	—	
Amplifier Bypass to ON	ON TIME (50% Control to 90% RF)	—	740	—	ns
	RISE TIME (10% to 90% RF)	—	240	—	
Control Voltage Leakage		—	65	—	mV

Characterization Test Circuit

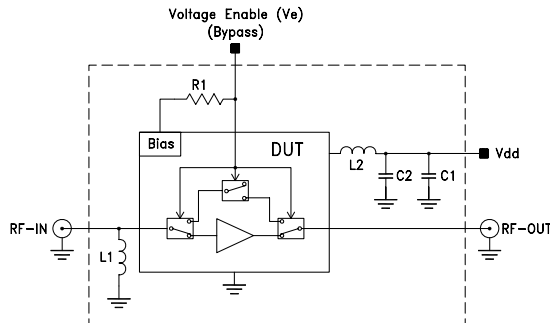

Component	Size	Value	Units
L1	0402	47	nH
L2	0402	56	nH
C1	0402	0.1	μF
C2	0402	10	pF
R1	0402	3.92	kΩ

Fig 1. Block diagram of Test Circuit used for Die characterization. Gain, Return loss, Output power at 1dB compression (P1 dB) , output IP3 (OIP3) and noise figure measured using Agilent's N5242A PNA-X microwave network analyzer.

Conditions:

1. Gain and Return loss: Pin= -25dBm
2. Output IP3 (OIP3): Two tones, spaced 1 MHz apart, 0 dBm/tone at output.
3. Switching Time: Pin=-25 dBm at 500 MHz. Venable=4.5, 5.0, 5.5V at 10 kHz. Vd=4.75, 5.0 and 5.5V. (Note 4)

Recommended Application Circuit

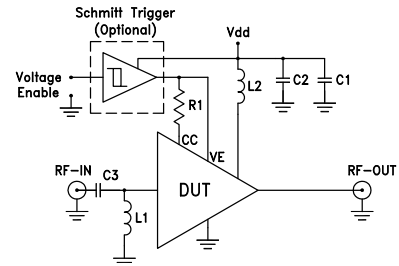

CC: Control Current
VE: Voltage Enable

Component	Size	Value	Units
L1	0402	47	nH
L2	0402	56	nH
R1	0402	3.92	kΩ
C1	0402	0.1	μF
C2	0402	10	pF
C3	0402	1000	pF
Schmitt Trigger	SN74LVC2G17DCKR	Texas Instruments	—

Fig 2. Recommended Application Circuit.

Die Layout

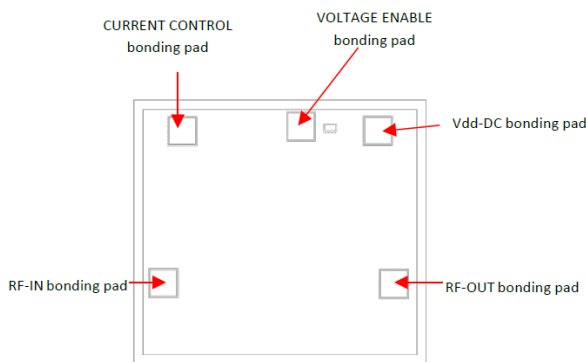

Fig 3. Die Layout

Bonding Pad Position

(Dimensions in μm, Typical)

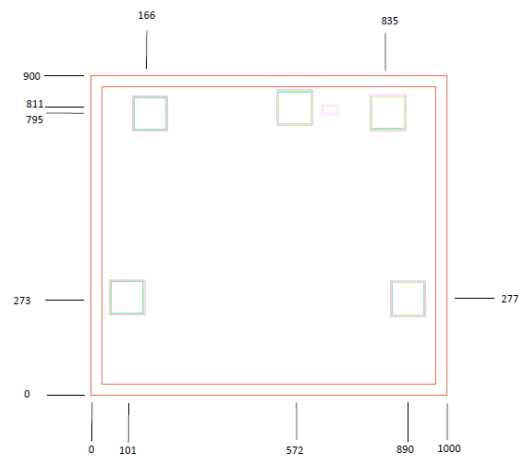

Fig 4. Bonding Pad Positions

Critical Dimensions

Parameter	Values
Die Thickness, μm	100
Die Width, μm	900
Die Length, μm	1000
Bond Pad Size, μm	100 x 100



Monolithic E-PHEMT MMIC Amplifier Die

Assembly and Handling Procedure

- Storage**
 Dice should be stored in a dry nitrogen purged desiccators or equivalent.
- ESD**
 MMIC EPHEMPT amplifier dice are susceptible to electrostatic and mechanical damage. Die are supplied in antistatic protected material, which should be opened in clean room conditions at an appropriately grounded anti-static workstation. Devices need careful handling using correctly designed collets, vacuum pickup tips or sharp antistatic tweezers to deter ESD damage to dice.
- Die Attach**
 The die mounting surface must be clean and flat. Using conductive silver filled epoxy, recommended epoxies are DieMat DM6030HK-PT/H579 or Ablestik 84-1LMISR4. Apply sufficient epoxy to meet required epoxy bond line thickness, epoxy fillet height and epoxy coverage around total die periphery. Parts shall be cured in a nitrogen filled atmosphere per manufacturer's cure condition. It is recommended to use antistatic die pick up tools only.
- Wire Bonding**
 Bond pad openings in the surface passivation above the bond pads are provided to allow wire bonding to the dice gold bond pads. Thermosonic bonding is used with minimized ultrasonic content. Bond force, time, ultrasonic power and temperature are all critical parameters. Suggested wire is pure gold, 1 mil diameter. Bonds must be made from the bond pads on the die to the package or substrate. All bond wires should be kept as short as low as reasonable to minimize performance degradation due to undesirable series inductance.

Assembly Diagram

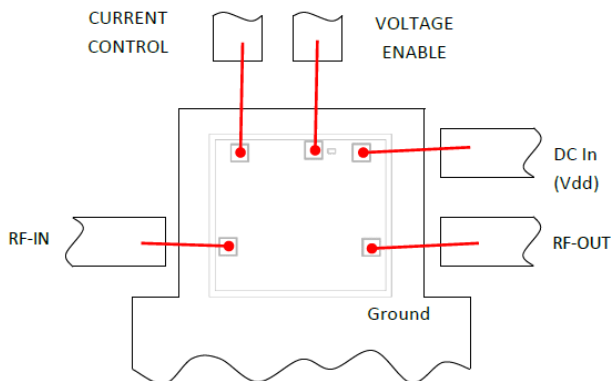

Recommended Wire Length, Typical

Wire	Wire Length (mm)	Wire Loop Height (mm)
RF-IN	0.9	0.15
DC IN (Vdd), Voltage Enable, Current Control	0.5	0.15
RF-OUT	0.6	0.15

RF Reference Plane - No port extension

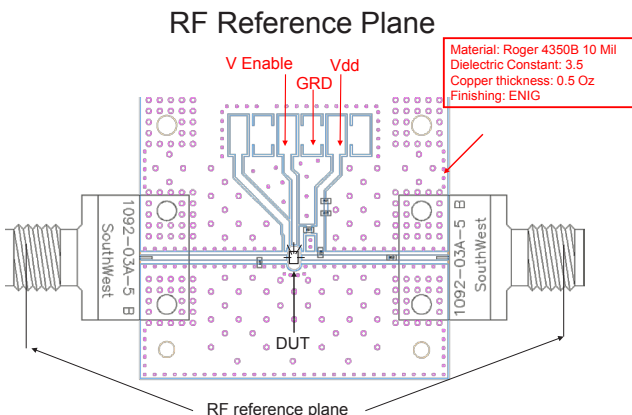

Additional Detailed Technical Information <i>additional information is available on our dash board.</i>									
Performance Data	Data Table								
	Swept Graphs								
	S-Parameter (S2P Files) Data Set with and without port extension(.zip file)								
Case Style	Die								
Die Ordering and packaging information	<table> <thead> <tr> <th>Quantity, Package</th> <th>Model No.</th> </tr> </thead> <tbody> <tr> <td>Small, Gel - Pak: 5,10,50,100 KGD*</td> <td>TSS-53LNB-DG+</td> </tr> <tr> <td>Medium†, Partial wafer: KGD*<1555</td> <td>TSS-53LNB-DP+</td> </tr> <tr> <td>Large†, Full Wafer</td> <td>TSS-53LNB-DF+</td> </tr> </tbody> </table> <p>†Available upon request contact sales representative</p> <p>Refer to AN-60-067</p>	Quantity, Package	Model No.	Small, Gel - Pak: 5,10,50,100 KGD*	TSS-53LNB-DG+	Medium†, Partial wafer: KGD*<1555	TSS-53LNB-DP+	Large†, Full Wafer	TSS-53LNB-DF+
Quantity, Package	Model No.								
Small, Gel - Pak: 5,10,50,100 KGD*	TSS-53LNB-DG+								
Medium†, Partial wafer: KGD*<1555	TSS-53LNB-DP+								
Large†, Full Wafer	TSS-53LNB-DF+								
Environmental Ratings	ENV-80								

*Known Good Dice ("KGD") means that the dice in question have been subjected to Mini-Circuits DC test performance criteria and measurement instructions and that the parametric data of such dice fall within a predefined range. While DC testing is not definitive, it does help to provide a higher degree of confidence that dice are capable of meeting typical RF electrical parameters specified by Mini-Circuits.

ESD Rating**

Human Body Model (HBM): Class 1A (250 to <500V) in accordance with ANSI/ESD STM 5.1 - 2001

** Die performance measured in industry standard 3x3 mm 12-lead package.

Additional Notes

- A. Performance and quality attributes and conditions not expressly stated in this specification document are intended to be excluded and do not form a part of this specification document.
- B. Electrical specifications and performance data contained in this specification document are based on Mini-Circuit's applicable established test performance criteria and measurement instructions.
- C. The parts covered by this specification document are subject to Mini-Circuits standard limited warranty and terms and conditions (collectively, "Standard Terms"); Purchasers of this part are entitled to the rights and benefits contained therein. For a full statement of the Standard Terms and the exclusive rights and remedies thereunder, please visit Mini-Circuits' website at www.minicircuits.com/MCLStore/terms.jsp



Typical Performance Data

Full 2-Port Extension

Definitions:

Input Return Loss = -S11 (dB)

Gain(Power Gain) = S21 (dB)

Reverse Isolation = -S12 (dB)

Output Return Loss = -S22 (dB)

TEST CONDITIONS: Vd = 5.00V, Ve = 5V, Id = 82mA @Temperature = +25°C

FREQ.	Gain	Isolation	Input Return Loss	Output Return Loss	Stability		IP-3 Output	1dB Comp. Output	Noise Figure
					K	Measure			
(MHz)	(dB)	(dB)	(dB)	(dB)	K	Measure	(dBm)	(dBm)	(dB)
200	18.64	31.15	7.90	7.97	1.70	0.88	30.78	19.06	1.96
300	21.74	27.84	12.88	11.28	1.17	0.69	32.18	20.31	1.53
400	22.27	27.18	15.99	12.50	1.12	0.62	33.06	20.76	1.44
500	22.39	26.99	17.02	12.71	1.11	0.59	34.01	20.90	1.38
600	22.42	26.90	17.19	12.85	1.10	0.58	35.08	20.97	1.33
700	22.42	26.85	17.30	13.08	1.10	0.58	36.17	21.01	1.27
800	22.41	26.80	17.53	13.40	1.10	0.58	36.16	21.03	1.20
900	22.38	26.78	17.88	13.80	1.10	0.59	36.30	21.01	1.16
1000	22.35	26.75	18.32	14.25	1.11	0.59	36.35	21.03	1.17
1200	22.27	26.70	19.33	15.29	1.11	0.61	36.11	20.96	1.17
1400	22.17	26.66	20.27	16.49	1.12	0.62	35.76	20.87	1.21
1600	22.05	26.63	21.10	17.79	1.13	0.64	35.39	20.79	1.27
1800	21.91	26.61	21.76	18.97	1.13	0.66	35.17	20.69	1.29
2000	21.76	26.59	21.94	19.94	1.14	0.67	34.98	20.67	1.33
2200	21.60	26.59	21.62	20.62	1.15	0.69	34.89	20.52	1.31
2400	21.42	26.62	21.18	20.56	1.16	0.71	34.93	20.28	1.30
2600	21.23	26.63	20.53	19.66	1.17	0.72	34.51	20.06	1.38
2800	21.04	26.66	19.34	18.41	1.18	0.73	34.03	19.78	1.44
3000	20.82	26.69	17.72	16.88	1.19	0.75	33.75	19.44	1.45
3200	20.60	26.74	16.12	15.21	1.20	0.75	33.41	19.34	1.51
3400	20.36	26.83	14.72	13.65	1.22	0.76	33.00	19.32	1.51
3600	20.11	26.93	13.44	12.31	1.23	0.76	32.81	19.38	1.54
3800	19.85	27.06	12.33	11.19	1.25	0.76	32.45	19.40	1.53
4000	19.57	27.22	11.47	10.23	1.27	0.76	32.23	19.58	1.58
4200	19.33	27.34	10.90	9.45	1.29	0.75	31.90	19.56	1.66
4400	19.11	27.42	10.58	8.88	1.30	0.74	31.43	19.53	1.61
4800	18.67	27.66	10.49	8.08	1.35	0.73	30.79	19.21	1.66
5000	18.45	27.81	10.66	7.76	1.38	0.72	30.46	18.92	1.71
5200	18.20	28.06	11.03	7.49	1.43	0.72	29.95	18.37	1.73
5400	17.90	28.42	11.46	7.20	1.50	0.73	29.69	17.79	1.84
5600	17.57	28.91	12.01	7.02	1.59	0.74	29.36	17.21	1.87
5800	17.37	29.20	13.24	6.93	1.65	0.75	29.02	16.79	1.98
6000	17.16	29.32	14.09	6.54	1.67	0.73	28.67	16.73	2.14

Typical Performance Data

Full 2-Port Extension

Definitions:

Input Return Loss = -S11 (dB)

Gain(Power Gain) = S21 (dB)

Reverse Isolation = -S12 (dB)

Output Return Loss = -S22 (dB)

TEST CONDITIONS: Vd = 4.75V, Ve = 5V, Id = 81mA @Temperature = +25°C

FREQ.	Gain	Isolation	Input Return Loss	Output Return Loss	Stability		IP-3 Output	1dB Comp. Output	Noise Figure
					K	Measure			
(MHz)	(dB)	(dB)	(dB)	(dB)	K	Measure	(dBm)	(dBm)	(dB)
200	18.60	31.13	7.88	7.85	1.69	0.87	30.91	18.44	1.95
300	21.71	27.81	12.86	11.15	1.16	0.69	31.86	19.79	1.52
400	22.24	27.16	16.00	12.37	1.12	0.62	32.73	20.32	1.43
500	22.36	26.95	17.07	12.59	1.10	0.59	33.98	20.50	1.37
600	22.39	26.86	17.26	12.74	1.10	0.58	34.88	20.56	1.33
700	22.39	26.80	17.36	12.97	1.10	0.58	35.67	20.60	1.26
800	22.38	26.75	17.58	13.29	1.10	0.58	35.83	20.64	1.20
900	22.35	26.72	17.92	13.69	1.10	0.58	36.10	20.66	1.15
1000	22.32	26.68	18.33	14.14	1.10	0.59	36.04	20.66	1.15
1200	22.23	26.63	19.28	15.18	1.11	0.60	36.12	20.61	1.15
1400	22.13	26.61	20.11	16.39	1.12	0.62	36.10	20.55	1.20
1600	22.01	26.59	20.82	17.66	1.12	0.64	35.72	20.47	1.25
1800	21.87	26.56	21.36	18.80	1.13	0.65	35.32	20.40	1.27
2000	21.72	26.54	21.47	19.74	1.14	0.67	35.24	20.36	1.28
2200	21.55	26.55	21.12	20.36	1.15	0.69	35.00	20.23	1.30
2400	21.37	26.57	20.71	20.26	1.16	0.71	34.96	19.96	1.29
2600	21.19	26.57	20.14	19.36	1.17	0.72	35.13	19.72	1.37
2800	20.98	26.61	19.04	18.13	1.18	0.73	34.85	19.47	1.41
3000	20.77	26.66	17.52	16.64	1.19	0.75	34.58	19.15	1.45
3200	20.54	26.73	16.02	15.02	1.20	0.76	34.34	19.05	1.48
3400	20.30	26.81	14.68	13.48	1.22	0.76	33.91	19.03	1.51
3600	20.05	26.91	13.45	12.17	1.23	0.76	33.60	19.09	1.51
3800	19.79	27.03	12.36	11.08	1.25	0.76	32.62	19.12	1.53
4000	19.51	27.17	11.52	10.13	1.27	0.76	32.40	19.34	1.58
4200	19.27	27.30	10.98	9.35	1.28	0.75	32.10	19.28	1.64
4400	19.06	27.41	10.68	8.79	1.30	0.74	31.79	19.26	1.58
4800	18.61	27.61	10.63	7.99	1.35	0.72	30.98	19.00	1.63
5000	18.39	27.75	10.81	7.67	1.38	0.72	30.49	18.76	1.69
5200	18.14	27.99	11.20	7.39	1.43	0.72	30.10	18.31	1.70
5400	17.84	28.35	11.65	7.11	1.49	0.72	29.73	17.76	1.82
5600	17.50	28.86	12.20	6.92	1.58	0.74	29.25	17.14	1.84
5800	17.31	29.16	13.41	6.83	1.64	0.75	28.78	16.69	1.97
6000	17.09	29.30	14.24	6.45	1.67	0.73	28.36	16.64	2.16

Typical Performance Data

Full 2-Port Extension

Definitions:

Input Return Loss = -S11 (dB)

Gain(Power Gain) = S21 (dB)

Reverse Isolation = -S12 (dB)

Output Return Loss = -S22 (dB)

TEST CONDITIONS: Vd = 5.25V, Ve = 5V, Id = 83mA @Temperature = +25°C

FREQ.	Gain	Isolation	Input Return Loss	Output Return Loss	Stability		IP-3 Output	1dB Comp. Output	Noise Figure
					K	Measure			
(MHz)	(dB)	(dB)	(dB)	(dB)	K	Measure	(dBm)	(dBm)	(dB)
200	18.61	31.24	7.90	8.18	1.73	0.89	30.69	19.59	2.00
300	21.71	27.93	12.88	11.52	1.18	0.71	31.49	20.77	1.55
400	22.24	27.30	15.96	12.75	1.13	0.63	32.63	21.13	1.45
500	22.36	27.11	16.95	12.97	1.12	0.61	33.44	21.25	1.40
600	22.39	27.02	17.10	13.12	1.11	0.60	34.36	21.29	1.35
700	22.39	26.96	17.20	13.35	1.11	0.59	35.61	21.31	1.28
800	22.38	26.92	17.44	13.68	1.11	0.60	35.75	21.33	1.22
900	22.35	26.88	17.81	14.08	1.11	0.60	35.70	21.34	1.18
1000	22.32	26.85	18.27	14.54	1.12	0.61	35.88	21.34	1.18
1200	22.24	26.80	19.35	15.60	1.12	0.62	35.82	21.29	1.19
1400	22.14	26.76	20.41	16.83	1.13	0.63	35.66	21.20	1.23
1600	22.03	26.73	21.39	18.16	1.13	0.65	35.70	21.10	1.28
1800	21.90	26.71	22.20	19.37	1.14	0.66	35.31	21.02	1.31
2000	21.75	26.70	22.51	20.40	1.15	0.68	35.13	20.96	1.32
2200	21.59	26.69	22.22	21.14	1.16	0.69	34.86	20.82	1.32
2400	21.42	26.67	21.76	21.11	1.17	0.71	34.86	20.55	1.31
2600	21.23	26.70	21.01	20.18	1.18	0.72	34.49	20.34	1.40
2800	21.04	26.75	19.68	18.85	1.19	0.74	34.36	20.03	1.45
3000	20.83	26.80	17.94	17.25	1.20	0.75	33.96	19.72	1.48
3200	20.60	26.85	16.25	15.51	1.22	0.76	33.59	19.58	1.53
3400	20.37	26.92	14.77	13.89	1.23	0.76	33.17	19.56	1.53
3600	20.12	27.02	13.45	12.52	1.24	0.77	32.80	19.62	1.55
3800	19.86	27.13	12.31	11.38	1.26	0.77	32.40	19.64	1.57
4000	19.58	27.29	11.42	10.40	1.28	0.76	32.25	19.83	1.62
4200	19.34	27.41	10.83	9.61	1.30	0.76	31.97	19.78	1.67
4400	19.12	27.52	10.50	9.04	1.32	0.75	31.61	19.74	1.64
4800	18.67	27.75	10.37	8.25	1.37	0.74	31.05	19.37	1.67
5000	18.45	27.91	10.52	7.94	1.40	0.73	30.62	19.04	1.73
5200	18.20	28.17	10.87	7.67	1.45	0.73	30.13	18.47	1.74
5400	17.90	28.52	11.30	7.38	1.52	0.74	29.63	17.87	1.85
5600	17.57	29.02	11.87	7.20	1.62	0.75	29.34	17.29	1.89
5800	17.38	29.33	13.13	7.11	1.68	0.76	29.01	16.85	2.01
6000	17.17	29.43	14.00	6.71	1.70	0.74	28.69	16.80	2.15

Typical Performance Data

Without Full 2-Port Extension

Definitions:

Input Return Loss = -S11 (dB)

Gain(Power Gain) = S21 (dB)

Reverse Isolation = -S12 (dB)

Output Return Loss = -S22 (dB)

TEST CONDITIONS: Vd = 5.00V, Ve = 5V, Id = 82mA @Temperature = +25°C

FREQ.	Gain	Isolation	Input Return Loss	Output Return Loss	Stability		IP-3 Output	1dB Comp. Output	Noise Figure
					K	Measure			
(MHz)	(dB)	(dB)	(dB)	(dB)	K	Measure	(dBm)	(dBm)	(dB)
200	18.69	31.16	7.87	7.88	1.69	0.87	30.78	19.06	1.96
300	21.79	27.83	12.84	11.19	1.16	0.69	32.18	20.31	1.53
400	22.31	27.19	15.93	12.40	1.11	0.61	33.06	20.76	1.44
500	22.43	26.98	16.93	12.61	1.10	0.58	34.01	20.90	1.38
600	22.46	26.89	17.09	12.75	1.10	0.57	35.08	20.97	1.33
700	22.45	26.84	17.19	12.98	1.10	0.57	36.17	21.01	1.27
800	22.43	26.79	17.42	13.30	1.10	0.58	36.16	21.03	1.20
900	22.41	26.76	17.77	13.71	1.10	0.58	36.30	21.01	1.16
1000	22.37	26.73	18.21	14.16	1.10	0.59	36.35	21.03	1.17
1200	22.28	26.69	19.24	15.20	1.11	0.60	36.11	20.96	1.17
1400	22.18	26.66	20.21	16.40	1.12	0.62	35.76	20.87	1.21
1600	22.05	26.64	21.08	17.68	1.13	0.64	35.39	20.79	1.27
1800	21.92	26.63	21.79	18.85	1.13	0.66	35.17	20.69	1.29
2000	21.76	26.61	22.02	19.84	1.14	0.67	34.98	20.67	1.33
2200	21.59	26.61	21.75	20.53	1.15	0.69	34.89	20.52	1.31
2400	21.41	26.62	21.35	20.52	1.16	0.71	34.93	20.28	1.30
2600	21.22	26.65	20.72	19.68	1.17	0.72	34.51	20.06	1.38
2800	21.02	26.66	19.51	18.46	1.18	0.73	34.03	19.78	1.44
3000	20.80	26.73	17.87	16.96	1.20	0.75	33.75	19.44	1.45
3200	20.57	26.80	16.27	15.30	1.21	0.76	33.41	19.34	1.51
3400	20.33	26.87	14.84	13.74	1.22	0.76	33.00	19.32	1.51
3600	20.08	26.98	13.55	12.41	1.24	0.77	32.81	19.38	1.54
3800	19.81	27.11	12.43	11.29	1.26	0.77	32.45	19.40	1.53
4000	19.54	27.26	11.56	10.32	1.28	0.76	32.23	19.58	1.58
4200	19.29	27.39	10.98	9.54	1.30	0.76	31.90	19.56	1.66
4400	19.07	27.48	10.67	8.98	1.32	0.75	31.43	19.53	1.61
4800	18.62	27.72	10.58	8.18	1.37	0.74	30.79	19.21	1.66
5000	18.39	27.87	10.75	7.87	1.40	0.73	30.46	18.92	1.71
5200	18.14	28.12	11.12	7.59	1.45	0.73	29.95	18.37	1.73
5400	17.84	28.48	11.56	7.31	1.52	0.74	29.69	17.79	1.84
5600	17.50	28.98	12.12	7.13	1.62	0.75	29.36	17.21	1.87
5800	17.31	29.29	13.37	7.04	1.68	0.76	29.02	16.79	1.98
6000	17.09	29.41	14.23	6.65	1.71	0.74	28.67	16.73	2.14

Typical Performance Data

Without Full 2-Port Extension

Definitions:

Input Return Loss = -S11 (dB)

Gain(Power Gain) = S21 (dB)

Reverse Isolation = -S12 (dB)

Output Return Loss = -S22 (dB)

TEST CONDITIONS: Vd = 4.75V, Ve = 5V, Id = 81mA @Temperature = +25°C

FREQ.	Gain	Isolation	Input Return Loss	Output Return Loss	Stability		IP-3 Output	1dB Comp. Output	Noise Figure
					K	Measure			
(MHz)	(dB)	(dB)	(dB)	(dB)	K	Measure	(dBm)	(dBm)	(dB)
200	18.66	31.05	7.85	7.81	1.67	0.87	30.91	18.44	1.95
300	21.76	27.74	12.82	11.10	1.15	0.68	31.86	19.79	1.52
400	22.28	27.10	15.92	12.31	1.11	0.61	32.73	20.32	1.43
500	22.40	26.91	16.95	12.53	1.10	0.58	33.98	20.50	1.37
600	22.43	26.81	17.11	12.68	1.10	0.57	34.88	20.56	1.33
700	22.43	26.76	17.21	12.91	1.10	0.57	35.67	20.60	1.26
800	22.41	26.72	17.43	13.23	1.10	0.57	35.83	20.64	1.20
900	22.38	26.69	17.77	13.64	1.10	0.58	36.10	20.66	1.15
1000	22.34	26.65	18.19	14.09	1.10	0.58	36.04	20.66	1.15
1200	22.25	26.61	19.15	15.13	1.11	0.60	36.12	20.61	1.15
1400	22.15	26.60	20.04	16.33	1.11	0.62	36.10	20.55	1.20
1600	22.02	26.57	20.81	17.60	1.12	0.64	35.72	20.47	1.25
1800	21.88	26.57	21.41	18.74	1.13	0.65	35.32	20.40	1.27
2000	21.72	26.56	21.59	19.68	1.14	0.67	35.24	20.36	1.28
2200	21.55	26.56	21.30	20.32	1.15	0.69	35.00	20.23	1.30
2400	21.37	26.57	20.95	20.25	1.16	0.71	34.96	19.96	1.29
2600	21.18	26.60	20.39	19.37	1.17	0.72	35.13	19.72	1.37
2800	20.97	26.64	19.28	18.17	1.18	0.74	34.85	19.47	1.41
3000	20.75	26.68	17.74	16.70	1.19	0.75	34.58	19.15	1.45
3200	20.52	26.77	16.22	15.09	1.21	0.76	34.34	19.05	1.48
3400	20.28	26.84	14.85	13.56	1.22	0.76	33.91	19.03	1.51
3600	20.02	26.94	13.59	12.26	1.24	0.77	33.60	19.09	1.51
3800	19.76	27.05	12.49	11.16	1.25	0.76	32.62	19.12	1.53
4000	19.48	27.22	11.64	10.21	1.28	0.76	32.40	19.34	1.58
4200	19.24	27.34	11.09	9.44	1.30	0.75	32.10	19.28	1.64
4400	19.02	27.45	10.79	8.88	1.32	0.74	31.79	19.26	1.58
4800	18.57	27.67	10.73	8.09	1.37	0.73	30.98	19.00	1.63
5000	18.34	27.82	10.92	7.77	1.40	0.73	30.49	18.76	1.69
5200	18.09	28.06	11.31	7.49	1.45	0.73	30.10	18.31	1.70
5400	17.78	28.41	11.76	7.21	1.51	0.73	29.73	17.76	1.82
5600	17.44	28.92	12.32	7.03	1.61	0.74	29.25	17.14	1.84
5800	17.25	29.25	13.56	6.94	1.68	0.75	28.78	16.69	1.97
6000	17.02	29.36	14.42	6.56	1.70	0.74	28.36	16.64	2.16

Typical Performance Data

Without Full 2-Port Extension

Definitions:

Input Return Loss = -S11 (dB)

Gain(Power Gain) = S21 (dB)

Reverse Isolation = -S12 (dB)

Output Return Loss = -S22 (dB)

TEST CONDITIONS: Vd = 5.25V, Ve = 5V, Id = 83mA @Temperature = +25°C

FREQ.	Gain	Isolation	Input Return Loss	Output Return Loss	Stability		IP-3 Output	1dB Comp. Output	Noise Figure
					K	Measure			
(MHz)	(dB)	(dB)	(dB)	(dB)	K	Measure	(dBm)	(dBm)	(dB)
200	18.66	31.19	7.86	8.11	1.71	0.88	30.69	19.59	2.00
300	21.76	27.92	12.82	11.47	1.17	0.70	31.49	20.77	1.55
400	22.28	27.28	15.89	12.70	1.12	0.63	32.63	21.13	1.45
500	22.40	27.07	16.88	12.92	1.11	0.60	33.44	21.25	1.40
600	22.43	26.98	17.02	13.06	1.11	0.59	34.36	21.29	1.35
700	22.42	26.93	17.13	13.30	1.11	0.59	35.61	21.31	1.28
800	22.40	26.90	17.37	13.63	1.11	0.59	35.75	21.33	1.22
900	22.38	26.87	17.74	14.04	1.11	0.60	35.70	21.34	1.18
1000	22.34	26.84	18.20	14.50	1.11	0.60	35.88	21.34	1.18
1200	22.26	26.79	19.29	15.56	1.12	0.62	35.82	21.29	1.19
1400	22.15	26.76	20.37	16.78	1.13	0.63	35.66	21.20	1.23
1600	22.03	26.72	21.38	18.11	1.13	0.65	35.70	21.10	1.28
1800	21.90	26.70	22.21	19.32	1.14	0.66	35.31	21.02	1.31
2000	21.75	26.70	22.54	20.37	1.15	0.68	35.13	20.96	1.32
2200	21.58	26.70	22.28	21.12	1.16	0.70	34.86	20.82	1.32
2400	21.40	26.70	21.83	21.11	1.17	0.71	34.86	20.55	1.31
2600	21.22	26.74	21.12	20.20	1.18	0.73	34.49	20.34	1.40
2800	21.02	26.76	19.79	18.90	1.20	0.74	34.36	20.03	1.45
3000	20.80	26.82	18.03	17.31	1.21	0.75	33.96	19.72	1.48
3200	20.58	26.88	16.33	15.58	1.22	0.76	33.59	19.58	1.53
3400	20.34	26.96	14.85	13.96	1.23	0.77	33.17	19.56	1.53
3600	20.08	27.05	13.52	12.59	1.25	0.77	32.80	19.62	1.55
3800	19.82	27.17	12.38	11.46	1.27	0.77	32.40	19.64	1.57
4000	19.54	27.34	11.49	10.48	1.29	0.77	32.25	19.83	1.62
4200	19.29	27.45	10.90	9.69	1.31	0.76	31.97	19.78	1.67
4400	19.07	27.58	10.57	9.12	1.33	0.76	31.61	19.74	1.64
4800	18.62	27.83	10.44	8.34	1.39	0.75	31.05	19.37	1.67
5000	18.39	27.98	10.60	8.03	1.42	0.74	30.62	19.04	1.73
5200	18.14	28.24	10.95	7.76	1.47	0.74	30.13	18.47	1.74
5400	17.83	28.59	11.39	7.48	1.55	0.75	29.63	17.87	1.85
5600	17.50	29.11	11.95	7.30	1.65	0.76	29.34	17.29	1.89
5800	17.31	29.41	13.23	7.21	1.72	0.77	29.01	16.85	2.01
6000	17.09	29.54	14.10	6.81	1.74	0.75	28.69	16.80	2.15

Typical Performance Curves

Full 2-Port Extension

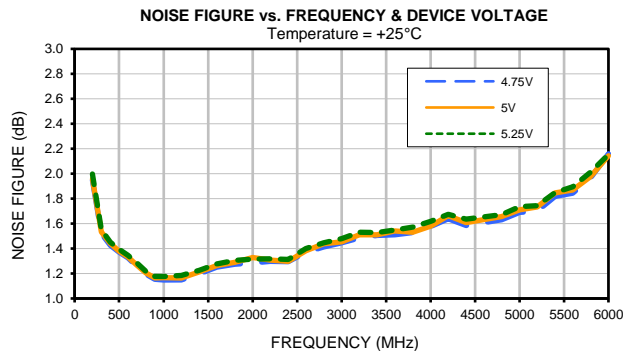
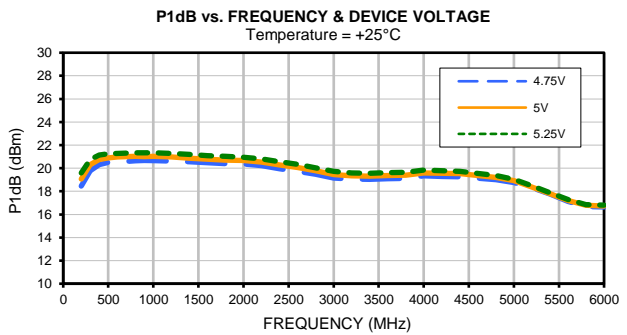
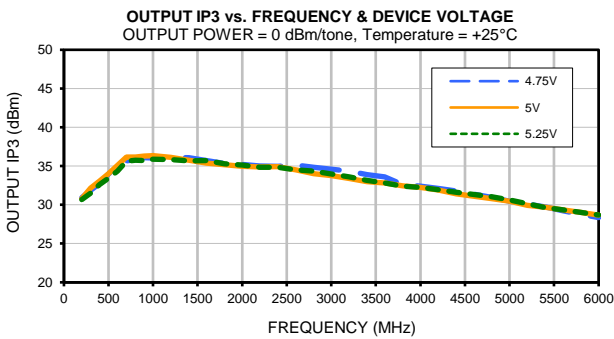
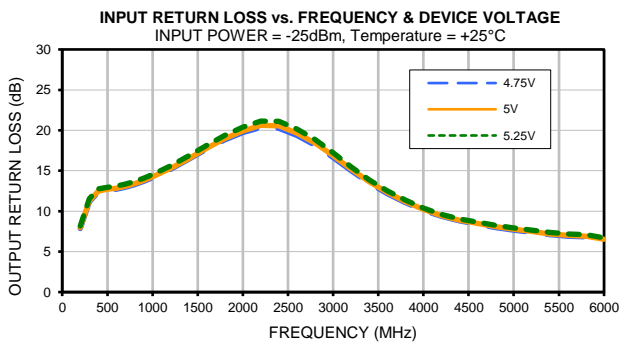
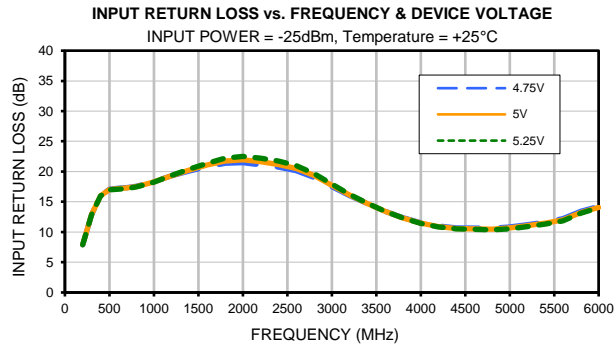
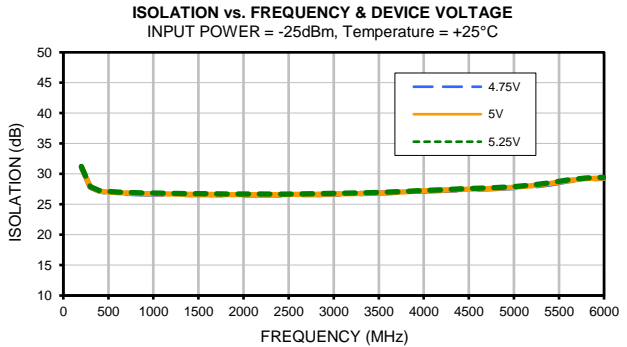
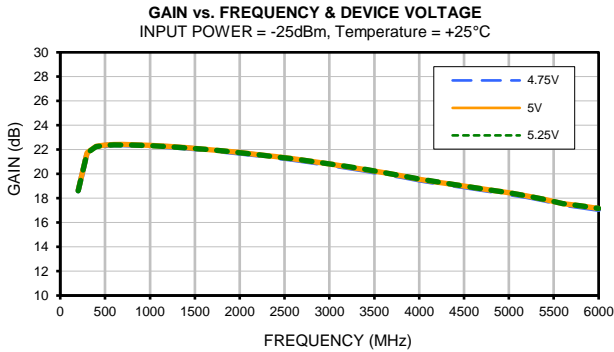

Typical Performance Curves

Without Full 2-Port Extension

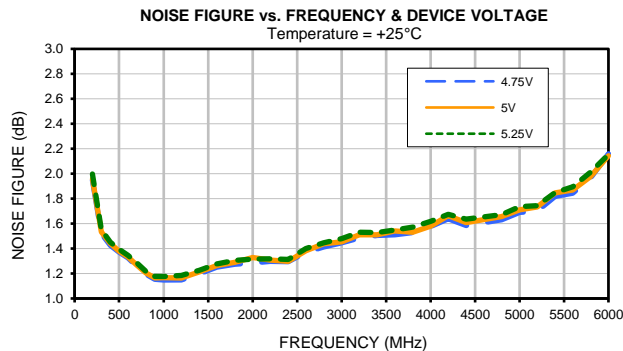
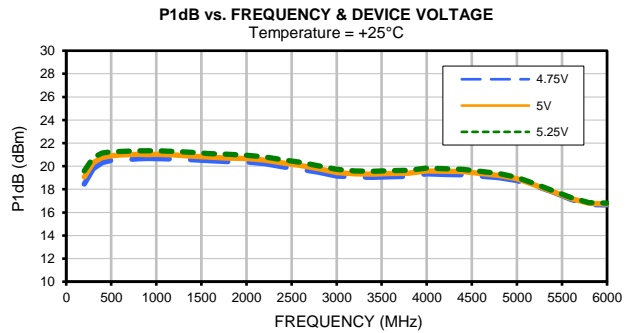
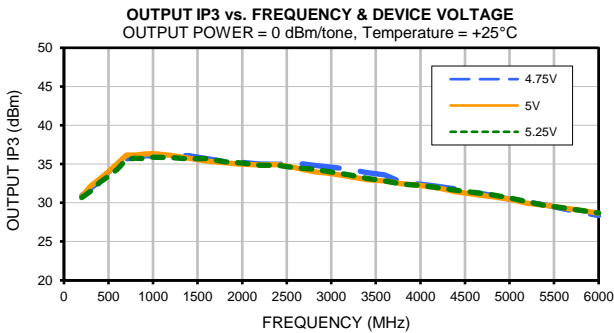
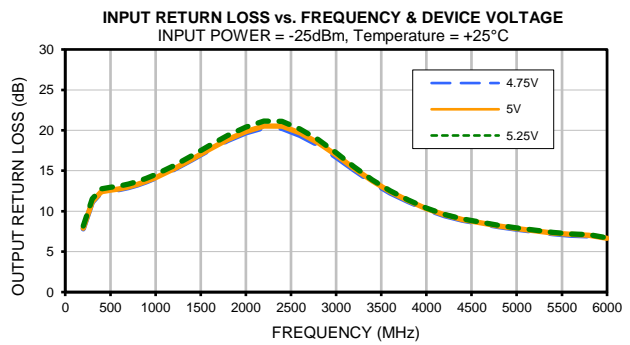
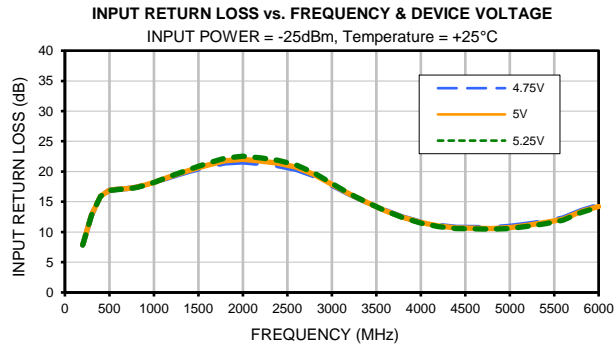
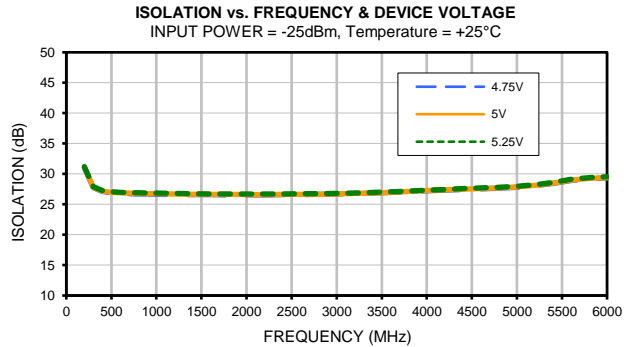
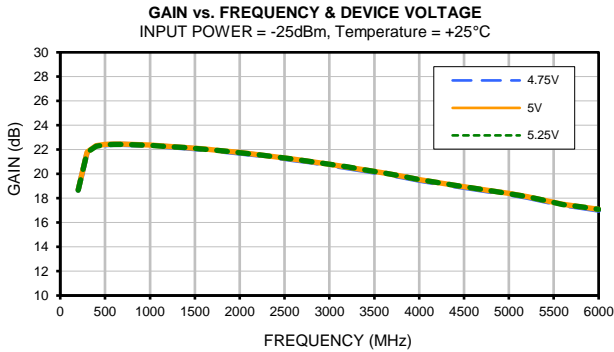

Evaluation Board and Circuit

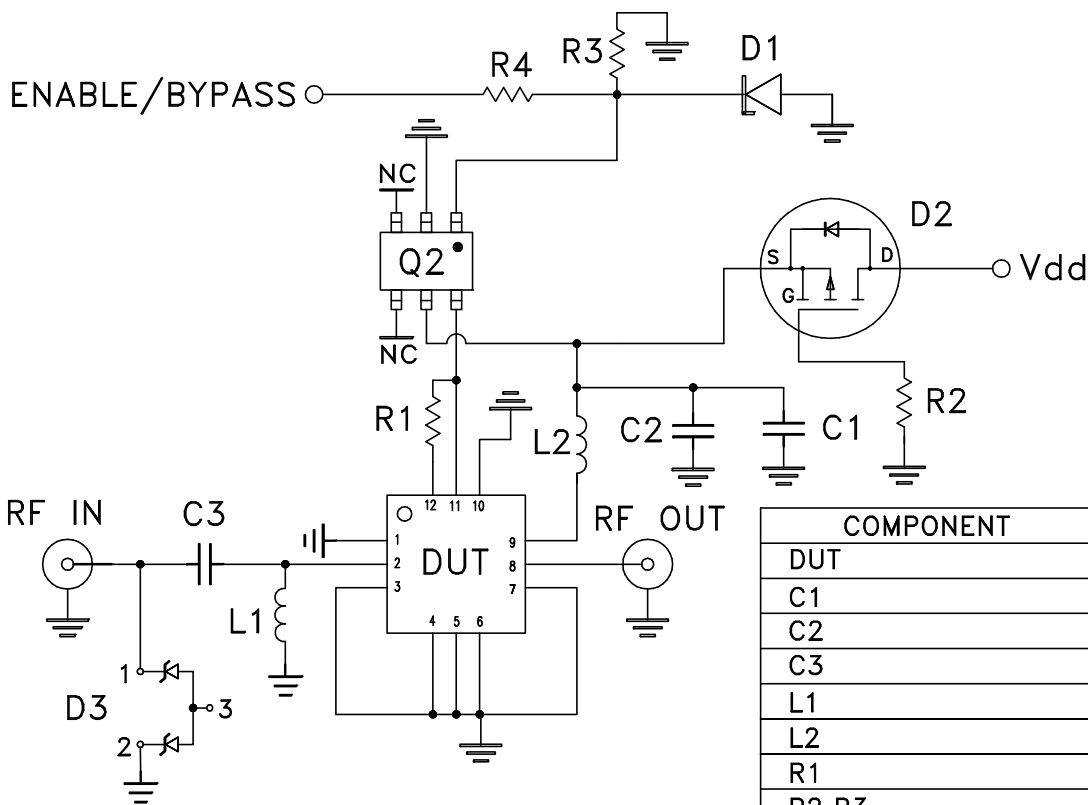
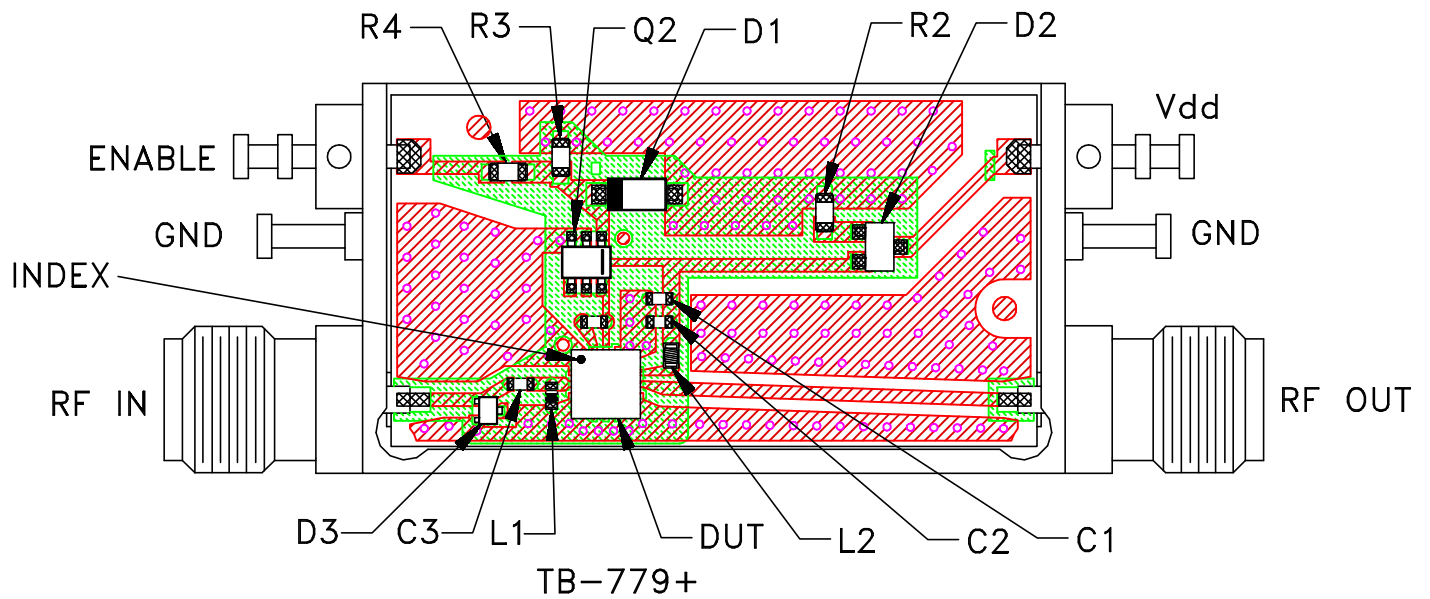

Schematic Diagram

COMPONENT		VALUE	SIZE
DUT		TSS-53LNB+	
C1		.1 uF	0402
C2		10 pF	
C3		.001 uF	
L1		47 nH	
L2		56 nH	
R1		3.92 kOhm	0603
R2,R3		10 kOhm	
R4		1 kOhm	
D1	MCL	B40-28-5230B+	
	ON SEMI	MMSZ5230BT1G	
D2	MCL	B43-4101PT1+	
	ON SEMI	NTS4101PT1G	
D3	MCL	B40-ESD7L5+	
	ON SEMI	ESD7L5.0DT5G	
Q2	MCL	B49-SN74-17+	
	TEXAS INSTRUMENT	SN74LVC2G17DCKR	

Notes:

- 50 Ohm SMA Female connectors.
- PCB Material: R04350 or equivalent, Dielectric Constant=3.5, Thickness=.010 inch.

Mini-Circuits®

All Mini-Circuits products are manufactured under exacting quality assurance and control standards, and are capable of meeting published specifications after being subjected to any or all of the following physical and environmental test.

Specification	Test/Inspection Condition	Reference/Spec
Operating Temperature	-40° to 85° C or -40° to 105° C or -55° to 105° C or -45° to 105° C Ambient Environment	Refer to Individual Model Data Sheet
Storage Environment (Die)	-65° to 150°C	Individual Model Data Sheet
Storage Environment(Packaging)	-40° to 70°C and 40 to 60% humidity (In Factory Shipped Package)	