

Low Noise, Wideband, Shutdown Monolithic Amplifier Die

TSS-44-D+

50Ω 22 to 43.5 GHz

The Big Deal

- 22 to 43.5 GHz for 5G Applications
- Excellent Gain flatness, ± 0.9 dB typ. over 22-40 GHz
- Shutdown feature

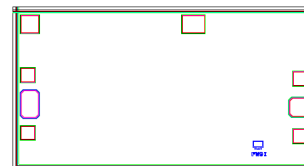

Product Overview

The TSS-44-D+ is a MMIC amplifier die with shutdown feature fabricated using E-PHEMT technology and is a fully integrated 3-stage gain block up to 43.5 GHz with excellent active directivity. The TSS-44-D+ integrates the entire matching network with the majority of the bias circuit into the design, reducing the need for complicated external circuits. This approach makes the TSS-44-D+ extremely flexible and enables simple, straightforward use.

Key Features

Feature	Advantages
Wideband, 22 to 43.5 GHz	The broad frequency range supports a wide array of requirements including telecommunications applications such as 5G and microwave radio backhaul, broadband commercial test and measurement systems, radar and commercial satellite applications
Excellent Gain Flatness	Typical ± 0.9 dB gain flatness across the entire frequency range minimizes the need for external equalizer networks making it a great fit for instrumentation and other broadband applications
High Directivity	With active directivity of 28 dB, the TSS-44-D+ is an excellent choice for buffering broadband circuits. eliminating the need for an expensive isolator in most cases.
Shutdown feature	Allow users to turn on and off the amplifier with pulsed signals while keeping the power supply at constant voltage.
Integrated DC Blocks & Bias-Tee	Saves motherboard space and minimizes overall cost. Very user friendly.
Unpackaged die	Enables user to integrate it directly into hybrids.



Wideband, Microwave, Shutdown Monolithic Amplifier Die

TSS-44-D+

50Ω 22 to 43.5 GHz

Product Features

- Super high frequency and wideband, 22 to 43.5 GHz
- Gain, 17.6 dB typ. & Flatness, ±0.9 dB to 40 GHz
- Excellent active directivity, 28 dB typ.
- Positive Supply Voltage, 4V, 22mA
- Integrated DC blocks, Bias-Tee & Microwave bypass capacitor
- Unconditionally Stable

Typical Applications

- 5G
- Radio Navigation
- Mobile
- Fixed satellite
- Space research

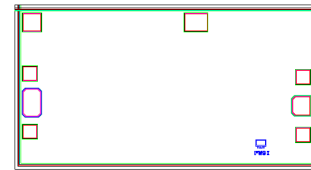

+RoHS Compliant
The +Suffix identifies RoHS Compliance. See our web site for RoHS Compliance methodologies and qualifications

Ordering Information: Refer to Last Page

General Description

The TSS-44-D+ is a MMIC amplifier die with shutdown feature fabricated using E-PHEMT technology and is a fully integrated 3-stage gain block up to 43.5 GHz with excellent active directivity. The TSS-44-D+ integrates the entire matching network with the majority of the bias circuit into the design, reducing the need for complicated external circuits. This approach makes the TSS-44-D+ extremely flexible and enables simple, straightforward use.

Simplified Schematic and Pad description

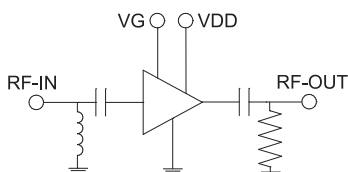

Pad#	Function
1	RF-IN
2,5,7,8	Ground
3	Vg
4	Vd
6	RF-OUT

Bonding Pad Position

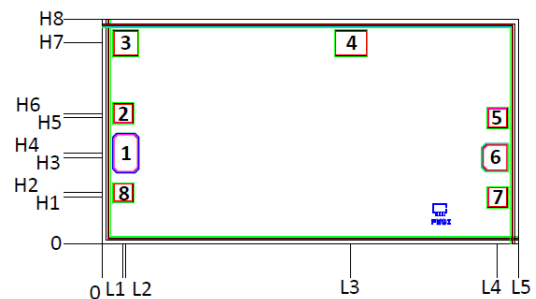

Dimensions in μm, Typical

L1	L2	L3	L4	L5	H1	H2	H3	H4	H5	H6	H7	H8
79	89	944	1500	1580	178	195	328	345	478	495	761	850
Thickness		Die size	Pad size 1	Pad size 2,5,7	Pad size 3	Pad size 4	Pad size 6	Pad size 8				
100		1580 x 850	101x151	81x81	101x101	126x101	101x106	81x76				

Electrical Specifications⁽¹⁾ at 25°C, $Z_0=50\Omega$, and $V_{DD}=4V$ unless otherwise noted.

Parameter	Condition (GHz)	Amplifier-ON			Amplifier-OFF	Units
		Min.	Typ.	Max.	Typ.	
Frequency Range		22		43.5	22-43.5	GHz
Noise Figure	22		3.7		—	dB
	25		3.3		—	
	30		3.2		—	
	35		3.3		—	
	40		3.5		—	
Gain	22		15.8		-41	dB
	25		16.8		-33	
	30		17.6		-29	
	35		17.7		-30	
	40		15.7		-27	
Gain Flatness	22-40		0.9		—	dB
	22-43.5		28		—	dB
Input Return Loss	22		10		3	dB
	25		17		6	
	30		16		5	
	35		12		3	
	40		9		5	
Output Return Loss	22		13		9	dB
	25		14		8	
	30		18		9	
	35		9		7	
	40		7		4	
Output Power @ 1dB compression AMP-ON	22		1.2		—	dBm
	25		1.8		—	
	30		4.1		—	
	35		6.4		—	
	40		7.8		—	
Output IP3 ($P_{out}=-10dBm/$ tone)	22		10.1		—	dBm
	25		10.1		—	
	30		12.7		—	
	35		16.7		—	
	40		15.5		—	
Device Operating Voltage (V_{DD})		3.8	4.0	4.2	4.0	V
		—	22	36	3	mA
Control Voltage (V_G)		3.8	4.0	4.2	0	V
Control Current (I_G)			8		2	mA
DC Current (I_d) Variation Vs. Temperature ²			-15		—	$\mu A/^\circ C$
DC Current (I_d) Variation Vs. Voltage			0.006		—	mA/mV
Thermal Resistance			51.9		—	$^\circ C/W$

1. Measured on Mini-Circuits Characterization test board. Die is packaged in 3X3 mm, 12-lead MCL package and soldered on TB-TSS-44+. See Characterization Test Circuit (Fig. 1)

2. (Current at 85°C - Current at -45°C)/130

Absolute Maximum Ratings^{1,3}

Parameter	Ratings
Operating Temperature (ground lead)	-40°C to 85°C
Total Power Dissipation	0.94W
Input Power	19dBm (5 min. max), 8dBm (continuous)
DC Voltage V_{DD} ⁴ (Pad 11)	6V
DC Voltage V_G ⁵ (Pad 12)	5V

³ Permanent damage may occur if these limits are exceeded.

⁴ Measured by keeping $V_G=4V$.

⁵ Measured by keeping $V_{DD}=4V$.

Control Voltage (V_G) Fig. 1

	Min.	Typ.	Max.	Units
Amplifier-ON	3.8	4	4.2	V
Amplifier-OFF	—	0	0.2	V

Switching Specifications (Rise/Fall Time)

Parameter		Min.	Typ.	Max.	Units
Amplifier ON to Shutdown	OFF TIME (50% Control to 10% RF)	—	9.8	—	μs
	FALL TIME (90 to 10% RF)	—	9.2	—	
Amplifier Shutdown to ON	ON TIME (50% Control to 90% RF)	—	11.2	—	μs
	RISE TIME (10% to 90% RF)	—	10.7	—	
Control Voltage Leakage		—	2.0	—	mV

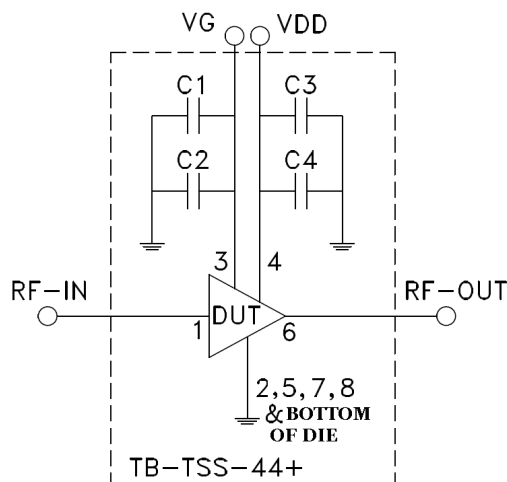
Characterization Test Circuit / Recommended Application Circuit

Component	Size	Value	Part Number	Manufacturer
C1, C3	0402	0.1 uF	GRM155R71C104KA88D	Murata
C2, C4	0402	100pF	GRM155C1H101JA01J	Murata

Fig 1. Block diagram of Test Circuit used for characterization. (Die is packaged in 3x3mm, 12-lead MCLP and soldered on Mini-Circuits Characterization test board TB-TSS-44+) Gain, Return loss, Output power at 1dB compression (P1dB) , output IP3 (OIP3) and noise figure measured using Agilent's N5244A PNA-X microwave network analyzer.

Conditions:

- Gain and Return loss: Pin= -25dBm
- Output IP3 (OIP3): Two tones, spaced 1 MHz apart, -10dBm/tone at output.
- Switching Time:

RF Signal: Pin=-25dBm, $f_{RF}=22\text{GHz}$

$V_{DD}=4\text{VDC}$, VG= Pulse Signal at 1kHz with $V_{high}=4\text{V}$, $V_{low}=0\text{V}$ & 50% duty cycle

Assembly Diagram

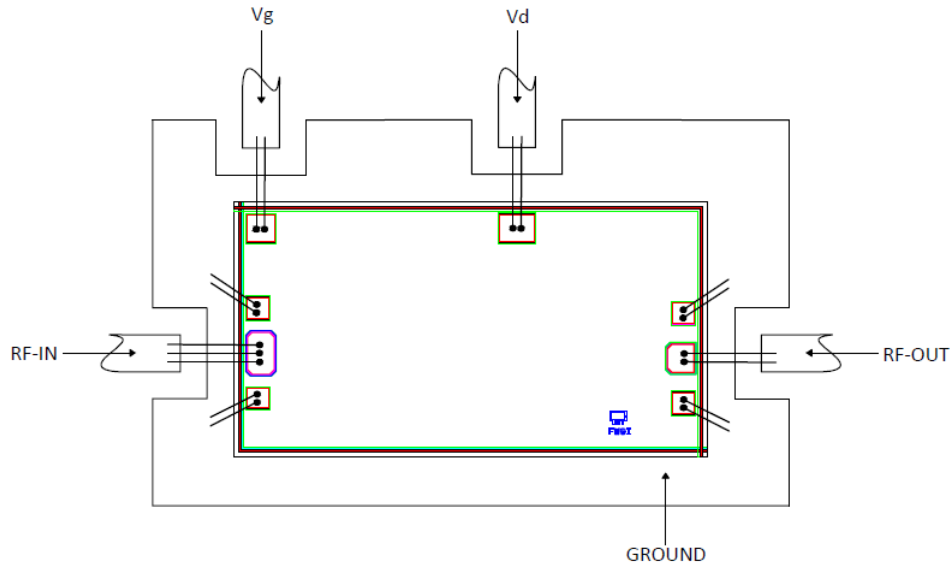

Assembly and Handling Procedure

1. Storage
Dice should be stored in a dry nitrogen purged desiccators or equivalent.
2. ESD
MMIC E-PHEMT amplifier dice are susceptible to electrostatic and mechanical damage. Dice are supplied in antistatic protected material, which should be opened in clean room conditions at an appropriately grounded anti-static workstation. Devices need careful handling using correctly designed collets, vacuum pickup tips or sharp antistatic tweezers to deter ESD damage to dice.
3. Die Attach
The die mounting surface must be clean and flat. Using conductive silver filled epoxy, recommended epoxies are DieMat DM6030HK-PT/H579 or Ablestik 84-1LMISR4. Apply sufficient epoxy to meet required epoxy bond line thickness, epoxy fillet height and epoxy coverage around total die periphery. Parts shall be cured in a nitrogen filled atmosphere per manufacturer's cure condition. It is recommended to use antistatic die pick up tools only.
4. Wire Bonding
Bond pad openings in the surface passivation above the bond pads are provided to allow wire bonding to the dice gold bond pads. Thermosonic bonding is used with minimized ultrasonic content. Bond force, time, ultrasonic power and temperature are all critical parameters. Suggested wire is pure gold, 1 mil diameter. Bonds must be made from the bond pads on the die to the package or substrate. All bond wires should be kept as short as low as reasonable to minimize performance degradation due to undesirable series inductance.

Additional Detailed Technical Information <i>additional information is available on our dash board.</i>									
Performance Data	Data Table								
	Swept Graphs								
	S-Parameter (S2P Files) Data Set with and without port extension(.zip file)								
Case Style	Die								
Die Ordering and packaging information	<table> <tr> <td>Quantity, Package</td> <td>Model No.</td> </tr> <tr> <td>Small, Gel - Pak: 5,10,50,100 KGD*</td> <td>TSS-44-DG+</td> </tr> <tr> <td>Medium†, Partial wafer: KGD*<1176</td> <td>TSS-44-DP+</td> </tr> <tr> <td>Large†, Full Wafer</td> <td>TSS-44-DF+</td> </tr> </table> <p>†Available upon request contact sales representative</p> <p>Refer to AN-60-067</p>	Quantity, Package	Model No.	Small, Gel - Pak: 5,10,50,100 KGD*	TSS-44-DG+	Medium†, Partial wafer: KGD*<1176	TSS-44-DP+	Large†, Full Wafer	TSS-44-DF+
Quantity, Package	Model No.								
Small, Gel - Pak: 5,10,50,100 KGD*	TSS-44-DG+								
Medium†, Partial wafer: KGD*<1176	TSS-44-DP+								
Large†, Full Wafer	TSS-44-DF+								
Environmental Ratings	ENV80								

*Known Good Dice ("KGD") means that the dice in question have been subjected to Mini-Circuits DC test performance criteria and measurement instructions and that the parametric data of such dice fall within a predefined range. While DC testing is not definitive, it does help to provide a higher degree of confidence that dice are capable of meeting typical RF electrical parameters specified by Mini-Circuits.

ESD Rating**

Human Body Model (HBM): Class 0 (pass 200V) in accordance with ANSI/ESD STM 5.1 - 2001

** Tested in industry standard MCLP 3x3 mm, 12-lead MCLP.

Additional Notes

- Performance and quality attributes and conditions not expressly stated in this specification document are intended to be excluded and do not form a part of this specification document.
- Electrical specifications and performance data contained in this specification document are based on Mini-Circuit's applicable established test performance criteria and measurement instructions.
- The parts covered by this specification document are subject to Mini-Circuits standard limited warranty and terms and conditions (collectively, "Standard Terms"); Purchasers of this part are entitled to the rights and benefits contained therein. For a full statement of the Standard Terms and the exclusive rights and remedies thereunder, please visit Mini-Circuits' website at www.minicircuits.com/MCLStore/terms.jsp
- Mini-Circuits does not warrant the accuracy or completeness of the information, text, graphics and other items contained within this document and same are provided as an accommodation and on an "As is" basis, with all faults.
- Purchasers of this part are solely responsible for proper storing, handling, assembly and processing of Known Good Dice (including, without limitation, proper ESD preventative measures, die preparation, die attach, wire bonding and related assembly and test activities), and Mini-Circuits assumes no responsibility therefor or for environmental effects on Known Good Dice.
- Mini-Circuits and the Mini-Circuits logo are registered trademarks of Scientific Components Corporation d/b/a Mini-Circuits. All other third-party trademarks are the property of their respective owners. A reference to any third-party trademark does not constitute or imply any endorsement, affiliation, sponsorship, or recommendation by any such third-party of Mini-Circuits or its products.



Typical Performance Data

NOTE: Use PDF Bookmarks to view DATA at required conditions

Definitions:

- Input Return Loss = -S11 (dB)
- Gain(Power Gain) = S21 (dB)
- Reverse Isolation = -S12 (dB)
- Output Return Loss = -S22 (dB)

TEST CONDITIONS: Vd = 4.0V, Id = 26mA @ Temperature = +25°C

FREQ	Gain	Isolation	Input Return Loss	Output Return Loss	Stability		IP-3 Output	1dB Comp. Output	Noise Figure
					K	Measure			
(MHz)	(dB)	(dB)	(dB)	(dB)	K	Measure	(dBm)	(dBm)	(dB)
20000	14.41	57.43	4.77	13.43	45.05	1.27	10.43	0.12	4.72
20500	15.18	54.84	5.67	12.45	33.09	1.20	9.98	0.18	4.38
21000	15.84	53.94	6.69	12.13	29.72	1.14	10.28	0.28	4.16
21500	16.34	53.39	7.90	12.15	28.08	1.09	10.31	0.58	3.93
22000	16.68	53.08	9.29	11.94	27.37	1.04	11.42	0.97	3.78
22500	16.90	53.76	10.35	12.17	29.76	1.02	11.48	1.08	3.69
23000	17.08	53.40	11.27	12.27	28.56	1.01	11.71	1.34	3.55
23500	17.25	52.90	12.27	12.79	27.09	1.00	11.34	1.34	3.54
24000	17.43	51.49	13.39	13.04	22.92	0.99	11.24	1.44	3.48
24500	17.62	51.06	14.59	13.01	21.59	0.98	11.95	1.56	3.41
25000	17.81	49.99	16.17	13.47	19.00	0.98	11.65	1.58	3.38
25500	17.94	48.93	18.28	13.90	16.77	0.97	11.31	1.96	3.33
26000	18.04	48.37	18.83	14.75	15.71	0.98	12.03	2.10	3.26
26500	18.10	47.97	18.24	15.43	14.92	0.98	12.61	2.36	3.24
27000	18.17	47.73	17.60	16.06	14.42	0.99	12.84	2.41	3.22
27500	18.29	46.95	17.48	16.52	13.04	0.99	11.58	2.67	3.20
28000	18.44	45.66	17.73	17.54	11.11	1.00	13.24	2.75	3.21
28500	18.52	45.22	18.68	17.84	10.51	0.99	12.75	2.97	3.18
29000	18.54	45.71	18.50	17.55	11.07	0.99	13.27	3.27	3.18
29500	18.53	45.33	17.90	17.46	10.58	1.00	13.48	3.57	3.18
30000	18.54	45.73	16.56	17.09	10.99	1.00	14.00	3.90	3.21
30500	18.62	45.60	15.78	17.65	10.71	1.01	14.06	4.12	3.23
31000	18.74	45.61	15.52	18.16	10.57	1.01	14.58	4.45	3.21
31500	18.85	46.08	15.78	19.62	11.08	1.01	14.09	4.53	3.24
32000	18.99	45.27	17.04	22.36	10.07	1.01	15.10	5.01	3.28
32500	19.09	45.53	18.42	24.80	10.32	1.01	14.92	4.84	3.24
33000	19.13	45.59	20.87	21.05	10.37	1.00	15.39	5.36	3.19
33500	19.08	45.18	21.79	16.40	9.83	0.98	15.63	5.74	3.26
34000	19.13	43.45	18.10	13.70	7.80	0.97	15.83	5.99	3.25
34500	19.06	44.85	14.58	10.82	8.70	0.94	16.60	6.63	3.24
35000	18.85	46.12	13.30	9.39	9.82	0.92	16.70	6.39	3.21
35500	18.62	45.17	11.36	7.98	8.37	0.89	16.06	6.27	3.23
36000	18.34	45.88	11.22	7.43	9.07	0.88	15.68	6.08	3.25
36500	18.26	46.87	11.63	6.76	9.92	0.84	16.37	6.14	3.36
37000	18.28	47.48	11.84	6.49	10.45	0.83	15.48	5.75	3.45
37500	18.23	48.03	12.41	6.14	10.99	0.80	15.24	5.93	3.13
38000	17.85	48.82	13.21	6.21	12.79	0.80	15.71	6.53	3.63
38500	17.33	47.35	12.43	6.44	11.53	0.82	15.34	6.01	3.34
39000	17.48	46.65	11.47	6.47	10.27	0.83	15.59	6.65	3.31
39500	17.58	47.59	10.70	6.41	11.08	0.84	15.08	6.92	3.40
40000	17.36	48.20	10.45	6.46	12.17	0.85	15.29	7.14	3.45
40500	16.83	51.08	9.54	6.92	18.16	0.89	17.21	8.26	3.45
41000	16.09	52.97	8.40	7.41	24.30	0.94	16.58	8.28	3.60
41500	15.21	57.02	7.49	7.96	42.34	0.99	16.98	8.59	3.78
42000	14.33	60.54	7.01	8.12	69.05	1.02	17.72	8.70	3.82
42500	13.43	63.85	6.92	8.19	112.08	1.02	18.56	8.58	3.81
43000	12.49	64.41	7.31	8.31	136.68	1.01	18.33	8.23	3.86
43500	11.46	63.82	8.05	7.52	143.97	0.95	18.31	7.91	3.97

Note: Test data of Die packaged in industry standard 3x3 12-lead MCL package



Typical Performance Data

Definitions:

Input Return Loss = -S11 (dB)

Gain(Power Gain) = S21 (dB)

Reverse Isolation = -S12 (dB)

Output Return Loss = -S22 (dB)

TEST CONDITIONS: Vd = 3.8V, Id = 24mA @ Temperature = +25°C

FREQ	Gain	Isolation	Input Return Loss	Output Return Loss	Stability		IP-3 Output	1dB Comp. Output	Noise Figure
					K	Measure			
(MHz)	(dB)	(dB)	(dB)	(dB)	K	Measure	(dBm)	(dBm)	(dB)
20000	14.16	56.82	4.70	13.49	42.91	1.28	9.99	-0.27	4.76
20500	14.94	55.25	5.60	12.50	35.47	1.20	9.46	-0.22	4.45
21000	15.59	53.46	6.60	12.18	28.79	1.14	9.82	-0.11	4.17
21500	16.10	53.26	7.79	12.19	28.35	1.09	9.83	0.19	3.99
22000	16.44	52.66	9.16	11.98	26.72	1.05	11.03	0.58	3.78
22500	16.66	54.13	10.20	12.22	31.84	1.03	10.99	0.59	3.72
23000	16.84	52.94	11.11	12.31	27.79	1.01	11.12	0.95	3.61
23500	17.00	52.26	12.09	12.84	25.81	1.00	10.86	0.85	3.54
24000	17.18	51.66	13.21	13.08	24.03	0.99	10.72	1.04	3.51
24500	17.37	50.36	14.38	13.06	20.49	0.98	11.38	1.16	3.44
25000	17.55	49.59	15.94	13.53	18.65	0.98	11.11	1.18	3.40
25500	17.69	49.11	18.01	13.96	17.61	0.97	10.80	1.56	3.37
26000	17.78	48.57	18.60	14.82	16.53	0.98	11.58	1.69	3.30
26500	17.85	47.67	18.10	15.49	14.85	0.99	12.11	1.95	3.26
27000	17.92	46.90	17.49	16.16	13.51	0.99	12.14	2.00	3.25
27500	18.04	46.55	17.38	16.59	12.81	0.99	11.15	2.16	3.18
28000	18.19	46.27	17.67	17.65	12.26	1.00	12.56	2.35	3.25
28500	18.27	45.65	18.65	17.88	11.36	1.00	12.23	2.58	3.17
29000	18.30	45.49	18.53	17.55	11.10	0.99	12.56	2.87	3.21
29500	18.30	45.32	17.91	17.45	10.86	1.00	12.89	3.18	3.25
30000	18.31	45.40	16.57	17.06	10.86	1.00	13.14	3.41	3.23
30500	18.40	45.43	15.77	17.59	10.77	1.01	13.44	3.74	3.22
31000	18.53	45.59	15.51	18.08	10.81	1.01	13.85	4.08	3.24
31500	18.65	45.47	15.72	19.53	10.58	1.01	13.84	4.07	3.26
32000	18.79	45.00	16.98	22.12	9.98	1.01	14.57	4.56	3.31
32500	18.91	45.29	18.31	24.38	10.26	1.01	14.44	4.50	3.24
33000	18.95	45.01	20.71	20.75	9.89	1.00	15.26	5.02	3.28
33500	18.91	44.79	21.69	16.24	9.57	0.98	14.92	5.31	3.26
34000	18.96	43.19	18.11	13.56	7.71	0.96	15.82	5.56	3.25
34500	18.90	45.09	14.60	10.68	9.08	0.94	16.05	6.31	3.31
35000	18.70	45.54	13.33	9.26	9.32	0.91	15.64	6.08	3.20
35500	18.48	44.60	11.38	7.87	7.94	0.89	15.47	5.87	3.27
36000	18.20	45.60	11.23	7.32	8.88	0.87	15.31	5.67	3.21
36500	18.12	46.89	11.63	6.65	10.03	0.84	15.54	5.84	2.97
37000	18.13	46.61	11.85	6.39	9.55	0.82	14.88	5.44	3.10
37500	18.09	47.55	12.43	6.04	10.50	0.80	15.17	5.64	3.18
38000	17.71	48.43	13.22	6.11	12.34	0.79	14.85	6.12	3.30
38500	17.19	47.59	12.45	6.33	11.97	0.81	14.98	5.70	3.37
39000	17.33	46.27	11.52	6.37	9.95	0.83	15.46	6.33	3.44
39500	17.43	47.34	10.76	6.32	10.90	0.84	14.76	6.73	3.36
40000	17.20	49.30	10.53	6.36	14.00	0.84	14.92	6.97	3.39
40500	16.67	49.68	9.62	6.84	15.67	0.89	16.48	8.00	3.46
41000	15.93	52.65	8.46	7.34	23.83	0.94	16.25	8.06	3.68
41500	15.05	56.32	7.56	7.91	39.83	0.99	16.56	8.36	3.75
42000	14.17	59.39	7.07	8.08	61.70	1.01	17.81	8.42	3.85
42500	13.27	61.86	6.98	8.16	90.91	1.02	18.50	8.29	3.88
43000	12.33	65.10	7.37	8.28	151.17	1.01	17.47	7.95	3.86
43500	11.30	62.68	8.12	7.49	128.72	0.95	17.09	7.72	4.00

Note: Test data of Die packaged in industry standard 3x3 12-lead MCL package

Typical Performance Data

Definitions:

Input Return Loss = -S11 (dB)

Gain(Power Gain) = S21 (dB)

Reverse Isolation = -S12 (dB)

Output Return Loss = -S22 (dB)

TEST CONDITIONS: Vd = 4.2V, Id = 27mA @ Temperature = +25°C

FREQ	Gain	Isolation	Input Return Loss	Output Return Loss	Stability		IP-3 Output	1dB Comp. Output	Noise Figure
					K	Measure			
(MHz)	(dB)	(dB)	(dB)	(dB)	K	Measure	(dBm)	(dBm)	(dB)
20000	14.64	56.75	4.83	13.40	40.87	1.27	10.92	0.47	4.70
20500	15.41	55.65	5.74	12.41	35.60	1.19	10.46	0.52	4.38
21000	16.06	53.85	6.77	12.09	28.82	1.13	10.79	0.72	4.14
21500	16.56	52.95	8.00	12.11	26.13	1.08	10.82	0.93	3.90
22000	16.89	53.39	9.41	11.90	27.77	1.04	12.01	1.32	3.75
22500	17.12	53.55	10.48	12.13	28.40	1.02	11.97	1.43	3.66
23000	17.30	53.37	11.42	12.22	27.81	1.01	12.07	1.78	3.55
23500	17.47	52.72	12.43	12.75	25.91	1.00	11.83	1.69	3.50
24000	17.66	52.10	13.57	12.99	23.98	0.99	11.76	1.79	3.45
24500	17.85	51.08	14.78	12.97	21.12	0.98	12.40	1.92	3.42
25000	18.03	49.96	16.40	13.42	18.44	0.97	12.08	2.03	3.38
25500	18.17	49.47	18.53	13.85	17.39	0.97	11.84	2.42	3.33
26000	18.26	48.61	19.02	14.69	15.71	0.98	12.57	2.55	3.27
26500	18.33	48.22	18.37	15.37	14.95	0.98	12.91	2.73	3.24
27000	18.40	47.78	17.69	16.02	14.14	0.99	13.40	2.77	3.20
27500	18.52	47.19	17.54	16.48	13.06	0.99	12.06	3.03	3.21
28000	18.66	46.44	17.80	17.53	11.85	1.00	13.55	3.20	3.18
28500	18.74	45.87	18.70	17.80	11.05	0.99	13.20	3.32	3.15
29000	18.75	45.96	18.54	17.55	11.13	0.99	13.77	3.61	3.21
29500	18.74	45.85	17.88	17.48	10.97	1.00	13.66	3.92	3.22
30000	18.74	45.57	16.55	17.13	10.55	1.00	14.20	4.24	3.21
30500	18.81	45.53	15.78	17.72	10.39	1.01	14.46	4.45	3.20
31000	18.93	45.91	15.56	18.22	10.72	1.01	14.88	4.88	3.21
31500	19.04	45.51	15.81	19.77	10.17	1.01	14.87	4.85	3.24
32000	19.16	45.79	17.15	22.66	10.49	1.01	15.52	5.33	3.27
32500	19.25	45.88	18.53	25.33	10.56	1.01	15.54	5.24	3.25
33000	19.28	45.60	20.99	21.40	10.21	1.00	15.45	5.75	3.27
33500	19.23	45.13	21.90	16.60	9.62	0.98	16.18	6.13	3.26
34000	19.27	43.18	18.04	13.85	7.45	0.97	16.88	6.37	3.34
34500	19.19	45.05	14.55	10.94	8.78	0.94	17.48	7.00	3.25
35000	18.98	46.43	13.29	9.52	10.05	0.92	16.36	6.76	3.18
35500	18.75	45.34	11.35	8.09	8.45	0.90	16.71	6.55	3.27
36000	18.46	45.96	11.23	7.54	9.08	0.88	16.46	6.35	3.15
36500	18.39	47.13	11.62	6.85	10.13	0.85	16.64	6.41	2.99
37000	18.41	47.56	11.83	6.60	10.46	0.83	16.41	6.12	3.20
37500	18.36	48.26	12.41	6.24	11.20	0.81	16.13	6.20	3.59
38000	17.97	49.32	13.20	6.32	13.45	0.80	16.25	6.90	3.24
38500	17.46	46.92	12.39	6.54	10.89	0.82	16.24	6.39	3.32
39000	17.61	46.84	11.43	6.56	10.42	0.84	16.12	7.02	3.35
39500	17.72	47.43	10.64	6.50	10.77	0.85	15.55	7.17	3.38
40000	17.50	48.84	10.37	6.54	12.95	0.85	15.99	7.37	3.47
40500	16.97	51.12	9.47	6.99	17.98	0.89	17.72	8.44	3.49
41000	16.23	54.18	8.33	7.47	27.54	0.94	17.28	8.53	3.61
41500	15.35	59.95	7.43	8.01	58.42	1.00	18.17	8.84	3.74
42000	14.47	61.47	6.95	8.16	75.50	1.02	19.07	8.95	3.81
42500	13.57	63.60	6.86	8.22	106.83	1.03	19.33	8.84	3.82
43000	12.63	68.16	7.25	8.32	206.64	1.01	19.02	8.42	3.87
43500	11.60	63.02	8.00	7.54	129.01	0.95	19.71	8.15	3.97

Note: Test data of Die packaged in industry standard 3x3 12-lead MCL package

Typical Performance Curves

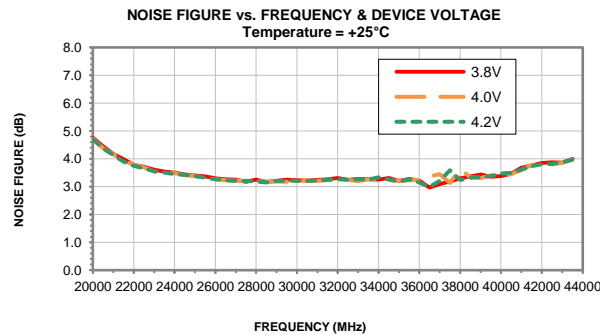
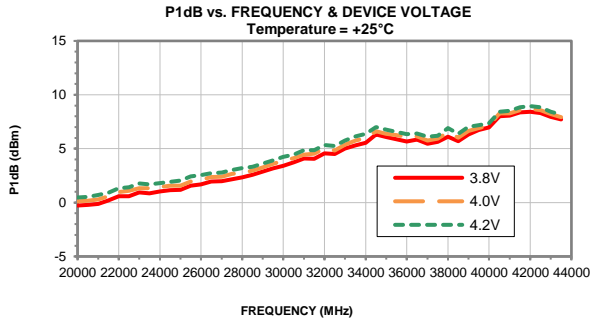
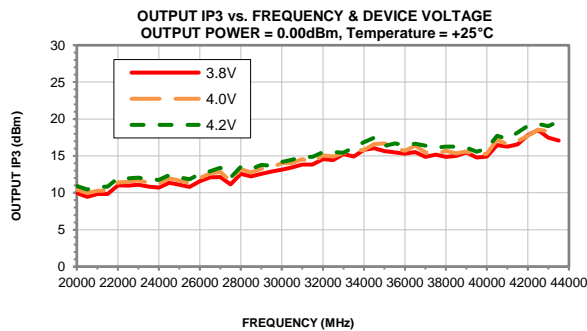
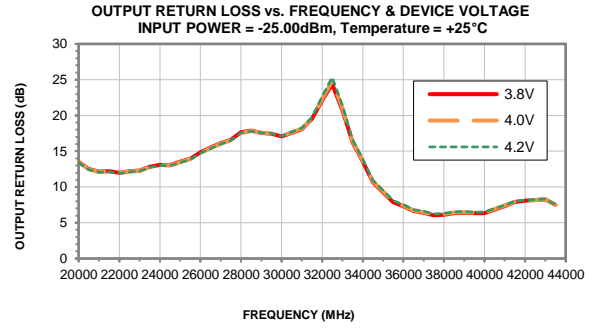
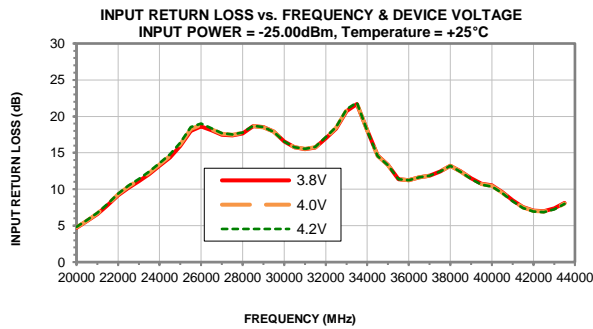
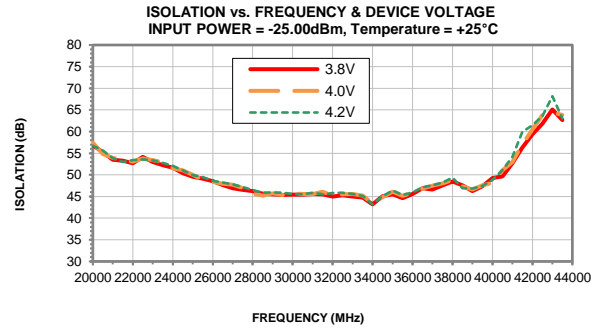
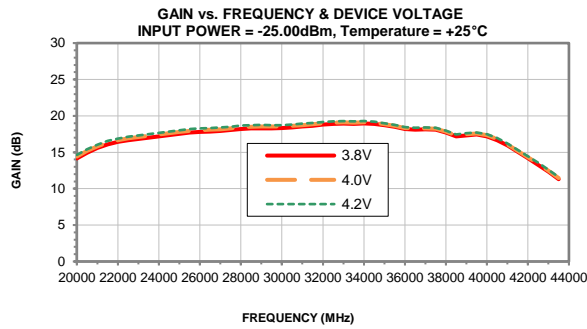

Note: Test data of Die packaged in industry standard 3x3 12-lead MCL package

All Mini-Circuits products are manufactured under exacting quality assurance and control standards, and are capable of meeting published specifications after being subjected to any or all of the following physical and environmental test.

Specification	Test/Inspection Condition	Reference/Spec
Operating Temperature	-40° to 85° C or -40° to 105° C or -55° to 105° C or -45° to 105° C Ambient Environment	Refer to Individual Model Data Sheet
Storage Environment (Die)	-65° to 150°C	Individual Model Data Sheet
Storage Environment(Packaging)	-40° to 70°C and 40 to 60% humidity (In Factory Shipped Package)	