



## MMIC SURFACE MOUNT

# Low Noise Amplifier

## TSS-23ULN+

50Ω 10 to 2000 MHz Shutdown Feature

### THE BIG DEAL

- Low Noise Figure, Typ. 0.4 dB
- High Gain, Typ. 20 dB
- High OIP3, Typ. +37.3 dBm
- Fast Shutdown Feature, 7.5 ns
- Single Supply Voltage, +5 V at 70.6 mA
- 2x2 mm 8-Lead QFN-style Package

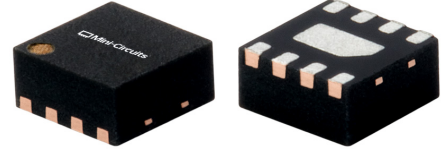

Generic photo used for illustration purposes only

### APPLICATIONS

- Cellular Infrastructure
- Satellite Communications
- Radar, EW, and ECM Defense Systems

### FUNCTIONAL DIAGRAM (TOP VIEW)

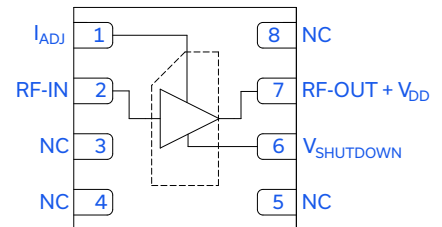

### PRODUCT OVERVIEW

The TSS-23ULN+ is a pHEMT-based wideband, ultra-low noise MMIC amplifier with high P1dB, high IP3, and voltage-controlled shutdown capability. Operating from 10 to 2000 MHz, this amplifier features typical 0.4 dB noise figure, 20 dB gain, +20.3 dBm P1dB, and +37.3 dBm OIP3. This combination of characteristics makes it ideal for sensitive receiver applications. TSS-23ULN+ operates on a single +5 V supply and comes in a small, low profile, 2x2 mm QFN-style package for ease of integration into dense circuit board layouts.

### KEY FEATURES

Features	Advantages
Ultra-Low Noise Figure, Typ. 0.4 dB	Operating from a single supply, this ultra-low noise MMIC enables low system noise figure performance, without the need for complicated discrete-based solutions.
High Gain, Typ. 20 dB	The MMIC amplifier's high gain enables fewer system components in receiver signal chains.
Shutdown Feature	A voltage-controlled shutdown feature allows the part to be quickly disabled to conserve power when not in use.
High Dynamic Range <ul style="list-style-type: none"> <li>• Gain, Typ. 20 dB</li> <li>• OIP3, Typ. +37.3 dBm</li> <li>• P1dB, Typ. +20.3 dBm</li> </ul>	The MMIC amplifier's unique combination of low noise figure, high gain, high P1dB, and high OIP3 enables optimum performance in sensitive high dynamic range receivers.
2x2 mm 8-Lead QFN-Style Package	Small footprint saves space in dense layouts while providing low inductance, repeatable transitions, and excellent thermal contact to the PCB. Industry standard packaging allows for ease of assembly in high volume manufacturing processes.





MMIC SURFACE MOUNT

## Low Noise Amplifier

TSS-23ULN+

Mini-Circuits

50Ω 10 to 2000 MHz Shutdown Feature

ELECTRICAL SPECIFICATIONS<sup>1</sup> AT +25°C AND Z<sub>0</sub> = 50Ω UNLESS NOTED OTHERWISE

Parameter	Condition (MHz)	Amplifier - ON V <sub>DD</sub> = +5 V (V <sub>SHUTDOWN</sub> = 0 V)			Amplifier - ON V <sub>DD</sub> = +3 V (V <sub>SHUTDOWN</sub> = 0 V)	Amplifier - OFF V <sub>DD</sub> = +5 V (V <sub>SHUTDOWN</sub> = +5 V)	Units
		Min.	Typ.	Max.	Typ.	Typ.	
Frequency Range		10		2000	10-2000	10-2000	MHz
Gain	10	28.2	29.4		27.7	-21.3	dB
	500	23.6	24.7		23.5	-30.3	
	1000	18.9	20.0		18.9	-33.3	
	1500	15.7	16.9		15.9	-30.4	
	2000	13.3	14.5		13.6	-24.7	
Input Return Loss	10		9		7		dB
	500		13		10		
	1000		15		12		
	1500		16		13		
	2000		17		14		
Output Return Loss	10		20		19		dB
	500		14		16		
	1000		13		16		
	1500		12		15		
	2000		12		15		
Isolation	10-2000		26.5		25.4	30.2	dB
Output Power at 1 dB Compression (P1dB)	10		+21.9		+16.8		dBm
	500		+20.4		+15.9		
	1000		+20.3		+15.8		
	1500		+19.2		+16.5		
	2000		+19.4		+16.2		
Output Third-Order Intercept Point (P <sub>OUT</sub> = +4 dBm/Tone)	10		+34.3		+28.8		dBm
	500		+36.8		+28.0		
	1000		+37.3		+28.5		
	1500		+38.3		+28.7		
	2000		+36.1		+28.7		
Noise Figure <sup>2</sup>	10		1.4		1.5		dB
	500		0.3		0.3		
	1000		0.4		0.3		
	1500		0.4		0.5		
	2000		0.5		0.4		
ON Time (50% V <sub>CTRL</sub> to 90% RF)			9.5				ns
RISE Time (10% RF to 90% RF)			5.4				ns
FALL Time (90% RF to 10% RF)			6.2				ns
OFF Time (50% V <sub>CTRL</sub> to 10% RF)			7.5				ns
Device Operating Voltage (V <sub>DD</sub> )		+2.7	+5	+5.25	+3	+5	V
Device Operating Current (I <sub>DD</sub> ) <sup>3</sup>			70.6		36.5	3	mA
Device Shutdown Voltage (V <sub>SHUTDOWN</sub> )			0		0	+5	V
Device Shutdown Current (I <sub>SHUTDOWN</sub> )			0.27		0.27	0.69	mA
Device Current Variation vs. Temperature <sup>4</sup>			0.007		0.007		mA/°C
Device Current Variation vs. Voltage <sup>5</sup>			0.0168		0.0168		mA/mV

1. Tested in Mini-Circuits Characterization Test/Evaluation Board TB-TSS-23ULNC+. See Figure 2. Board loss de-embedded to the device.

2. Typical value verified and set by averaging performance across multiple measurement setups.

3. Current at P<sub>IN</sub> = -25 dBm. Increases to 90 mA at P1dB.

4. (Current at +105°C - Current at -45°C) / (+150°C)

5. (Current at +5.25 V - Current at +4.75 V) / (+0.5 V)





### TYPICAL PERFORMANCE GRAPHS

Note: All data taken at nominal condition  $V_{DD} = +5\text{ V}$  and  $V_{SHUTDOWN} = 0\text{ V}$  unless noted otherwise.

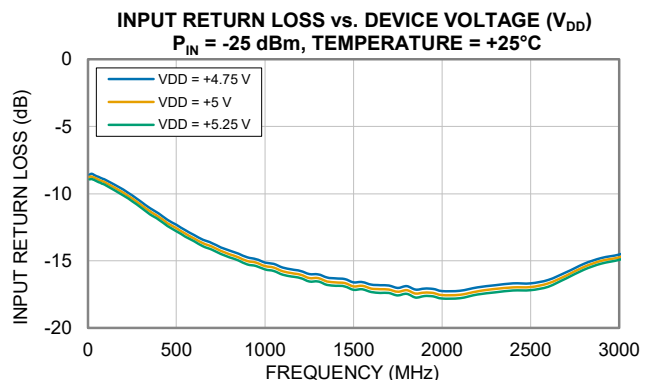
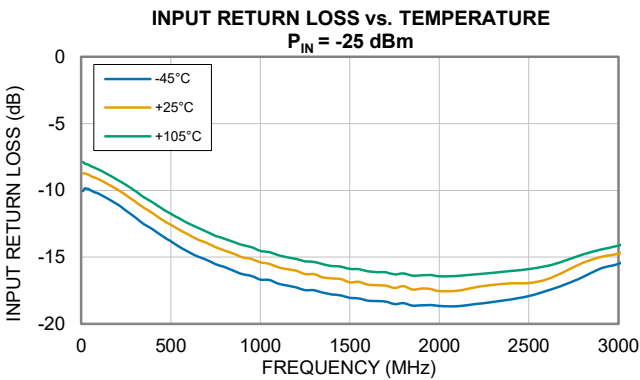
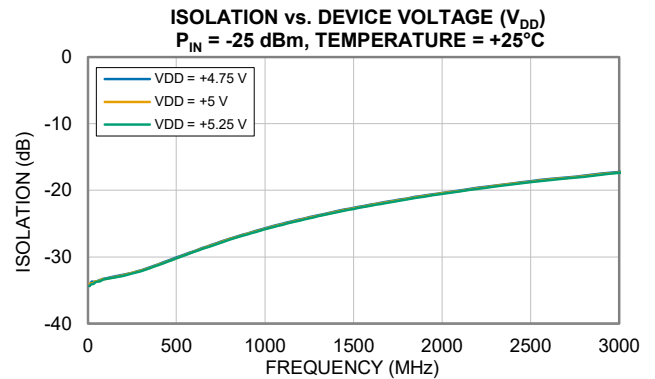
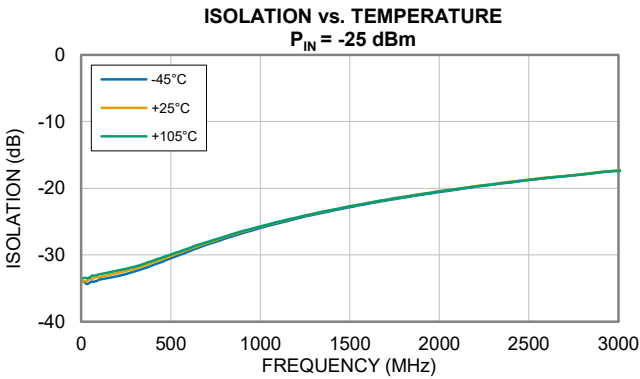
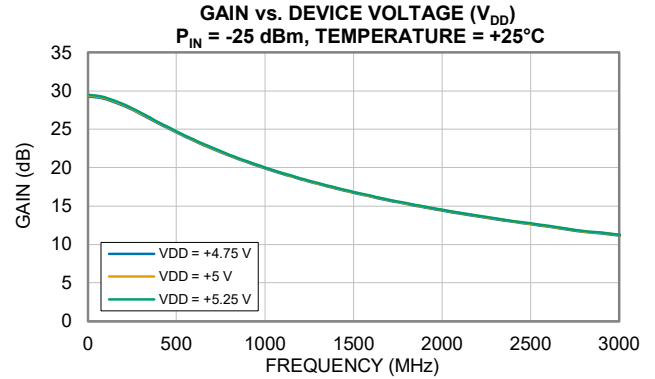
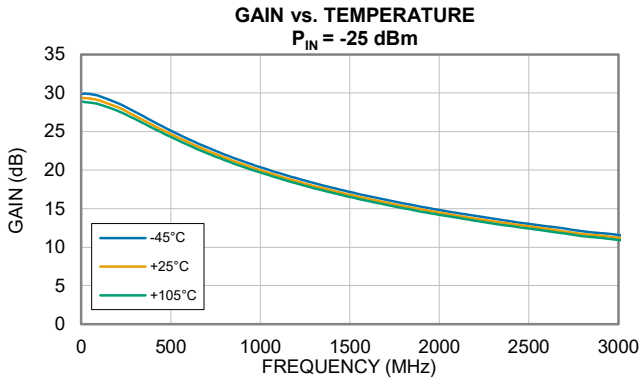



### TYPICAL PERFORMANCE GRAPHS

Note: All data taken at nominal condition  $V_{DD} = +5\text{ V}$  and  $V_{SHUTDOWN} = 0\text{ V}$  unless noted otherwise.

**OUTPUT RETURN LOSS vs. TEMPERATURE**  
 $P_{IN} = -25\text{ dBm}$

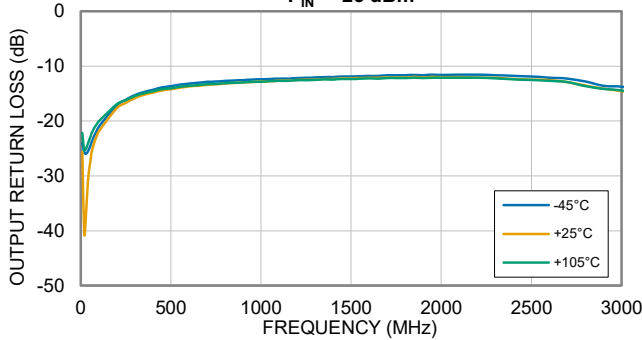

**OUTPUT RETURN LOSS vs. DEVICE VOLTAGE ( $V_{DD}$ )**  
 $P_{IN} = -25\text{ dBm}$ , TEMPERATURE = +25°C

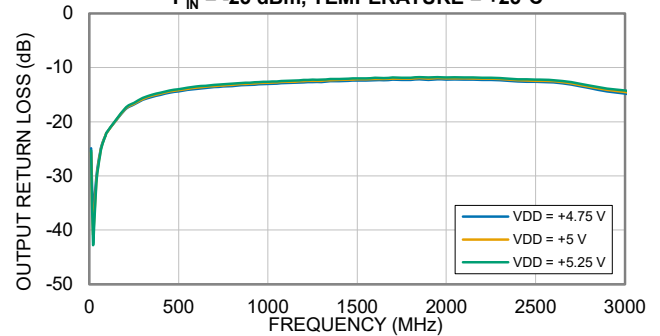

**P1dB vs. TEMPERATURE**

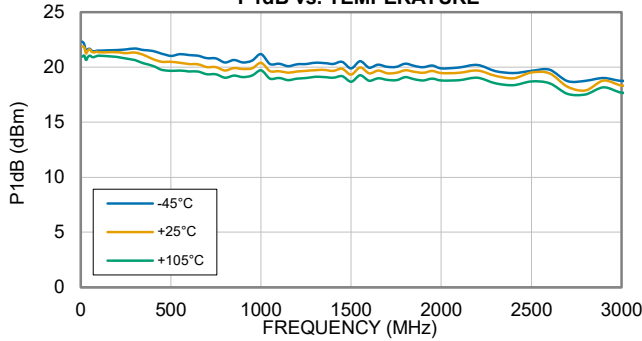

**P1dB vs. DEVICE VOLTAGE ( $V_{DD}$ )**  
TEMPERATURE = +25°C

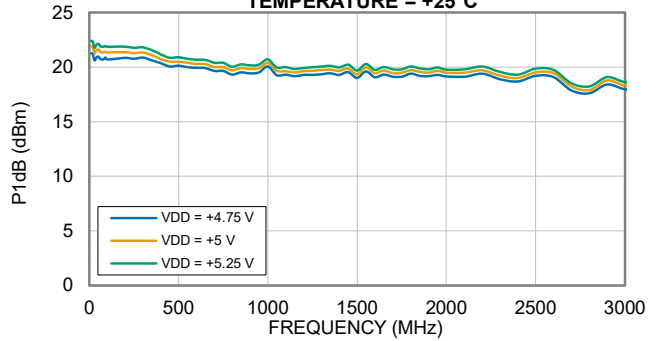

**OUTPUT IP3 vs. TEMPERATURE**  
 $P_{OUT} = +4\text{ dBm/TONE}$

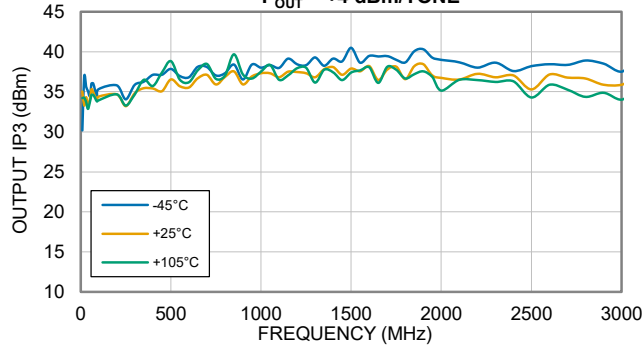

**OUTPUT IP3 vs. DEVICE VOLTAGE ( $V_{DD}$ )**  
 $P_{OUT} = +4\text{ dBm/TONE}$ , TEMPERATURE = +25°C

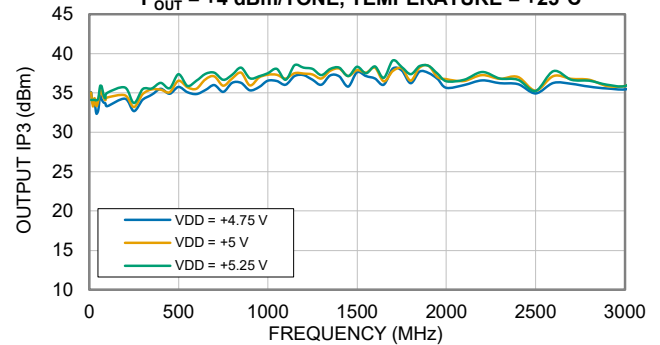



### TYPICAL PERFORMANCE GRAPHS

Note: All data taken at nominal condition  $V_{DD} = +5\text{ V}$  and  $V_{SHUTDOWN} = 0\text{ V}$  unless noted otherwise.

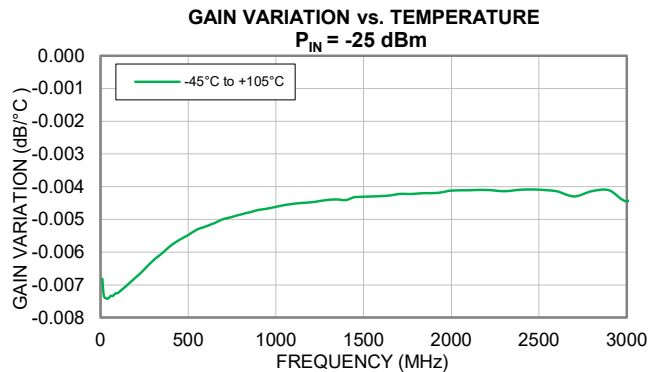
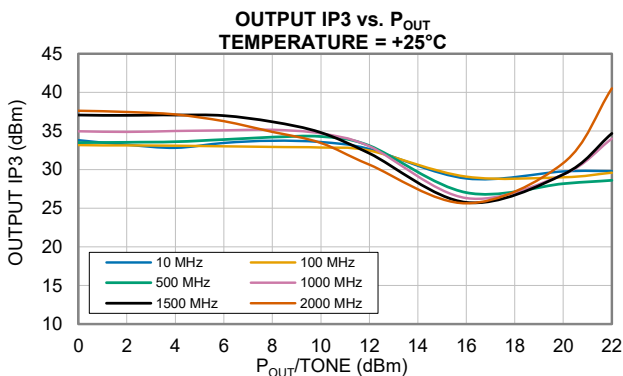
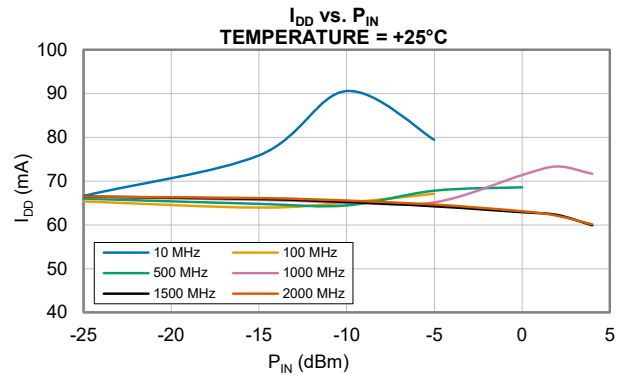
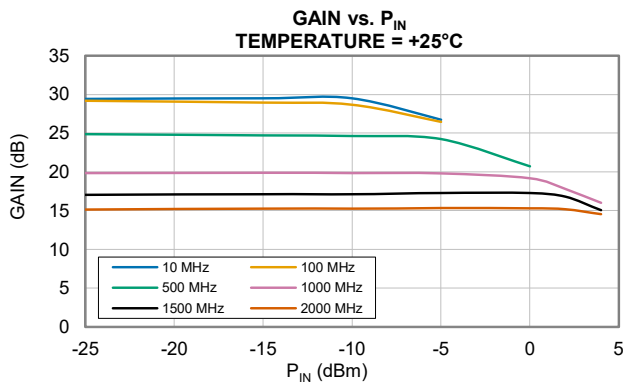
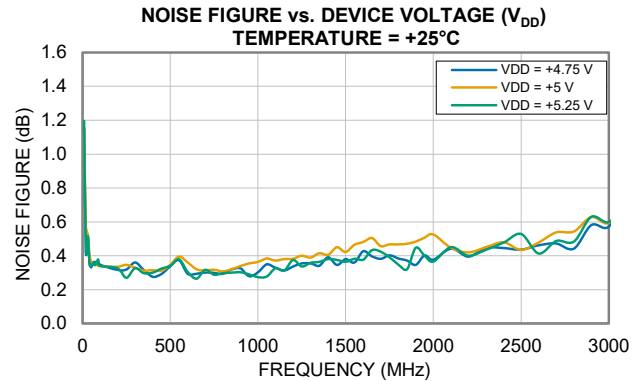
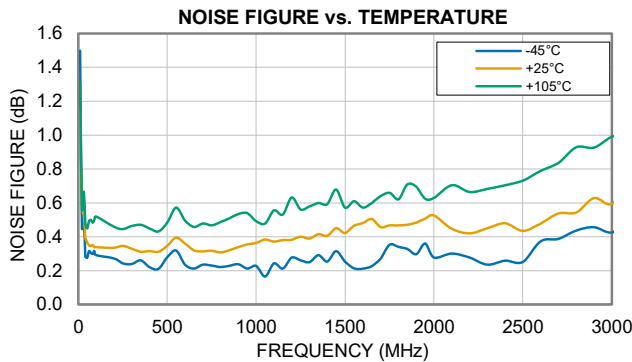



### TYPICAL LOW VOLTAGE PERFORMANCE GRAPHS

Note: All data taken at nominal condition  $V_{SHUTDOWN} = 0$  V unless noted otherwise.

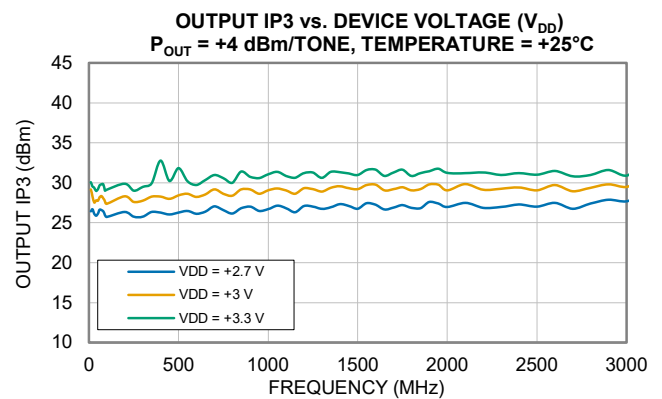
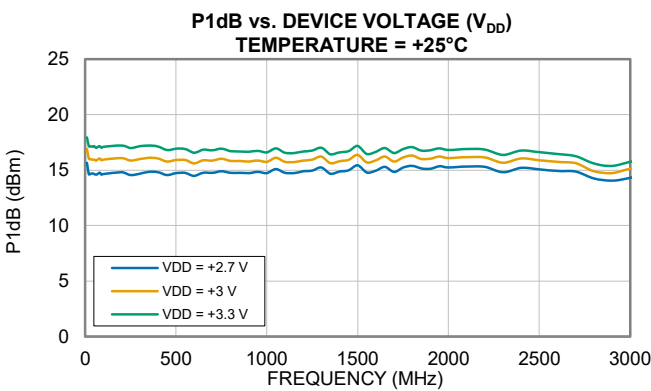
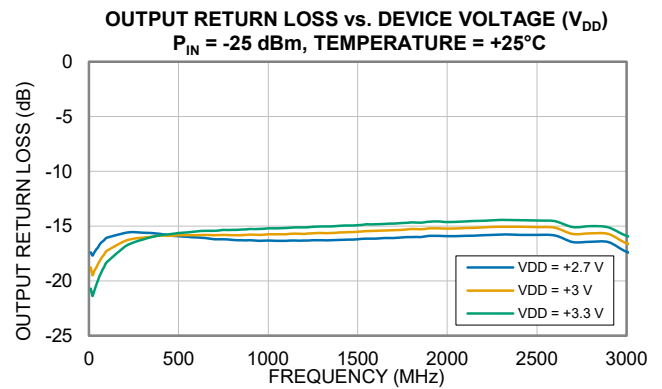
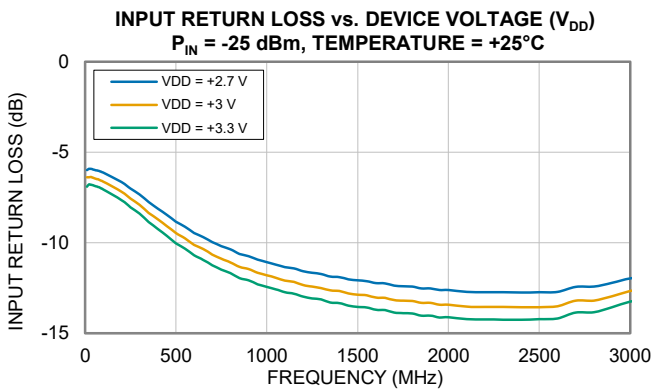
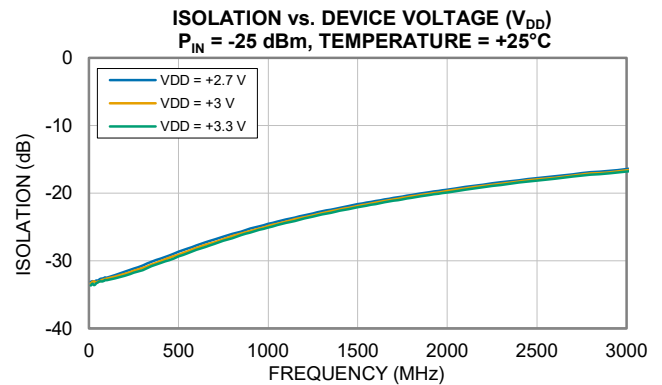
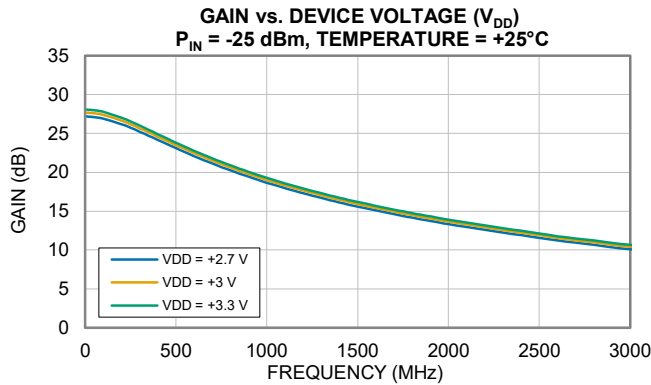



MMIC SURFACE MOUNT

# Low Noise Amplifier

TSS-23ULN+

Mini-Circuits

50Ω 10 to 2000 MHz Shutdown Feature

## TYPICAL LOW VOLTAGE PERFORMANCE GRAPHS

Note: All data taken at nominal condition  $V_{SHUTDOWN} = 0$  V unless noted otherwise.

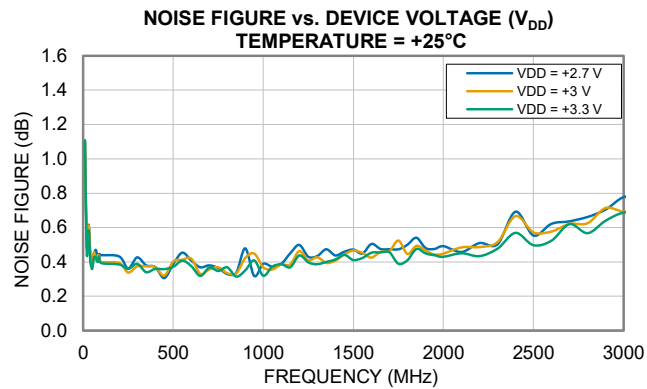

ABSOLUTE MAXIMUM RATINGS<sup>6</sup>

Parameter	Ratings
Operating Temperature	-45°C to +105°C
Storage Temperature	-65°C to +150°C
Total Power Dissipation	0.9 W
Junction Temperature <sup>7</sup>	+150°C
Input Power (CW)	
$V_{DD} = +5\text{ V}$ & $V_{SHUTDOWN} = 0\text{ V}$	+21 dBm
$V_{DD} = +3\text{ V}$ & $V_{SHUTDOWN} = 0\text{ V}$	+21 dBm
DC Voltage on RF-OUT & $V_{DD}$	
$V_{SHUTDOWN} = 0\text{ V}$	+10 V
$V_{SHUTDOWN} = +5\text{ V}$	+10 V
DC Voltage on RF-IN	
$V_{SHUTDOWN} = 0\text{ V}$	+1 V
$V_{SHUTDOWN} = +5\text{ V}$	+1 V
DC Voltage on $V_{SHUTDOWN}$	
$V_{DD} = +5\text{ V}$	+10 V
$V_{DD} = +3\text{ V}$	+10 V
DC Current on RF-OUT & $V_{DD}$	
$V_{SHUTDOWN} = 0\text{ V}$	100 mA
$V_{SHUTDOWN} = +5\text{ V}$	10 mA
DC Current $V_{SHUTDOWN}$	
$V_{DD} = +5\text{ V}$	10 mA
$V_{DD} = +3\text{ V}$	10 mA

6. Permanent damage may occur if any of these limits are exceeded. Maximum ratings are not intended for continuous normal operation.

7. Peak temperature on top of Die.

## POWER ON / POWER OFF LOGIC

Amplifier State	$V_{DD}$			$V_{SHUTDOWN}$		
	Min	Typ.	Max	Min	Typ.	Max
Amplifier - ON ( $V_{DD} = +5\text{ V}$ )	+2.7 V	+5 V	+5.25 V	0 V	0 V	+1.3 V
Amplifier - OFF ( $V_{DD} = +5\text{ V}$ )				+1.4 V	+5 V	+5.25 V
Amplifier - ON ( $V_{DD} = +3\text{ V}$ )	+2.7 V	+3 V	+5.25 V	0 V	0 V	+1.3 V
Amplifier - OFF ( $V_{DD} = +3\text{ V}$ )				+1.4 V	+3 V	+5.25 V

## THERMAL RESISTANCE

Parameter	Ratings
Thermal Resistance ( $\theta_{JC}$ ) <sup>8</sup>	48.7°C/W

8.  $\theta_{JC}$  = (Hot Spot Temperature on Die - Temperature at Ground Lead)/Dissipated Power

## ESD RATING

	Class	Voltage Range	Reference Standard
HBM	1A	250 V to < 500 V	ANSI/ESDA/JEDEC JS-001-2023
CDM	C3	> 1000 V	ANSI/ESDA/JEDEC JS-002-2022



ESD HANDLING PRECAUTION: This device is designed to be Class 1A for HBM. Static charges may easily produce potentials higher than this with improper handling and can discharge into DUT and damage it. As a preventive measure Industry standard ESD handling precautions should be used at all times to protect the device from ESD damage.

## MSL RATING

Moisture Sensitivity: MSL1 in accordance with IPC/JEDEC J-STD-020E /JEDEC J-STD-033C



### FUNCTIONAL DIAGRAM

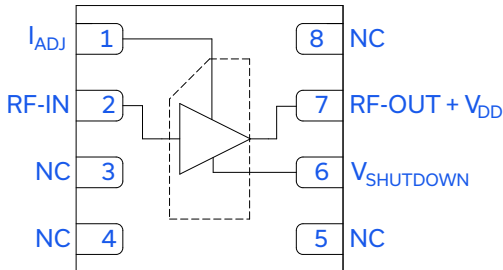

Figure 1. TSS-23ULN+ Functional Diagram

### PAD DESCRIPTION

Function	Pad Number	Description (Refer to Figure 2)
RF-OUT + $V_{DD}$	7	RF-OUT + $V_{DD}$ Pad connects to RF-Output port and voltage input port, $V_{DD}$ .
$V_{SHUTDOWN}$	6	DC Input Pad connects to voltage input port, $V_{SHUTDOWN}$ .
RF-IN	2	RF-IN Pad connects to RF-Input port.
$I_{ADJ}$	1	Current adjust pad. Must be left floating for nominal operation.
NC	3-5 & 8	Not used internally. May be connected to ground or left floating. Grounded on evaluation board.
GND	Paddle	Connects to ground.

### EVALUATION BOARD

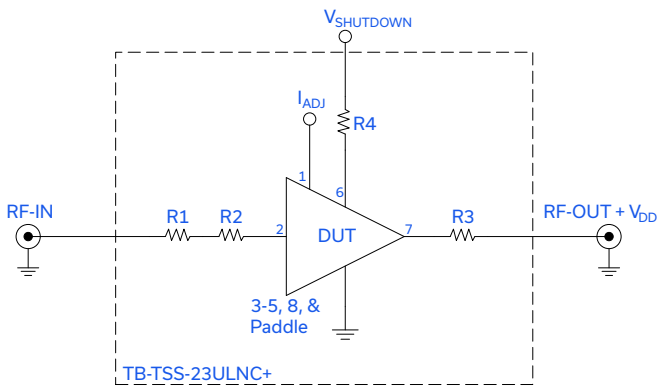

Figure 2. TSS-23ULN+ Evaluation and Application Circuit

### Electrical Parameters and Conditions

Gain, Return Loss, Output Power at 1 dB Compression (P1dB), Output IP3 (OIP3), and Noise Figure measured using N5242A PNA-X microwave network analyzer.

#### Conditions:

1. Gain and Return Loss:  $P_{IN} = -25$  dBm
2. Output IP3 (OIP3): Two tones, spaced 1 MHz apart, +4 dBm/tone at output.

### Power ON/Power OFF Sequence:

Caution: Permanent damage to the device will occur if the Power ON and Power OFF sequences are not followed.

#### POWER ON:

1. Set  $V_{SHUTDOWN} = 0$  V for ON mode or  $V_{SHUTDOWN} = +5$  V for OFF mode.
2. Set  $V_{DD} = +5$  V.
3. Turn on  $V_{SHUTDOWN}$ .
4. Turn on  $V_{DD}$ .

#### POWER OFF:

1. Turn off RF signal.
2. Turn off  $V_{DD}$ .
3. Turn off  $V_{SHUTDOWN}$ .

Component	Size	Value	Part Number	Manufacturer
R1-R4	0402	0Ω	RK73Z1ETTP	KOA Speer



### CASE STYLE DRAWING

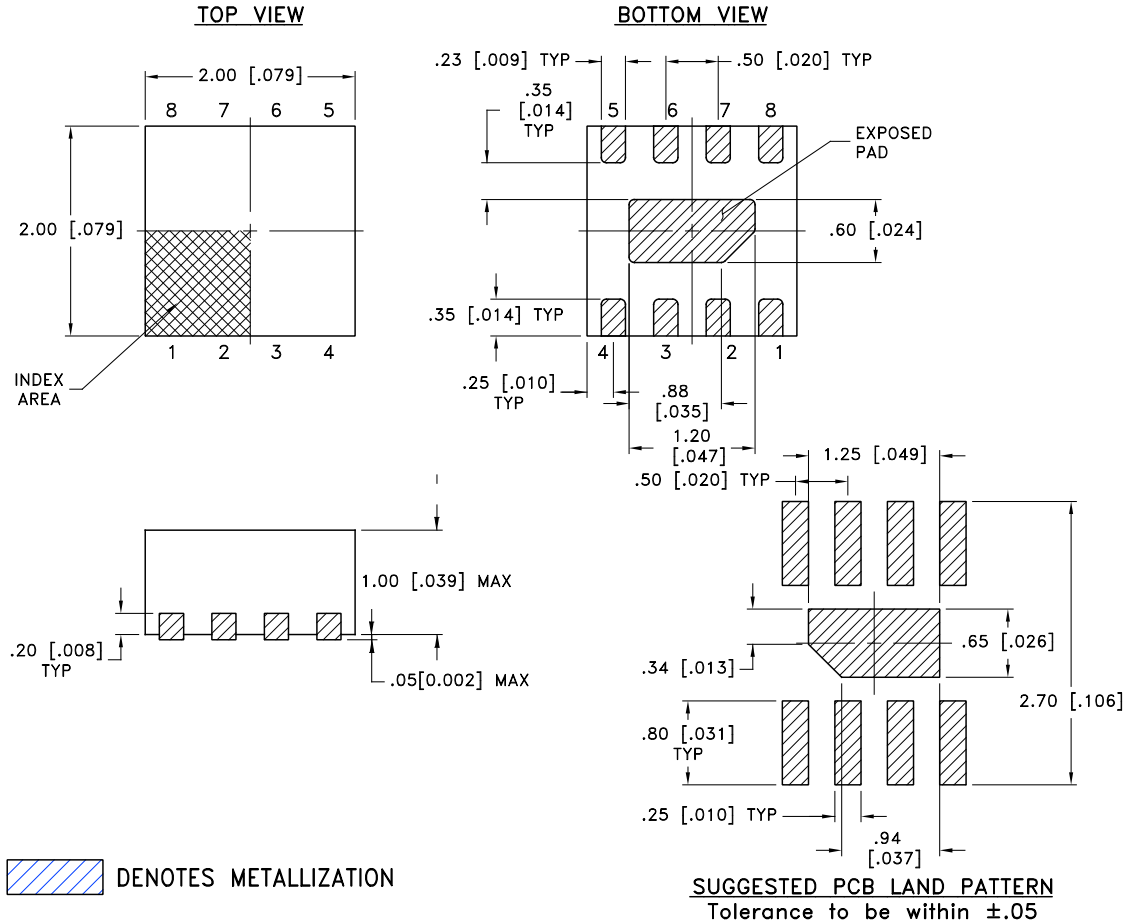

Weight: 0.006 grams  
Dimensions are in mm [Inches]. Tolerances: 2Pl. ± 0.05 mm

### PRODUCT MARKING

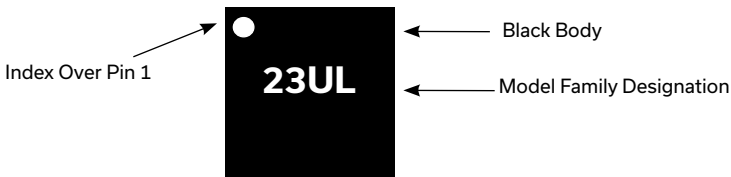

Marking may contain other features or characters for internal lot control.



MMIC SURFACE MOUNT

# Low Noise Amplifier

TSS-23ULN+

Mini-Circuits

50Ω 10 to 2000 MHz Shutdown Feature

ADDITIONAL DETAILED INFORMATION IS AVAILABLE ON OUR DASHBOARD

[CLICK HERE](#)

Performance Data & Graphs	Data Graphs S-Parameter (S2P Files) Data Set (.zip file)
Case Style	MC1631-1. Plastic package, exposed paddle, Lead Finish: Matte-Tin
RoHS Status	Compliant
Tape & Reel Standard Quantities Available on Reel	F66 7" Reels with 20, 50, 100, 200, 500, 1000, 2000, or 3000 devices
Suggested Layout for PCB Design	PL-815
Evaluation Board	TB-TSS-23ULNC+ Gerber File
Environmental Ratings	ENV08T1

NOTES

- A. Performance and quality attributes and conditions not expressly stated in this specification document are intended to be excluded and do not form a part of this specification document.
- B. Electrical specifications and performance data contained in this specification document are based on Mini-Circuits' applicable established test performance criteria and measurement instructions.
- C. The parts covered by this specification document are subject to Mini-Circuits standard limited warranty and terms and conditions (collectively, "Standard Terms"); Purchasers of this part are entitled to the rights and benefits contained therein. For a full statement of the standard terms and the exclusive rights and remedies thereunder, please visit Mini-Circuits' website at [www.minicircuits.com/terms/viewterm.html](http://www.minicircuits.com/terms/viewterm.html)



Typical Performance Data

NOTE: Use PDF Bookmarks to view DATA at required conditions

Definitions:

Input Return Loss = S11 (dB)

Gain = S21 (dB)

Isolation = S12 (dB)

Output Return Loss = S22 (dB)

TEST CONDITIONS: V<sub>DD</sub> = +2.7 V, V<sub>SHUTDOWN</sub> = 0 V, I<sub>DD</sub> = 32 mA, I<sub>SHUTDOWN</sub> = 0.0041 µA @ Temperature = +25°C

FREQ	Gain	Isolation	Input Return Loss	Output Return Loss	Stability		1dB Comp. Output	Noise Figure	IP-3 Output Pout = +4
					K	Measure			
(MHz)	(dB)	(dB)	(dB)	(dB)			(dBm)	(dB)	(dBm)
10	27.2	-33.1	-6.0	-17.4	1.0	0.9	15.7	1.1	26.4
20	27.2	-33.0	-5.9	-17.7	1.0	0.9	14.6	0.5	26.7
30	27.1	-33.0	-5.9	-17.4	1.0	0.9	14.7	0.6	26.1
40	27.1	-32.9	-5.9	-17.1	1.0	0.9	14.7	0.4	25.9
50	27.1	-32.9	-6.0	-16.9	1.0	0.9	14.7	0.4	26.2
60	27.1	-32.7	-6.0	-16.7	1.0	0.9	14.6	0.4	26.6
70	27.0	-32.6	-6.0	-16.5	1.0	0.9	14.7	0.5	26.6
80	27.0	-32.6	-6.0	-16.3	1.0	0.9	14.8	0.4	26.4
90	27.0	-32.5	-6.1	-16.2	1.0	0.9	14.6	0.4	26.0
100	26.9	-32.5	-6.1	-16.1	1.0	0.9	14.6	0.4	25.7
200	26.2	-31.6	-6.6	-15.6	1.0	0.8	14.8	0.4	26.4
250	25.7	-31.2	-7.0	-15.5	1.0	0.8	14.6	0.4	25.8
300	25.2	-30.7	-7.3	-15.6	1.1	0.8	14.7	0.4	25.7
350	24.7	-30.1	-7.8	-15.6	1.1	0.8	14.8	0.4	26.4
400	24.2	-29.7	-8.1	-15.7	1.1	0.8	14.8	0.4	26.3
450	23.6	-29.2	-8.5	-15.8	1.1	0.8	14.6	0.3	26.0
500	23.1	-28.7	-8.8	-15.9	1.1	0.8	14.7	0.4	26.3
550	22.6	-28.2	-9.1	-16.0	1.1	0.8	14.7	0.5	26.5
600	22.1	-27.7	-9.5	-16.0	1.1	0.8	14.5	0.4	26.1
650	21.6	-27.3	-9.7	-16.1	1.1	0.8	14.8	0.4	26.4
700	21.1	-26.8	-10.0	-16.2	1.1	0.8	14.8	0.4	27.0
750	20.7	-26.4	-10.2	-16.2	1.1	0.8	14.9	0.4	26.6
800	20.3	-26.0	-10.4	-16.3	1.1	0.8	14.8	0.3	26.2
850	19.8	-25.7	-10.6	-16.3	1.1	0.8	14.8	0.3	26.8
900	19.4	-25.2	-10.7	-16.3	1.1	0.8	14.7	0.5	27.0
950	19.0	-24.9	-10.9	-16.3	1.1	0.8	14.8	0.3	26.5
1000	18.7	-24.5	-11.1	-16.3	1.1	0.8	14.7	0.4	26.7
1050	18.3	-24.2	-11.2	-16.3	1.1	0.8	15.1	0.4	27.1
1100	18.0	-23.9	-11.3	-16.3	1.1	0.8	14.8	0.4	26.8
1150	17.6	-23.6	-11.4	-16.3	1.1	0.8	14.7	0.5	26.3
1200	17.3	-23.3	-11.6	-16.3	1.1	0.8	14.9	0.5	27.1
1250	17.0	-23.0	-11.7	-16.3	1.1	0.8	15.0	0.4	27.0
1300	16.7	-22.7	-11.7	-16.3	1.1	0.8	15.2	0.4	26.7
1350	16.4	-22.4	-11.9	-16.3	1.1	0.8	14.7	0.5	26.9
1400	16.1	-22.2	-11.9	-16.2	1.1	0.8	14.9	0.4	27.3
1450	15.8	-21.9	-12.0	-16.2	1.1	0.8	15.0	0.5	27.1
1500	15.6	-21.6	-12.1	-16.2	1.1	0.8	15.4	0.5	26.7
1550	15.3	-21.4	-12.1	-16.1	1.1	0.8	14.8	0.4	27.4
1600	15.1	-21.2	-12.2	-16.1	1.2	0.8	15.0	0.5	27.2
1650	14.9	-20.9	-12.2	-16.1	1.2	0.8	15.3	0.5	26.7
1700	14.6	-20.7	-12.4	-16.1	1.2	0.8	14.8	0.5	26.9
1750	14.4	-20.5	-12.4	-16.0	1.2	0.8	15.2	0.5	27.2
1800	14.2	-20.3	-12.4	-16.0	1.2	0.8	15.4	0.5	26.9
1850	13.9	-20.0	-12.5	-16.0	1.2	0.8	15.2	0.5	26.8
1900	13.7	-19.8	-12.5	-15.9	1.2	0.8	15.1	0.5	27.6
1950	13.5	-19.6	-12.6	-15.9	1.2	0.8	15.4	0.5	27.4
2000	13.3	-19.5	-12.6	-15.9	1.2	0.8	15.2	0.5	27.0
2100	13.0	-19.1	-12.7	-15.9	1.2	0.8	15.3	0.5	27.5
2200	12.6	-18.7	-12.7	-15.8	1.2	0.8	15.3	0.5	26.9
2300	12.2	-18.4	-12.7	-15.8	1.2	0.8	14.8	0.5	27.0
2400	11.9	-18.1	-12.7	-15.8	1.2	0.8	15.2	0.7	27.3
2500	11.6	-17.8	-12.7	-15.8	1.2	0.8	15.1	0.6	27.0
2600	11.2	-17.5	-12.7	-15.8	1.2	0.8	14.9	0.6	27.5
2700	10.9	-17.2	-12.4	-16.4	1.2	0.8	14.9	0.6	26.7
2800	10.7	-16.9	-12.4	-16.4	1.2	0.8	14.2	0.7	27.4
2900	10.3	-16.7	-12.2	-16.5	1.2	0.9	14.1	0.7	27.9
3000	10.1	-16.4	-12.0	-17.3	1.2	0.9	14.3	0.8	27.7
3100	9.9	-16.2	-11.8	-17.7	1.2	0.9	14.7	0.8	28.5
3200	9.6	-16.0	-11.5	-18.1	1.2	0.9	14.9	0.8	26.5
3300	9.3	-15.8	-11.1	-18.8	1.2	0.9	15.1	0.9	27.0
3400	9.1	-15.6	-10.5	-19.9	1.2	0.9	15.4	1.0	26.8
3500	8.9	-15.3	-10.3	-21.0	1.2	0.9	15.0	0.8	26.8
3600	8.8	-15.0	-10.0	-21.9	1.2	0.9	15.2	0.9	27.4
3700	8.6	-14.8	-9.8	-22.8	1.2	0.9	15.7	0.8	26.7
3800	8.4	-14.6	-9.5	-23.7	1.2	0.9	15.3	0.9	26.9
3900	8.2	-14.5	-9.2	-24.5	1.2	0.9	15.7	1.0	26.8
4000	8.0	-14.3	-9.0	-25.2	1.2	0.9	15.3	1.0	26.5

Typical Performance Data

NOTE: Use PDF Bookmarks to view DATA at required conditions

Definitions:

Input Return Loss = S11 (dB)

Gain = S21 (dB)

Isolation = S12 (dB)

Output Return Loss = S22 (dB)

TEST CONDITIONS:  $V_{DD} = +3V$ ,  $V_{SHUTDOWN} = 0V$ ,  $I_{DD} = 37mA$ ,  $I_{SHUTDOWN} = 0.0041\mu A$  @ Temperature = +25°C

FREQ	Gain	Isolation	Input Return Loss	Output Return Loss	Stability		1dB Comp. Output	Noise Figure	IP-3 Output Pout = +4
					K	Measure			
(MHz)	(dB)	(dB)	(dB)	(dB)			(dBm)	(dB)	(dBm)
10	27.7	-33.3	-6.4	-18.8	1.0	0.9	16.9	1.1	29.2
20	27.7	-33.1	-6.4	-19.5	1.0	0.9	16.0	0.5	28.3
30	27.6	-33.1	-6.4	-19.1	1.0	0.9	16.0	0.6	27.5
40	27.6	-33.2	-6.4	-18.8	1.0	0.9	15.9	0.4	27.8
50	27.6	-33.0	-6.4	-18.5	1.0	0.9	15.9	0.4	27.8
60	27.6	-33.0	-6.5	-18.2	1.0	0.9	15.9	0.5	28.2
70	27.5	-32.9	-6.5	-17.9	1.0	0.8	16.0	0.4	28.3
80	27.5	-32.8	-6.5	-17.7	1.0	0.8	16.1	0.4	28.0
90	27.5	-32.7	-6.6	-17.5	1.0	0.8	15.9	0.4	27.7
100	27.4	-32.6	-6.6	-17.2	1.0	0.8	16.0	0.4	27.4
200	26.7	-31.9	-7.2	-16.4	1.1	0.8	16.1	0.4	28.3
250	26.2	-31.5	-7.6	-16.1	1.1	0.8	15.9	0.3	27.6
300	25.7	-31.1	-7.9	-16.0	1.1	0.8	16.0	0.4	27.8
350	25.1	-30.6	-8.3	-16.0	1.1	0.8	16.1	0.4	28.3
400	24.6	-30.1	-8.7	-15.9	1.1	0.8	16.1	0.4	28.3
450	24.0	-29.5	-9.1	-15.9	1.1	0.8	15.8	0.3	28.0
500	23.5	-29.1	-9.5	-15.8	1.1	0.8	15.9	0.4	28.4
550	23.0	-28.6	-9.8	-15.8	1.1	0.8	15.9	0.4	28.6
600	22.5	-28.1	-10.1	-15.8	1.1	0.8	15.6	0.4	28.2
650	22.0	-27.6	-10.3	-15.8	1.1	0.8	15.9	0.3	28.5
700	21.5	-27.3	-10.6	-15.8	1.1	0.8	15.9	0.4	29.2
750	21.1	-26.8	-10.9	-15.8	1.1	0.8	16.0	0.4	28.6
800	20.6	-26.3	-11.1	-15.8	1.1	0.8	15.8	0.3	28.4
850	20.2	-26.0	-11.3	-15.8	1.1	0.8	15.8	0.3	29.2
900	19.8	-25.6	-11.5	-15.8	1.1	0.8	15.8	0.4	29.2
950	19.4	-25.2	-11.7	-15.8	1.1	0.8	15.9	0.4	28.6
1000	19.0	-24.9	-11.8	-15.7	1.1	0.8	15.7	0.4	29.1
1050	18.7	-24.5	-11.9	-15.7	1.1	0.8	16.1	0.4	29.3
1100	18.3	-24.2	-12.1	-15.7	1.1	0.8	15.7	0.4	29.0
1150	18.0	-23.9	-12.2	-15.7	1.1	0.8	15.7	0.4	28.6
1200	17.7	-23.5	-12.3	-15.7	1.1	0.8	15.9	0.5	29.3
1250	17.3	-23.3	-12.4	-15.6	1.1	0.8	15.9	0.4	29.2
1300	17.1	-23.0	-12.5	-15.6	1.1	0.8	16.2	0.4	28.9
1350	16.7	-22.7	-12.6	-15.6	1.1	0.8	15.6	0.4	29.4
1400	16.5	-22.4	-12.7	-15.6	1.1	0.8	15.8	0.4	29.6
1450	16.2	-22.1	-12.8	-15.5	1.1	0.8	15.9	0.4	29.3
1500	15.9	-21.9	-12.9	-15.5	1.1	0.8	16.4	0.5	29.2
1550	15.7	-21.6	-12.9	-15.4	1.1	0.8	15.7	0.5	29.7
1600	15.4	-21.4	-13.0	-15.4	1.2	0.8	15.9	0.4	29.8
1650	15.2	-21.1	-13.0	-15.4	1.2	0.8	16.2	0.5	29.0
1700	15.0	-20.9	-13.2	-15.4	1.2	0.8	15.8	0.5	29.2
1750	14.7	-20.7	-13.2	-15.3	1.2	0.8	16.1	0.5	29.4
1800	14.5	-20.5	-13.2	-15.3	1.2	0.8	16.3	0.4	29.0
1850	14.3	-20.3	-13.3	-15.3	1.2	0.8	16.0	0.5	29.2
1900	14.1	-20.1	-13.3	-15.2	1.2	0.8	16.0	0.5	29.8
1950	13.9	-19.9	-13.4	-15.2	1.2	0.8	16.2	0.4	29.8
2000	13.7	-19.7	-13.4	-15.2	1.2	0.8	16.1	0.4	29.1
2100	13.3	-19.3	-13.5	-15.2	1.2	0.8	16.2	0.5	29.8
2200	12.9	-18.9	-13.5	-15.1	1.2	0.8	16.1	0.5	29.1
2300	12.6	-18.6	-13.5	-15.0	1.2	0.8	15.7	0.5	29.3
2400	12.2	-18.3	-13.6	-15.1	1.2	0.8	16.1	0.7	29.4
2500	11.9	-18.0	-13.6	-15.1	1.2	0.8	15.9	0.6	29.1
2600	11.5	-17.7	-13.5	-15.1	1.2	0.8	15.7	0.6	29.7
2700	11.3	-17.4	-13.2	-15.7	1.2	0.8	15.6	0.6	28.9
2800	11.0	-17.1	-13.2	-15.6	1.2	0.8	14.9	0.6	29.4
2900	10.7	-16.9	-13.0	-15.7	1.2	0.8	14.7	0.7	29.8
3000	10.4	-16.6	-12.7	-16.6	1.2	0.8	15.1	0.7	29.5
3100	10.2	-16.4	-12.5	-16.8	1.2	0.8	15.5	0.7	30.4
3200	9.9	-16.2	-12.2	-17.2	1.2	0.9	15.7	0.8	28.4
3300	9.6	-16.0	-11.7	-17.9	1.2	0.9	15.8	0.9	29.1
3400	9.4	-15.8	-11.1	-18.9	1.2	0.9	16.2	0.9	28.9
3500	9.3	-15.5	-10.8	-20.0	1.2	0.9	15.7	0.8	28.8
3600	9.1	-15.2	-10.5	-20.7	1.2	0.9	16.0	0.8	29.5
3700	8.9	-15.0	-10.2	-21.6	1.2	0.9	16.4	0.8	28.7
3800	8.7	-14.8	-10.0	-22.5	1.2	0.9	16.0	0.9	28.9
3900	8.5	-14.6	-9.7	-23.4	1.2	0.9	16.4	1.0	28.7
4000	8.3	-14.5	-9.4	-24.4	1.2	0.9	15.9	0.9	28.3

Typical Performance Data

NOTE: Use PDF Bookmarks to view DATA at required conditions

Definitions:

Input Return Loss = S11 (dB)

Gain = S21 (dB)

Isolation = S12 (dB)

Output Return Loss = S22 (dB)

TEST CONDITIONS: V<sub>DD</sub> = +3.3 V, V<sub>SHUTDOWN</sub> = 0 V, I<sub>DD</sub> = 42 mA, I<sub>SHUTDOWN</sub> = 0.0041 μA @ Temperature = +25°C

FREQ	Gain	Isolation	Input Return Loss	Output Return Loss	Stability		1dB Comp. Output	Noise Figure	IP-3 Output Pout = +4
					K	Measure			
(MHz)	(dB)	(dB)	(dB)	(dB)			(dBm)	(dB)	(dBm)
10	28.1	-33.6	-6.9	-20.7	1.0	0.9	18.0	1.1	30.1
20	28.0	-33.4	-6.8	-21.4	1.0	0.9	17.2	0.4	29.6
30	28.0	-33.6	-6.8	-20.9	1.0	0.9	17.2	0.6	29.4
40	28.0	-33.3	-6.8	-20.4	1.0	0.9	17.1	0.4	29.0
50	28.0	-33.2	-6.9	-19.9	1.0	0.8	17.2	0.4	29.2
60	28.0	-33.0	-6.9	-19.5	1.0	0.8	17.0	0.4	29.7
70	27.9	-33.1	-6.9	-19.2	1.0	0.8	17.1	0.4	29.8
80	27.9	-33.0	-7.0	-18.8	1.0	0.8	17.2	0.4	29.8
90	27.8	-32.8	-7.0	-18.6	1.0	0.8	17.0	0.4	29.0
100	27.8	-32.8	-7.1	-18.3	1.0	0.8	17.1	0.4	29.1
200	27.0	-32.2	-7.6	-16.9	1.1	0.8	17.2	0.4	29.9
250	26.6	-31.7	-8.0	-16.5	1.1	0.8	17.0	0.4	29.0
300	26.0	-31.4	-8.4	-16.2	1.1	0.8	17.2	0.4	29.5
350	25.5	-30.8	-8.9	-16.0	1.1	0.8	17.2	0.3	29.9
400	24.9	-30.3	-9.2	-15.8	1.1	0.8	17.1	0.4	32.8
450	24.4	-29.9	-9.6	-15.7	1.1	0.8	16.8	0.4	30.2
500	23.8	-29.4	-10.0	-15.6	1.1	0.8	16.9	0.4	31.8
550	23.3	-28.9	-10.3	-15.6	1.1	0.8	16.9	0.4	30.2
600	22.8	-28.4	-10.7	-15.5	1.1	0.8	16.6	0.4	29.7
650	22.3	-27.9	-10.9	-15.4	1.1	0.8	16.8	0.3	30.3
700	21.8	-27.5	-11.2	-15.4	1.1	0.8	16.8	0.4	31.0
750	21.3	-27.0	-11.5	-15.3	1.1	0.8	16.9	0.3	30.6
800	20.9	-26.6	-11.7	-15.3	1.1	0.8	16.7	0.4	30.0
850	20.5	-26.2	-12.0	-15.3	1.1	0.8	16.7	0.3	31.4
900	20.1	-25.8	-12.1	-15.3	1.1	0.8	16.7	0.3	30.8
950	19.7	-25.4	-12.3	-15.3	1.1	0.8	16.7	0.4	30.6
1000	19.3	-25.1	-12.4	-15.2	1.1	0.8	16.6	0.3	31.1
1050	18.9	-24.7	-12.6	-15.2	1.1	0.8	17.0	0.4	31.4
1100	18.6	-24.4	-12.7	-15.2	1.1	0.8	16.6	0.4	30.9
1150	18.2	-24.1	-12.8	-15.1	1.1	0.8	16.5	0.4	30.6
1200	17.9	-23.8	-13.0	-15.1	1.1	0.8	16.7	0.4	31.2
1250	17.6	-23.5	-13.1	-15.1	1.1	0.8	16.8	0.4	31.3
1300	17.3	-23.2	-13.1	-15.0	1.1	0.8	17.0	0.4	30.6
1350	17.0	-22.9	-13.3	-15.0	1.1	0.8	16.4	0.4	31.4
1400	16.7	-22.6	-13.3	-15.0	1.1	0.8	16.6	0.4	31.3
1450	16.4	-22.3	-13.5	-14.9	1.1	0.8	16.7	0.4	31.2
1500	16.2	-22.1	-13.5	-14.9	1.1	0.8	17.2	0.4	31.0
1550	15.9	-21.8	-13.6	-14.8	1.1	0.8	16.5	0.4	31.6
1600	15.7	-21.6	-13.7	-14.8	1.2	0.8	16.7	0.5	31.6
1650	15.4	-21.3	-13.7	-14.8	1.1	0.8	17.0	0.5	30.9
1700	15.2	-21.1	-13.9	-14.8	1.2	0.8	16.5	0.5	31.3
1750	15.0	-20.9	-13.9	-14.7	1.2	0.8	16.9	0.4	31.6
1800	14.7	-20.7	-13.9	-14.7	1.2	0.8	17.1	0.4	30.8
1850	14.5	-20.5	-14.0	-14.7	1.2	0.8	16.8	0.5	31.2
1900	14.3	-20.3	-14.0	-14.6	1.2	0.8	16.8	0.4	31.5
1950	14.1	-20.1	-14.1	-14.6	1.2	0.8	17.0	0.4	31.8
2000	13.9	-19.9	-14.1	-14.6	1.2	0.8	16.8	0.4	31.2
2100	13.5	-19.5	-14.2	-14.6	1.2	0.8	16.9	0.5	31.2
2200	13.2	-19.1	-14.2	-14.5	1.2	0.8	16.9	0.4	31.3
2300	12.8	-18.8	-14.2	-14.4	1.2	0.8	16.4	0.5	31.0
2400	12.5	-18.4	-14.2	-14.4	1.2	0.8	16.8	0.6	31.2
2500	12.1	-18.1	-14.2	-14.5	1.2	0.8	16.6	0.5	31.0
2600	11.8	-17.9	-14.2	-14.5	1.2	0.8	16.5	0.5	31.5
2700	11.5	-17.6	-13.9	-15.1	1.2	0.8	16.3	0.6	30.8
2800	11.2	-17.3	-13.8	-15.0	1.2	0.8	15.6	0.6	31.0
2900	10.9	-17.1	-13.6	-15.1	1.2	0.8	15.4	0.6	31.6
3000	10.7	-16.8	-13.3	-15.9	1.2	0.8	15.7	0.7	30.9
3100	10.4	-16.5	-13.1	-16.1	1.2	0.8	16.1	0.7	32.3
3200	10.1	-16.4	-12.7	-16.5	1.2	0.8	16.3	0.7	30.1
3300	9.9	-16.2	-12.1	-17.2	1.2	0.9	16.5	0.8	31.2
3400	9.7	-15.9	-11.6	-18.1	1.2	0.9	16.8	0.8	30.9
3500	9.5	-15.6	-11.2	-19.1	1.2	0.9	16.4	0.8	30.2
3600	9.3	-15.4	-11.0	-19.7	1.2	0.9	16.6	0.8	31.2
3700	9.2	-15.1	-10.6	-20.6	1.2	0.9	17.0	0.8	30.2
3800	9.0	-14.9	-10.3	-21.4	1.2	0.9	16.7	0.9	30.6
3900	8.8	-14.8	-10.1	-22.3	1.2	0.9	17.1	1.1	30.3
4000	8.6	-14.6	-9.8	-23.3	1.2	0.9	16.6	0.9	29.8

Typical Performance Data

NOTE: Use PDF Bookmarks to view DATA at required conditions

Definitions:

Input Return Loss = S11 (dB)

Gain = S21 (dB)

Isolation = S12 (dB)

Output Return Loss = S22 (dB)

TEST CONDITIONS: V<sub>DD</sub> = +4.75 V, V<sub>SHUTDOWN</sub> = 0 V, I<sub>DD</sub> = 66 mA, I<sub>SHUTDOWN</sub> = 0.0037 µA @ Temperature = +25°C

FREQ	Gain	Isolation	Input Return Loss	Output Return Loss	Stability		1dB Comp. Output	Noise Figure	IP-3 Output Pout = +4
					K	Measure			
(MHz)	(dB)	(dB)	(dB)	(dB)			(dBm)	(dB)	(dBm)
10	29.3	-34.3	-8.6	-24.9	1.0	0.8	21.3	1.2	35.1
20	29.2	-33.7	-8.5	-36.4	1.0	0.8	21.2	0.4	33.6
30	29.2	-33.7	-8.6	-34.0	1.0	0.8	20.6	0.5	33.8
40	29.2	-33.7	-8.6	-30.1	1.0	0.8	20.9	0.3	32.4
50	29.2	-33.7	-8.7	-27.5	1.0	0.8	21.0	0.3	32.8
60	29.1	-33.5	-8.8	-25.6	1.0	0.8	20.8	0.4	34.6
70	29.1	-33.4	-8.8	-24.3	1.0	0.7	20.7	0.4	34.2
80	29.0	-33.3	-8.9	-23.4	1.0	0.7	20.7	0.4	33.8
90	29.0	-33.3	-8.9	-22.6	1.0	0.7	20.9	0.4	33.7
100	28.9	-33.2	-9.0	-21.9	1.0	0.7	20.7	0.3	33.3
200	28.1	-32.7	-9.7	-17.8	1.1	0.7	20.9	0.3	34.3
250	27.5	-32.4	-10.1	-16.8	1.1	0.7	20.8	0.3	32.7
300	27.0	-32.0	-10.6	-16.0	1.1	0.7	20.9	0.4	34.1
350	26.4	-31.5	-11.1	-15.4	1.1	0.7	20.6	0.3	34.8
400	25.8	-31.1	-11.5	-15.0	1.1	0.7	20.4	0.3	35.5
450	25.2	-30.5	-12.0	-14.6	1.1	0.7	20.1	0.3	34.9
500	24.6	-30.1	-12.3	-14.4	1.1	0.7	20.1	0.3	35.8
550	24.0	-29.6	-12.7	-14.1	1.2	0.7	20.0	0.4	35.1
600	23.5	-29.1	-13.1	-13.9	1.2	0.7	19.9	0.3	34.9
650	23.0	-28.6	-13.4	-13.8	1.2	0.7	19.9	0.3	35.3
700	22.5	-28.2	-13.7	-13.6	1.2	0.7	19.7	0.3	36.0
750	22.0	-27.7	-14.0	-13.5	1.2	0.7	19.7	0.3	35.1
800	21.6	-27.3	-14.2	-13.4	1.2	0.7	19.3	0.3	36.3
850	21.1	-26.8	-14.5	-13.3	1.2	0.7	19.5	0.3	36.3
900	20.7	-26.5	-14.7	-13.2	1.2	0.7	19.4	0.3	35.3
950	20.3	-26.1	-14.9	-13.1	1.2	0.7	19.5	0.3	35.7
1000	19.9	-25.7	-15.1	-13.0	1.2	0.7	20.1	0.3	36.5
1050	19.5	-25.3	-15.2	-13.0	1.2	0.7	19.3	0.3	36.5
1100	19.2	-25.0	-15.5	-12.8	1.2	0.7	19.3	0.3	36.0
1150	18.8	-24.7	-15.6	-12.8	1.2	0.7	19.2	0.3	37.1
1200	18.5	-24.3	-15.7	-12.7	1.2	0.7	19.3	0.3	37.2
1250	18.2	-24.0	-16.0	-12.7	1.2	0.7	19.3	0.4	36.7
1300	17.9	-23.7	-16.0	-12.7	1.2	0.7	19.4	0.4	36.0
1350	17.6	-23.5	-16.2	-12.5	1.2	0.7	19.4	0.3	37.2
1400	17.3	-23.1	-16.3	-12.5	1.1	0.7	19.3	0.4	37.1
1450	17.0	-22.9	-16.4	-12.4	1.2	0.7	19.6	0.3	35.8
1500	16.7	-22.6	-16.6	-12.4	1.2	0.7	19.0	0.4	37.6
1550	16.5	-22.4	-16.6	-12.4	1.2	0.7	19.6	0.4	37.1
1600	16.2	-22.1	-16.8	-12.3	1.2	0.7	19.1	0.4	36.8
1650	16.0	-21.9	-16.8	-12.3	1.2	0.7	19.3	0.4	36.0
1700	15.7	-21.7	-16.8	-12.3	1.2	0.7	19.1	0.4	38.1
1750	15.5	-21.4	-17.0	-12.3	1.2	0.7	19.1	0.4	37.9
1800	15.3	-21.2	-16.9	-12.3	1.2	0.7	19.4	0.4	36.2
1850	15.0	-21.0	-17.1	-12.2	1.2	0.7	19.2	0.4	37.7
1900	14.8	-20.8	-17.1	-12.3	1.2	0.7	19.2	0.3	37.5
1950	14.6	-20.6	-17.1	-12.2	1.2	0.7	19.3	0.4	36.8
2000	14.4	-20.4	-17.2	-12.2	1.2	0.7	19.2	0.4	35.6
2100	14.0	-20.0	-17.2	-12.2	1.2	0.7	19.1	0.4	36.0
2200	13.7	-19.6	-17.0	-12.3	1.2	0.7	19.4	0.4	36.6
2300	13.3	-19.3	-16.8	-12.3	1.2	0.8	18.9	0.4	36.2
2400	13.0	-18.9	-16.7	-12.6	1.2	0.8	18.7	0.4	36.1
2500	12.6	-18.6	-16.7	-12.7	1.2	0.8	19.2	0.4	34.9
2600	12.3	-18.3	-16.4	-12.8	1.2	0.8	19.1	0.5	36.3
2700	12.0	-18.1	-15.9	-13.2	1.2	0.8	17.9	0.5	36.2
2800	11.6	-17.8	-15.2	-13.8	1.2	0.8	17.6	0.4	35.8
2900	11.4	-17.5	-14.8	-14.4	1.2	0.8	18.4	0.6	35.6
3000	11.2	-17.2	-14.5	-14.8	1.2	0.8	18.0	0.6	35.4
3100	10.9	-17.0	-14.1	-15.4	1.2	0.8	18.1	0.8	36.1
3200	10.6	-16.8	-13.5	-16.1	1.2	0.8	19.0	0.8	34.8
3300	10.4	-16.6	-12.7	-17.2	1.2	0.8	18.8	0.8	35.2
3400	10.2	-16.3	-12.0	-18.5	1.2	0.9	18.4	0.9	35.8
3500	10.0	-16.0	-11.5	-19.7	1.2	0.9	18.5	0.8	34.1
3600	9.8	-15.8	-11.2	-20.9	1.2	0.9	18.7	0.8	34.0
3700	9.6	-15.6	-10.7	-22.3	1.2	0.9	18.6	0.8	34.9
3800	9.4	-15.4	-10.3	-24.0	1.2	0.9	18.6	0.9	33.9
3900	9.2	-15.2	-9.9	-26.0	1.2	0.9	18.4	0.9	34.9
4000	9.0	-15.0	-9.6	-28.1	1.2	0.9	18.4	0.9	33.4

Typical Performance Data

NOTE: Use PDF Bookmarks to view DATA at required conditions

Definitions:

Input Return Loss = S11 (dB)

Gain = S21 (dB)

Isolation = S12 (dB)

Output Return Loss = S22 (dB)

TEST CONDITIONS: V<sub>DD</sub> = +5 V, V<sub>SHUTDOWN</sub> = 0 V, I<sub>DD</sub> = 70 mA, I<sub>SHUTDOWN</sub> = 0.0041 μA @ Temperature = +25°C

FREQ	Gain	Isolation	Input Return Loss	Output Return Loss	Stability		1dB Comp. Output	Noise Figure	IP-3 Output Pout = +4
					K	Measure			
(MHz)	(dB)	(dB)	(dB)	(dB)			(dBm)	(dB)	(dBm)
10	29.4	-34.0	-8.7	-25.7	1.0	0.8	21.9	1.2	35.0
20	29.3	-33.9	-8.7	-40.4	1.0	0.8	21.8	0.6	33.3
30	29.3	-34.0	-8.8	-36.8	1.0	0.8	21.3	0.5	34.3
40	29.3	-33.7	-8.8	-30.9	1.0	0.8	21.5	0.4	33.3
50	29.3	-33.6	-8.9	-28.0	1.0	0.7	21.6	0.4	34.0
60	29.2	-33.6	-9.0	-25.9	1.0	0.7	21.4	0.3	35.3
70	29.2	-33.5	-9.0	-24.5	1.0	0.7	21.4	0.3	35.0
80	29.2	-33.3	-9.1	-23.5	1.0	0.7	21.4	0.4	34.4
90	29.1	-33.3	-9.1	-22.6	1.0	0.7	21.4	0.3	34.1
100	29.0	-33.3	-9.2	-21.9	1.0	0.7	21.4	0.3	34.4
200	28.2	-32.7	-9.9	-17.7	1.1	0.7	21.4	0.3	34.7
250	27.6	-32.4	-10.4	-16.7	1.1	0.7	21.3	0.3	33.2
300	27.1	-32.0	-10.8	-15.8	1.1	0.7	21.3	0.3	34.8
350	26.5	-31.6	-11.3	-15.2	1.1	0.7	21.1	0.3	35.4
400	25.8	-31.1	-11.7	-14.8	1.1	0.7	20.7	0.3	35.4
450	25.3	-30.7	-12.2	-14.4	1.1	0.7	20.5	0.3	35.1
500	24.7	-30.2	-12.6	-14.2	1.2	0.7	20.5	0.3	36.5
550	24.1	-29.7	-13.0	-13.9	1.2	0.7	20.4	0.4	35.7
600	23.6	-29.2	-13.3	-13.7	1.2	0.7	20.3	0.4	35.5
650	23.1	-28.7	-13.7	-13.6	1.2	0.7	20.3	0.3	36.7
700	22.6	-28.2	-13.9	-13.4	1.2	0.7	20.0	0.3	37.1
750	22.1	-27.8	-14.2	-13.3	1.2	0.7	20.0	0.3	35.9
800	21.6	-27.3	-14.5	-13.2	1.2	0.7	19.7	0.3	36.8
850	21.2	-26.9	-14.7	-13.1	1.2	0.7	19.9	0.3	37.6
900	20.8	-26.5	-15.0	-13.0	1.2	0.7	19.8	0.3	35.9
950	20.4	-26.1	-15.1	-12.9	1.2	0.7	19.9	0.4	36.9
1000	20.0	-25.8	-15.4	-12.8	1.2	0.7	20.4	0.4	37.3
1050	19.6	-25.4	-15.5	-12.7	1.2	0.7	19.7	0.4	37.3
1100	19.2	-25.1	-15.8	-12.6	1.2	0.7	19.6	0.4	36.8
1150	18.9	-24.7	-15.9	-12.6	1.2	0.7	19.5	0.4	37.5
1200	18.6	-24.4	-16.0	-12.5	1.2	0.7	19.6	0.4	37.5
1250	18.2	-24.1	-16.3	-12.4	1.2	0.7	19.7	0.4	37.3
1300	17.9	-23.8	-16.3	-12.4	1.2	0.7	19.7	0.4	36.8
1350	17.6	-23.5	-16.5	-12.3	1.2	0.7	19.8	0.4	37.8
1400	17.4	-23.2	-16.6	-12.3	1.2	0.7	19.7	0.4	38.1
1450	17.1	-23.0	-16.6	-12.2	1.2	0.7	19.9	0.5	37.1
1500	16.8	-22.7	-16.9	-12.2	1.2	0.7	19.3	0.4	37.9
1550	16.5	-22.5	-16.9	-12.2	1.2	0.7	20.0	0.5	37.6
1600	16.3	-22.2	-17.1	-12.1	1.2	0.7	19.4	0.5	38.2
1650	16.0	-22.0	-17.1	-12.1	1.2	0.7	19.7	0.5	36.5
1700	15.8	-21.7	-17.1	-12.0	1.2	0.7	19.5	0.5	37.8
1750	15.6	-21.5	-17.3	-12.1	1.2	0.7	19.5	0.5	38.1
1800	15.3	-21.3	-17.2	-12.1	1.2	0.7	19.7	0.5	36.6
1850	15.1	-21.1	-17.4	-12.0	1.2	0.7	19.6	0.5	38.2
1900	14.9	-20.9	-17.4	-12.0	1.2	0.7	19.5	0.5	38.4
1950	14.7	-20.7	-17.4	-12.0	1.2	0.7	19.7	0.5	37.0
2000	14.5	-20.4	-17.5	-12.0	1.2	0.7	19.5	0.5	36.7
2100	14.1	-20.1	-17.5	-12.0	1.2	0.7	19.5	0.4	36.5
2200	13.7	-19.7	-17.3	-12.1	1.2	0.7	19.7	0.4	37.3
2300	13.4	-19.3	-17.1	-12.1	1.2	0.7	19.2	0.5	36.8
2400	13.0	-19.0	-17.0	-12.3	1.2	0.8	19.0	0.5	37.0
2500	12.7	-18.7	-16.9	-12.4	1.2	0.8	19.5	0.4	35.3
2600	12.4	-18.4	-16.7	-12.5	1.2	0.8	19.5	0.5	37.1
2700	12.0	-18.1	-16.1	-12.9	1.2	0.8	18.2	0.5	36.8
2800	11.7	-17.9	-15.4	-13.5	1.2	0.8	17.9	0.5	36.7
2900	11.5	-17.6	-15.0	-14.1	1.2	0.8	18.8	0.6	35.9
3000	11.2	-17.3	-14.7	-14.5	1.2	0.8	18.3	0.6	35.9
3100	11.0	-17.1	-14.3	-15.1	1.2	0.8	18.4	0.7	36.8
3200	10.7	-16.8	-13.7	-15.7	1.2	0.8	19.4	0.7	34.7
3300	10.4	-16.6	-12.8	-16.8	1.2	0.8	19.2	0.8	35.5
3400	10.2	-16.4	-12.1	-18.0	1.2	0.9	18.8	0.9	36.1
3500	10.0	-16.1	-11.7	-19.2	1.2	0.9	18.8	1.0	34.3
3600	9.9	-15.9	-11.3	-20.3	1.2	0.9	19.0	0.8	34.1
3700	9.7	-15.6	-10.9	-21.6	1.2	0.9	19.0	0.8	35.5
3800	9.5	-15.4	-10.4	-23.2	1.2	0.9	18.9	0.8	34.1
3900	9.3	-15.3	-10.0	-25.1	1.2	0.9	18.8	0.8	35.2
4000	9.1	-15.1	-9.7	-27.1	1.2	0.9	18.8	0.9	33.6

Typical Performance Data

NOTE: Use PDF Bookmarks to view DATA at required conditions

Definitions:

Input Return Loss = S11 (dB)

Gain = S21 (dB)

Isolation = S12 (dB)

Output Return Loss = S22 (dB)

TEST CONDITIONS: V<sub>DD</sub> = +5.25 V, V<sub>SHUTDOWN</sub> = 0 V, I<sub>DD</sub> = 68 mA, I<sub>SHUTDOWN</sub> = 0.0043 μA @ Temperature = +25°C

FREQ	Gain	Isolation	Input Return Loss	Output Return Loss	Stability		1dB Comp. Output	Noise Figure	IP-3 Output Pout = +4
					K	Measure			
(MHz)	(dB)	(dB)	(dB)	(dB)			(dBm)	(dB)	(dBm)
10	29.5	-34.3	-8.9	-25.3	1.0	0.8	22.4	1.2	34.1
20	29.4	-34.1	-8.9	-42.2	1.0	0.8	22.3	0.4	34.1
30	29.4	-34.0	-9.0	-37.9	1.0	0.8	21.8	0.5	34.1
40	29.4	-33.9	-9.0	-31.2	1.0	0.8	22.0	0.4	34.1
50	29.4	-33.7	-9.1	-28.4	1.0	0.7	22.1	0.3	34.3
60	29.3	-33.7	-9.1	-26.1	1.0	0.7	21.9	0.4	35.9
70	29.3	-33.6	-9.2	-24.6	1.0	0.7	21.9	0.3	35.8
80	29.3	-33.5	-9.2	-23.6	1.0	0.7	21.9	0.4	34.8
90	29.2	-33.4	-9.3	-22.6	1.0	0.7	21.9	0.4	34.3
100	29.1	-33.3	-9.4	-21.9	1.0	0.7	21.9	0.3	35.0
200	28.3	-32.8	-10.1	-17.5	1.1	0.7	21.9	0.3	35.7
250	27.7	-32.5	-10.6	-16.5	1.1	0.7	21.8	0.3	33.7
300	27.1	-32.1	-11.0	-15.6	1.1	0.7	21.8	0.3	35.5
350	26.5	-31.7	-11.5	-15.0	1.1	0.7	21.6	0.3	35.6
400	25.9	-31.2	-11.9	-14.6	1.1	0.7	21.2	0.3	36.3
450	25.3	-30.7	-12.4	-14.2	1.2	0.7	20.9	0.3	35.6
500	24.7	-30.2	-12.8	-14.0	1.2	0.7	20.9	0.3	37.4
550	24.2	-29.7	-13.2	-13.7	1.2	0.7	20.8	0.4	35.9
600	23.6	-29.2	-13.5	-13.5	1.2	0.7	20.7	0.3	36.5
650	23.1	-28.8	-13.9	-13.4	1.2	0.7	20.7	0.3	37.4
700	22.6	-28.3	-14.2	-13.2	1.2	0.7	20.4	0.3	37.6
750	22.1	-27.9	-14.5	-13.1	1.2	0.7	20.4	0.3	36.7
800	21.7	-27.4	-14.7	-13.0	1.2	0.7	20.0	0.3	37.3
850	21.3	-27.0	-15.0	-12.9	1.2	0.7	20.3	0.3	38.2
900	20.8	-26.6	-15.3	-12.8	1.2	0.7	20.2	0.3	36.8
950	20.4	-26.2	-15.4	-12.7	1.2	0.7	20.2	0.3	37.1
1000	20.0	-25.8	-15.6	-12.6	1.2	0.7	20.7	0.3	37.5
1050	19.7	-25.5	-15.7	-12.6	1.2	0.7	20.0	0.3	38.0
1100	19.3	-25.2	-16.0	-12.4	1.2	0.7	20.0	0.3	36.6
1150	19.0	-24.8	-16.2	-12.4	1.2	0.7	19.8	0.3	38.5
1200	18.6	-24.5	-16.3	-12.3	1.2	0.7	19.9	0.4	38.2
1250	18.3	-24.2	-16.5	-12.3	1.2	0.7	20.0	0.3	38.0
1300	18.0	-23.9	-16.5	-12.3	1.2	0.7	20.1	0.4	37.3
1350	17.7	-23.6	-16.8	-12.1	1.2	0.7	20.1	0.4	38.1
1400	17.4	-23.3	-16.9	-12.1	1.2	0.7	20.0	0.4	38.2
1450	17.1	-23.0	-16.9	-12.0	1.2	0.7	20.2	0.4	37.1
1500	16.9	-22.8	-17.2	-12.0	1.2	0.7	19.7	0.4	38.3
1550	16.6	-22.5	-17.1	-12.0	1.2	0.7	20.3	0.4	37.5
1600	16.3	-22.3	-17.3	-11.9	1.2	0.7	19.8	0.4	38.3
1650	16.1	-22.1	-17.4	-11.9	1.2	0.7	20.0	0.4	36.9
1700	15.8	-21.8	-17.4	-11.9	1.2	0.7	19.8	0.4	39.1
1750	15.6	-21.6	-17.6	-11.9	1.2	0.7	19.8	0.4	38.3
1800	15.4	-21.4	-17.4	-11.9	1.2	0.7	20.1	0.3	37.4
1850	15.2	-21.1	-17.7	-11.8	1.2	0.7	19.9	0.3	38.4
1900	14.9	-20.9	-17.6	-11.9	1.2	0.7	19.8	0.4	38.4
1950	14.7	-20.7	-17.7	-11.8	1.2	0.7	20.0	0.4	37.4
2000	14.5	-20.5	-17.8	-11.8	1.2	0.7	19.8	0.4	36.5
2100	14.1	-20.2	-17.8	-11.8	1.2	0.7	19.8	0.5	36.6
2200	13.8	-19.8	-17.5	-11.9	1.2	0.7	20.1	0.4	37.7
2300	13.4	-19.4	-17.3	-11.9	1.2	0.7	19.6	0.4	36.8
2400	13.1	-19.1	-17.2	-12.2	1.2	0.7	19.3	0.5	36.7
2500	12.8	-18.8	-17.2	-12.2	1.2	0.7	19.9	0.5	35.3
2600	12.4	-18.5	-16.9	-12.3	1.2	0.8	19.8	0.4	37.8
2700	12.1	-18.2	-16.3	-12.7	1.2	0.8	18.5	0.5	36.7
2800	11.7	-18.0	-15.7	-13.3	1.2	0.8	18.2	0.5	36.5
2900	11.6	-17.6	-15.2	-13.9	1.2	0.8	19.1	0.6	36.0
3000	11.3	-17.4	-14.9	-14.3	1.2	0.8	18.6	0.6	35.9
3100	11.0	-17.1	-14.5	-14.8	1.2	0.8	18.7	0.7	37.1
3200	10.8	-16.9	-13.8	-15.4	1.2	0.8	19.7	0.8	35.3
3300	10.5	-16.7	-13.0	-16.5	1.2	0.8	19.5	0.9	36.0
3400	10.3	-16.5	-12.2	-17.7	1.2	0.9	19.1	0.9	36.1
3500	10.1	-16.2	-11.8	-18.8	1.2	0.9	19.1	0.9	34.1
3600	9.9	-15.9	-11.4	-19.8	1.2	0.9	19.3	0.8	34.5
3700	9.7	-15.7	-11.0	-21.0	1.2	0.9	19.3	0.9	35.4
3800	9.6	-15.5	-10.5	-22.5	1.2	0.9	19.2	0.9	34.4
3900	9.4	-15.3	-10.1	-24.3	1.2	0.9	19.1	1.0	35.4
4000	9.2	-15.2	-9.8	-26.2	1.2	0.9	19.1	0.9	33.5

Typical Performance Data

NOTE: Use PDF Bookmarks to view DATA at required conditions

Definitions:

Input Return Loss = S11 (dB)

Gain = S21 (dB)

Isolation = S12 (dB)

Output Return Loss = S22 (dB)

TEST CONDITIONS: V<sub>DD</sub> = +5 V, V<sub>SHUTDOWN</sub> = 0 V, I<sub>DD</sub> = 71 mA, I<sub>SHUTDOWN</sub> = 0.0054 μA @ Temperature = -45°C

FREQ	Gain	Isolation	Input Return Loss	Output Return Loss	Stability		1dB Comp. Output	Noise Figure	IP-3 Output Pout = +4
					K	Measure			
(MHz)	(dB)	(dB)	(dB)	(dB)			(dBm)	(dB)	(dBm)
10	29.9	-34.0	-10.1	-24.1	1.0	0.7	22.3	1.5	30.2
20	29.9	-34.1	-9.8	-25.7	1.0	0.7	22.1	0.4	37.0
30	29.9	-34.4	-9.9	-26.0	1.0	0.8	21.4	0.5	35.7
40	29.9	-34.3	-9.9	-25.5	1.0	0.7	21.6	0.3	35.1
50	29.9	-34.1	-10.0	-24.8	1.0	0.7	21.7	0.3	34.5
60	29.8	-34.0	-10.0	-23.9	1.0	0.7	21.5	0.3	36.0
70	29.8	-34.0	-10.1	-23.1	1.0	0.7	21.5	0.3	36.1
80	29.7	-33.9	-10.2	-22.3	1.0	0.7	21.5	0.3	35.1
90	29.7	-33.8	-10.2	-21.7	1.0	0.7	21.5	0.3	34.5
100	29.6	-33.7	-10.3	-21.0	1.0	0.7	21.5	0.3	35.4
200	28.7	-33.2	-11.0	-17.1	1.1	0.7	21.6	0.3	35.8
250	28.2	-32.9	-11.5	-16.1	1.1	0.7	21.6	0.2	34.1
300	27.6	-32.5	-12.0	-15.3	1.1	0.7	21.7	0.2	35.9
350	26.9	-32.0	-12.5	-14.7	1.1	0.7	21.6	0.3	36.3
400	26.3	-31.5	-12.9	-14.3	1.1	0.7	21.5	0.2	37.1
450	25.7	-31.0	-13.4	-13.9	1.2	0.7	21.2	0.2	37.1
500	25.1	-30.5	-13.8	-13.6	1.2	0.7	21.0	0.3	37.9
550	24.5	-30.0	-14.2	-13.3	1.2	0.7	21.2	0.3	37.0
600	24.0	-29.5	-14.6	-13.2	1.2	0.7	21.1	0.2	36.8
650	23.5	-29.0	-14.9	-13.0	1.1	0.7	21.0	0.2	38.1
700	23.0	-28.5	-15.2	-12.9	1.1	0.7	20.8	0.2	38.1
750	22.5	-28.0	-15.5	-12.8	1.1	0.7	20.8	0.2	37.0
800	22.0	-27.6	-15.7	-12.7	1.1	0.7	20.4	0.2	37.3
850	21.6	-27.1	-16.0	-12.6	1.1	0.7	20.6	0.2	38.4
900	21.2	-26.7	-16.3	-12.5	1.1	0.7	20.4	0.2	36.5
950	20.8	-26.4	-16.4	-12.4	1.1	0.7	20.6	0.2	38.4
1000	20.4	-26.0	-16.7	-12.4	1.1	0.7	21.2	0.2	38.0
1050	20.0	-25.6	-16.7	-12.3	1.1	0.7	20.3	0.2	38.3
1100	19.6	-25.3	-17.0	-12.2	1.1	0.7	20.3	0.2	38.0
1150	19.3	-24.9	-17.1	-12.2	1.1	0.7	20.1	0.2	39.1
1200	19.0	-24.6	-17.3	-12.1	1.1	0.7	20.3	0.3	38.4
1250	18.6	-24.3	-17.5	-12.1	1.1	0.7	20.3	0.3	38.3
1300	18.3	-24.0	-17.5	-12.1	1.1	0.7	20.4	0.2	39.3
1350	18.0	-23.7	-17.7	-12.0	1.1	0.7	20.4	0.3	38.2
1400	17.7	-23.4	-17.8	-12.0	1.1	0.7	20.3	0.3	39.1
1450	17.4	-23.1	-17.9	-11.9	1.1	0.7	20.5	0.3	38.8
1500	17.2	-22.9	-18.1	-11.9	1.1	0.7	19.9	0.3	40.5
1550	16.9	-22.6	-18.1	-11.8	1.1	0.7	20.6	0.2	38.6
1600	16.6	-22.3	-18.3	-11.8	1.1	0.7	20.0	0.2	39.5
1650	16.4	-22.1	-18.3	-11.8	1.1	0.7	20.2	0.2	39.4
1700	16.1	-21.9	-18.3	-11.7	1.1	0.7	20.0	0.3	39.5
1750	15.9	-21.6	-18.5	-11.7	1.1	0.7	20.0	0.4	39.0
1800	15.7	-21.4	-18.5	-11.6	1.1	0.7	20.3	0.3	38.7
1850	15.5	-21.2	-18.6	-11.6	1.1	0.7	20.1	0.3	40.1
1900	15.2	-21.0	-18.6	-11.6	1.1	0.7	20.0	0.3	40.3
1950	15.0	-20.8	-18.6	-11.6	1.1	0.7	20.2	0.4	39.3
2000	14.8	-20.6	-18.7	-11.6	1.1	0.7	19.9	0.3	39.0
2100	14.4	-20.2	-18.7	-11.5	1.1	0.7	20.0	0.3	38.7
2200	14.1	-19.8	-18.5	-11.5	1.1	0.7	20.2	0.3	38.0
2300	13.7	-19.4	-18.4	-11.6	1.1	0.7	19.6	0.2	38.7
2400	13.3	-19.1	-18.2	-11.8	1.1	0.7	19.5	0.3	37.6
2500	13.0	-18.8	-17.9	-11.9	1.1	0.7	19.7	0.3	38.2
2600	12.7	-18.5	-17.5	-12.1	1.1	0.7	19.8	0.4	38.5
2700	12.4	-18.2	-17.1	-12.3	1.1	0.7	18.7	0.4	38.3
2800	12.0	-17.9	-16.5	-12.8	1.2	0.8	18.8	0.4	38.9
2900	11.8	-17.6	-15.9	-13.6	1.1	0.8	19.0	0.5	38.5
3000	11.6	-17.3	-15.5	-13.7	1.1	0.8	18.8	0.4	37.5
3100	11.3	-17.1	-14.9	-14.4	1.2	0.8	18.9	0.5	39.1
3200	11.0	-16.9	-14.2	-15.1	1.2	0.8	19.7	0.5	36.7
3300	10.8	-16.7	-13.3	-16.2	1.2	0.8	19.5	0.6	37.6
3400	10.6	-16.4	-12.4	-17.4	1.2	0.8	19.1	0.6	38.1
3500	10.4	-16.1	-11.8	-18.5	1.1	0.8	19.1	0.6	36.2
3600	10.2	-15.9	-11.4	-19.5	1.1	0.8	19.3	0.6	36.3
3700	10.0	-15.7	-10.9	-20.9	1.1	0.8	19.3	0.6	37.3
3800	9.8	-15.5	-10.5	-22.5	1.1	0.9	19.2	0.6	35.9
3900	9.6	-15.3	-10.1	-24.3	1.1	0.9	19.1	0.6	37.0
4000	9.5	-15.1	-9.7	-26.1	1.1	0.9	19.1	0.6	35.8

Typical Performance Data

NOTE: Use PDF Bookmarks to view DATA at required conditions

Definitions:

Input Return Loss = S11 (dB)

Gain = S21 (dB)

Isolation = S12 (dB)

Output Return Loss = S22 (dB)

TEST CONDITIONS: V<sub>DD</sub> = +5 V, V<sub>SHUTDOWN</sub> = 0 V, I<sub>DD</sub> = 72 mA, I<sub>SHUTDOWN</sub> = 0.0014 μA @ Temperature = 105°C

FREQ	Gain	Isolation	Input Return Loss	Output Return Loss	Stability		1dB Comp. Output	Noise Figure	IP-3 Output Pout = +4
					K	Measure			
(MHz)	(dB)	(dB)	(dB)	(dB)			(dBm)	(dB)	(dBm)
10	28.9	-33.5	-7.9	-22.2	1.0	0.8	21.0	1.3	34.2
20	28.8	-33.4	-8.0	-25.4	1.0	0.8	21.1	0.6	34.3
30	28.8	-33.5	-8.0	-25.0	1.0	0.8	20.6	0.7	33.7
40	28.8	-33.4	-8.1	-24.1	1.0	0.8	20.9	0.5	32.9
50	28.8	-33.4	-8.2	-23.1	1.0	0.8	21.1	0.4	33.7
60	28.7	-33.1	-8.2	-22.3	1.0	0.7	21.0	0.5	34.6
70	28.7	-33.1	-8.3	-21.6	1.0	0.7	20.9	0.5	34.6
80	28.6	-33.1	-8.3	-21.0	1.0	0.7	21.0	0.5	34.2
90	28.6	-33.0	-8.4	-20.5	1.0	0.7	21.0	0.5	33.8
100	28.5	-32.9	-8.4	-20.1	1.0	0.7	21.1	0.5	34.0
200	27.7	-32.4	-9.2	-16.9	1.1	0.7	20.9	0.5	34.7
250	27.2	-32.1	-9.6	-16.2	1.1	0.7	20.8	0.4	33.3
300	26.6	-31.7	-10.0	-15.4	1.1	0.7	20.7	0.5	34.7
350	26.0	-31.3	-10.5	-14.9	1.1	0.7	20.3	0.5	36.5
400	25.4	-30.9	-10.9	-14.6	1.1	0.7	20.1	0.4	35.7
450	24.9	-30.4	-11.4	-14.2	1.1	0.7	19.8	0.4	37.4
500	24.3	-29.9	-11.8	-14.0	1.2	0.7	19.7	0.5	38.8
550	23.8	-29.5	-12.1	-13.7	1.2	0.7	19.7	0.6	36.5
600	23.2	-29.0	-12.5	-13.6	1.2	0.7	19.6	0.5	36.2
650	22.7	-28.5	-12.8	-13.5	1.2	0.7	19.6	0.5	37.7
700	22.2	-28.1	-13.1	-13.3	1.2	0.7	19.4	0.5	38.5
750	21.8	-27.7	-13.4	-13.2	1.2	0.7	19.4	0.5	36.6
800	21.3	-27.2	-13.6	-13.1	1.2	0.7	19.0	0.5	37.0
850	20.9	-26.8	-13.9	-13.0	1.2	0.7	19.2	0.5	39.7
900	20.5	-26.4	-14.1	-13.0	1.2	0.7	19.1	0.5	37.1
950	20.1	-26.1	-14.3	-12.8	1.2	0.7	19.2	0.5	36.7
1000	19.7	-25.7	-14.5	-12.8	1.2	0.8	19.7	0.5	37.5
1050	19.3	-25.4	-14.6	-12.7	1.2	0.8	19.0	0.5	38.4
1100	19.0	-25.0	-14.8	-12.7	1.2	0.8	19.0	0.6	36.5
1150	18.6	-24.7	-15.0	-12.7	1.2	0.8	18.8	0.5	37.0
1200	18.3	-24.4	-15.1	-12.5	1.2	0.8	19.0	0.6	37.9
1250	18.0	-24.1	-15.3	-12.6	1.2	0.8	19.0	0.6	38.0
1300	17.7	-23.8	-15.4	-12.5	1.2	0.8	19.1	0.6	36.1
1350	17.4	-23.5	-15.5	-12.4	1.2	0.8	19.1	0.6	37.7
1400	17.1	-23.2	-15.7	-12.4	1.2	0.8	19.0	0.6	37.4
1450	16.8	-23.0	-15.7	-12.3	1.2	0.8	19.2	0.7	36.5
1500	16.5	-22.7	-15.9	-12.3	1.2	0.8	18.7	0.6	37.4
1550	16.3	-22.5	-15.9	-12.3	1.2	0.8	19.3	0.6	37.7
1600	16.0	-22.2	-16.1	-12.2	1.2	0.8	18.8	0.6	38.1
1650	15.7	-22.0	-16.1	-12.3	1.2	0.8	19.0	0.6	36.1
1700	15.5	-21.8	-16.1	-12.1	1.2	0.8	18.9	0.6	38.1
1750	15.3	-21.5	-16.3	-12.2	1.2	0.8	18.8	0.7	37.7
1800	15.0	-21.3	-16.2	-12.2	1.2	0.8	19.1	0.6	36.7
1850	14.8	-21.1	-16.4	-12.1	1.2	0.8	18.9	0.7	37.2
1900	14.6	-20.9	-16.4	-12.2	1.2	0.8	18.8	0.7	37.6
1950	14.4	-20.7	-16.3	-12.1	1.2	0.8	19.0	0.6	36.8
2000	14.2	-20.5	-16.4	-12.1	1.2	0.8	18.8	0.6	35.2
2100	13.8	-20.1	-16.4	-12.1	1.2	0.8	18.8	0.7	36.5
2200	13.4	-19.7	-16.3	-12.1	1.2	0.8	19.0	0.7	36.5
2300	13.1	-19.4	-16.2	-12.2	1.2	0.8	18.5	0.7	36.2
2400	12.7	-19.1	-16.0	-12.4	1.2	0.8	18.4	0.7	36.3
2500	12.4	-18.8	-15.9	-12.5	1.2	0.8	18.7	0.7	34.3
2600	12.1	-18.4	-15.7	-12.7	1.2	0.8	18.6	0.8	35.9
2700	11.8	-18.2	-15.3	-12.9	1.2	0.8	17.6	0.8	35.3
2800	11.4	-17.9	-14.8	-13.6	1.2	0.8	17.5	0.9	34.4
2900	11.2	-17.6	-14.4	-14.1	1.2	0.8	18.2	0.9	34.9
3000	10.9	-17.4	-14.1	-14.4	1.2	0.8	17.7	1.0	34.0
3100	10.7	-17.1	-13.7	-15.1	1.2	0.8	17.8	1.0	35.4
3200	10.4	-16.9	-13.2	-15.8	1.2	0.8	18.6	1.1	33.9
3300	10.1	-16.7	-12.4	-16.9	1.2	0.9	18.4	1.2	34.4
3400	9.9	-16.4	-11.8	-18.0	1.2	0.9	18.0	1.2	34.8
3500	9.7	-16.2	-11.4	-19.0	1.2	0.9	18.0	1.1	32.9
3600	9.6	-15.9	-11.0	-19.9	1.2	0.9	18.2	1.1	33.4
3700	9.4	-15.7	-10.6	-21.1	1.2	0.9	18.2	1.1	34.0
3800	9.2	-15.5	-10.2	-22.7	1.2	0.9	18.1	1.2	33.1
3900	9.0	-15.3	-9.8	-24.3	1.2	0.9	18.0	1.3	33.9
4000	8.8	-15.2	-9.5	-25.6	1.2	0.9	18.0	1.2	32.4

## Typical Performance Curves

Note: All data taken at nominal condition  $V_{DD} = +5\text{ V}$  and  $V_{SHUTDOWN} = 0\text{ V}$  unless noted otherwise.

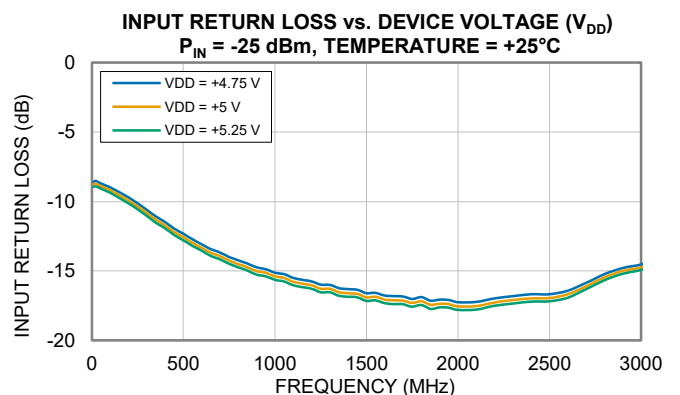
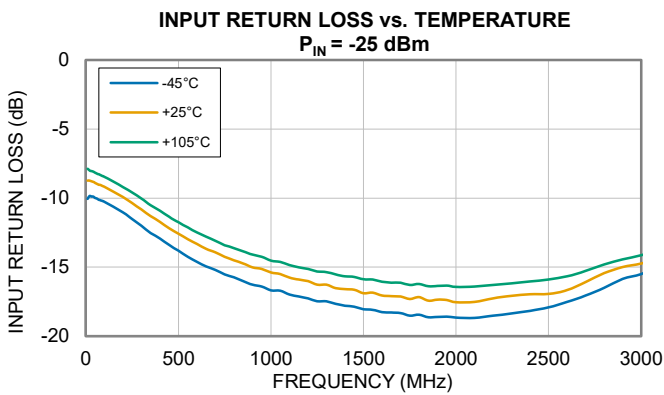
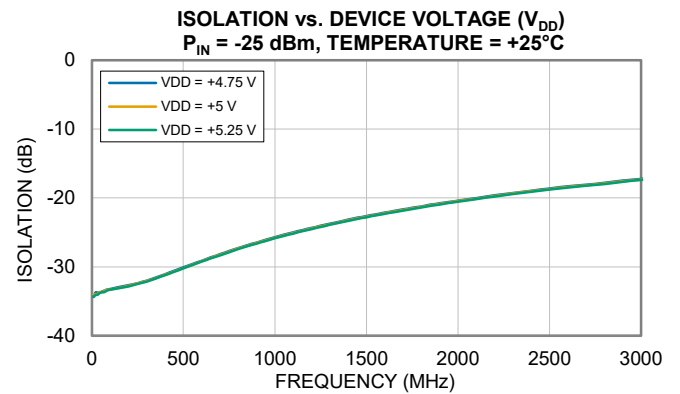
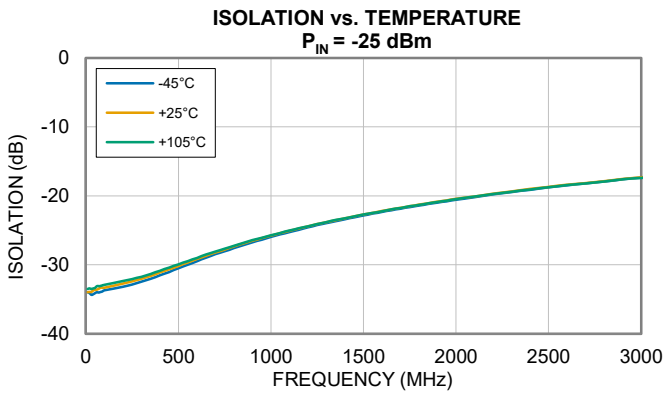
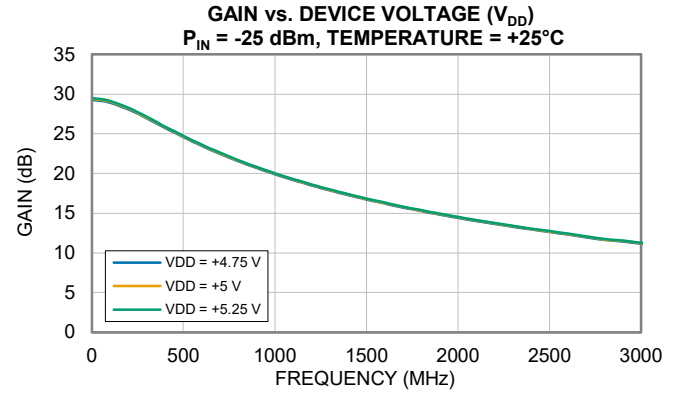
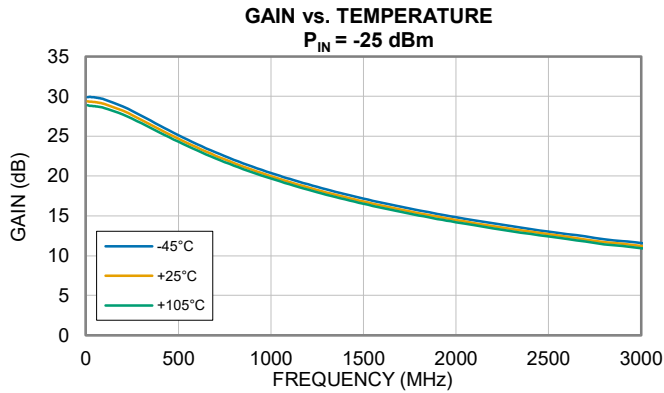

## Typical Performance Curves

Note: All data taken at nominal condition  $V_{DD} = +5\text{ V}$  and  $V_{SHUTDOWN} = 0\text{ V}$  unless noted otherwise.

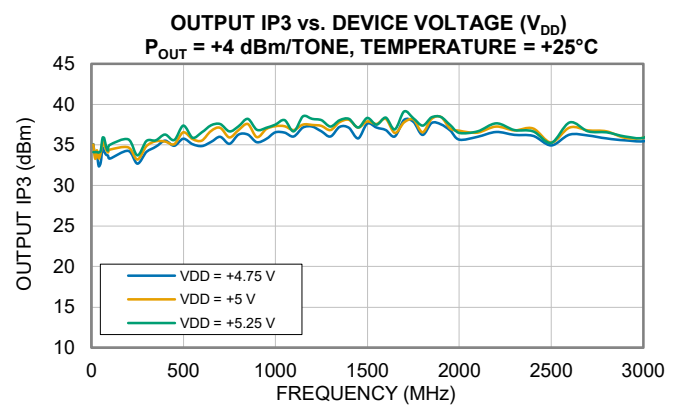
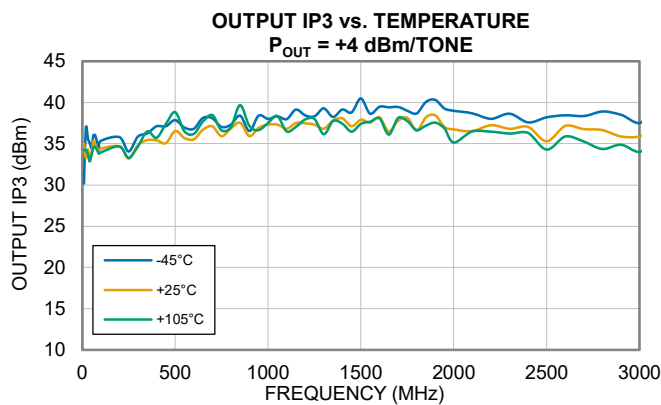
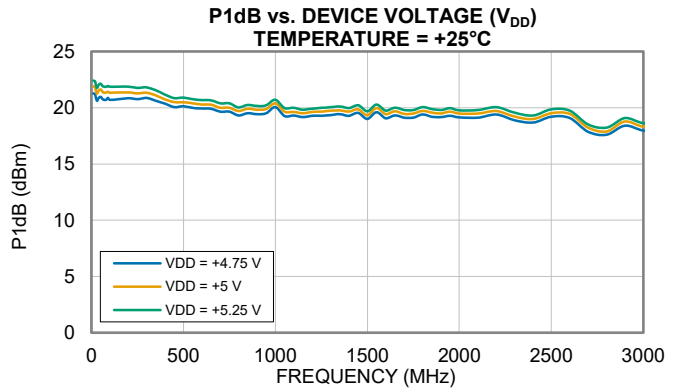
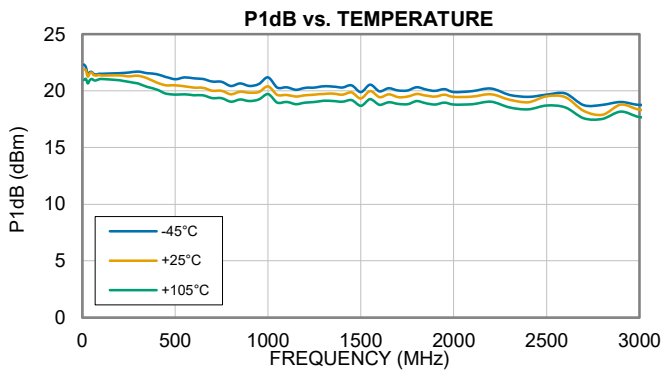
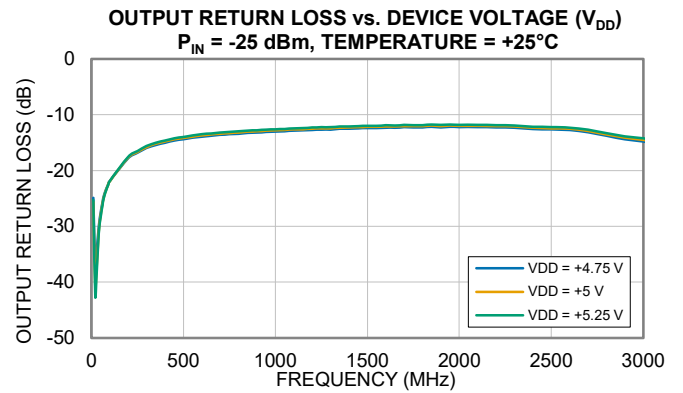
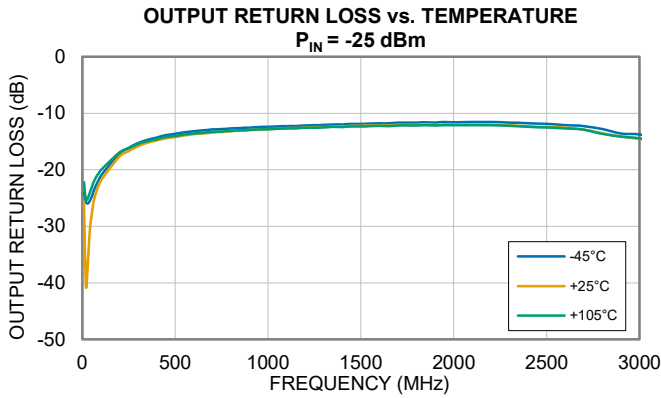

## Typical Performance Curves

Note: All data taken at nominal condition  $V_{DD} = +5\text{ V}$  and  $V_{SHUTDOWN} = 0\text{ V}$  unless noted otherwise.

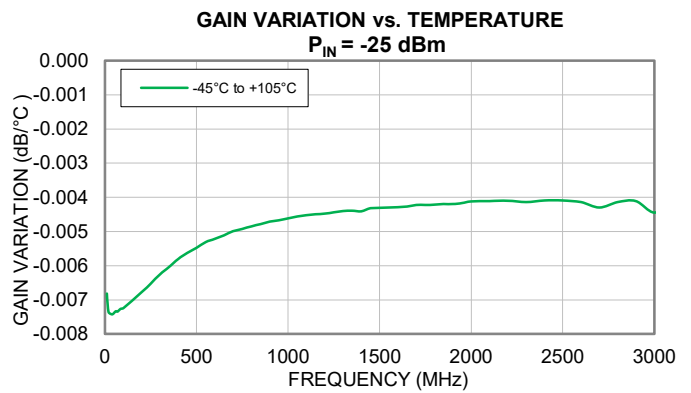
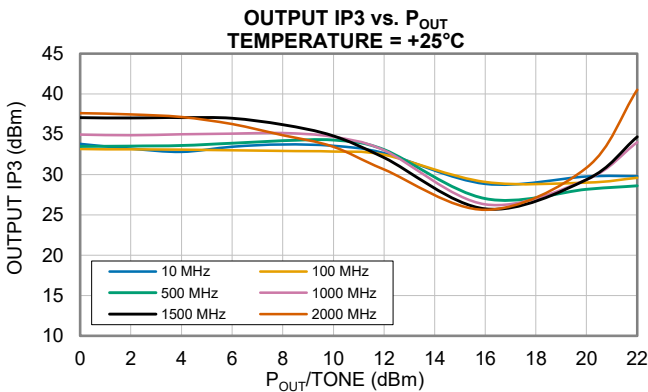
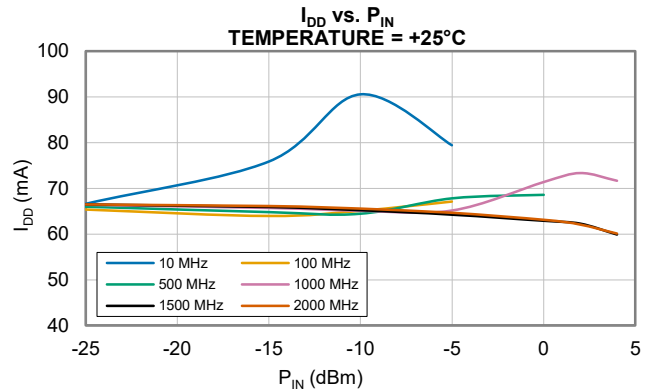
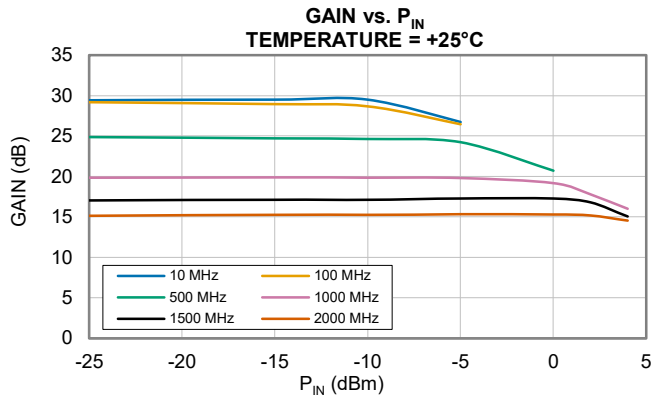
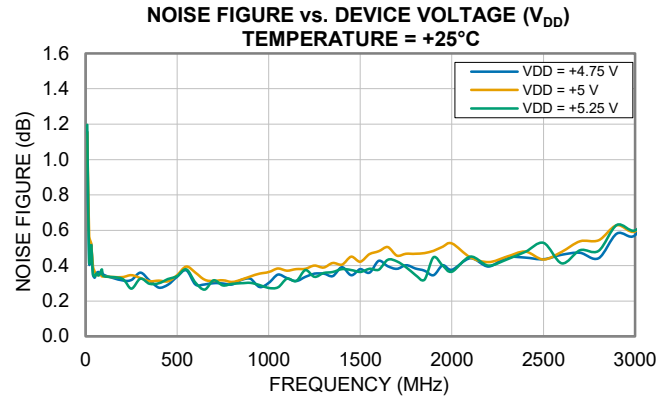
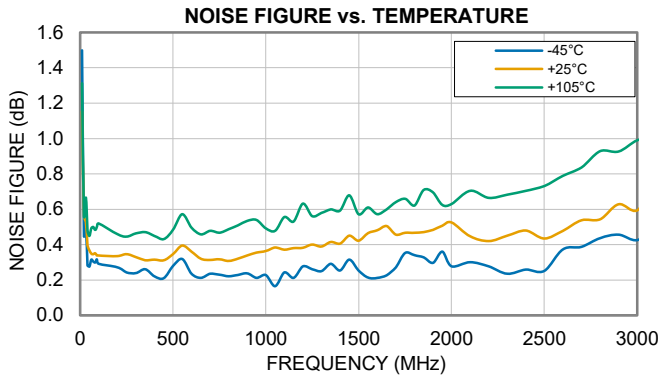

## Typical Performance Curves

Note: All data taken at nominal condition  $V_{SHUTDOWN} = 0$  V unless noted otherwise.

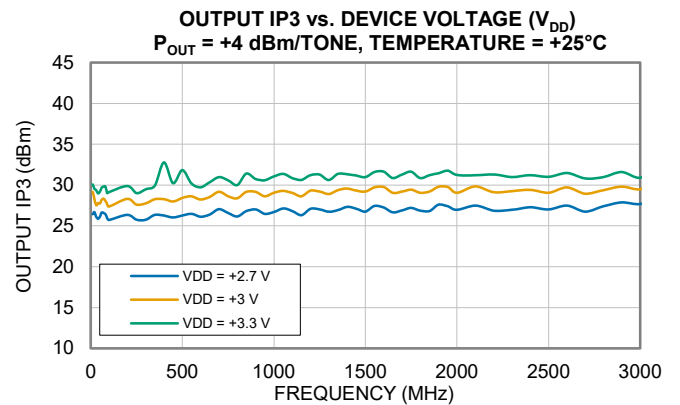
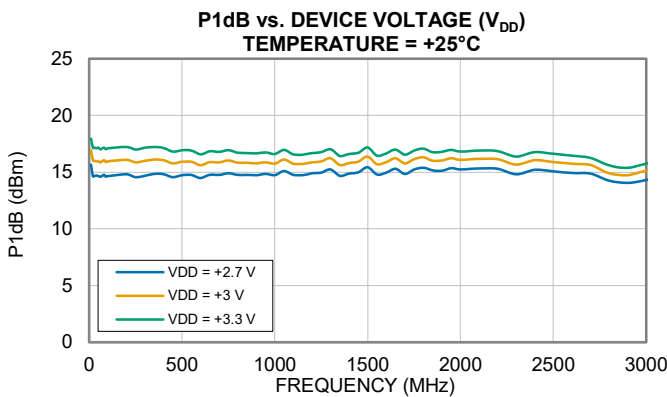
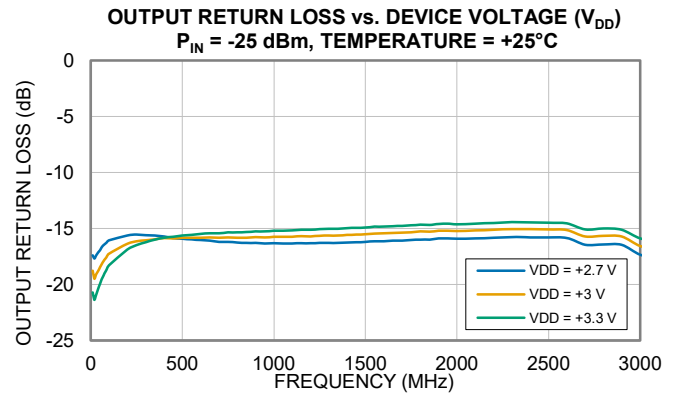
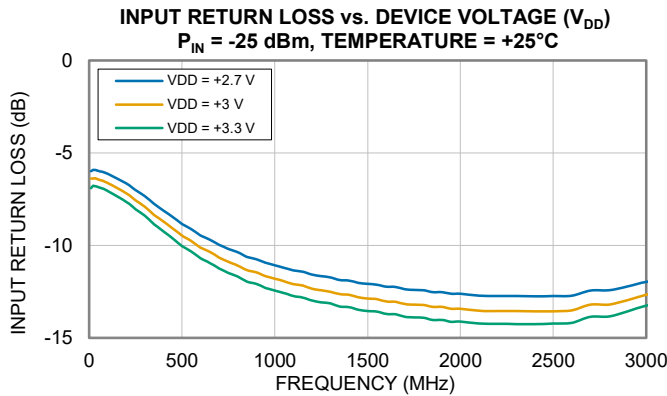
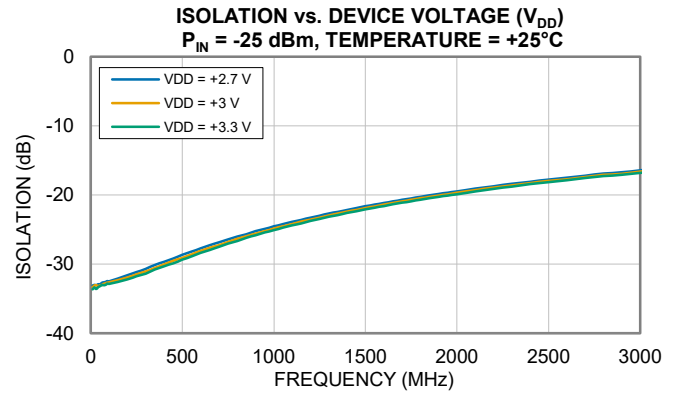
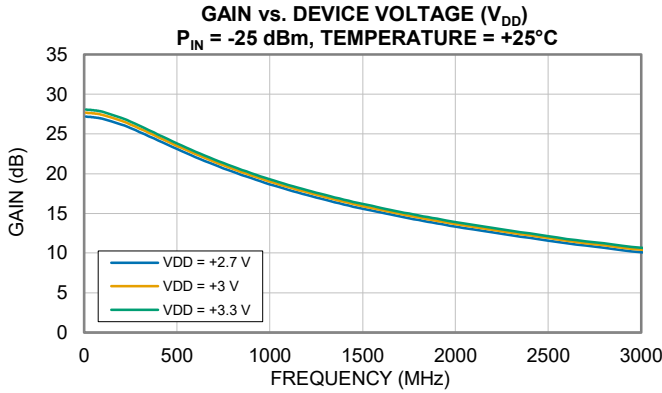

## Typical Performance Curves

Note: All data taken at nominal condition  $V_{SHUTDOWN} = 0$  V unless noted otherwise.

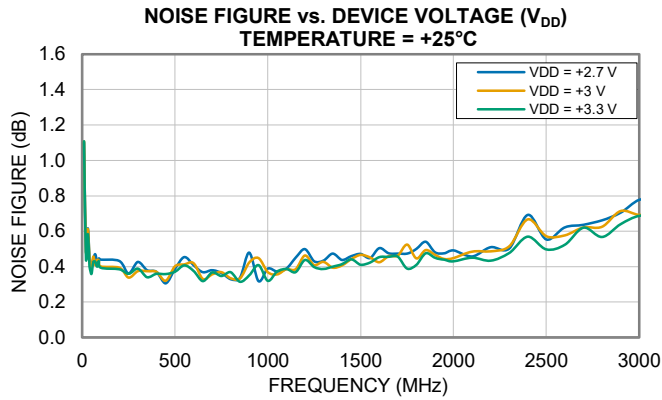

### Outline Dimensions

### PCB Land Pattern

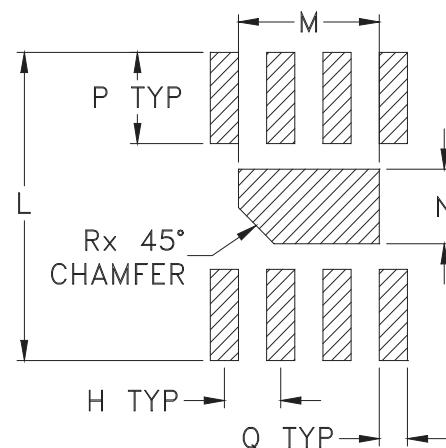
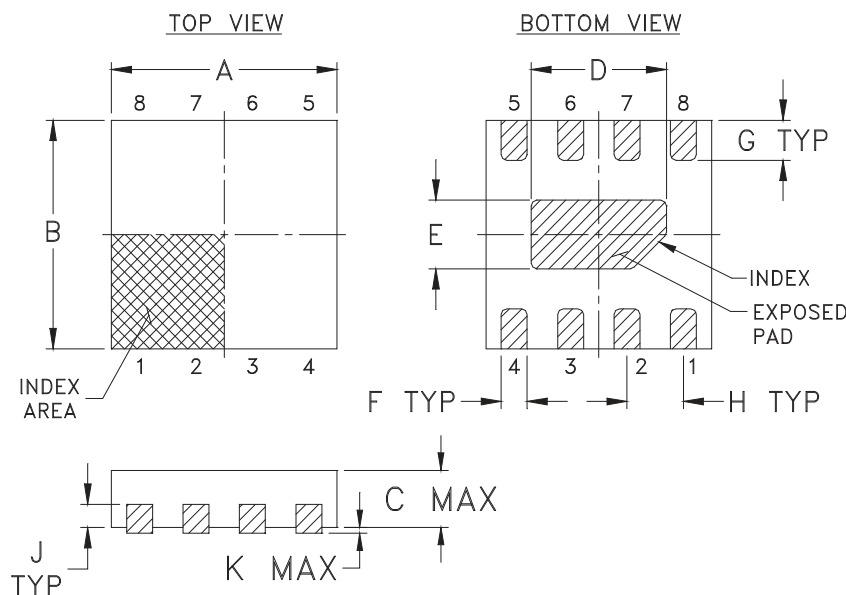

Suggested Layout,  
Tolerance to be within  $\pm .002$

SE #.	A	B	C	D	E	F	G	H	J	K	L	M	N	P
MC1631-1	.079 (2.00)	.079 (2.00)	.039 (1.00)	.047 (1.20)	.024 (.60)	.009 (.23)	.014 (.35)	.020 (.50)	.008 (.20)	.002 (.05)	.106 (2.70)	.049 (1.25)	.026 (.65)	.031 (.80)

CASE #.	Q	R	WT, GRAM
MC1631-1	.010 (.25)	.012 (.30)	.006

Dimensions are in inches (mm). Tolerances: 2 Pl.  $\pm .01$ ; 3 Pl.  $\pm .005$

#### Notes:

- Case material: Plastic.
- Termination finish:  
For RoHS Case Styles: Tin-Silver over Nickel plated or Matte-Tin Plated (See Data sheet).  
All models, (+) suffix.
- Lead #1 identifier shall be located in the cross-hatched area shown.  
Identifier may be either a molded or marked feature.

# Tape & Reel Packaging TR-F66

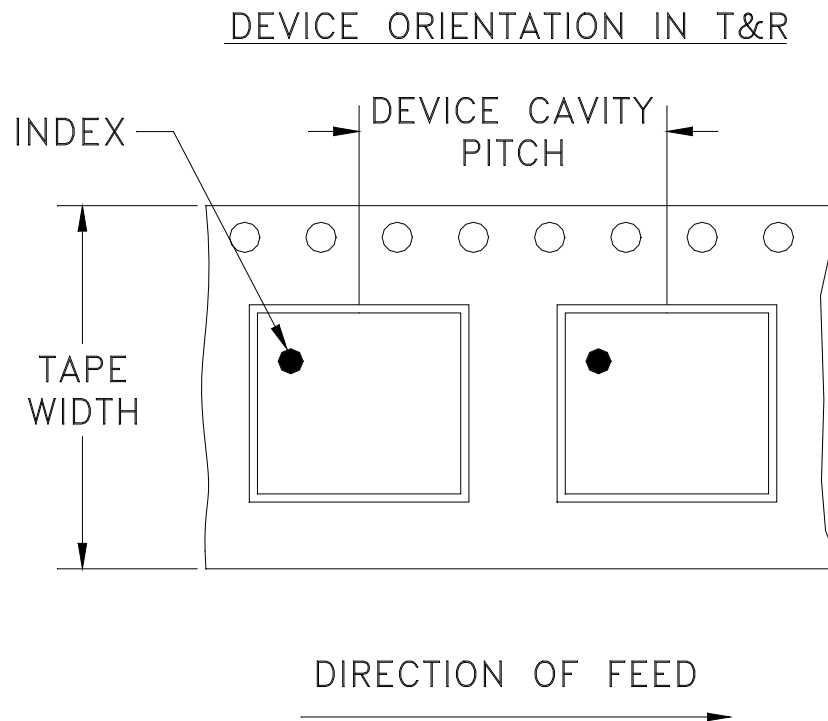

Tape Width, mm	Device Cavity Pitch, mm	Reel Size, inches	Devices per Reel see note	
8	4	7	Small quantity standard	20
				50
				100
				200
				500
		7	Standard	1000, 2000, 3000

Note: Please consult individual model data sheet to determine device per reel availability.

Mini-Circuits carrier tape materials provide protection from ESD (Electro-Static Discharge) during handling and transportation. Tapes are static dissipative and comply with industry standards EIA-481/EIA-541.

Go to: [www.minicircuits.com/pages/pdfs/tape.pdf](http://www.minicircuits.com/pages/pdfs/tape.pdf)

**Mini-Circuits®**

INTERNET <http://www.minicircuits.com>

P.O. Box 350166, Brooklyn, New York 11235-0003 (718) 934-4500 Fax (718) 332-4661

Distribution Centers NORTH AMERICA 800-654-7949 • 417-335-5935 • Fax 417-335-5945 • EUROPE 44-1252-832600 • Fax 44-1252-837010

Mini-Circuits ISO 9001 & ISO 14001 Certified

THIRD ANGLE PROJECTION

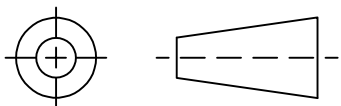

REVISIONS

REV	ECN No.	DESCRIPTION	DATE	DR	AUTH
OR	ECO-024615	NEW RELEASE	03/15/25	ITG	IL

SUGGESTED MOUNTING CONFIGURATION FOR MC1631-1 CASE STYLE

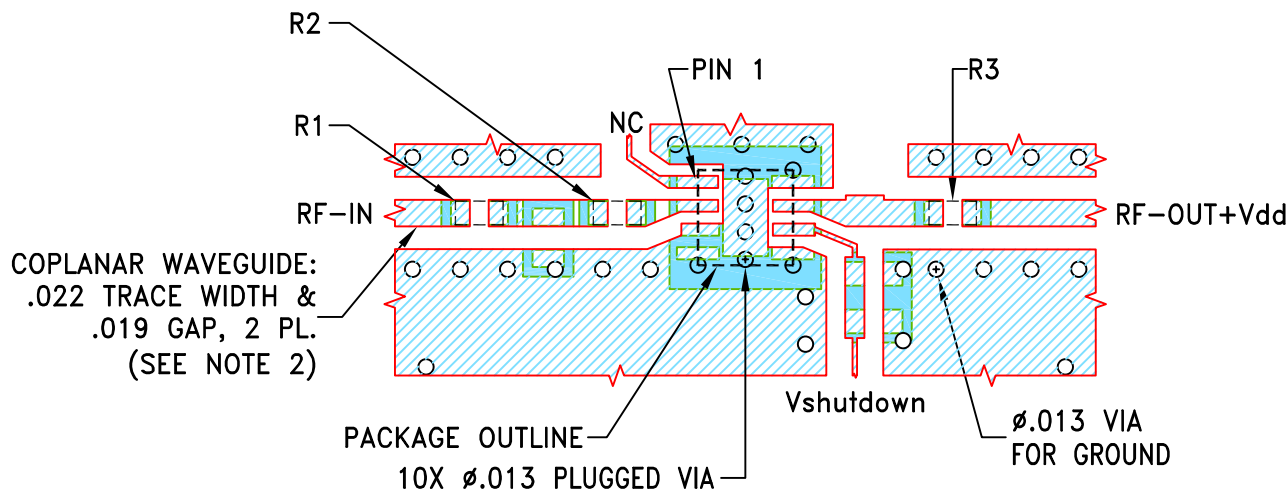

3 LAYER STACK-UP DETAIL

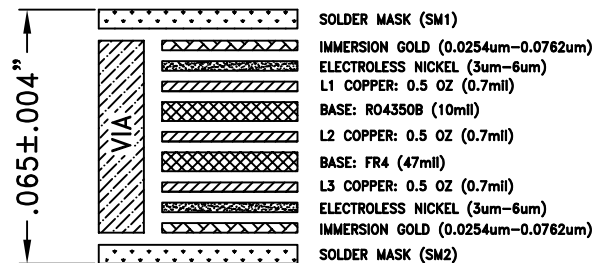

COMPONENT	SIZE
R1-R3	0402

NOTES:

1. PCB IS MULTILAYER PCB, SEE STACK-UP DIAGRAM.
2. TRACE WIDTH & GAP ARE SHOWN FOR ROGERS RO4350B WITH DIELECTRIC THICKNESS .010".  
COPPER: 1/2 OZ. EACH LAYER. FOR OTHER MATERIALS TRACE WIDTH & GAP MAY NEED TO BE MODIFIED.
3. CHIP COMPONENT FOOT PRINTS SHOWN FOR REFERENCE, FOR COMPONENT VALUES REFER TO TB-TSS-23ULNC+.
4. LAYERS 2 & 3 OF PCB ARE CONTINUOUS GROUND PLANE.
5. UNIT LAND PATTERN WAS OPTIMIZED FOR BETTER PERFORMANCE.

- DENOTES PCB COPPER LAYOUT WITH SMOBC (SOLDER MASK OVER BARE COPPER).
- DENOTES COPPER LAND PATTERN FREE OF SOLDER MASK.

UNLESS OTHERWISE SPECIFIED	INITIALS	DATE
DIMENSIONS ARE IN INCHES	ITG	02/25/25
TOLERANCES ON:	GF	02/25/25
2 PL DECIMALS ±	IL	02/25/25
3 PL DECIMALS ± .005		
ANGLES ±		
FRACTIONS ±		

**Mini-Circuits<sup>®</sup>** 13 Neptune Avenue  
Brooklyn NY 11235

PL, MC1631-1, TB-TSS-23ULNC+

SIZE A	CODE IDENT 15542	DRAWING NO: 98-PL-815	REV: OR
FILE: 98PL815	SCALE: 6:1	SHEET: 1 OF 1	

Mini-Circuits<sup>®</sup>  
THIS DOCUMENT AND ITS CONTENTS ARE THE PROPERTY OF MINI-CIRCUITS. EXCEPT FOR USE EXPRESSLY GRANTED, IN WRITING, TO ITS VENDORS, VENDEE AND THE UNITED STATES GOVERNMENT, MINI-CIRCUITS RESERVES ALL PROPRIETARY DESIGN, USE, MANUFACTURING AND REPRODUCTION RIGHTS THERETO. THESE CONTENTS SHALL NOT BE USED, DUPLICATED OR DISCLOSED TO ANY OUTSIDE PARTY, IN WHOLE OR IN PART, WITHOUT WRITTEN PERMISSION OF MINI-CIRCUITS.

# Evaluation Board and Circuit

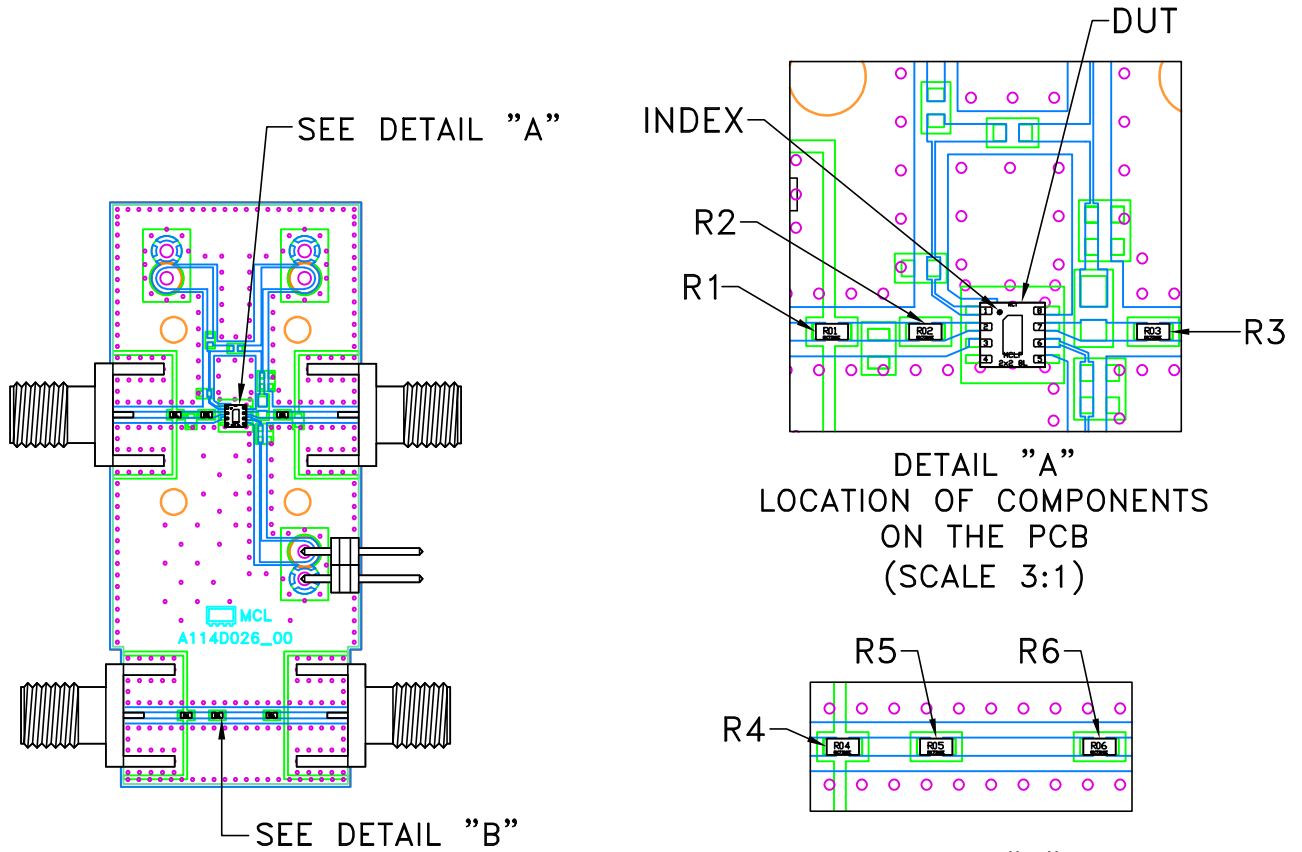

DETAIL "A"  
LOCATION OF COMPONENTS  
ON THE PCB  
(SCALE 3:1)

DETAIL "B"  
LOCATION OF COMPONENTS  
ON THE PCB  
(SCALE 3:1)

DETAIL "A"

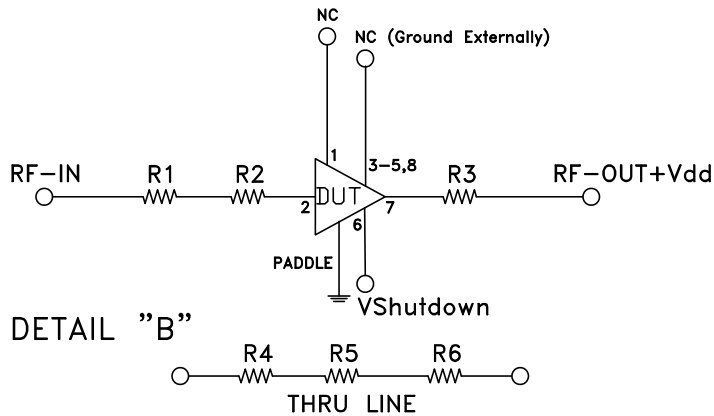

DETAIL "B"

SCHEMATIC DIAGRAM

Component	Size	Value	Part Number	Manufacturer
R1,R2,R3,R4,R5,R6	0402	00hm	RK73Z1ETTP	KOA Speer

## NOTES:

- 50 Ohm SMA Female Connectors.
- PCB Material: Roger RO4350B or equivalent, Dielectric constant=3.5, Thickness=0.010 inch

 **Mini-Circuits®**

All Mini-Circuits products are manufactured under exacting quality assurance and control standards, and are capable of meeting published specifications after being subjected to any or all of the following physical and environmental test.

Specification	Test/Inspection Condition	Reference/Spec
Operating Temperature	-40° to 85° C or -45° to 85° C or -55° to 105° C or -40° to 105° C or -40° to 95° C Ambient Environment	Individual Model Data Sheet
Storage Temperature	-55° to 100° C or -65° to 150° Ambient Environment	Individual Model Data Sheet
HTOL	1000 hours at 125°C	MIL-STD-883, Method 1005, Condition B
Thermal Shock	-55° to 100°C, 100 cycles	MIL-STD-202, Method 107, Condition A-3, except +100°C
Mechanical Shock	1.5Kg, 0.5 ms, 5 shock pulses, Y1 direction only	MIL-STD-883, Method 2002, Condition B, except Y1 direction only
Vibration (Variable Frequency)	50g peak	MIL-STD-883, Method 2007, Condition B
Autoclave	15 psig, 100% RH, 121°C, 96 hours	JESD22-A102, Condition C
HAST	130°C, 85% RH, 96 hours	JESD22-A110
Solderability	10X Magnification	J-STD-002, Para 4.2.5, Test S, 95% Coverage
Solder Reflow Heat	Sn-Pb Eutetic Process: 240°C peak Pb-Free Process: 260°C peak	J-STD-020, Table 4-1, 4-2 and 5-2; Figure 5-1
Moisture Sensitivity: Level 1	Bake at 125°C for 24 hours Soak at 85°C/85% RH for 168 hours, Reflow 3 cycles at 260°C peak	J-STD-020

All Mini-Circuits products are manufactured under exacting quality assurance and control standards, and are capable of meeting published specifications after being subjected to any or all of the following physical and environmental test.

Specification	Test/Inspection Condition	Reference/Spec
Marking Resistance to Solvents	Isopropyl alcohol + mineral spirits at 25°C; terpene defluxer at 25°C; distilled water + proylene glycol monomethyl ether + monoethanolamine at 63°C to 70°C	MIL-STD-202, Method 215