

Balanced  **RF Transformer**

**TRS2-1T-75-1+**

75Ω      5 to 1200 MHz

**The Big Deal**

- Low insertion loss, 1.0 dB typ.
- Good return loss, 20 dB typ.
- Low amplitude unbalance, 0.3 dB
- Power handling up to 0.25W



CASE STYLE: TT1618

**Product Overview**

The TRS2-1T-75-1+ is a 75Ω surface mount balanced-to-balanced transformer with a 2:1 secondary/primary impedance ratio covering the 5 to 1200 MHz band, meeting bandwidth requirements for DOCSIS® 3.1 compliant systems and equipment, among other applications. This model handles RF input power up to 0.25W and provides low insertion loss, good return loss and low amplitude unbalance. Measuring only 0.28 x 0.25 x 0.12”, the unit features core and wire, all-welded construction with gold over nickel plate wraparound terminations suitable for tin/lead and RoHS solder systems. The unit also includes Mini-Circuits’ Top Hat™ feature for faster more accurate pick-and-place assembly.

**Key Features**

Feature	Advantages
Wideband, 5 to 1200 MHz	TRS2-1T-75-1+ supports a variety of applications including CATV and DOCSIS 3.1 systems and equipment.
Low insertion loss, 1.0 dB	Enables excellent signal power transmission from input to output.
Good return loss, 20 dB typ.	Excellent matching for 75Ω systems with minimal signal reflection.
Low amplitude unbalance, 0.3 dB	Low unbalance can improve a system’s electromagnetic compatibility by rejecting unwanted common-mode noise.
Small footprint, 0.28 x 0.25”	Accommodates tight space requirements for dense PCB layouts.
Top Hat® feature	Improves speed and accuracy of pick and place assembly and provides clear device marking for visual inspection

top hat®  
Balanced  
**RF Transformer**

75Ω 5 to 1200 MHz

**TRS2-1T-75-1+**

**Features**

- suitable for tin/lead and RoHS solder systems
- wideband, 5 to 1200 MHz
- balanced transmission line
- good return loss, 20 dB typ. at 1 dB band
- excellent amplitude unbalance, 0.3 dB typ.
- aqueous washable

**Applications**

- balanced to unbalanced transformation
- push-pull amplifiers
- PCS/DCS
- cable TV
- cellular



Generic photo used for illustration purposes only  
CASE STYLE: TT1618

**+RoHS Compliant**  
The +Suffix identifies RoHS Compliance. See our web site for RoHS Compliance methodologies and qualifications

**Available Tape and Reel at no extra cost**

Reel Size	Devices/Reel
7"	10, 20, 50, 100, 200
13"	500

**Electrical Specifications at 25°C**

Parameter	Frequency (MHz)	Min.	Typ.	Max.	Unit
Impedance Ratio (secondary/primary)			2		
Frequency Range		5		1200	MHz
Insertion Loss*	5 - 600	—	0.6	1.0	dB
	600 - 1000	—	1.0	1.8	
	1000 - 1200	—	1.3	2.2	
Amplitude Unbalance	5 - 600	—	0.3	1.0	dB
	600 - 1000	—	0.6	1.7	
	1000 - 1200	—	0.8	1.9	
Phase Unbalance	5 - 50	—	0.8	3	Degree
	50 - 1200	—	5	9	
Primary Return Loss (Input)	5 - 50	17	22	—	dB
	50 - 1000	13	22	—	
	1000 - 1200	9	17	—	

\* Insertion Loss is referenced to mid-band loss, 0.6 dB typ.

**Maximum Ratings**

Parameter	Ratings
Operating Temperature	-40°C to 85°C
Storage Temperature	-55°C to 100°C
RF Power	0.25W
DC Current	30mA

Permanent damage may occur if any of these limits are exceeded.

**Pin Connections**

Function	Pin Number
PRIMARY DOT	1
PRIMARY (GROUND)	4
SECONDARY DOT	3
SECONDARY	2

Qorvo Part No.	Description
QPA4425	1218 MHz MMIC, CATV Push Pull, 25 dB Amplifier
QPA4428	1218 MHz MMIC, CATV Push Pull, 28 dB Amplifier
QPB8858	47-1218 MHz 34 dB CATV Push Pull Amplifier
QPB8857	47-1218 MHz, 28 dB CATV Doubler Amplifier
QPB8957	47-1000 MHz 28 dB CATV Doubler Amplifier
QPB8958	47-1000 MHz, 34 dB CATV Push Pull Amplifier

**Config. P1**

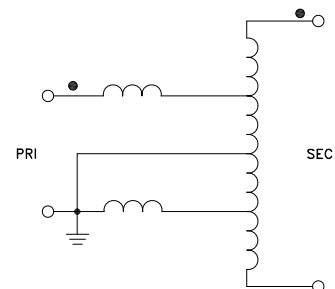

## Outline Drawing

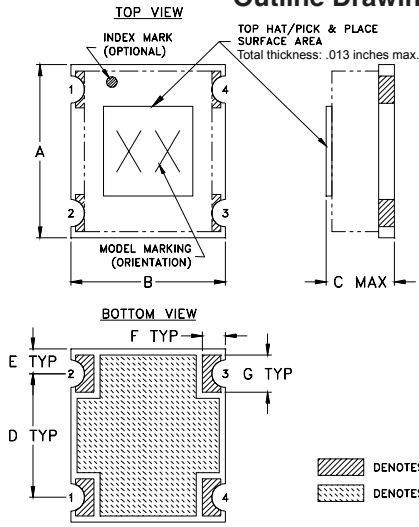

## PCB Land Pattern

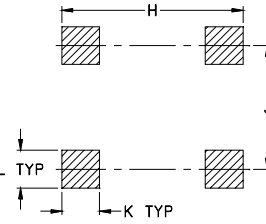

Suggested Layout,  
Tolerance to be within  $\pm .002$

## Demo Board MCL P/N: TB-619+ Suggested PCB Layout (PL-237)

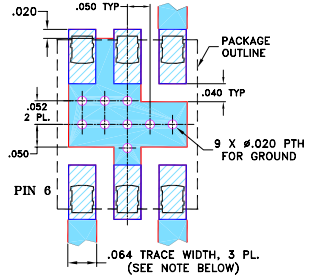

- NOTES: 1. TRACE WIDTH IS SHOWN FOR ROGERS RO4350B WITH DIELECTRIC THICKNESS .030"  $\pm$  .002"; COPPER: 1/2 OZ. EACH SIDE. FOR OTHER MATERIALS TRACE WIDTH MAY NEED TO BE MODIFIED.  
2. BOTTOM SIDE OF THE PCB IS CONTINUOUS GROUND PLANE.
- DENOTES PCB COPPER LAYOUT WITH SMOBC (SOLDER MASK OVER BARE COPPER)
  - DENOTES COPPER LAND PATTERN FREE OF SOLDER MASK

## Outline Dimensions (inch / mm)

A	B	C	D	E	F
.280	.250	.12	.200	.040	.037
7.11	6.35	3.05	5.08	1.02	0.94
G	H	J	K	L	wt.
.060	.293	.200	.061	.061	grams
1.52	7.44	5.08	1.55	1.55	2.8

## Typical Performance Data

FREQUENCY (MHz)	INSERTION LOSS (dB)	INPUT R. LOSS (dB)	AMPLITUDE UNBALANCE (dB)	PHASE UNBALANCE (Deg.)
5.00	0.76	20.46	0.16	0.07
100.00	0.72	23.43	0.13	1.58
200.00	0.77	24.55	0.11	2.85
400.00	0.87	27.39	0.15	4.61
500.00	0.94	29.37	0.20	5.13
600.00	1.02	30.97	0.27	5.43
700.00	1.11	29.50	0.37	5.60
800.00	1.21	26.22	0.45	5.67
1000.00	1.45	20.59	0.62	5.26
1200.00	1.75	16.81	0.70	4.30

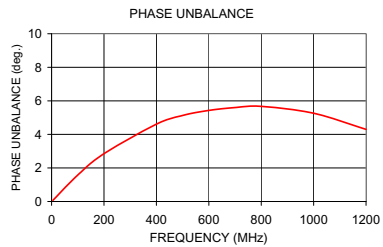
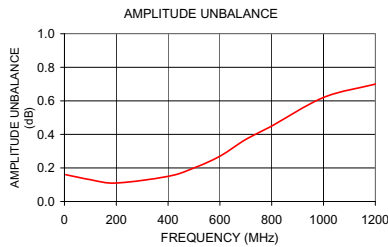
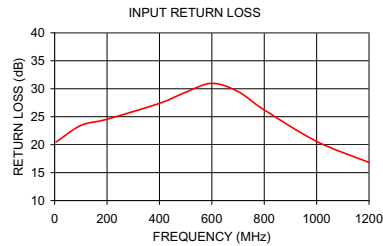

# RF Transformer

# TRS2-1T-75-1+

## Typical Performance Data

FREQUENCY MHz	AVERAGE INSERTION LOSS (dB)	INPUT RETURN LOSS (dB)	AMPLITUDE UNBALANCE (dB)	PHASE UNBALANCE (deg.)
0.5	1.88	10.45	0.15	0.27
0.6	1.70	11.35	0.16	0.21
0.7	1.56	12.12	0.17	0.21
0.8	1.46	12.77	0.16	0.14
1.0	1.31	13.83	0.16	0.09
3.0	0.86	18.67	0.16	0.01
5.0	0.76	20.46	0.16	0.07
7.0	0.73	21.33	0.16	0.13
10	0.71	21.96	0.16	0.18
30	0.70	22.69	0.15	0.53
50	0.70	22.99	0.15	0.86
70	0.71	23.20	0.14	1.17
100	0.72	23.43	0.13	1.58
150	0.74	24.05	0.13	2.23
200	0.77	24.55	0.11	2.85
250	0.79	25.15	0.11	3.39
300	0.81	25.54	0.12	3.84
350	0.84	26.47	0.13	4.24
400	0.87	27.39	0.15	4.61
450	0.90	28.27	0.17	4.88
500	0.94	29.37	0.20	5.13
550	0.98	30.09	0.23	5.28
600	1.02	30.97	0.27	5.43
650	1.07	30.16	0.32	5.52
700	1.11	29.50	0.37	5.60
750	1.16	27.89	0.41	5.72
800	1.21	26.22	0.45	5.67
850	1.26	24.85	0.50	5.66
900	1.33	23.16	0.53	5.56
950	1.38	22.01	0.58	5.42
1000	1.45	20.59	0.62	5.26
1050	1.52	19.63	0.65	5.12
1100	1.59	18.54	0.68	4.86
1150	1.67	17.62	0.69	4.60
1200	1.75	16.81	0.70	4.30
1250	1.84	15.96	0.69	3.87
1300	1.93	15.37	0.68	3.36
1400	2.13	14.08	0.60	2.19



P.O. Box 350166, Brooklyn, New York 11235-0003 (718) 934-4500 • Fax (718) 332-4661 For detailed performance specs & shopping online see Mini-Circuits web site  
The Design Engineers Search Engine Provides ACTUAL Data Instantly From MINI-CIRCUITS At: [www.minicircuits.com](http://www.minicircuits.com)



IF/RF MICROWAVE COMPONENTS

REV. OR  
TRS2-1T-75-1+  
10/26/2020  
Page 1 of 1

## Typical Performance Data

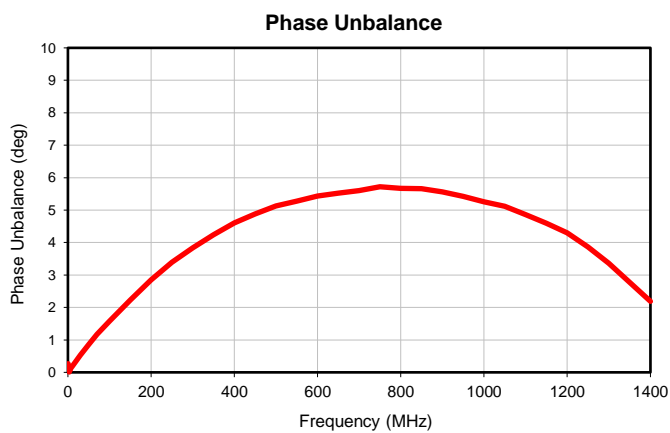
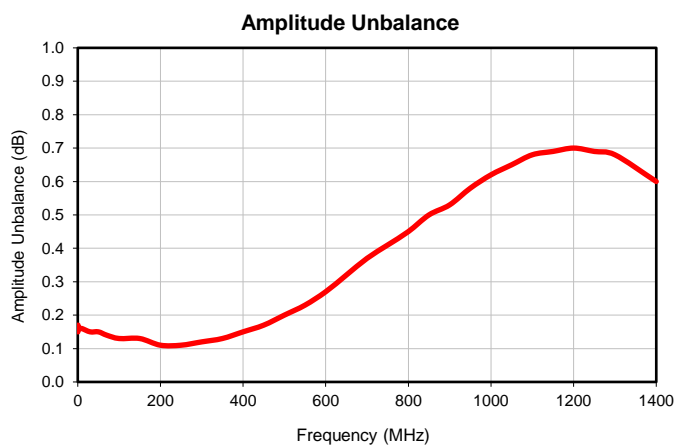
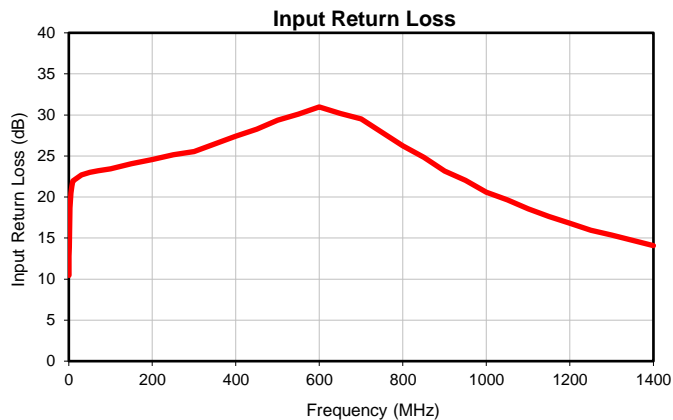
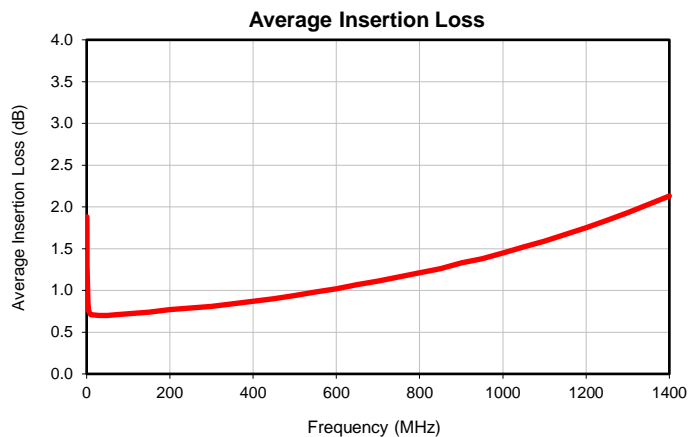

## Outline Dimensions

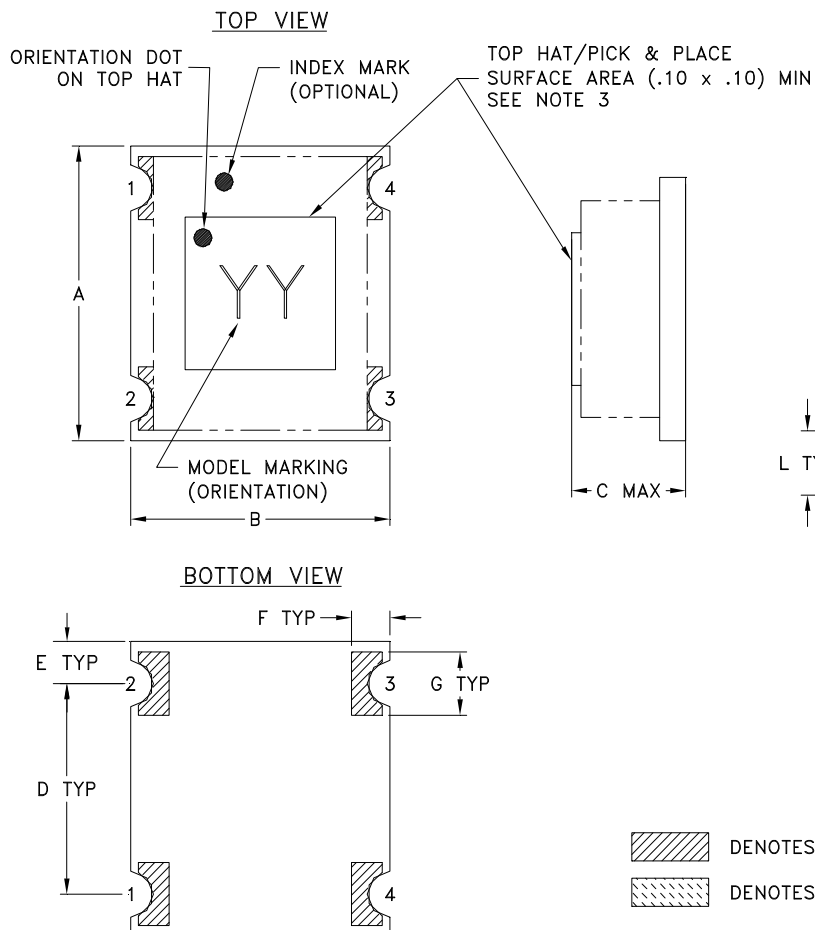

TT1618

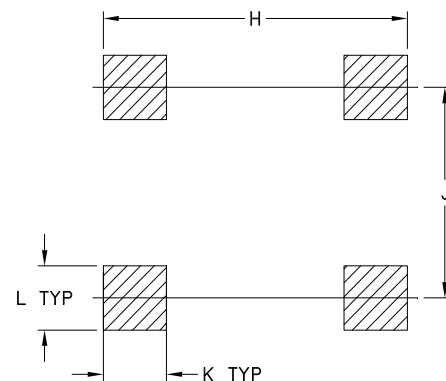

## PCB Land Pattern



SUGGESTED LAYOUT  
TOLERANCE TO BE WITHIN  $\pm 0.02$

 DENOTES METALLIZATION  
 DENOTES SOLDER RESIST

CASE #	A	B	C	D	E	F	G	H	J	K	L	WT GRAMS
TT1618	.280 (7.11)	.250 (6.35)	.12 (3.05)	.200 (5.08)	.040 (1.02)	.037 (.94)	.060 (1.52)	.293 (7.44)	.200 (5.08)	.061 (1.55)	.061 (1.55)	2.80

Dimensions are in inches (mm). Tolerances: 2Pl.  $\pm .01$ ; 3 Pl.  $\pm .005$

### Notes:

1. Open style, Base material: Printed wiring laminate.
2. Termination finish: 3-5  $\mu$  inch (.08-.13 microns) Gold over 120-240  $\mu$  inch (3.05-6.10 microns) Nickel plate.  
All models, (+) suffix.
3. Top-Hat total thickness: .013 inches MAX.
4. Orientation Dot on Top Hat & PCB corresponds to Pin #1.

  
ISO 9001 ISO 14001 CERTIFIED

ALL NEW  



P.O. Box 350166, Brooklyn, New York 11235-0003 (718) 934-4500 Fax (718) 332-4661 For detailed performance specs & shopping online see Mini-Circuits web site



The Design Engineers Search Engine Provides ACTUAL Data Instantly From MINI-CIRCUITS At: [www.minicircuits.com](http://www.minicircuits.com)

RF/IF MICROWAVE COMPONENTS

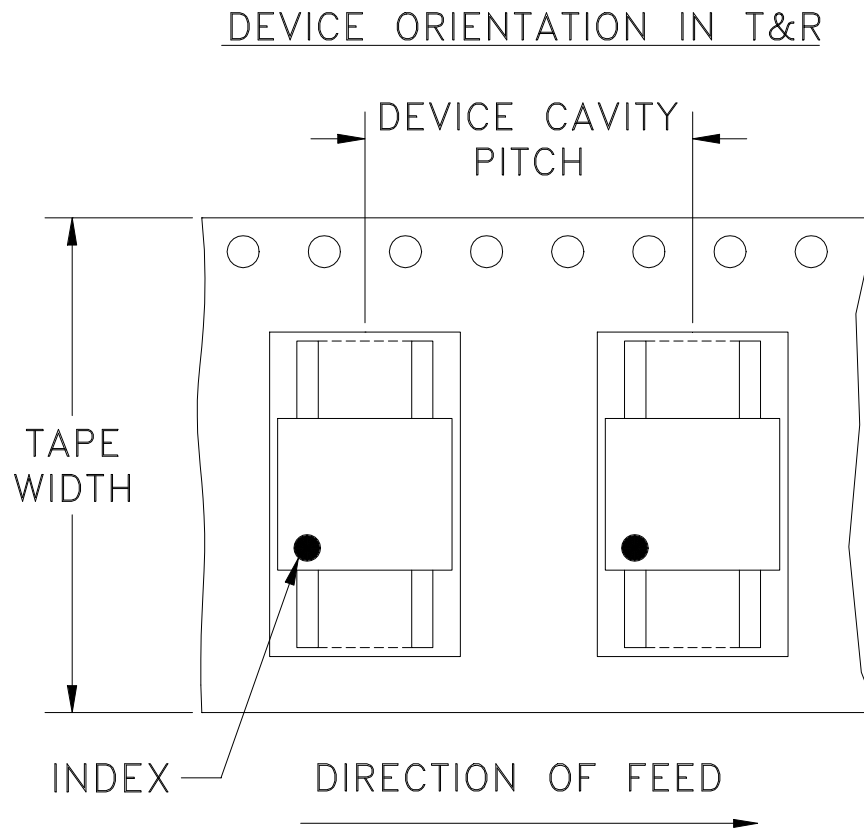
# Tape & Reel Packaging TR-F1



Tape Width, mm	Device Cavity Pitch, mm	Reel Size, inches	Devices per Reel
24	12	13	900

Mini-Circuits carrier tape materials provide protection from ESD (Electro-Static Discharge) during handling and transportation. Tapes are static dissipative and comply with industry standards EIA-481/EIA-541.

Go to: [www.minicircuits.com/pages/pdfs/tape.pdf](http://www.minicircuits.com/pages/pdfs/tape.pdf)



**Distribution Centers** NORTH AMERICA 800-654-7949 • 417-335-5935 • Fax 417-335-5945 • EUROPE 44-1252-832600 • Fax 44-1252-837010

Mini-Circuits ISO 9001 & ISO 14001 Certified

INTERNET <http://www.minicircuits.com>

P.O. Box 350166, Brooklyn, New York 11235-0003 (718) 934-4500 Fax (718) 332-4661

THIRD ANGLE PROJECTION

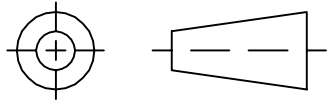

REVISIONS

REV	ECN No.	DESCRIPTION	DATE	DR	AUTH
OR	M102713	NEW RELEASE	01/18/08	MMG	IL

SUGGESTED MOUNTING CONFIGURATION FOR QQQ569 CASE STYLE, "gn" PIN CONNECTION.

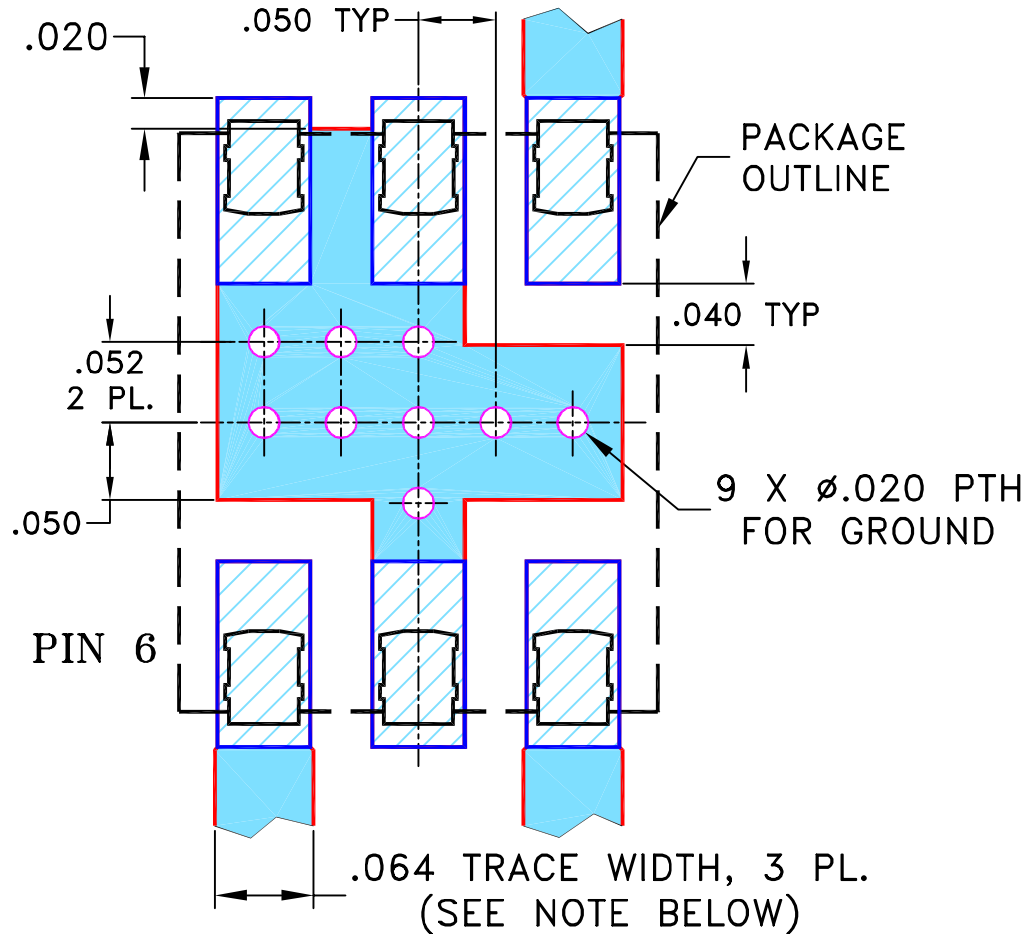

- NOTES: 1. TRACE WIDTH IS SHOWN FOR ROGERS R04350B WITH DIELECTRIC THICKNESS .030" ± .002"; COPPER: 1/2 OZ. EACH SIDE.  
 FOR OTHER MATERIALS TRACE WIDTH MAY NEED TO BE MODIFIED.  
 2. BOTTOM SIDE OF THE PCB IS CONTINUOUS GROUND PLANE.

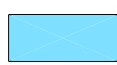

DENOTES PCB COPPER LAYOUT WITH SMOBC (SOLDER MASK OVER BARE COPPER)



DENOTES COPPER LAND PATTERN FREE OF SOLDER MASK

UNLESS OTHERWISE SPECIFIED

INITIALS

DATE

DIMENSIONS ARE IN INCHES

DRAWN

MMG

01/18/08

TOLERANCES ON:

CHECKED

AV

01/18/08

2 PL DECIMALS ±

APPROVED

IL

01/18/08

3 PL DECIMALS ± .005

ANGLES ±

FRACTIONS ±

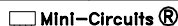

THIS DOCUMENT AND ITS CONTENTS ARE THE PROPERTY OF MINI-CIRCUITS. EXCEPT FOR USE EXPRESSLY GRANTED, IN WRITING, TO ITS VENDORS, VENDEE AND THE UNITED STATES GOVERNMENT, MINI-CIRCUITS RESERVES ALL PROPRIETARY DESIGN, USE, MANUFACTURING AND REPRODUCTION RIGHTS THERETO. THESE CONTENTS SHALL NOT BE USED, DUPLICATED OR DISCLOSED TO ANY OUTSIDE PARTY, IN WHOLE OR IN PART, WITHOUT WRITTEN PERMISSION OF MINI-CIRCUITS.

ASHEETA1.DWG REV:A DATE:01/12/95



Mini-Circuits®

13 Neptune Avenue  
Brooklyn NY 11235

PL, gn, QQQ569, LRPS-J, TB-100

SIZE A	CODE IDENT 15542	DRAWING NO: 98-PL-237	REV: OR
-----------	---------------------	--------------------------	------------

FILE: 98PL237	SCALE: 8:1	SHEET: 1 OF 1
------------------	---------------	------------------





All Mini-Circuits products are manufactured under exacting quality assurance and control standards, and are capable of meeting published specifications after being subjected to any or all of the following physical and environmental test.

Specification	Test/Inspection Condition	Reference/Spec
Operating Temperature	-40° to 85°C Ambient Environment	Individual Model Data Sheet
Storage Temperature	-55° to 100° C Ambient Environment	Individual Model Data Sheet
Humidity	90 to 95% RH, 240 hours, 50°C	MIL-STD-202, Method 103, Condition A, Except 50°C and end-point electrical test done within 12 hours
Thermal Shock	-55° to 100°C, 100 cycles	MIL-STD-202, Method 107, Condition A-3, except +100°C
Solder Reflow Heat	Sn-Pb Eutetic Process: 225°C peak Pb-Free Process 245° - 250°C peak	J-STD-020, Table 4-1, 4-2 and 5-2, Figure 5-1
Solderability	10X Magnification	J-STD-002, 95% Coverage
Vibration (High Frequency)	20g peak, 10-2000 Hz, 12 times in each of three perpendicular directions (total 36)	MIL-STD-202, Method 204, Condition D
Mechanical Shock	50g, 11 ms, 1/2-sine, 18 shocks: 3 each direction, each of 3 axes	MIL-STD-202, Method 213, Condition A
Marking Resistance to Solvents	Isopropyl alcohol + mineral spirits at 25°C; terpene defluxer at 25°C; distilled water + proylene glycol monomethyl ether + monoethanolamine at 63°C to 70°C	MIL-STD-202, Method 215