



CERAMIC BALUN

RF Transformer

TCW1-422+

50Ω 3100 to 4200 MHz 1:1 Ratio

THE BIG DEAL

- Tiny size, 0603
- Low cost
- DC feeding capability
- Rugged LTCC construction



Generic photo used for illustration purposes only

CASE STYLE: JC0603C

+RoHS Compliant

The +Suffix identifies RoHS Compliance.
See our website for methodologies and qualifications

APPLICATIONS

- 5G application
- Wireless Communication

PRODUCT OVERVIEW

Mini-Circuits' TCW1-422+ is a tiny ceramic RF balun transformer with an impedance ratio of 1:1, covering a variety of wireless communications applications from 3100 to 4200 MHz. This model provides low insertion loss, low phase unbalance (relative to 180°), low amplitude unbalance, and RF input power handling up to 2W. It provides DC isolation from input to output allowing it to be used for DC biasing of external circuits at the output. Fabricated using LTCC technology, the unit comes housed in a tiny, rugged ceramic package (0.06 x 0.03 x 0.02") suitable for harsh operating environments.

KEY FEATURES

Feature	Advantages
2W power handling	Supports a wide range of power requirements
DC Isolated from input to output	Can be used to DC bias external circuits at the output....
Tiny size, 0603	Accommodates tight space requirements for dense PCB layouts
LTCC construction	LTCC process enables tiny size and low cost, suitable for high-volume production. Rugged ceramic package provides excellent reliability in harsh operating environments.

REV. OR
ECO-010936
TCW1-422+
SL/CP/AM
221003





CERAMIC BALUN

RF Transformer

TCW1-422+

50Ω 3100 to 4200 MHz 1:1 Ratio

ELECTRICAL SPECIFICATIONS AT 25°C

Parameter	Frequency (MHz)	Min.	Typ.	Max.	Units
Impedance Ratio		50:50			
Frequency Range		3100		4200	MHz
Insertion Loss	3100-4200		1.1	1.5	dB
Amplitude Unbalance	3100-4200		1	1.5	dB
Phase Unbalance	3100-4200		7	13	Degree
Return Loss Unbalanced Port	3100-4200	9.5			dB

MAXIMUM RATINGS

Parameter	Ratings
Operating Temperature	-55°C to 125°C
Storage Temperature	-55°C to 125°C
RF Power Input	2W*

*Room temperature; Linear derate to 0.5W at 125°C. Permanent damage may occur if any of these limits are exceeded.

CONFIGURATION R

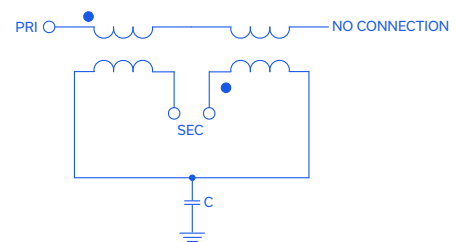



CERAMIC BALUN

RF Transformer

TCW1-422+



50Ω 3100 to 4200 MHz 1:1 Ratio

PAD CONNECTIONS

UNBALANCED PORT	1
BALANCED PORT	3,4
GROUND	5
NOT CONNECT	6
GND or DC feed	2

OUTLINE DRAWING

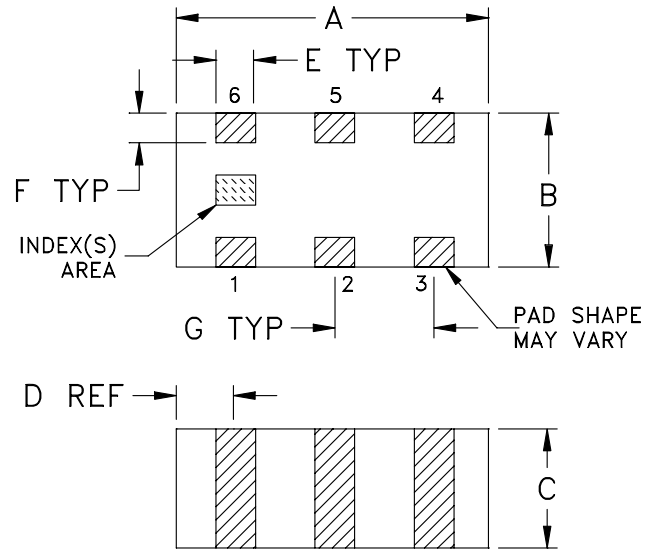

DEMO BOARD MCL P/N: TB-TCW1-422+ SUGGESTED PCB LAYOUT (PL-574)

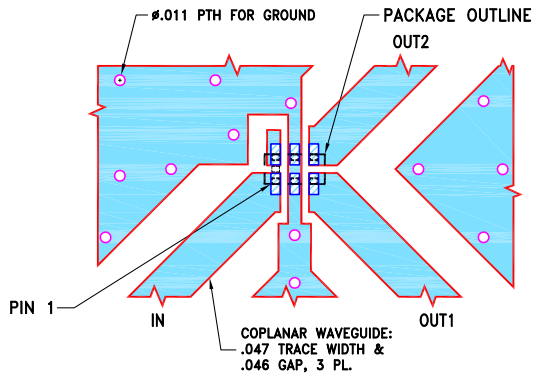

NOTES:

- TRACE WIDTH & GAP PARAMETERS ARE SHOWN FOR ROGERS RO4350B WITH DIELECTRIC THICKNESS $.020 \pm .0015$. COPPER: 1/2 OZ. EACH SIDE. FOR OTHER MATERIALS TRACE WIDTH & GAP MAY NEED TO BE MODIFIED.
- BOTTOM SIDE OF THE PCB IS CONTINUOUS GROUND PLANE.

- DENOTES PCB COPPER LAYOUT WITH SMOBC (SOLDER MASK OVER BARE COPPER).
- DENOTES COPPER LAND PATTERN FREE OF SOLDER MASK.

OUTLINE DIMENSIONS (Inches/mm)

A	B	C	D	E	F	G	wt
.063	.031	.024	.012	.008	.006	.020	grams
1.60	0.79	0.61	0.30	0.20	0.15	0.51	0.005

TAPE & REEL INFORMATION: F114





TYPICAL PERFORMANCE DATA

Frequency (MHz)	Insertion Loss (dB)	Return Loss (dB)	Amplitude Unbalance (dB)	Phase Unbalance (deg)
3100	0.78	15.06	0.40	5.45
3200	0.74	16.39	0.43	4.72
3300	0.72	17.71	0.43	3.94
3400	0.70	18.74	0.40	3.18
3500	0.70	18.79	0.36	2.33
3600	0.72	18.07	0.29	1.48
3700	0.76	16.72	0.20	0.59
3800	0.80	15.39	0.07	0.32
4000	0.91	13.17	0.22	2.24
4200	1.03	11.78	0.60	4.25

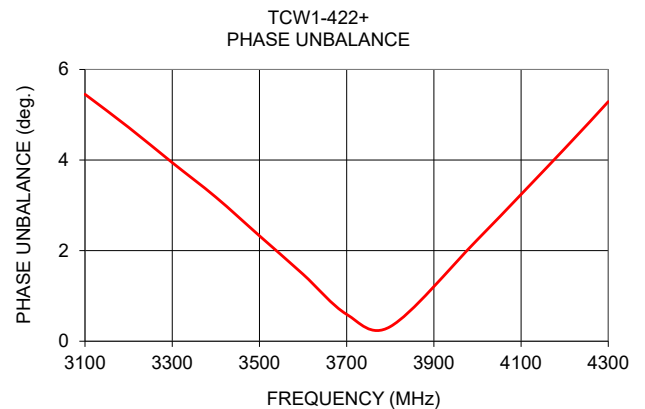
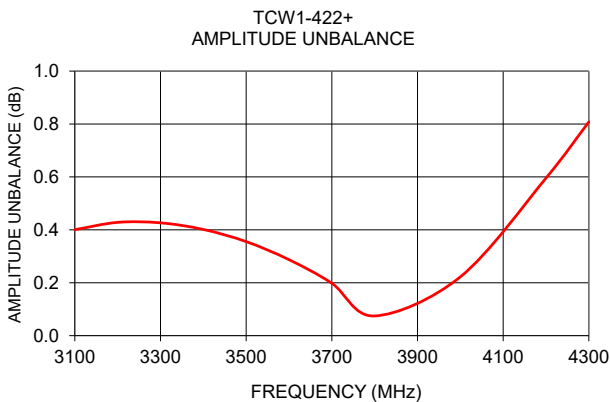
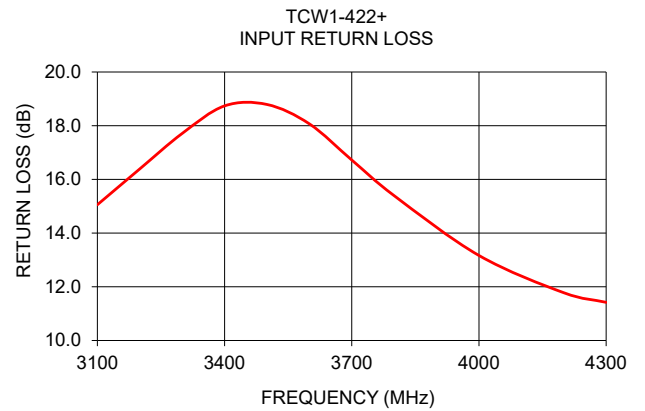
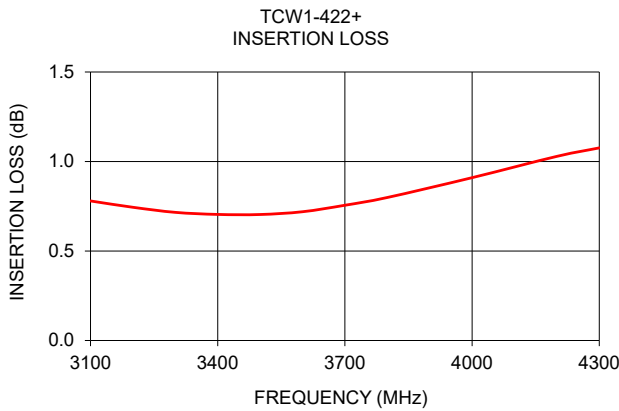

- NOTES**
- A. Performance and quality attributes and conditions not expressly stated in this specification document are intended to be excluded and do not form a part of this specification document.
 - B. Electrical specifications and performance data contained in this specification document are based on Mini-Circuit's applicable established test performance criteria and measurement instructions.
 - C. The parts covered by this specification document are subject to Mini-Circuits standard limited warranty and terms and conditions (collectively, "Standard Terms"); Purchasers of this part are entitled to the rights and benefits contained therein. For a full statement of the standard. Terms and the exclusive rights and remedies thereunder, please visit Mini-Circuits' website at www.minicircuits.com/terms/viewterm.html

Typical Performance Data

FREQUENCY (MHz)	AVERAGE INSERTION LOSS (dB)	INPUT RETURN LOSS (dB)	AMPLITUDE UNBALANCE (dB)	PHASE UNBALANCE (deg.)
3000	0.83	13.94	0.37	6.17
3020	0.82	14.17	0.37	6.02
3040	0.81	14.39	0.38	5.89
3060	0.80	14.61	0.39	5.74
3080	0.79	14.84	0.39	5.60
3100	0.78	15.06	0.40	5.45
3120	0.77	15.30	0.41	5.29
3140	0.77	15.55	0.42	5.17
3160	0.76	15.82	0.42	5.02
3180	0.75	16.10	0.42	4.86
3200	0.74	16.39	0.43	4.72
3220	0.74	16.68	0.43	4.56
3240	0.73	16.96	0.43	4.41
3260	0.72	17.22	0.43	4.26
3280	0.72	17.48	0.43	4.11
3300	0.72	17.71	0.43	3.94
3320	0.71	17.93	0.43	3.78
3340	0.71	18.15	0.42	3.64
3360	0.71	18.36	0.42	3.48
3380	0.70	18.56	0.41	3.34
3400	0.70	18.74	0.40	3.18
3420	0.70	18.85	0.39	3.00
3440	0.70	18.90	0.38	2.85
3460	0.70	18.90	0.37	2.67
3480	0.71	18.86	0.37	2.50
3500	0.70	18.79	0.36	2.33
3520	0.71	18.72	0.35	2.16
3540	0.71	18.60	0.33	2.02
3560	0.71	18.46	0.32	1.83
3580	0.72	18.29	0.30	1.67
3600	0.72	18.07	0.29	1.48
3620	0.73	17.83	0.27	1.31
3640	0.73	17.57	0.25	1.14
3660	0.74	17.28	0.23	0.97
3680	0.75	17.00	0.22	0.76
3700	0.76	16.72	0.20	0.59
3720	0.76	16.46	0.17	0.40
3740	0.77	16.17	0.15	0.23
3760	0.78	15.94	0.13	0.05
3780	0.79	15.67	0.10	0.13
3800	0.80	15.39	0.07	0.32
3820	0.81	15.12	0.04	0.51
3840	0.82	14.86	0.02	0.70
3860	0.83	14.61	0.01	0.91
3880	0.84	14.37	0.03	1.08
3900	0.85	14.16	0.06	1.28
3920	0.86	13.95	0.09	1.47
3940	0.88	13.76	0.12	1.65
3960	0.89	13.57	0.15	1.84
3980	0.90	13.36	0.19	2.05
4000	0.91	13.17	0.22	2.24
4020	0.92	12.98	0.26	2.46
4040	0.94	12.82	0.29	2.66
4060	0.95	12.67	0.33	2.85
4080	0.96	12.52	0.36	3.05
4100	0.97	12.39	0.40	3.26
4120	0.98	12.26	0.43	3.46
4140	0.99	12.13	0.47	3.65
4160	1.01	12.01	0.51	3.86
4180	1.02	11.89	0.55	4.06
4200	1.03	11.78	0.60	4.25
4220	1.04	11.69	0.64	4.47
4240	1.05	11.60	0.68	4.69
4260	1.06	11.53	0.72	4.88
4280	1.07	11.48	0.76	5.08
4300	1.08	11.42	0.81	5.29

Typical Performance Data

Average Insertion Loss

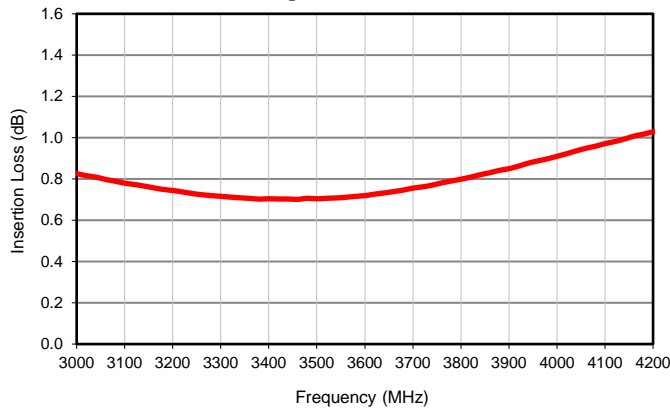

Input Return Loss

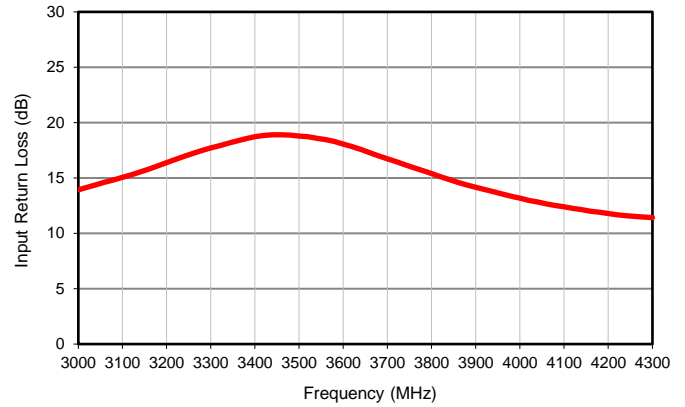

Amplitude Unbalance

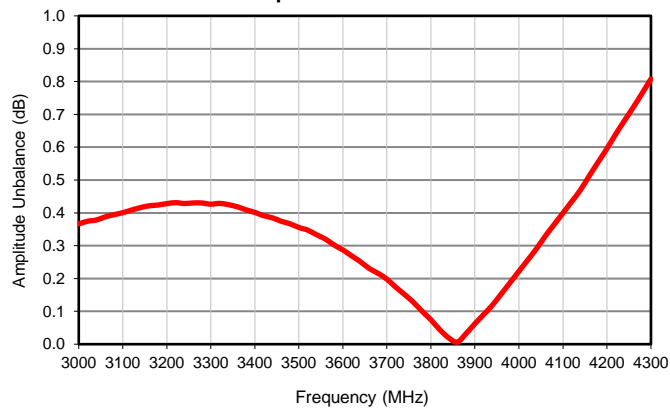

Phase Unbalance

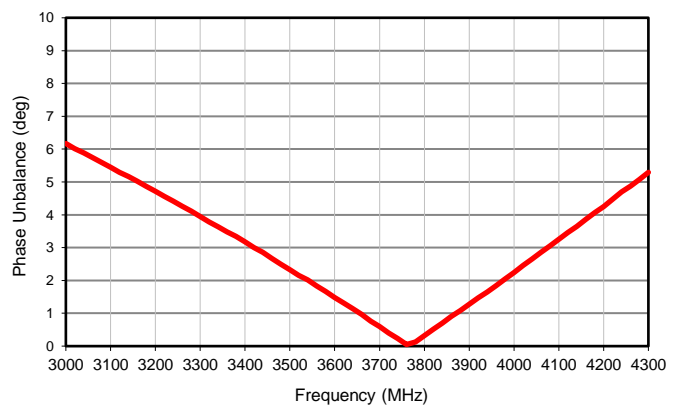

Outline Dimensions

JC0603C

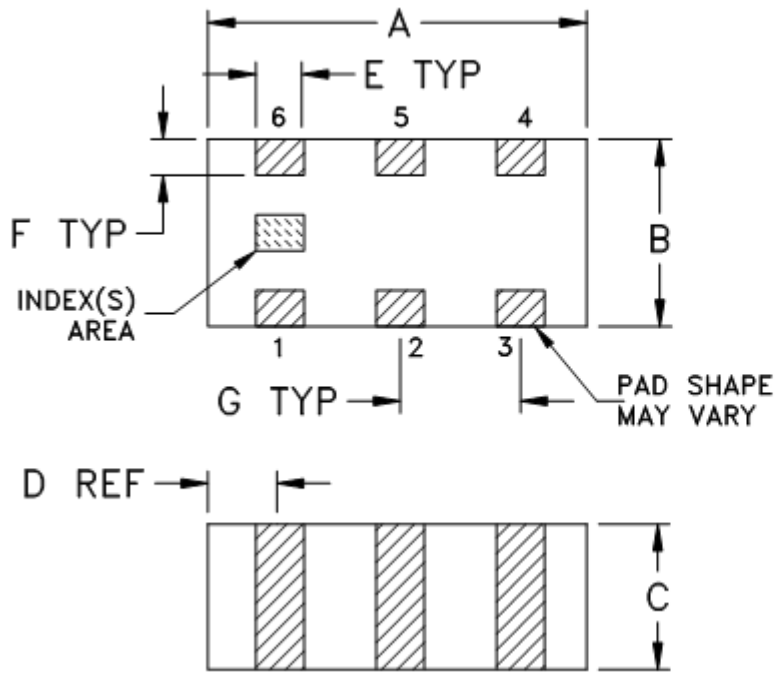

PCB Land Pattern

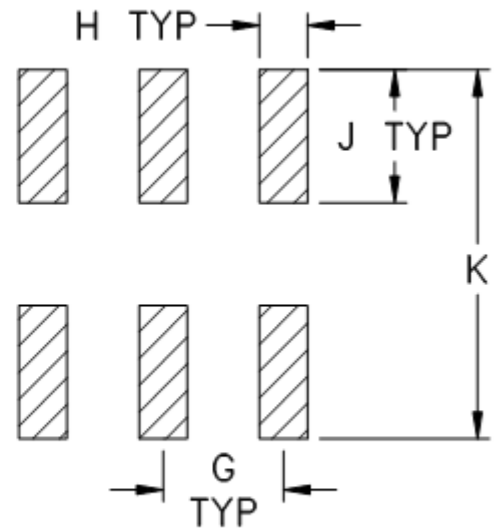

Suggested Layout,
Tolerance to be within $\pm .002$

CASE #	A	B	C	D	E	F	G	H	J	K	WT. GRAM
JC0603C	.063 (1.60)	.031 (0.80)	.024 (0.60)	.012 (0.30)	.008 (0.20)	.006 (0.15)	.020 (0.50)	.010 (0.25)	.022 (0.55)	0.053 (1.35)	.005

Dimensions are in inches (mm). Tolerances: 2 Pl. $\pm .01$; 3 Pl. $\pm .005$

Notes:

- Open style, ceramic base.
- Termination finish:
For RoHS Case Styles: Tin plate over Nickel plate. All models, (+) suffix.



P.O. Box 350166, Brooklyn, New York 11235-0003 (718) 934-4500 Fax (718) 332-4661 For detailed performance specs & shopping online see Mini-Circuits web site



The Design Engineers Search Engine Provides ACTUAL Data Instantly From MINI-CIRCUITS At: www.minicircuits.com

RF/IF MICROWAVE COMPONENTS

Tape & Reel Packaging TR-F114

DEVICE ORIENTATION IN T&R

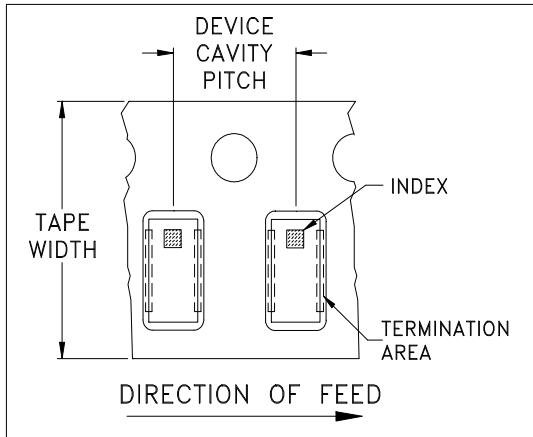

ILLUSTRATION 1

Applicable Case Styles	
GE0805C	JC0603C
GE0805C-1	JC0603C-4
GE0805C-1AP	JC0603C-6
GE0805C-7	
GE0805C-9	
GE0805C-10	
GE0805C-11	
GE0805C-12	

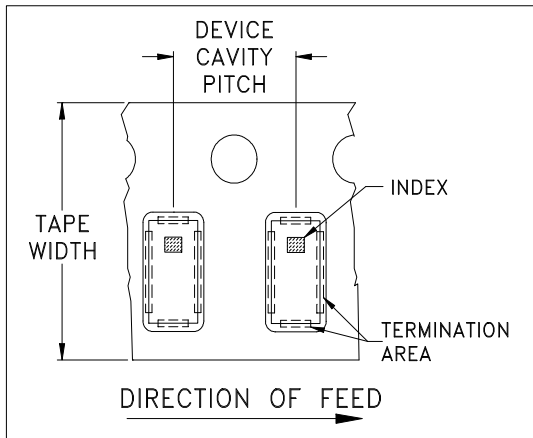

ILLUSTRATION 2

Applicable Case Styles	
GE0805C-2	JC0603C-1
GE0805C-3	JC0603C-2
GE0805C-4	JC0603C-3
GE0805C-5	JC0603C-5
GE0805C-6	JC0603C-7
GE0805C-8	JV1210C-1
GE0805C-15	

Tape Width, mm	Device Cavity Pitch, mm	Reel Size, inches	Devices per Reel	
8	4	7	Small quantity standards (see note)	20
				50
				100
				200
				500
				1000
			Standard	4000

Note: Please Consult individual model data sheet to determine device per reel availability.

Mini-Circuits carrier tape materials provide protection from ESD (Electro-Static Discharge) during handling and transportation. Tapes are static dissipative and comply with industry standards EIA-481/EIA-541.

Go to: www.minicircuits.com/pages/pdfs/tape.pdf



INTERNET <http://www.minicircuits.com>

P.O. Box 350166, Brooklyn, New York 11235-0003 (718) 934-4500 Fax (718) 332-4661

Distribution Centers NORTH AMERICA 800-654-7949 • 417-335-5935 • Fax 417-335-5945 • EUROPE 44-1252-832600 • Fax 44-1252-837010

Mini-Circuits ISO 9001 & ISO 14001 Certified

THIRD ANGLE PROJECTION

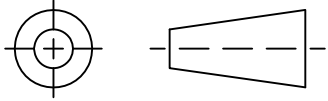

REVISIONS

REV	ECN No.	DESCRIPTION	DATE	DR	AUTH
OR	M166452	NEW RELEASE	02/22/18	ITG	BK

SUGGESTED MOUNTING CONFIGURATION
FOR JC0603C CASE STYLE, "06TR01" PIN CODE

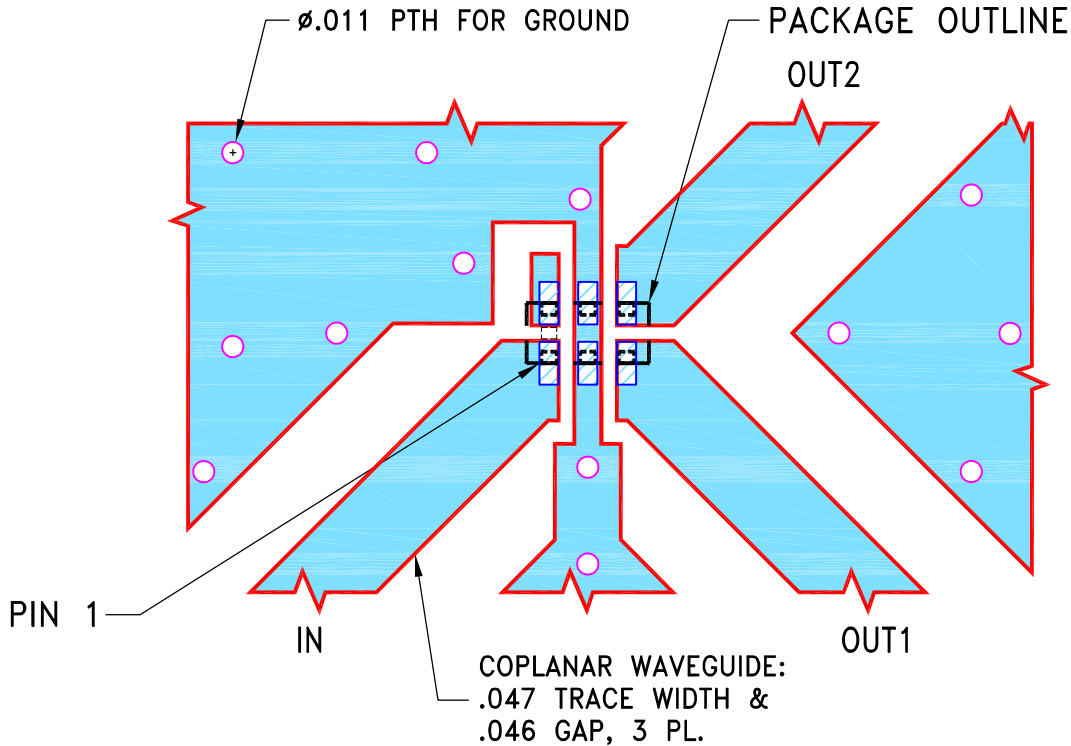

NOTES:

1. TRACE WIDTH & GAP PARAMETERS ARE SHOWN FOR ROGERS R04350B WITH DIELECTRIC THICKNESS $.020 \pm .0015$. COPPER: 1/2 OZ. EACH SIDE. FOR OTHER MATERIALS TRACE WIDTH & GAP MAY NEED TO BE MODIFIED.
2. BOTTOM SIDE OF THE PCB IS CONTINUOUS GROUND PLANE.



DENOTES PCB COPPER LAYOUT WITH SMOBC (SOLDER MASK OVER BARE COPPER).

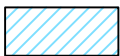

DENOTES COPPER LAND PATTERN FREE OF SOLDER MASK.

UNLESS OTHERWISE SPECIFIED	INITIALS		DATE
DIMENSIONS ARE IN INCHES TOLERANCES ON: 2 PL DECIMALS ± 3 PL DECIMALS ± .005 ANGLES ± FRACTIONS ±	DRAWN	ITG	02/20/18
	CHECKED	GF	02/21/18
	APPROVED	BK	02/22/18



Mini-Circuits®

13 Neptune Avenue
Brooklyn NY 11235

PL, 06TR01, JC0603C, TB-912+

Mini-Circuits®
 THIS DOCUMENT AND ITS CONTENTS ARE THE PROPERTY OF MINI-CIRCUITS. EXCEPT FOR USE EXPRESSLY GRANTED, IN WRITING, TO ITS VENDORS, VENDEE AND THE UNITED STATES GOVERNMENT, MINI-CIRCUITS RESERVES ALL PROPRIETARY DESIGN, USE, MANUFACTURING AND REPRODUCTION RIGHTS THERETO. THESE CONTENTS SHALL NOT BE USED, DUPLICATED OR DISCLOSED TO ANY OUTSIDE PARTY, IN WHOLE OR IN PART, WITHOUT WRITTEN PERMISSION OF MINI-CIRCUITS.

SIZE	CODE IDENT	DRAWING NO:	REV:
A	15542	98-PL-574	OR
FILE:	98PL574	SCALE: 10:1	SHEET: 1 OF 1

Evaluation Board and Circuit

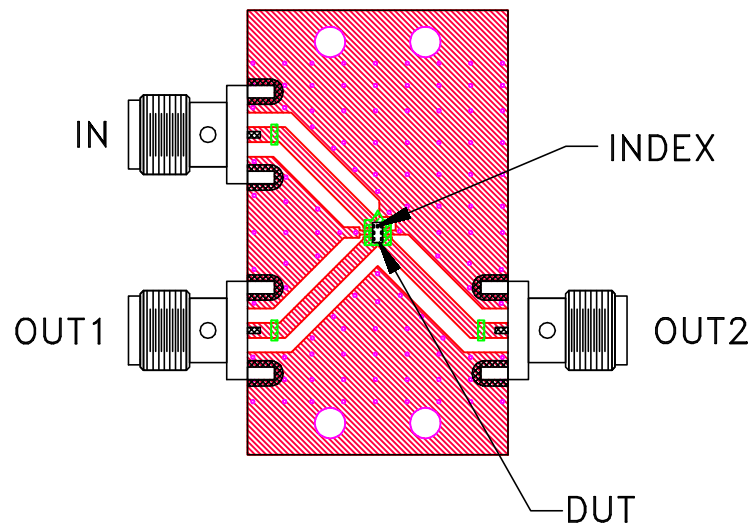

TB-912+

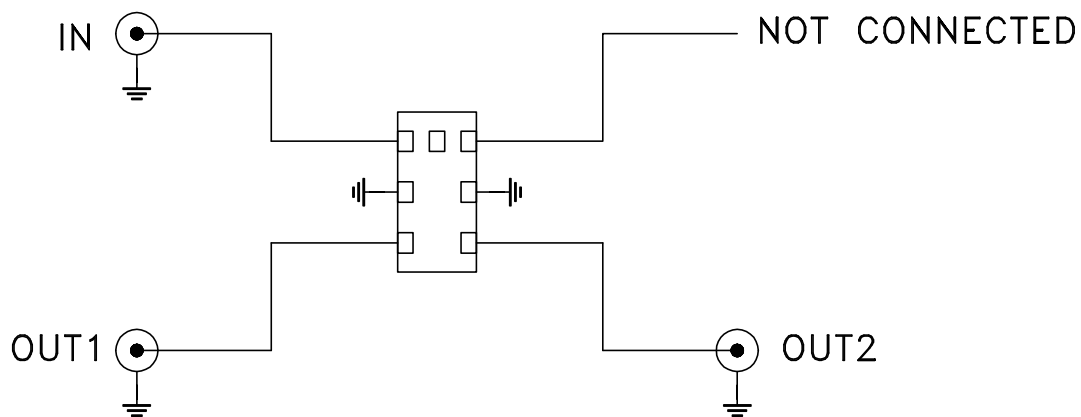

Schematic Diagram

Notes:

1. 50 Ohm SMA Female connectors.
2. PCB Material: R04350 or equivalent,
Dielectric Constant=3.5,
Thickness=.020 inch.

 **Mini-Circuits®**



All Mini-Circuits products are manufactured under exacting quality assurance and control standards, and are capable of meeting published specifications after being subjected to any or all of the following physical and environmental test.

Specification	Test/Inspection Condition	Reference/Spec
Operating Temperature	-55° to 125° C Ambient Environment	Individual Model Data Sheet
Storage Temperature	-55° to 125° C Ambient Environment	Individual Model Data Sheet
Humidity	90 to 95% RH, 240 hours, 50°C	MIL-STD-202, Method 103, Condition A, Except 50°C and end-point electrical test done within 12 hours
Solder Reflow Heat	Sn-Pb Eutectic Process: 225°C peak Pb-Free Process: 250°C peak	J-STD-020C, Table 4-1, 4-2 and 5-2; Figure 5-1
Solderability	10X Magnification	J-STD-002, Para 4.2.5, Test S, 95% Coverage
Vibration (High Frequency)	20g peak, 10-2000 Hz, 12 times in each of three perpendicular directions (total 36)	MIL-STD-202, Method 204, Condition D
Mechanical Shock	50g, 11 ms, 1/2-sine, 18 shocks: 3 each direction, each of 3 axes	MIL-STD-202, Method 213, Condition A