



CERAMIC BALUN

RF Transformer

TCW1-3901+

50Ω 3300 to 3900 MHz 1:1 Ratio

FEATURES

- Wideband, 3300 to 3900 MHz
- Tiny size 0603 (1.6x0.8mm)
- LTCC construction
- Low cost

APPLICATIONS

- Wi-Fi
- ISM
- LTE
- A/D conversion
- Aviation/aeronautical



Generic photo used for illustration purposes only

CASE STYLE: JC0603C

+RoHS Compliant

The +Suffix identifies RoHS Compliance. See our website for methodologies and qualifications

PRODUCT OVERVIEW

Mini-Circuits' TCW1-3901+ is a tiny ceramic RF balun transformer with an impedance ratio of 1:1, covering a variety of wireless communications applications from 3300 to 3900 MHz. This model provides low insertion loss, low phase unbalance (relative to 180°), low amplitude unbalance, and RF input power handling up to 1W. Fabricated using LTCC technology, the unit comes housed in a tiny, rugged ceramic package (0.06 x 0.03 x 0.02") suitable for harsh operating environments.

KEY FEATURES

Feature	Advantages
Low insertion loss, 1.0 dB	Enables excellent signal power transmission from input to output.
Low unbalance, 0.4 dB, 4°	Low unbalance can improve a system's electromagnetic compatibility by rejecting unwanted common-mode noise.
1W power handling	Supports a wide range of power requirements
Tiny size, 0603	Accommodates tight space requirements for dense PCB layouts.
LTCC construction	LTCC process enables tiny size and low cost, suitable for high-volume production. Rugged ceramic package provides excellent reliability in harsh operating environments.

REV. A
ECO-010340
TCW1-3901+
AVB/TD/CP/AM
221003





CERAMIC BALUN

RF Transformer

TCW1-3901+



50Ω 3300 to 3900 MHz 1:1 Ratio

ELECTRICAL SPECIFICATIONS AT 25°C

Parameter	Frequency (MHz)	Min.	Typ.	Max.	Units
Impedance Ratio			1		
Frequency Range		3300		3900	MHz
(Avg) Insertion Loss	3300 - 3900	—	0.9	1.5	dB
Amplitude Unbalance	3300 - 3900	—	0.4	0.9	dB
Phase Unbalance ¹	3300 - 3900	—	4	11	Degree
Input VSWR	3300 - 3900	—	1.4	—	(:1)

1. Relative to 180°

Note: Tested on TB-922+ and with pin 2 grounded.

MAXIMUM RATINGS

Parameter	Ratings
Operating Temperature	-40°C to 85°C
Storage Temperature	-55°C to 100°C
RF Power Input ²	1W

2. Passband rating

Permanent damage may occur if any of these limits are exceeded.

CONFIGURATION G

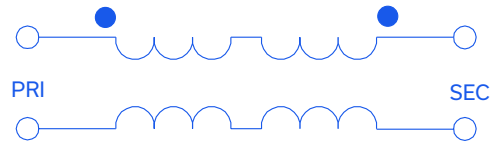



CERAMIC BALUN

RF Transformer

TCW1-3901+



50Ω 3300 to 3900 MHz 1:1 Ratio

PAD CONNECTIONS

PRIMARY DOT	1
PRIMARY	2
SECONDARY DOT	4
SECONDARY	5
NO CONNECTION	3,6

OUTLINE DRAWING

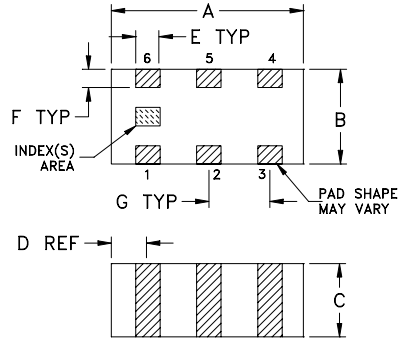

PCB Land Pattern

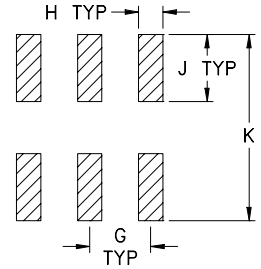

Suggested Layout,
Tolerance to be within ±.002

PRODUCT MARKING: N/A

DEMO BOARD MCL P/N: TB-922+ SUGGESTED PCB LAYOUT (PL-537)

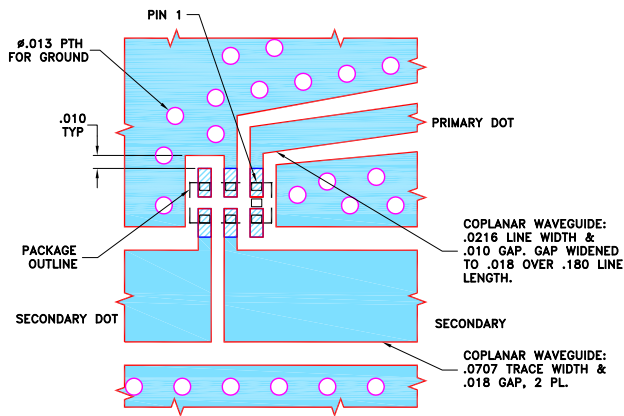

NOTES:

- TRACE WIDTH PARAMETERS ARE SHOWN FOR ROGERS RO4350B WITH DIELECTRIC THICKNESS .010±.001". COPPER: 1/2 OZ. EACH SIDE. FOR OTHER MATERIALS LINE WIDTH AND GAP MAY NEED TO BE MODIFIED.
- BOTTOM SIDE OF THE PCB IS CONTINUOUS GROUND PLANE.

- DENOTES PCB COPPER LAYOUT WITH SMOBC (SOLDER MASK OVER BARE COPPER).
- DENOTES COPPER LAND PATTERN FREE OF SOLDER MASK.

OUTLINE DIMENSIONS (Inches/mm)

A	B	C	D	E	F
.063	.031	.024	.012	.008	.006
1.60	0.79	0.61	0.30	0.20	0.15
G	H	J	K		wt
.020	.010	.022	.053		grams
0.51	0.25	0.56	1.35		0.005

TAPE & REEL INFORMATION: F114





CERAMIC BALUN

RF Transformer

TCW1-3901+



50Ω 3300 to 3900 MHz 1:1 Ratio

TYPICAL PERFORMANCE DATA³

Frequency (MHz)	Insertion Loss (dB)	Input Return Loss (dB)	Amplitude Unbalance (dB)	Phase Unbalance (deg)
3300	0.80	1.42	0.02	6.09
3350	0.81	1.43	0.02	5.85
3400	0.82	1.44	0.08	5.72
3450	0.83	1.44	0.12	5.57
3500	0.84	1.44	0.15	5.28
3600	0.86	1.45	0.24	4.96
3700	0.87	1.44	0.30	4.60
3800	0.88	1.42	0.34	4.69
3850	0.88	1.41	0.33	4.66
3900	0.88	1.39	0.32	4.37

3. Measured with Agilent N5242A network analyzer using impedance conversion and port extension.

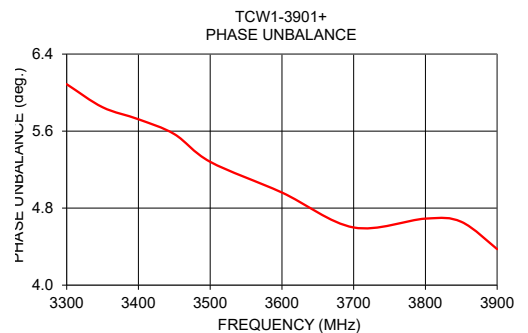
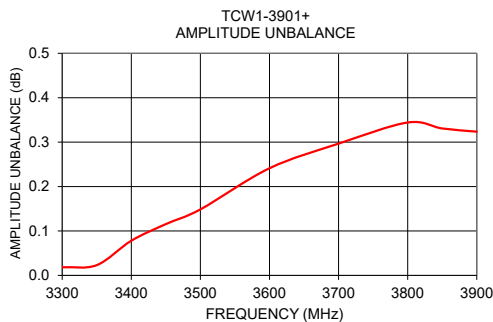
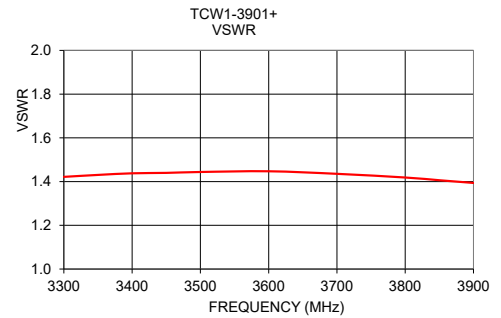
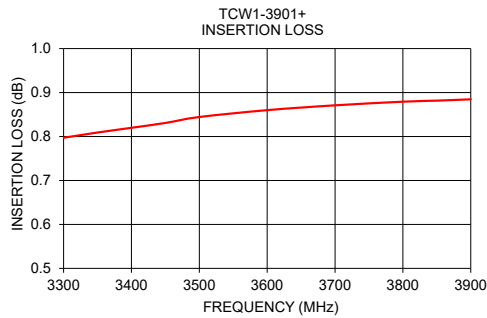

- NOTES**
- A. Performance and quality attributes and conditions not expressly stated in this specification document are intended to be excluded and do not form a part of this specification document.
 - B. Electrical specifications and performance data contained in this specification document are based on Mini-Circuit's applicable established test performance criteria and measurement instructions.
 - C. The parts covered by this specification document are subject to Mini-Circuits standard limited warranty and terms and conditions (collectively, "Standard Terms"); Purchasers of this part are entitled to the rights and benefits contained therein. For a full statement of the standard. Terms and the exclusive rights and remedies thereunder, please visit Mini-Circuits' website at www.minicircuits.com/terms/viewterm.html



RF Transformer

TCW1-3901+

Typical Performance Data

FREQUENCY (MHz)	INSERTION LOSS (dB)	INPUT RETURN LOSS (dB)	AMPLITUDE UNBALANCE (dB)	PHASE UNBALANCE ⁽¹⁾ (Deg)
2500	0.67	19.42	1.46	4.67
2550	0.67	19.16	1.34	4.91
2600	0.67	18.85	1.21	5.15
2650	0.67	18.53	1.10	5.35
2700	0.68	18.21	0.99	5.47
2750	0.68	17.90	0.89	5.57
2800	0.69	17.58	0.78	5.69
2850	0.70	17.27	0.67	5.76
2900	0.70	16.95	0.57	5.85
2950	0.71	16.66	0.48	5.97
3000	0.72	16.37	0.39	6.07
3050	0.73	16.11	0.31	6.12
3100	0.75	15.90	0.23	6.11
3150	0.76	15.67	0.17	6.11
3200	0.77	15.45	0.10	6.20
3250	0.79	15.31	0.05	6.26
3300	0.80	15.18	0.02	6.09
3325	0.80	15.11	0.00	5.96
3350	0.81	15.03	0.02	5.85
3375	0.81	14.96	0.05	5.77
3400	0.82	14.91	0.08	5.72
3425	0.83	14.89	0.10	5.67
3450	0.83	14.88	0.12	5.57
3475	0.84	14.86	0.13	5.44
3500	0.84	14.82	0.15	5.28
3525	0.85	14.77	0.17	5.14
3550	0.85	14.74	0.19	5.04
3575	0.86	14.74	0.22	4.99
3600	0.86	14.76	0.24	4.96
3625	0.86	14.81	0.26	4.91
3650	0.86	14.87	0.27	4.82
3675	0.87	14.92	0.28	4.70
3700	0.87	14.95	0.30	4.60
3725	0.87	15.00	0.31	4.54
3750	0.88	15.05	0.33	4.57
3775	0.88	15.13	0.34	4.62
3800	0.88	15.23	0.34	4.69
3825	0.88	15.34	0.34	4.72
3850	0.88	15.45	0.33	4.66
3875	0.88	15.56	0.33	4.53
3900	0.88	15.68	0.32	4.37
3950	0.89	15.97	0.33	4.13
4000	0.89	16.34	0.33	4.10
4050	0.89	16.76	0.31	4.07
4100	0.89	17.23	0.30	3.92
4150	0.89	17.80	0.29	3.79
4200	0.90	18.42	0.26	3.78
4250	0.90	19.15	0.23	3.68
4300	0.90	20.03	0.20	3.42
4350	0.91	20.93	0.19	3.23
4400	0.91	21.75	0.15	3.18
4450	0.92	22.52	0.12	3.07
4500	0.93	23.18	0.11	2.90
4550	0.94	23.32	0.09	2.89
4600	0.96	22.78	0.06	2.95
4650	0.98	21.85	0.02	2.92
4700	0.99	20.81	0.01	2.76
4750	1.02	19.63	0.03	2.76
4800	1.04	18.30	0.07	2.94
4850	1.08	17.07	0.12	3.00
4900	1.11	16.05	0.15	2.87
4950	1.15	15.09	0.16	2.89
5000	1.20	14.11	0.17	3.18

⁽¹⁾ Relative to 180°



P.O. Box 350166, Brooklyn, New York 11235-0003 (718) 934-4500 • Fax (718) 332-4661 For detailed performance specs & shopping online see Mini-Circuits web site



The Design Engineers Search Engine Provides ACTUAL Data Instantly From MINI-CIRCUITS At: www.minicircuits.com

IF/RF MICROWAVE COMPONENTS

REV. OR
TCW1-3901+
3/20/2018
Page 1 of 1

Typical Performance Data

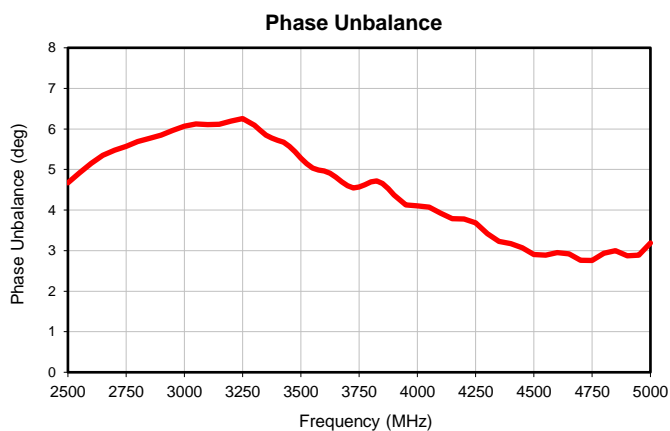
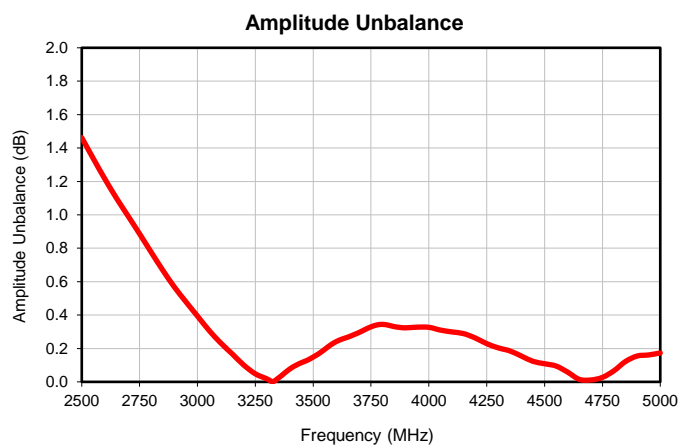
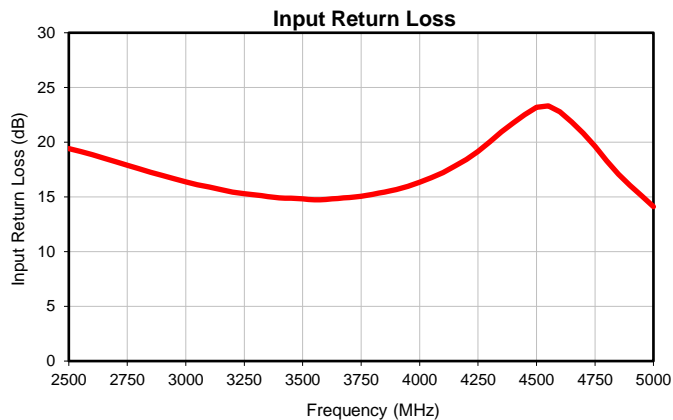
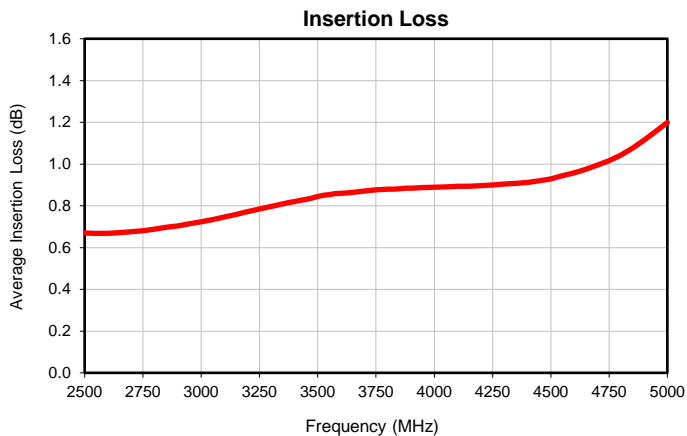

Outline Dimensions

JC0603C

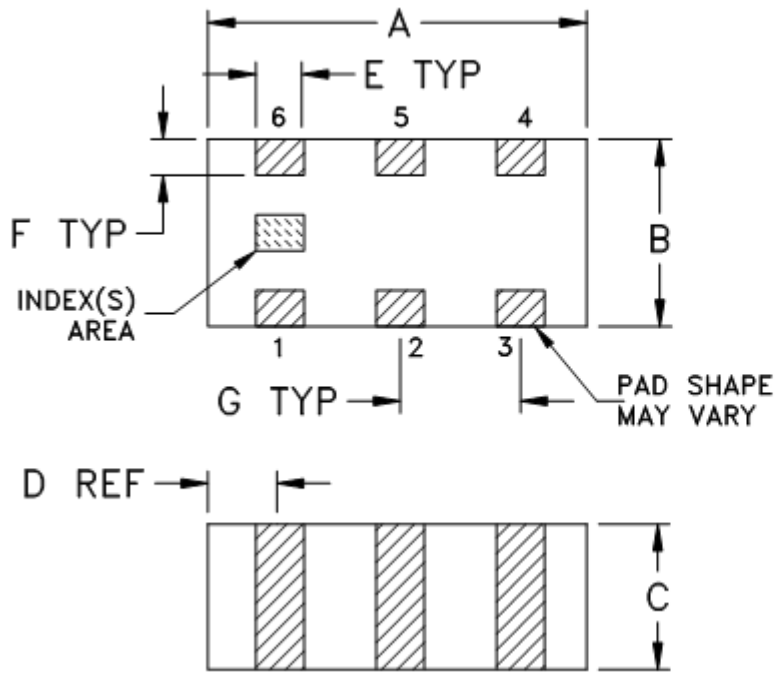

PCB Land Pattern

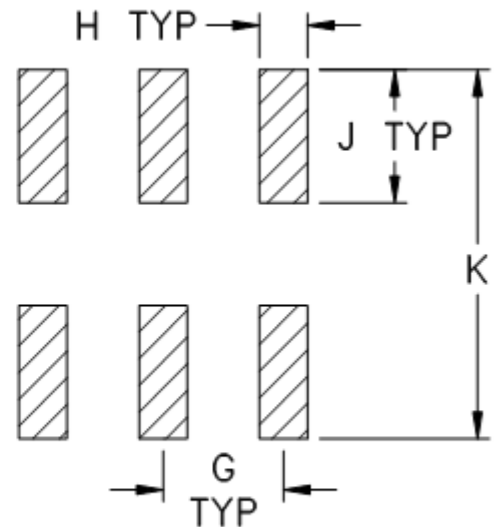

Suggested Layout,
Tolerance to be within $\pm .002$

CASE #	A	B	C	D	E	F	G	H	J	K	WT. GRAM
JC0603C	.063 (1.60)	.031 (0.80)	.024 (0.60)	.012 (0.30)	.008 (0.20)	.006 (0.15)	.020 (0.50)	.010 (0.25)	.022 (0.55)	0.053 (1.35)	.005

Dimensions are in inches (mm). Tolerances: 2 Pl. $\pm .01$; 3 Pl. $\pm .005$

Notes:

1. Open style, ceramic base.
2. Termination finish:
For RoHS Case Styles: Tin plate over Nickel plate. All models, (+) suffix.



P.O. Box 350166, Brooklyn, New York 11235-0003 (718) 934-4500 Fax (718) 332-4661 For detailed performance specs & shopping online see Mini-Circuits web site



The Design Engineers Search Engine Provides ACTUAL Data Instantly From MINI-CIRCUITS At: www.minicircuits.com

RF/IF MICROWAVE COMPONENTS

Tape & Reel Packaging TR-F114

DEVICE ORIENTATION IN T&R

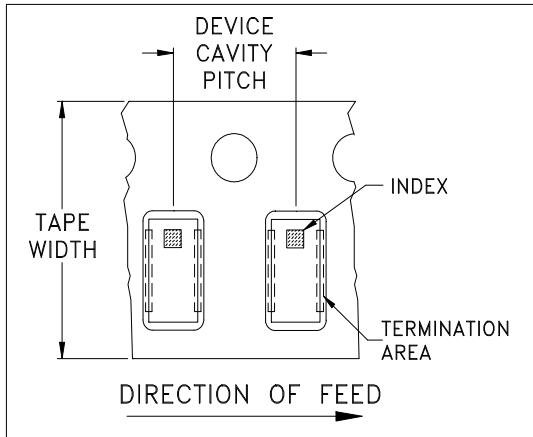

ILLUSTRATION 1

Applicable Case Styles	
GE0805C	JC0603C
GE0805C-1	JC0603C-4
GE0805C-1AP	JC0603C-6
GE0805C-7	
GE0805C-9	
GE0805C-10	
GE0805C-11	
GE0805C-12	

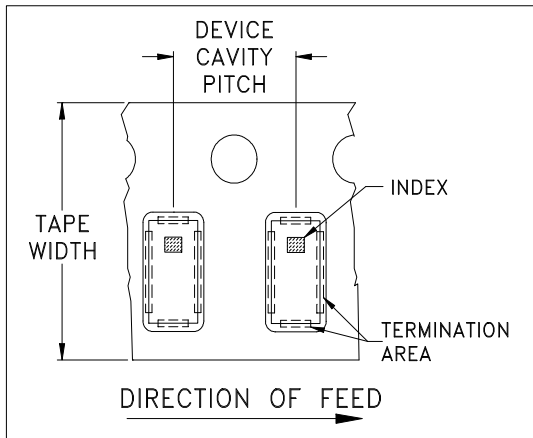

ILLUSTRATION 2

Applicable Case Styles	
GE0805C-2	JC0603C-1
GE0805C-3	JC0603C-2
GE0805C-4	JC0603C-3
GE0805C-5	JC0603C-5
GE0805C-6	JC0603C-7
GE0805C-8	JV1210C-1
GE0805C-15	

Tape Width, mm	Device Cavity Pitch, mm	Reel Size, inches	Devices per Reel	
8	4	7	Small quantity standards (see note)	20
				50
				100
				200
				500
				1000
			Standard	4000

Note: Please Consult individual model data sheet to determine device per reel availability.

Mini-Circuits carrier tape materials provide protection from ESD (Electro-Static Discharge) during handling and transportation. Tapes are static dissipative and comply with industry standards EIA-481/EIA-541.

Go to: www.minicircuits.com/pages/pdfs/tape.pdf



INTERNET <http://www.minicircuits.com>

P.O. Box 350166, Brooklyn, New York 11235-0003 (718) 934-4500 Fax (718) 332-4661

Distribution Centers NORTH AMERICA 800-654-7949 • 417-335-5935 • Fax 417-335-5945 • EUROPE 44-1252-832600 • Fax 44-1252-837010

Mini-Circuits ISO 9001 & ISO 14001 Certified

THIRD ANGLE PROJECTION

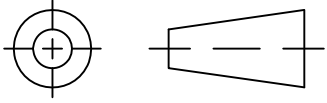

REVISIONS

REV	ECN No.	DESCRIPTION	DATE	DR	AUTH
OR	M165159	NEW RELEASE	12/19/17	ITG	BK

**SUGGESTED MOUNTING CONFIGURATION
FOR JC0603C CASE STYLE, "06TG06" PIN CODE**

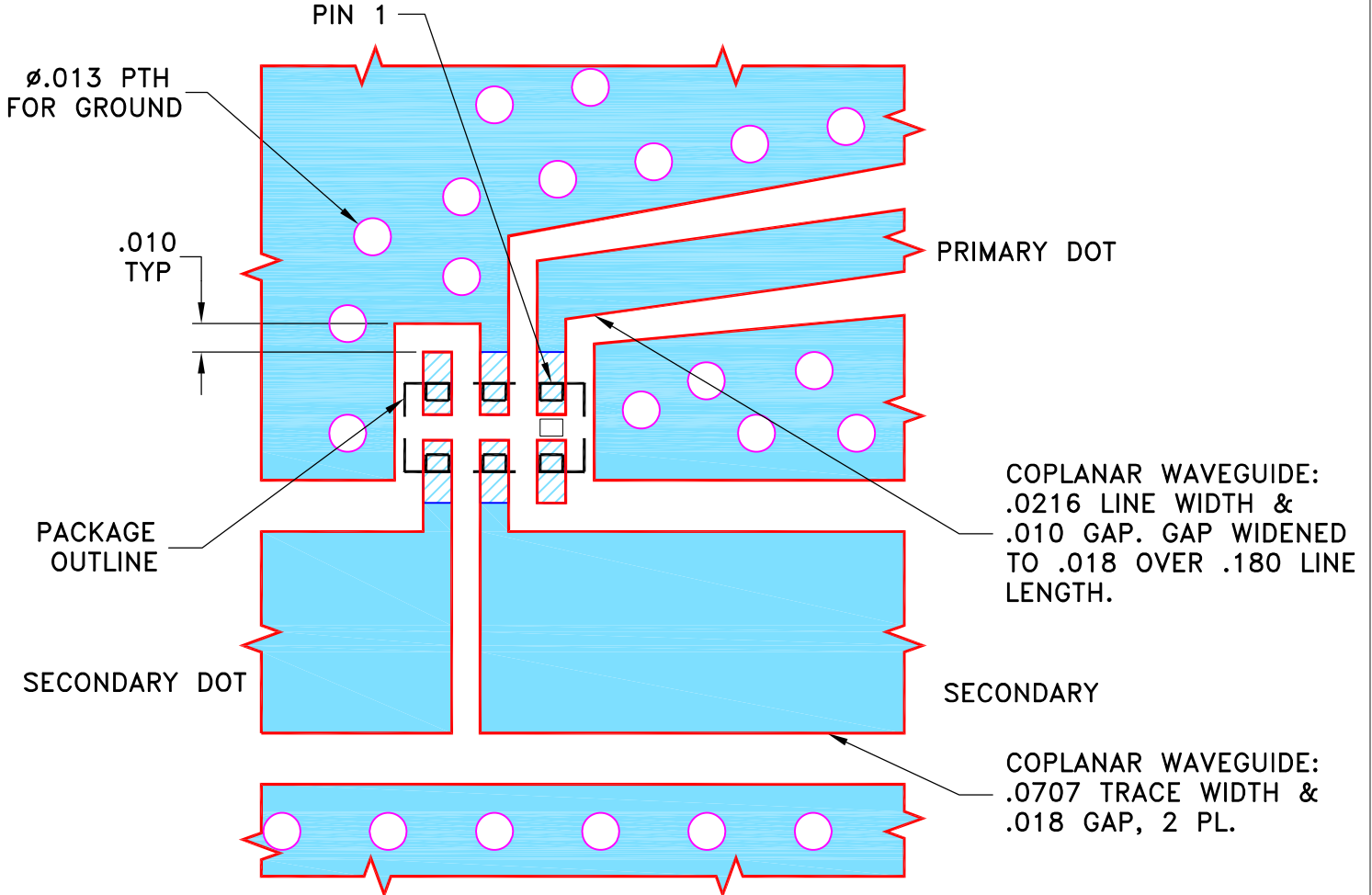

NOTES:

- TRACE WIDTH PARAMETERS ARE SHOWN FOR ROGERS R04350B WITH DIELECTRIC THICKNESS .010"±.001". COPPER: 1/2 OZ. EACH SIDE. FOR OTHER MATERIALS LINE WIDTH AND GAP MAY NEED TO BE MODIFIED.
- BOTTOM SIDE OF THE PCB IS CONTINUOUS GROUND PLANE.



DENOTES PCB COPPER LAYOUT WITH SMOBC (SOLDER MASK OVER BARE COPPER).

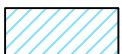

DENOTES COPPER LAND PATTERN FREE OF SOLDER MASK.

UNLESS OTHERWISE SPECIFIED	INITIALS		DATE
DIMENSIONS ARE IN INCHES TOLERANCES ON: 2 PL DECIMALS ± 3 PL DECIMALS ± .005 ANGLES ± FRACTIONS ±	DRAWN	ITG	12/14/17
	CHECKED	GF	12/19/17
	APPROVED	BK	12/19/17



Mini-Circuits®

13 Neptune Avenue
Brooklyn NY 11235

PL, 06TG06, JC0603C, TB-922+

SIZE A	CODE IDENT 15542	DRAWING NO: 98-PL-537	REV: OR
FILE: 98PL537	SCALE: 16:1	SHEET: 1 OF 1	

THIS DOCUMENT AND ITS CONTENTS ARE THE PROPERTY OF MINI-CIRCUITS. EXCEPT FOR USE EXPRESSLY GRANTED, IN WRITING, TO ITS VENDORS, VENDEE AND THE UNITED STATES GOVERNMENT, MINI-CIRCUITS RESERVES ALL PROPRIETARY DESIGN, USE, MANUFACTURING AND REPRODUCTION RIGHTS THERETO. THESE CONTENTS SHALL NOT BE USED, DUPLICATED OR DISCLOSED TO ANY OUTSIDE PARTY, IN WHOLE OR IN PART, WITHOUT WRITTEN PERMISSION OF MINI-CIRCUITS.

Evaluation Board and Circuit

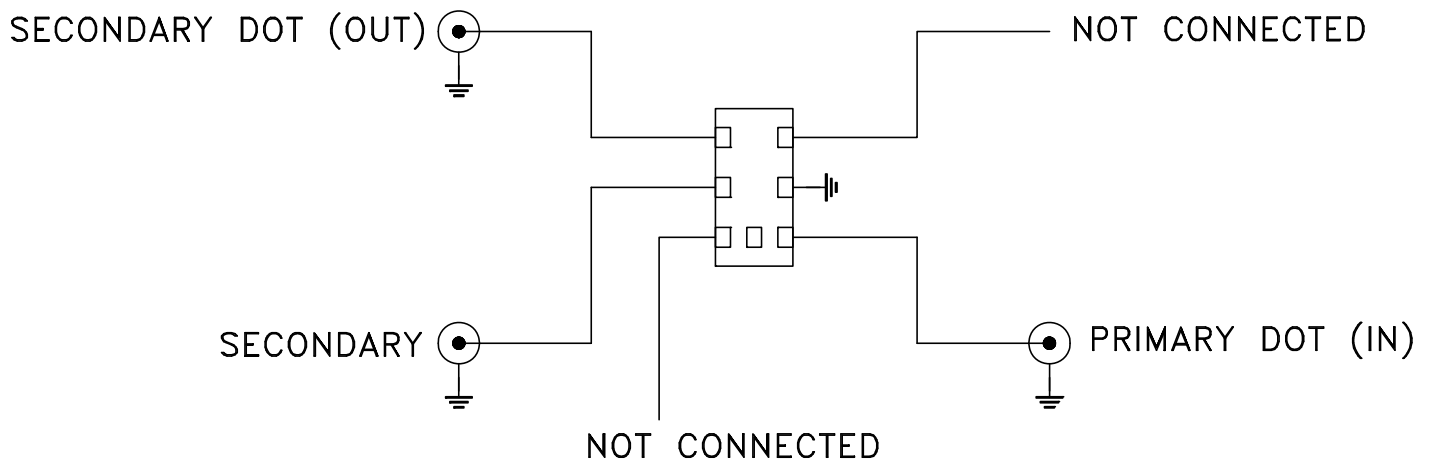
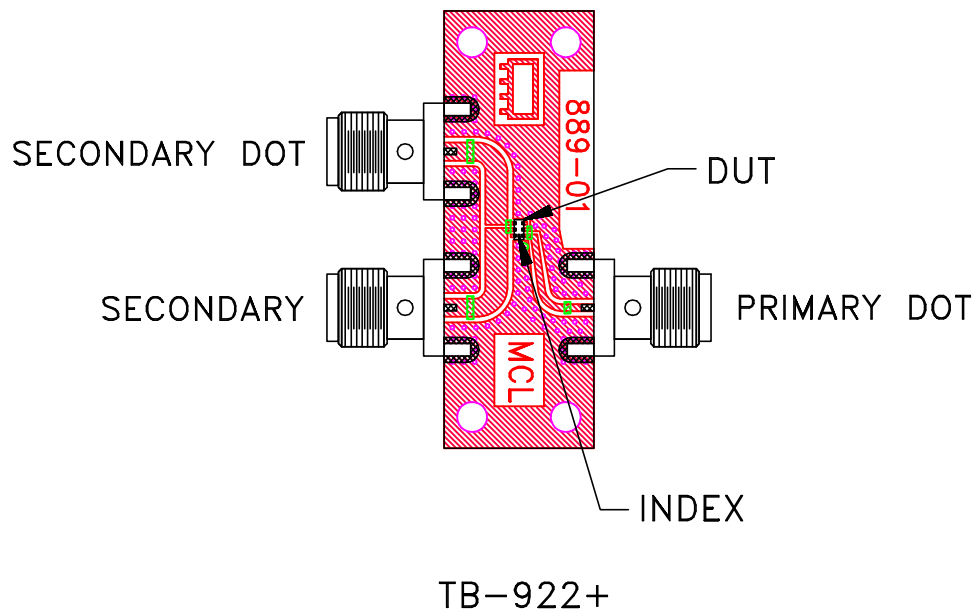

Schematic Diagram

Notes:

1. 50 Ohm SMA Female connectors.
2. PCB Material: R04350 or equivalent, Dielectric Constant=3.5, Thickness=.020 inch.

 **Mini-Circuits®**

All Mini-Circuits products are manufactured under exacting quality assurance and control standards, and are capable of meeting published specifications after being subjected to any or all of the following physical and environmental test.

Specification	Test/Inspection Condition	Reference/Spec
Operating Temperature	-55° to 100°C Ambient Environment	Individual Model Data Sheet
Storage Temperature	-55° to 100° C Ambient Environment	Individual Model Data Sheet
Humidity	90 to 95% RH, 240 hours, 50°C	MIL-STD-202, Method 103, Condition A, Except 50°C and end-point electrical test done within 12 hours
Solder Reflow Heat	Sn-Pb Eutetic Process: 225°C peak Pb-Free Process 245° - 250°C peak	J-STD-020, Table 4-1, 4-2 and 5-2, Figure 5-1
Solderability	10X Magnification	J-STD-002, Para 4.2.5, Test S, 95% Coverage
Vibration (High Frequency)	20g peak, 10-2000 Hz, 12 times in each of three perpendicular directions (total 36)	MIL-STD-202, Method 204, Condition D
Mechanical Shock	50g, 11 ms, 1/2-sine, 18 shocks: 3 each direction, each of 3 axes	MIL-STD-202, Method 213, Condition A