



**SURFACE MOUNT**

# Power Splitter/Combiner **TCP-2-10+**

50Ω 2 Way-0° 5 to 1000 MHz

## FEATURES

- Low insertion, 0.5 dB typ.
- Excellent amplitude unbalance, 0.1 dB typ.
- Very good phase unbalance, 1.0 deg. typ.
- External resistor & capacitor required
- Aqueous washable
- Leads for excellent solderability
- Low cost

## APPLICATIONS

- Cellular
- VHF/UHF
- Communications systems



Generic photo used for illustration purposes only

CASE STYLE: DB714

### +RoHS Compliant

The +Suffix identifies RoHS Compliance. See our web site for RoHS Compliance methodologies and qualifications

## ELECTRICAL SPECIFICATIONS AT 25°C

Parameter	Frequency (MHz)	Min.	Typ.	Max.	Unit
Frequency Range		5		1000	MHz
Insertion Loss, above 3.0 dB	5 - 50	—	0.3	0.9	dB
	50 - 500	—	0.5	0.9	
	500 - 1000	—	0.5	1.4	
Isolation	5 - 50	17	25	—	dB
	50 - 500	16	25	—	
	500 - 1000	16	21	—	
Phase Unbalance	5 - 50	—	—	4.0	Degree
	50 - 500	—	—	4.0	
	500 - 1000	—	—	6.0	
Amplitude Unbalance	5 - 50	—	—	0.6	dB
	50 - 500	—	—	0.6	
	500 - 1000	—	—	0.3	

## MAXIMUM RATINGS

Parameter	Ratings
Operating temperature	-40°C to 85°C
Storage temperature	-55°C to 100°C
RF Power Input (as splitter)	0.5 W max.

Permanent damage may occur if any of these limits are exceeded.

## FUNCTIONAL SCHEMATIC

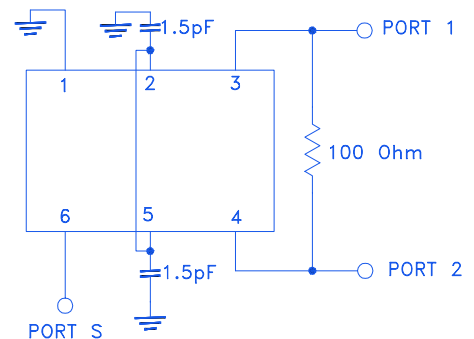

REV. K  
ECO-012587  
TCP-2-10+  
AD/RS/CP/AM  
220322





**SURFACE MOUNT**

# Power Splitter/Combiner **TCP-2-10+**

## PIN CONNECTIONS

SUM PORT	6
PORT 1	3
PORT 2	4
GROUND	1
CONNECT	2,5
EXT. RESISTOR 100Ω	3,4
EXT. CAPACITOR 1.5pF	2 OR 5 TO GND

**PRODUCT MARKING:** N/A

**DEMO BOARD MCL P/N:** TB-232  
**SUGGESTED PCB LAYOUT (PL-001)**

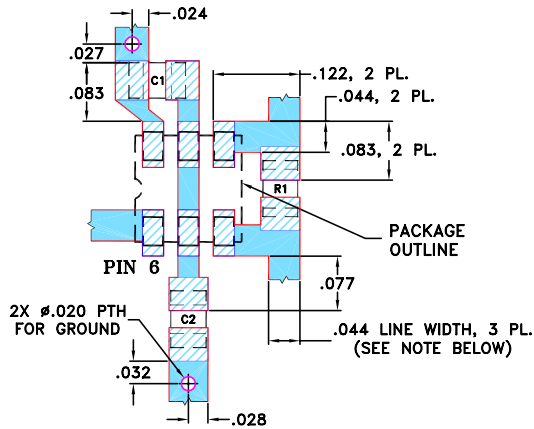

RESISTOR R1: 100 Ohm, 0805 SIZE  
 CAPACITORS C1 & C2: 1.5 pF, 0805 SIZE

NOTES: 1. TRACE WIDTH IS SHOWN FOR ROGERS RO4350B WITH DIELECTRIC THICKNESS 0.020" ± 0.0015"; COPPER: 1/2 OZ. EACH SIDE. FOR OTHER MATERIALS TRACE WIDTH MAY NEED TO BE MODIFIED.

2. BOTTOM SIDE OF THE PCB IS CONTINUOUS GROUND PLANE.

- DENOTES PCB COPPER LAYOUT WITH SMOBC (SOLDER MASK OVER BARE COPPER)
- DENOTES COPPER LAND PATTERN FREE OF SOLDER MASK

## OUTLINE DRAWING

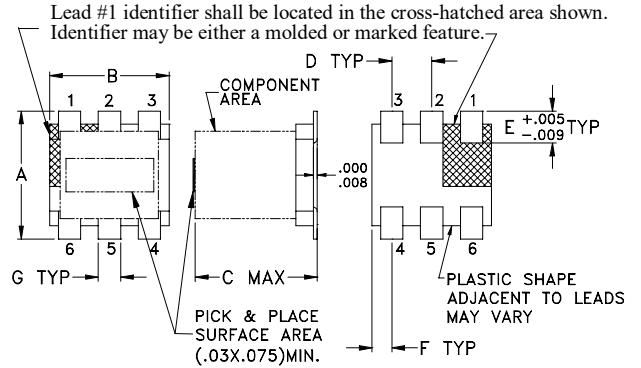

## PCB Land Pattern

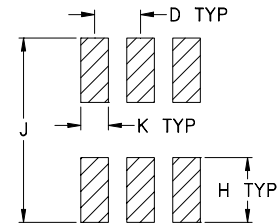

Suggested Layout,  
 Tolerance to be within ±.002

## OUTLINE DIMENSIONS (Inches mm)

A	B	C	D	E	F
.160	.150	.160	.050	.040	.025
4.06	3.81	4.06	1.27	1.02	0.64
G	H	J	K	wt	
.028	.065	.190	.030	grams	
0.71	1.65	4.83	0.76	0.15	

## TAPE & REEL INFORMATION: F47



SURFACE MOUNT

# Power Splitter/Combiner TCP-2-10+

Mini-Circuits

### TYPICAL PERFORMANCE DATA AT 25°C

Frequency (MHz)	Total Loss <sup>1</sup> (dB)		Amplitude Unbalance (dB)	Isolation (dB)	Phase Unbalance (deg.)	VSWR (:1)		
	S-1	S-2				S	1	2
5.00	3.10	3.24	0.14	32.43	0.15	1.02	1.11	1.14
6.00	3.10	3.24	0.14	32.64	0.15	1.02	1.11	1.14
8.00	3.10	3.24	0.14	32.81	0.09	1.02	1.10	1.14
10.00	3.11	3.24	0.13	32.85	0.09	1.02	1.10	1.14
25.00	3.12	3.25	0.14	32.38	0.01	1.02	1.10	1.14
40.00	3.13	3.27	0.14	31.84	0.06	1.02	1.10	1.14
60.00	3.13	3.28	0.14	31.23	0.09	1.03	1.10	1.13
90.00	3.15	3.29	0.14	30.38	0.10	1.03	1.10	1.13
120.00	3.16	3.30	0.14	29.54	0.11	1.04	1.09	1.13
200.00	3.19	3.33	0.14	27.50	0.24	1.05	1.09	1.11
400.00	3.27	3.40	0.13	23.84	0.45	1.07	1.06	1.06
600.00	3.37	3.48	0.11	21.78	0.71	1.09	1.05	1.02
800.00	3.49	3.58	0.09	20.95	0.98	1.09	1.08	1.09
900.00	3.55	3.63	0.08	21.06	1.15	1.09	1.12	1.14
1000.00	3.63	3.70	0.07	21.68	1.29	1.08	1.16	1.20

1. Total Loss = Insertion Loss + 3dB splitter loss.

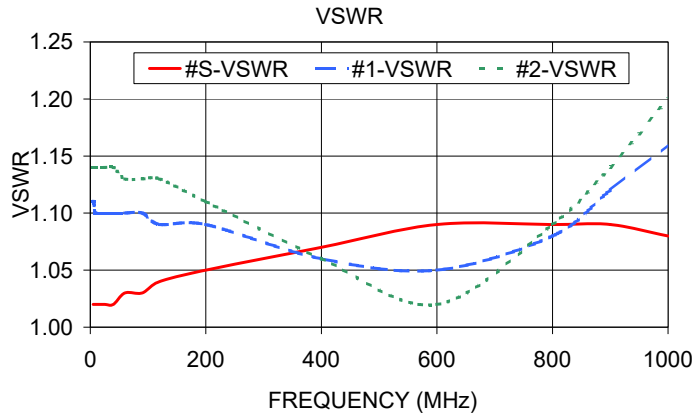
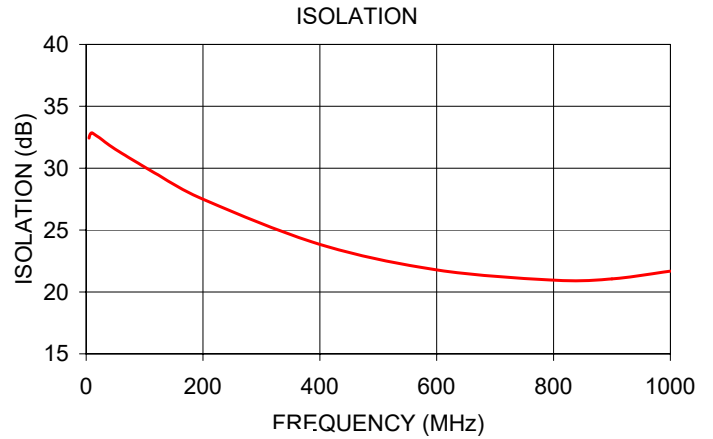
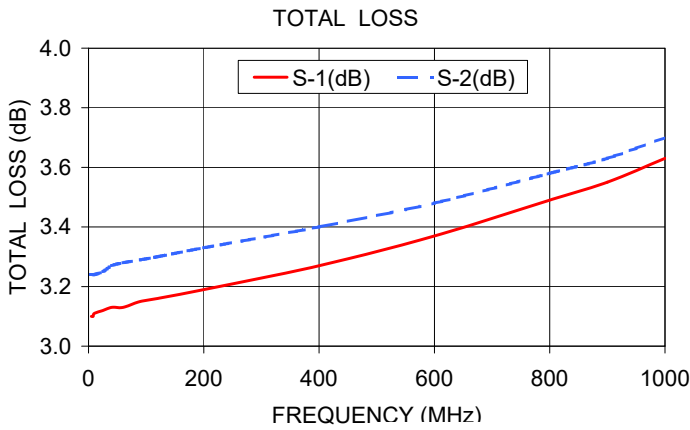

#### NOTES

- A. Performance and quality attributes and conditions not expressly stated in this specification document are intended to be excluded and do not form a part of this specification document.
- B. Electrical specifications and performance data contained in this specification document are based on Mini-Circuit's applicable established test performance criteria and measurement instructions.
- C. The parts covered by this specification document are subject to Mini-Circuits standard limited warranty and terms and conditions (collectively, "Standard Terms"); Purchasers of this part are entitled to the rights and benefits contained therein. For a full statement of the standard. Terms and the exclusive rights and remedies thereunder, please visit Mini-Circuits' website at [www.minicircuits.com/terms/viewterm.html](http://www.minicircuits.com/terms/viewterm.html)



# 2 Way-0° Power Splitter/Combiner

# TCP-2-10+

## Typical Performance Data

TEST CONDITIONS: INPUT POWER = 0dBm @Temperature = +25°C

FREQ. (MHz)	TOTAL LOSS <sup>1</sup> (dB)		AMP. UNBAL. (dB)	PHASE UNBAL. (deg.)	ISOLATION (dB)	VSWR (:1)		
	S-1	S-2				S	1	2
5	3.26	3.11	0.15	0.37	30.06	1.03	1.17	1.14
6	3.26	3.11	0.14	0.32	30.60	1.03	1.17	1.13
7	3.26	3.11	0.14	0.27	31.14	1.03	1.16	1.13
8	3.26	3.12	0.14	0.22	31.69	1.02	1.15	1.12
9	3.26	3.12	0.14	0.17	32.23	1.02	1.15	1.12
10	3.26	3.12	0.14	0.14	32.49	1.02	1.14	1.12
20	3.26	3.12	0.14	0.01	33.17	1.02	1.13	1.11
30	3.26	3.12	0.14	0.01	32.77	1.02	1.13	1.11
40	3.27	3.13	0.14	0.01	32.17	1.03	1.13	1.11
50	3.28	3.14	0.14	0.05	31.71	1.03	1.13	1.11
60	3.29	3.15	0.14	0.07	31.24	1.03	1.13	1.11
70	3.29	3.15	0.14	0.08	30.82	1.03	1.13	1.11
80	3.30	3.16	0.15	0.08	30.43	1.03	1.13	1.10
90	3.31	3.16	0.15	0.06	30.07	1.03	1.13	1.10
100	3.31	3.17	0.14	0.08	29.74	1.04	1.13	1.10
150	3.34	3.20	0.13	0.17	28.20	1.04	1.12	1.10
200	3.36	3.22	0.13	0.24	26.90	1.05	1.11	1.09
250	3.38	3.24	0.13	0.29	25.86	1.05	1.10	1.08
300	3.39	3.26	0.13	0.38	24.89	1.05	1.09	1.08
350	3.41	3.27	0.14	0.42	24.11	1.06	1.08	1.07
400	3.43	3.29	0.14	0.46	23.38	1.06	1.07	1.07
450	3.45	3.31	0.14	0.52	22.76	1.06	1.05	1.07
500	3.47	3.33	0.14	0.56	22.24	1.07	1.04	1.07
550	3.49	3.35	0.14	0.64	21.82	1.07	1.04	1.07
600	3.51	3.37	0.14	0.71	21.44	1.07	1.04	1.08
650	3.54	3.40	0.14	0.75	21.14	1.07	1.05	1.09
700	3.56	3.43	0.13	0.86	20.95	1.07	1.07	1.10
750	3.59	3.45	0.14	0.92	20.79	1.07	1.08	1.11
800	3.62	3.48	0.14	0.98	20.68	1.07	1.10	1.12
850	3.65	3.51	0.14	1.05	20.63	1.07	1.12	1.14
900	3.68	3.55	0.14	1.16	20.64	1.07	1.14	1.15
950	3.72	3.58	0.14	1.29	20.64	1.07	1.16	1.17
1000	3.76	3.63	0.13	1.38	20.64	1.07	1.19	1.18

<sup>1</sup> Total Loss = Insertion Loss+ 3dB Splitter Loss

# 2 Way-0° Power Splitter/Combiner

# TTCP-2-10+

## Typical Performance Data

TEST CONDITIONS: INPUT POWER = 0dBm @Temperature = -40°C

FREQ. (MHz)	TOTAL LOSS <sup>1</sup> (dB)		AMP. UNBAL. (dB)	PHASE UNBAL. (deg.)	ISOLATION (dB) 1-2	VSWR (:1)		
	S-1	S-2				S	1	2
5	3.30	3.13	0.17	1.43	25.32	1.05	1.26	1.20
6	3.28	3.13	0.15	1.30	26.23	1.05	1.24	1.18
7	3.27	3.12	0.14	1.16	27.13	1.04	1.22	1.17
8	3.25	3.12	0.13	1.03	28.04	1.04	1.20	1.16
9	3.23	3.12	0.11	0.89	28.95	1.03	1.18	1.15
10	3.23	3.12	0.11	0.80	29.65	1.03	1.17	1.14
20	3.20	3.10	0.09	0.35	34.69	1.02	1.12	1.11
30	3.19	3.10	0.09	0.24	37.26	1.03	1.11	1.10
40	3.19	3.10	0.09	0.19	38.23	1.03	1.10	1.09
50	3.19	3.11	0.09	0.14	38.00	1.03	1.10	1.09
60	3.20	3.11	0.08	0.12	36.78	1.04	1.09	1.08
70	3.20	3.12	0.08	0.08	35.28	1.04	1.09	1.08
80	3.21	3.12	0.09	0.07	33.92	1.05	1.08	1.08
90	3.21	3.13	0.09	0.08	32.77	1.05	1.08	1.07
100	3.21	3.13	0.08	0.08	31.89	1.06	1.08	1.07
150	3.23	3.15	0.08	0.01	30.11	1.06	1.08	1.08
200	3.25	3.17	0.08	0.09	28.13	1.07	1.10	1.07
250	3.26	3.18	0.08	0.07	26.22	1.08	1.08	1.05
300	3.28	3.19	0.08	0.10	25.26	1.08	1.07	1.06
350	3.29	3.21	0.08	0.13	24.09	1.09	1.06	1.06
400	3.30	3.22	0.09	0.13	23.38	1.09	1.05	1.04
450	3.32	3.23	0.09	0.11	22.69	1.10	1.04	1.04
500	3.33	3.24	0.09	0.12	22.16	1.10	1.03	1.05
550	3.34	3.26	0.08	0.14	21.83	1.09	1.03	1.06
600	3.36	3.28	0.08	0.18	21.42	1.09	1.04	1.07
650	3.37	3.29	0.08	0.19	21.22	1.08	1.05	1.09
700	3.39	3.32	0.07	0.30	20.82	1.09	1.06	1.10
750	3.41	3.34	0.08	0.28	20.63	1.08	1.09	1.11
800	3.44	3.36	0.07	0.32	20.58	1.07	1.11	1.13
850	3.46	3.39	0.07	0.33	20.43	1.08	1.13	1.14
900	3.49	3.42	0.07	0.42	20.46	1.07	1.15	1.15
950	3.52	3.45	0.07	0.47	20.28	1.08	1.16	1.17
1000	3.56	3.49	0.07	0.55	20.30	1.07	1.19	1.18

<sup>1</sup> Total Loss = Insertion Loss+ 3dB Splitter Loss

# 2 Way-0° Power Splitter/Combiner

# TCP-2-10+

## Typical Performance Data

TEST CONDITIONS: INPUT POWER = 0dBm @Temperature = +85°C

FREQ. (MHz)	TOTAL LOSS <sup>1</sup> (dB)		AMP. UNBAL. (dB)	PHASE UNBAL. (deg.)	ISOLATION (dB)	VSWR (:1)		
	S-1	S-2				S	1	2
5	3.33	3.14	0.19	0.34	28.68	1.03	1.20	1.15
6	3.33	3.14	0.19	0.29	28.89	1.03	1.20	1.15
7	3.33	3.14	0.19	0.24	29.11	1.03	1.19	1.15
8	3.34	3.15	0.19	0.20	29.32	1.02	1.19	1.15
9	3.34	3.15	0.19	0.15	29.54	1.02	1.19	1.15
10	3.34	3.15	0.19	0.12	29.60	1.02	1.18	1.14
20	3.35	3.16	0.19	0.00	29.37	1.03	1.18	1.14
30	3.35	3.16	0.19	0.02	28.79	1.03	1.18	1.15
40	3.36	3.17	0.19	0.05	28.19	1.04	1.18	1.15
50	3.37	3.18	0.19	0.08	27.78	1.04	1.18	1.15
60	3.37	3.19	0.19	0.09	27.49	1.03	1.18	1.15
70	3.38	3.20	0.19	0.12	27.36	1.02	1.18	1.15
80	3.39	3.20	0.19	0.16	27.34	1.02	1.18	1.15
90	3.40	3.21	0.19	0.16	27.40	1.01	1.18	1.15
100	3.40	3.21	0.19	0.17	27.48	1.02	1.18	1.15
150	3.42	3.24	0.18	0.26	26.66	1.03	1.17	1.13
200	3.45	3.27	0.17	0.35	25.39	1.02	1.14	1.11
250	3.46	3.30	0.16	0.51	25.22	1.02	1.13	1.12
300	3.48	3.31	0.17	0.67	24.21	1.03	1.13	1.11
350	3.50	3.33	0.18	0.75	23.58	1.02	1.11	1.10
400	3.52	3.35	0.17	0.83	23.15	1.03	1.09	1.10
450	3.54	3.38	0.16	0.97	22.51	1.03	1.07	1.09
500	3.57	3.40	0.17	1.07	22.15	1.04	1.06	1.09
550	3.59	3.42	0.17	1.20	21.80	1.04	1.05	1.09
600	3.62	3.45	0.16	1.32	21.46	1.04	1.05	1.09
650	3.64	3.48	0.16	1.41	21.20	1.05	1.06	1.10
700	3.67	3.51	0.16	1.56	21.04	1.05	1.07	1.10
750	3.70	3.54	0.16	1.67	20.92	1.05	1.09	1.11
800	3.74	3.59	0.15	1.82	20.76	1.06	1.10	1.12
850	3.77	3.62	0.15	1.93	20.72	1.06	1.12	1.13
900	3.81	3.67	0.15	2.13	20.68	1.06	1.14	1.15
950	3.85	3.71	0.15	2.29	20.62	1.07	1.16	1.16
1000	3.91	3.76	0.14	2.47	20.62	1.07	1.18	1.17

<sup>1</sup> Total Loss = Insertion Loss+ 3dB Splitter Loss

# 2 Way-0° Power Splitter/Combiner

# TCP-2-10+

## Typical Performance Curves

**Total Loss**

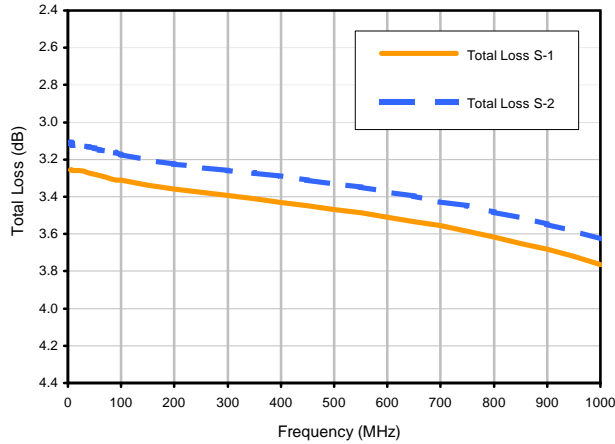

**Total Loss S-1 vs. TEMPERATURE**

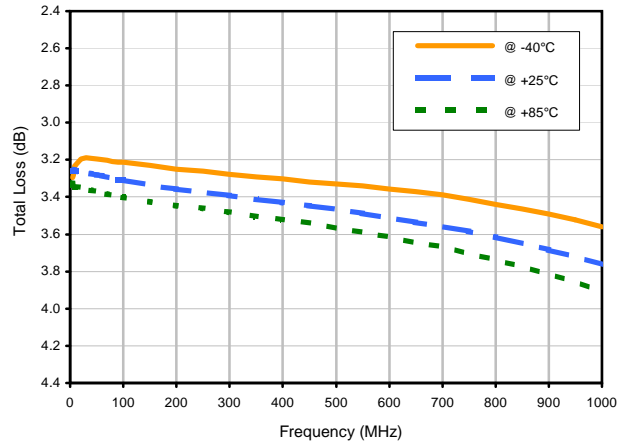

**Amplitude Unbalance vs. TEMPERATURE**

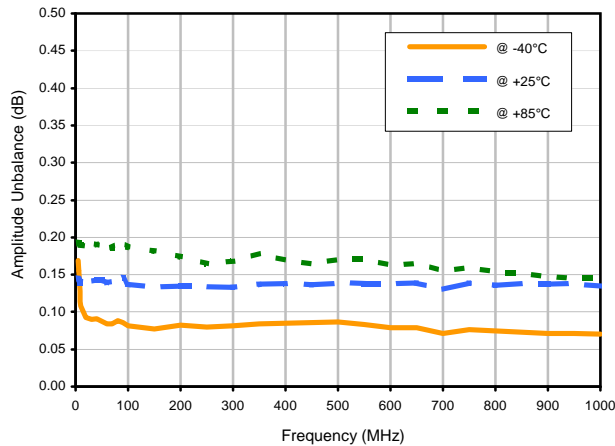

**Phase Unbalance vs. TEMPERATURE**

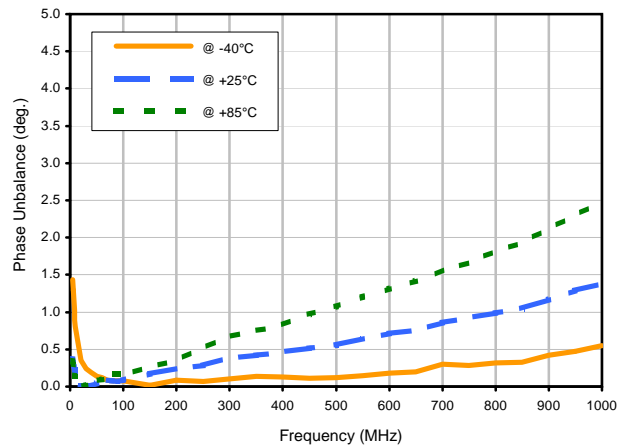

**Isolation 1-2 vs. TEMPERATURE**

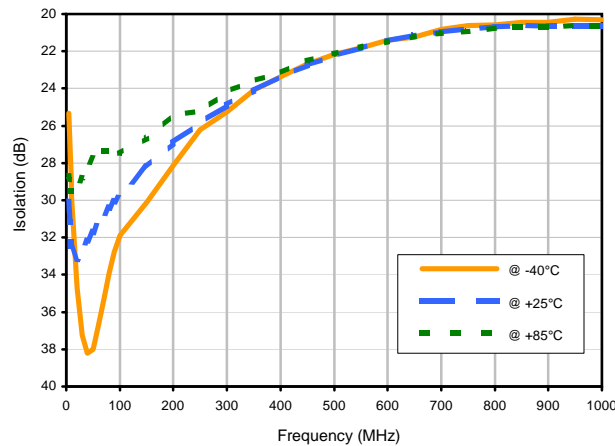

REV. X2  
TCP-2-10+  
100627  
Page 1 of 2



The Design Engineers Search Engine finds the model you need, Instantly • For detailed performance specs & shopping online see [minicircuits.com](http://minicircuits.com)

**Mini-Circuits®**

IF/RF MICROWAVE COMPONENTS • ISO 9001 ISO 14001 AS 9100 CERTIFIED • RoHS compliant  
P.O. Box 350166, Brooklyn, New York 11235-0006 (718) 934-4500 Fax (718) 332-4661

## Typical Performance Curves

VSWR

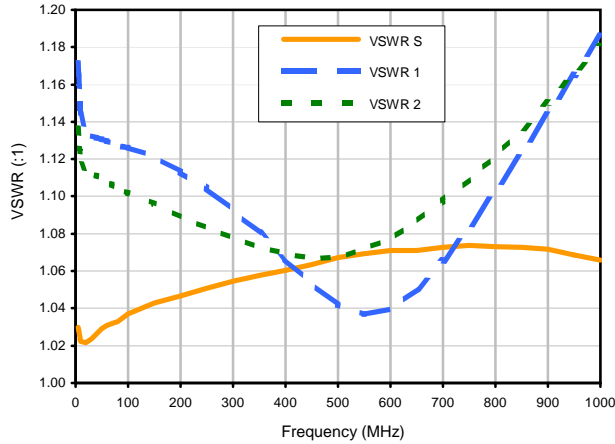

VSWR SUM vs. TEMPERATURE

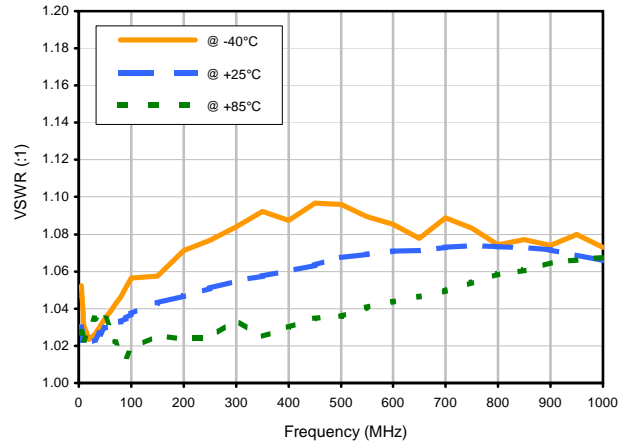

VSWR OUT1 vs. TEMPERATURE

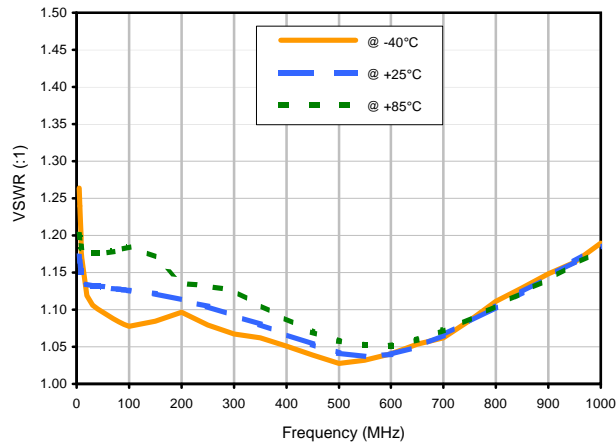



### Outline Dimensions

### PCB Land Pattern

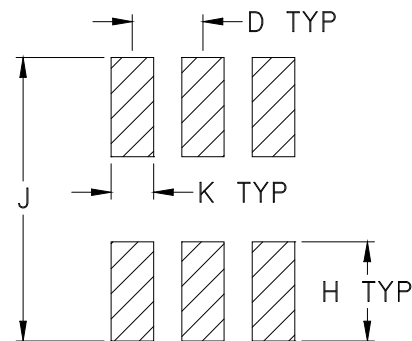
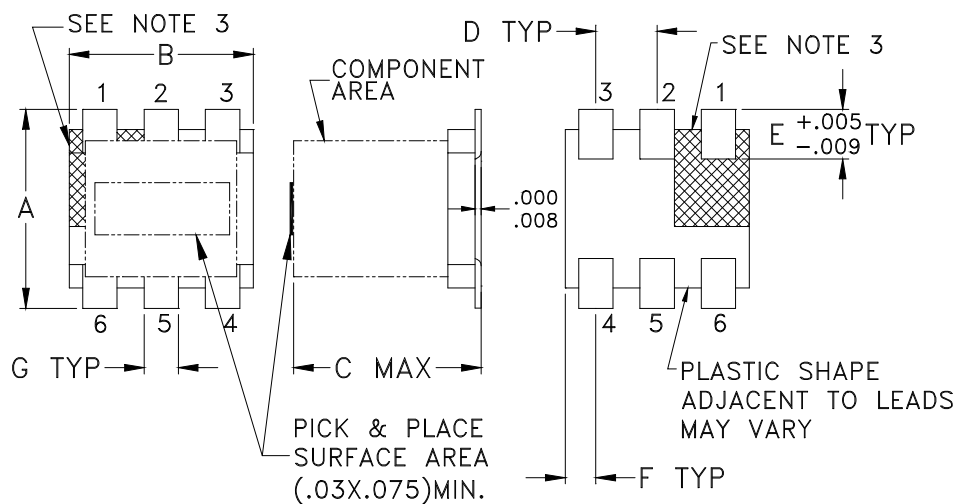

Suggested Layout,  
Tolerance to be within  $\pm 0.002$

CASE #	A	B	C	D	E	F	G	H	J	K	WT. GRAM
DB714	.160 (4.06)	.150 (3.81)	.160 (4.06)	.050 (1.27)	.040 (1.02)	.025 (0.64)	.028 (0.71)	.065 (1.65)	.190 (4.83)	.030 (0.76)	.15

Dimensions are in inches (mm). Tolerances: 2 Pl.  $\pm .01$ ; 3Pl.  $\pm .005$

### Notes:

- Case material: Plastic.
- Termination finish:  
For RoHS Case Styles: Tin plate over Nickel plate. All models, (+) suffix.  
For RoHS-5 Case Styles: Tin-Lead plate. All models, no (+) suffix.
- Lead #1 identifier shall be located in the cross-hatched area shown. Identifier may be either a molded or marked feature.



P.O. Box 350166, Brooklyn, New York 11235-0003 (718) 934-4500 Fax (718) 332-4661 For detailed performance specs & shopping online see Mini-Circuits web site



The Design Engineers Search Engine Provides ACTUAL Data Instantly From MINI-CIRCUITS At: [www.minicircuits.com](http://www.minicircuits.com)

RF/IF MICROWAVE COMPONENTS

# Tape & Reel Packaging TR-F47

## DEVICE ORIENTATION IN T&R

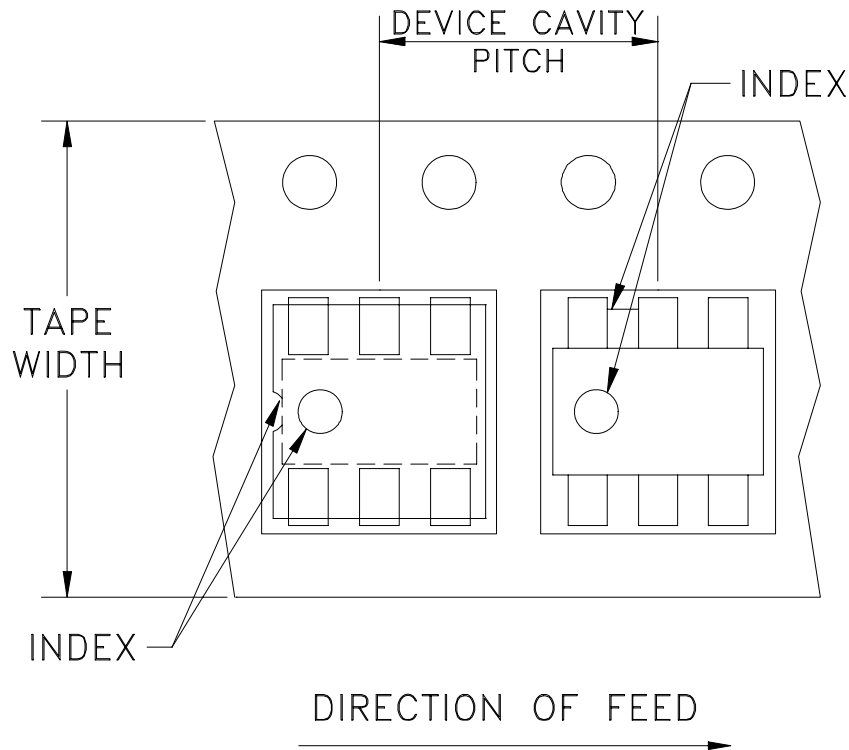

Tape Width, mm	Device Cavity Pitch, mm	Reel Size, inches	Devices per Reel see note
12	8	13	1000, 2000
		7	20, 50, 100, 200, 500

Note: Please consult individual model data sheet to determine device per reel availability.

Mini-Circuits carrier tape materials provide protection from ESD (Electro-Static Discharge) during handling and transportation. Tapes are static dissipative and comply with industry standards EIA-481/EIA-541.

Go to: [www.minicircuits.com/pages/pdfs/tape.pdf](http://www.minicircuits.com/pages/pdfs/tape.pdf)

**Mini-Circuits**<sup>®</sup>

INTERNET <http://www.minicircuits.com>

P.O. Box 350166, Brooklyn, New York 11235-0003 (718) 934-4500 Fax (718) 332-4661

Distribution Centers NORTH AMERICA 800-654-7949 • 417-335-5935 • Fax 417-335-5945 • EUROPE 44-1252-832600 • Fax 44-1252-837010

Mini-Circuits ISO 9001 & ISO 14001 Certified

THIRD ANGLE PROJECTION

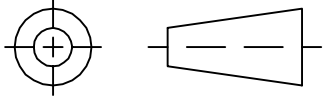

REVISIONS

REV	ECN No.	DESCRIPTION	DATE	DR	AUTH
A	M71500	ADDED SOLDER MASK & LEGEND	04/00	IL	DB
B	M82377	UPDATED DRAWING	08/06/02	GF	HY
C	M83081	UPDATED DRAWING	06/24/03	MMG	DY
D	M102713	ADDED "...WITH SMOBC", CRCTD MATL	01/12/06	GF	IL

SUGGESTED MOUNTING CONFIGURATION FOR DB714 CASE STYLE, "mt" PIN CONNECTION

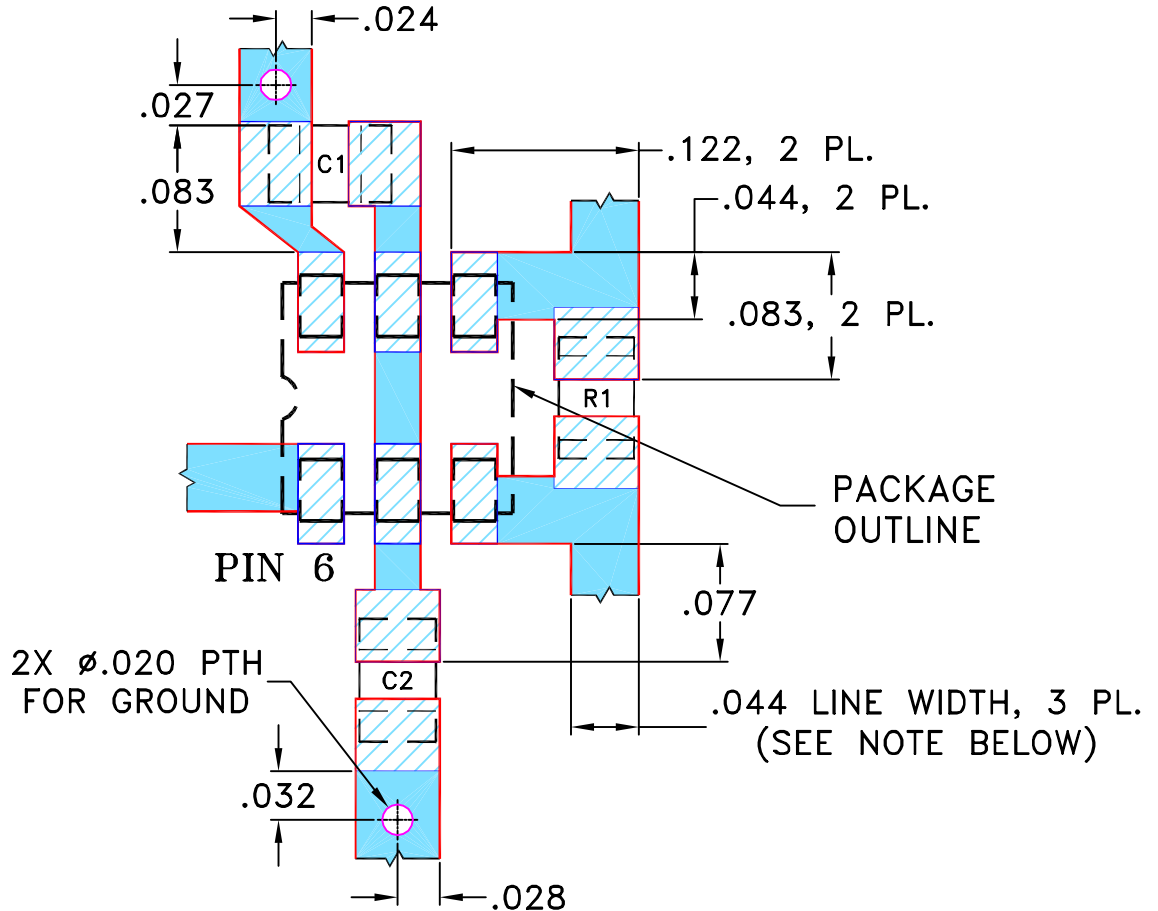

RESISTOR R1: 100 Ohm, 0805 SIZE  
 CAPACITORS C1 & C2: 1.5 pF, 0805 SIZE

NOTES: 1. TRACE WIDTH IS SHOWN FOR ROGERS R04350B WITH DIELECTRIC THICKNESS 0.020" ± 0.0015"; COPPER: 1/2 OZ. EACH SIDE. FOR OTHER MATERIALS TRACE WIDTH MAY NEED TO BE MODIFIED.

2. BOTTOM SIDE OF THE PCB IS CONTINUOUS GROUND PLANE.

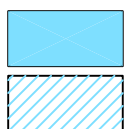

SOLID BLUE DENOTES PCB COPPER LAYOUT WITH SMOBC (SOLDER MASK OVER BARE COPPER)  
 HATCHED BLUE DENOTES COPPER LAND PATTERN FREE OF SOLDER MASK

UNLESS OTHERWISE SPECIFIED	INITIALS	DATE
DRAWN	IL	02/24/00
CHECKED	DY	02/29/00
APPROVED	DB	02/29/00

Mini-Circuits® 13 Neptune Avenue  
 Brooklyn NY 11235

PL, mt, DB714, TCP, TB-232

Mini-Circuits®  
 THIS DOCUMENT AND ITS CONTENTS ARE THE PROPERTY OF MINI-CIRCUITS. EXCEPT FOR USE EXPRESSLY GRANTED, IN WRITING, TO ITS VENDORS, VEEDEE AND THE UNITED STATES GOVERNMENT, MINI-CIRCUITS RESERVES ALL PROPRIETARY DESIGN, USE, MANUFACTURING AND REPRODUCTION RIGHTS THERETO. THESE CONTENTS SHALL NOT BE USED, DUPLICATED OR DISCLOSED TO ANY OUTSIDE PARTY, IN WHOLE OR IN PART, WITHOUT WRITTEN PERMISSION OF MINI-CIRCUITS.

SIZE	CODE IDENT	DRAWING NO:	REV:
A	15542	98-PL-001	D
FILE:	98PL001	SCALE:	8:1
		SHEET:	1 OF 1

# Evaluation Board and Circuit

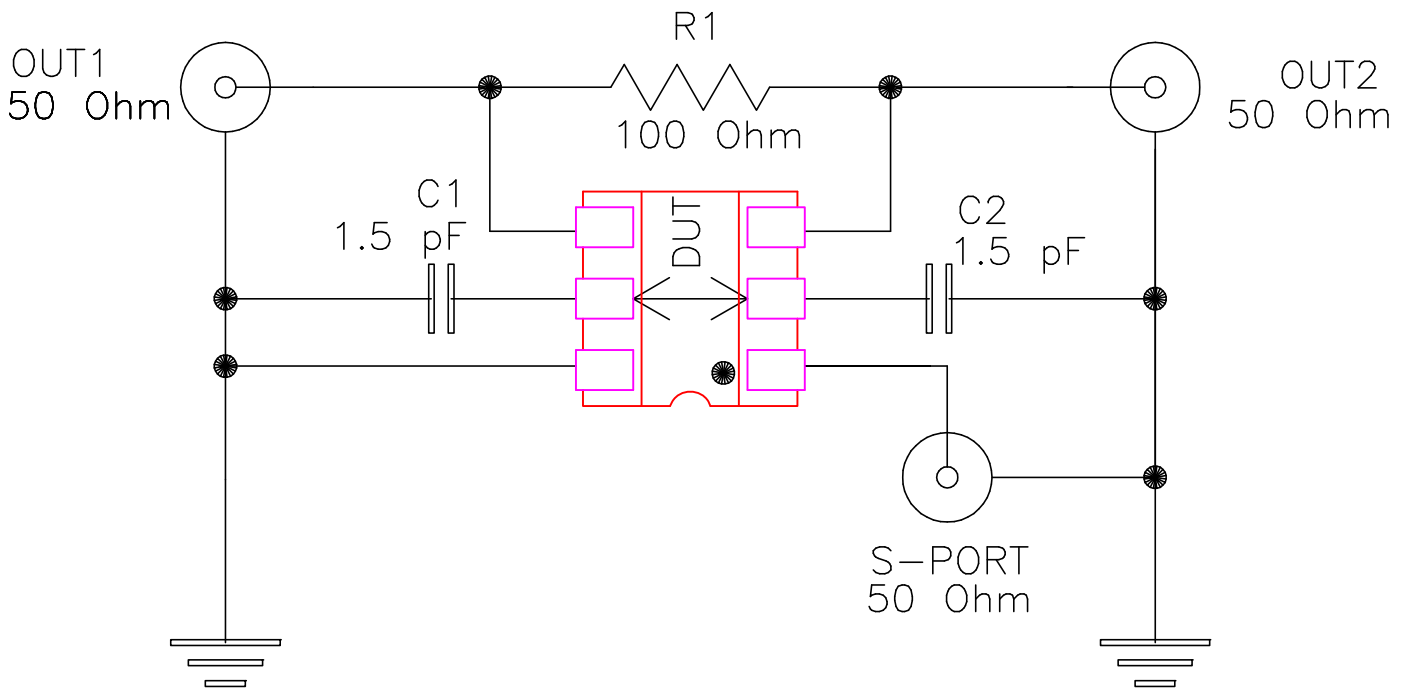
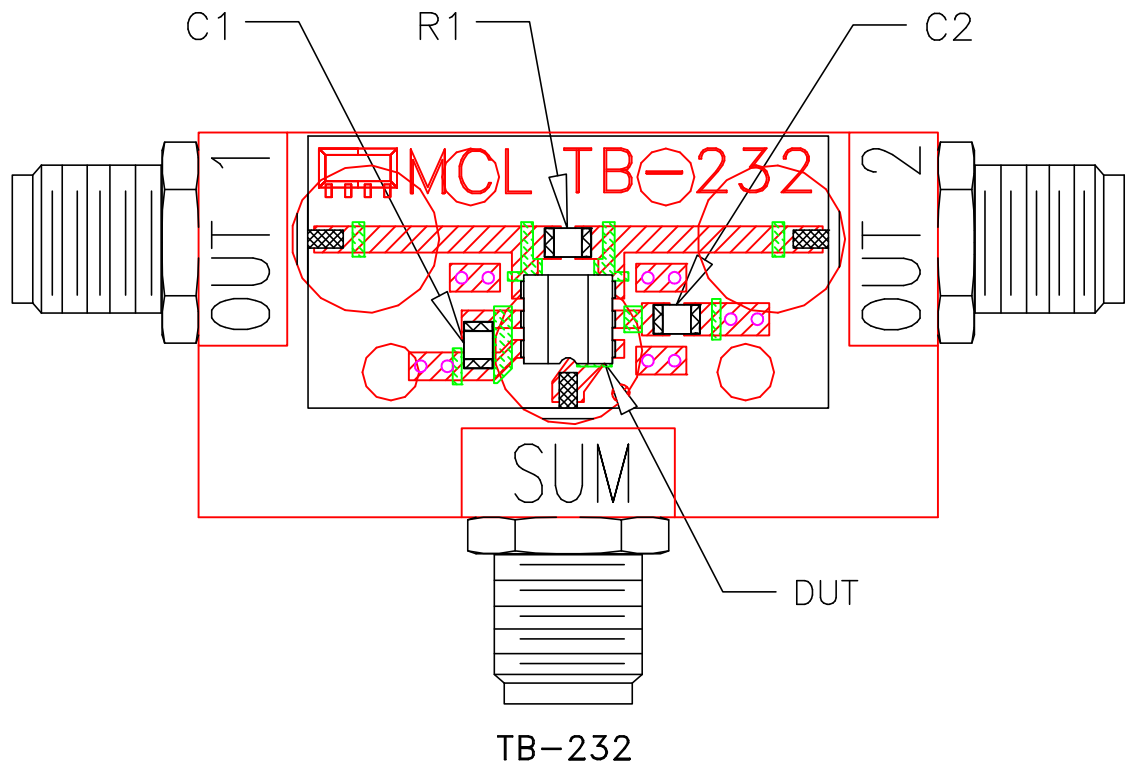

Schematic Diagram

## Notes:

1. SMA Female connectors.
2. PCB Material: Rogers R04350 or equivalent,  
Dielectric Constant=3.5, Thickness=.020 inch.

 **Mini-Circuits®**



All Mini-Circuits products are manufactured under exacting quality assurance and control standards, and are capable of meeting published specifications after being subjected to any or all of the following physical and environmental test.

Specification	Test/Inspection Condition	Reference/Spec
Operating Temperature	-40° to 85°C Ambient Environment	Individual Model Data Sheet
Storage Temperature	-55° to 100° C Ambient Environment	Individual Model Data Sheet
Humidity	90 to 95% RH, 240 hours, 50°C	MIL-STD-202, Method 103, Condition A, Except 50°C and end-point electrical test done within 12 hours
Thermal Shock	-55° to 100°C, 100 cycles	MIL-STD-202, Method 107, Condition A-3, except +100°C
Solder Reflow Heat	Sn-Pb Eutetic Process: 225°C peak Pb-Free Process 245° - 250°C peak	J-STD-020, Table 4-1, 4-2 and 5-2, Figure 5-1
Solderability	10X Magnification	J-STD-002, 95% Coverage
Vibration (High Frequency)	20g peak, 10-2000 Hz, 12 times in each of three perpendicular directions (total 36)	MIL-STD-202, Method 204, Condition D
Mechanical Shock	50g, 11 ms, 1/2-sine, 18 shocks: 3 each direction, each of 3 axes	MIL-STD-202, Method 213, Condition A
Marking Resistance to Solvents	Isopropyl alcohol + mineral spirits at 25°C; terpene defluxer at 25°C; distilled water + proylene glycol monomethyl ether + monoethanolamine at 63°C to 70°C	MIL-STD-202, Method 215