



USB / ETHERNET

Synthesized Signal Generator

SSG-15G-RC

50Ω 0.01 to 15 GHz -50 dBm to +16 dBm

THE BIG DEAL

- Wideband generator with 0.1 Hz frequency resolution
- Internal & external pulse modulation
- 0.5 μs pulse signals
- USB and Ethernet control

APPLICATIONS

- C, X & Ku band radar simulation
- LTE / 5G / WiFi 6E testing
- Dynamic Frequency Selection (DFS) simulation
- High speed RF, Microwave ATE



Model No.	SSG-15G-RC
Case Style	SL2686
RF Connectors	SMA

DOWNLOAD

SOFTWARE PACKAGE

FC, CE, UK & RoHS Compliant

See our web site for RoHS Compliance methodologies and qualifications

PRODUCT OVERVIEW

Mini-Circuits SSG-15G-RC is a wideband synthesized signal generator operating over a frequency range of 10 MHz to 15 GHz. The signal generator is cased in a compact, rugged metal shielded package (5.1" x 3.6" x 1.0") and equipped with an SMA(F) 50Ω connector at the RF output port and starts immediately when power is applied.

Using the supplied software, the user can easily select one of several different output modes including multiple pulse modulation options, frequency sweep, and power sweep (up, down, or bidirectional).

Full software support is provided, including our user-friendly GUI application for Windows and a full API with programming instructions for Windows and Linux environments (both 32-bit and 64-bit systems). The SSG-15G-RC can be controlled from almost any Windows or Linux PC, via USB interface, or any computer with a network interface via HTTP, Telnet or SSH.

Included with the generator are a 6.6 ft. USB cable, two SMB-BNC cables for trigger and reference, and a 6V power adapter. See "Ordering Information" on the last page for more details.

KEY FEATURES

Feature	Advantages
Pulse modulation options	The SSG-15G-RC can produce pulse modulated RF signals using an internal or external modulating pulse.
Multiple sweep options	The SSG-15G-RC can be set to sweep either power or frequency up, down, or bidirectionally.
USB & Ethernet control	USB HID and Ethernet (HTTP / Telnet / SSH) interfaces provide easy compatibility with a wide range of software setups and programming environments.
Full software support	User friendly Windows GUI (graphical user interface) allows manual control straight out of the box, while the comprehensive API (application programming interface) with examples and instructions allows easy automation in most programming environments

Trademarks:

Windows is a registered trademark of Microsoft Corporation in the United States and other countries ; Linux is a registered trademark of Linus Torvalds ; Pentium is a registered trademark of Intel Corporation. Neither Mini-Circuits nor the Mini-Circuits products are affiliated with or endorsed by the owners of the referenced trademarks. Mini-Circuits and the Mini-Circuits logo are registered trademarks of Scientific Components Corporation.





ELECTRICAL SPECIFICATIONS AT +25°C

Parameter	Condition (GHz)		Min.	Typ.	Max.	Unit
Output Frequency	-		0.01		15	GHz
Frequency Resolution ¹	0.01 - 15 GHz		-	0.1	-	Hz
Frequency accuracy	Using Internal Reference		-	±1	-	ppm
Settling time ^{2,4}	Hop Mode ³		-	0.2	0.3	ms
	Freq. Sweep ³		-	0.6	0.8	
	PC (External) Control		-	1.2	5	
Dwell time (nominal) ^{4,5}	-		0.1	-	10,000	ms
VSWR	0.01 - 4.9 GHz		-	1.40	-	:1
	4.9 - 10 GHz		-	1.50	-	
	10 - 15 GHz		-	2.10	-	
Output power Max ⁶	0.01 - 0.05 GHz		+3	+8	-	dBm
	0.05 - 15 GHz		+10	+16	-	
Output power Min ⁶	0.01 - 4.8 GHz		-	-50	-45	dBm
	4.8 - 15 GHz		-	-48	-43	
Power resolution (nominal) ⁷	0.01 - 15 GHz		-	0.1	-	dB
Output power accuracy ⁶	0.01 - 0.05 GHz	-45 dBm to +3 dBm	-	±0.50	-	dB
		-45 dBm to -35 dBm	-	±0.60	-	
	0.05 - 5 GHz	-35 dBm to -14 dBm	-	±0.75	-	
		-14 dBm to +5 dBm	-	±0.55	-	
	5 - 12 GHz	+5 dBm to +10 dBm	-	±0.90	-	
		-45 dBm to -21 dBm	-	±0.70	-	
	12 - 15 GHz	-21 dBm to +10 dBm	-	±0.80	-	
		-45 dBm to -21 dBm	-	±0.70	-	
RF output level	0.01 - 7 GHz	RF off	-	-95	-	dBm
	7 - 15 GHz		-	-75	-	
Harmonics ⁶	0.01 - 2 GHz	-45 dBm to +10 dBm	-	-9	-	dBc
	2 - 4.9 GHz		-	-25	-	
	4.9 - 10 GHz		-	-20	-	
	10 - 15 GHz		-	-30	-	
Non-Harmonic Spurious	-		-	-70	-	dBc
Ethernet Communication	Protocol		TCP / IP, HTTP, Telnet, SSH, DHCP, UDP (limited)			
	Max Data Rate		100 Mbps (100 Base-T Full Duplex)			
USB Communication	Protocol		HID (Human Interface Device) - High Speed			
	Min Communication Time ⁸		400 µs typ (full transmit/recieve cycle)			

1. Frequency resolution is tested with 10 MHz external reference.
 2. Settling time - transition time between 2 output states. During the transition, RF output is turned off to avoid transient outputs.
 3. For sweep / hop sequences pre-loaded into internal memory (high-speed mode).
 4. Generator response time is Dwell time + Settling time.
 5. Dwell time - duration of each signal point in a Sweep or Hop sequence set by user. Default is minimum dwell time.
 6. The generator is calibrated within typical power range, however performance is guaranteed only within power max/min limits.
 7. At power steps below 0.5 dB increased non-monotonic behavior may be observed.
 8. USB min communication time is based on the polling interval of the USB HID protocol (125 µs polling interval, 1024 bytes per packet), medium CPU load and no other high-speed USB devices using the USB bus.

**REGULAR PULSE MODULATION SPECIFICATIONS AT +25°C**

Repetitive RF pulse sequences with fixed freq. and power, supporting internal or external modulation and input / output trigger options.

Parameter	Condition	Min.	Typ.	Max.	Unit
Pulse Width resolution	Nominal value	0.05	-	-	μs
Pulse width ^{9, 12}	Measured at the 50% of pulse level	0.5	-	10e6	μs
Pulse period ⁹	Measured at the 50% of pulse level	2	-	10e6	μs
Duty cycle (in Free Run)	Pulse Width divided by Pulse Period	0.0001	-	99.9999	%
Rise / Fall time ¹¹	Measured between 10% and 90% of pulse level	-	100 / 20	-	ns
Pulse Width Accuracy ¹²	Measured at 50% of pulse level	Internal pulse modulation	±3	-	%
		External pulse modulation	±3	-	
External pulse modulation input threshold	External pulse modulation	-	-	3	V
Trigger response delay	Trigger edge to 50% of pulse level	-	1	-	μs
Pulse Power ratio	PWR _{OUT} = 0 dBm, FREQ _{OUT} = 10 MHz	-	58	-	dB
	PWR _{OUT} = +10 dBm, FREQ _{OUT} = 15 GHz	-	50	-	

DYNAMIC PULSE MODULATION SPECIFICATIONS AT +25°C

Flexible RF pulse sequences with varying frequency, power, pulse width and pulse repetition interval (PRI).

Parameter	Condition	Min.	Typ.	Max.	Unit	
Pulse Width resolution	Nominal value	0.05	-	-	μs	
Pulse width ¹²	Measured at the 50% of pulse level	0.5	-	4e6	μs	
Pulse Interval	Fixed freq. & Power	Measured at the 50% of pulse level	4.5	-	4e6	μs
	Fixed frequency	Measured at the 50% of pulse level	7	-	4e6	
	Varying frequency	Measured at the 50% of pulse level	150	-	4e6	
Duty cycle (in Free Run)	Pulse Width divided by Pulse Period	0.0001	-	99.9999	%	
Rise / Fall time ¹¹	Measured between 10% and 90% of pulse level	-	100 / 20	-	ns	
Pulse Width Accuracy ¹²	Measured at 50% of pulse level	-	±3	-	%	
Pulse Power ratio	PWR _{OUT} = 0 dBm, FREQ _{OUT} = 10 MHz	-	58	-	dB	
	PWR _{OUT} = +10 dBm, FREQ _{OUT} = 15 GHz	-	50	-		

9. Pulse width must be less than pulse period by at least 0.5 μs.

10. Pulse widths below 0.5 μs can be set, however performance is only guaranteed for 0.5 μs and up.

11. Pulse rise time will increase with pulse interval under 3 μs.

12. Pulse width accuracy is 3% of pulse width, or ±100 ns, whichever is greater.

**TYPICAL PHASE NOISE (SSB) AT +25°C**

Carrier Frequency (GHz)	Frequency Offset (dBc / Hz)				
	100 Hz	1 kHz	10 kHz	100 kHz	1 MHz
0.01	-130	-135	-140	-146	-147
0.05	-116	-130	-140	-143	-157
0.10	-108	-127	-137	-137	-159
0.20	-106	-122	-131	-131	-155
0.40	-97	-116	-124	-125	-150
0.80	-91	-109	-118	-118	-144
1.60	-83	-103	-112	-112	-138
3.20	-81	-97	-106	-106	-129
4.00	-78	-95	-105	-105	-132
5.00	-75	-94	-103	-102	-129
6.40	-73	-92	-100	-100	-123
8.00	-70	-90	-98	-98	-123
10.00	-69	-90	-96	-96	-123
12.80	-67	-90	-95	-94	-118
15.00	-66	-89	-92	-92	-116

REFERENCE, TRIGGER & DC POWER AT +25°C

Parameter	Condition	Min.	Typ.	Max.	Unit
Aging	Using Internal Reference	-	2	-	ppm/yr
Reference In	Frequency	-	10	-	MHz
	Power	-3.5	-	+7.5	dBm
	Phase Noise	10kHz Offset	-	-145	-
Reference Out	Frequency	-	10	-	MHz
	Frequency Accuracy	Using Internal Reference	±1	-	ppm
	Power	-	±5.5	-	dBm
Trigger Out ¹³	Low	0	-	0.4	V
	High	3	-	5	
Trigger In	Low	0	-	0.4	
	High	3	-	5	
Supply Voltage	-	5.6	6	6.4	V _{DC}
Supply Current ¹⁴	-	-	1250	1850	mA
USB Current ¹⁴	-	-	0	-	

13. Trigger out voltage specified with impedance load of 10 kΩ minimum.

14. All power is drawn from power adaptor, USB is used for control only.

**ABSOLUTE MAXIMUM RATINGS**

Operating Temperature	0°C to 50°C	
Storage Temperature	-20°C to 60°C	
Power in @ Reference In	+10 dBm	
Reverse Power (DC) @ Reference Out	8 V _{DC}	
Reverse Power (DC) @ RF Out	16 V _{DC}	
Reverse Power (RF) @ RF Out	0.01 - 0.1 GHz	Derates linearly from +22 dBm at 100 MHz to +13 dBm at 10 MHz
	0.1 - 15 GHz	+22 dBm
Voltage input to Trigger ports	-0.3V _{DC} to +5.5V _{DC}	

Permanent damage may occur if any of these limits are exceeded. Operating in the range between operating power limits and absolute maximum ratings for extended periods of time may result in reduced life and reliability.

CONNECTIONS

Port Name	Connector Type
RF Output	J1 SMA-Female
Reference In	J4 SMB-Male
Reference Out	J5 SMB-Male
Trigger In	J3 SMB-Male
Trigger Out	J2 SMB-Male
Power In ¹⁵	2.1 mm DC socket
USB Port	USB type Mini-B female
Network (Ethernet/LAN)	RJ45 socket
Auxiliary Control (FX-30G-RC)	Snap Fit

15. No power On/Off switch - SSG will power on as soon as power is connected, starting at the specified startup condition (factory default set to 15 GHz, -45 dBm, RF Off).



OUTLINE DRAWING (SL2686)

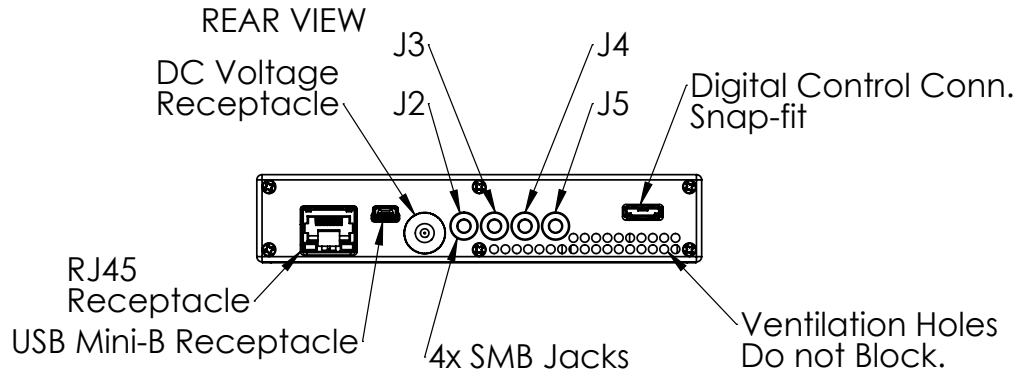

TOP VIEW

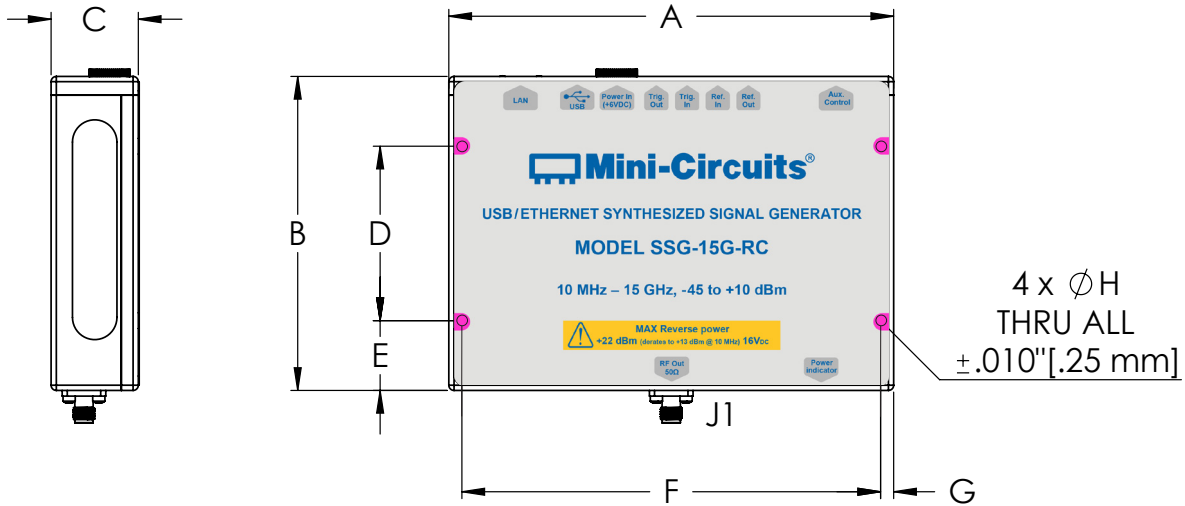

FRONT VIEW

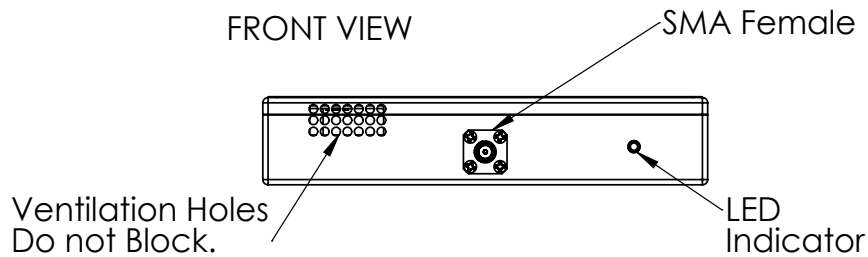

OUTLINE DIMENSIONS (INCH / MM)

A	B	C	D	E	F	G	H	weight
5.10	3.60	1.00	2.00	0.80	4.80	0.15	0.125	(grams)
129.50	91.40	25.40	50.80	20.32	121.92	3.81	3.180	600



TYPICAL PERFORMANCE CURVES

Max Power Output vs. Frequency

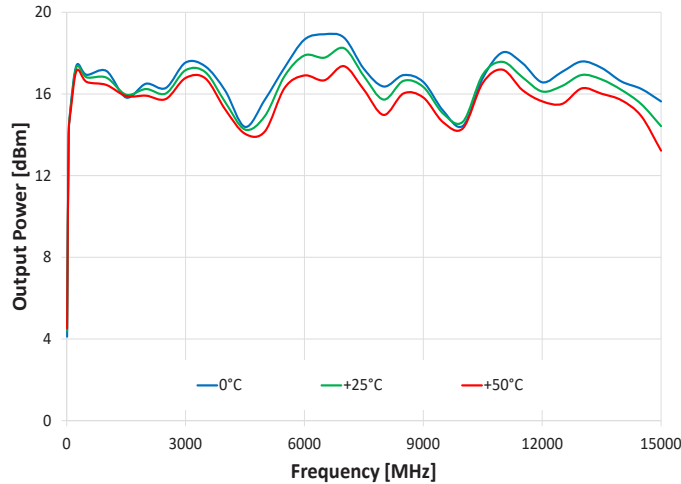

Power Accuracy vs. Frequency

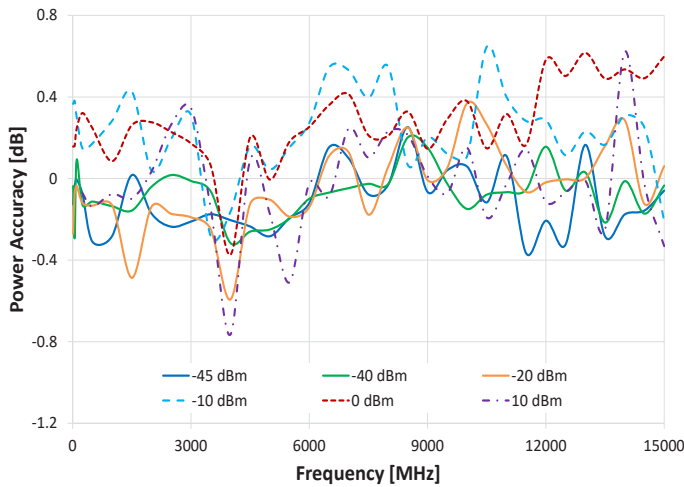

Power Accuracy vs. Output Power

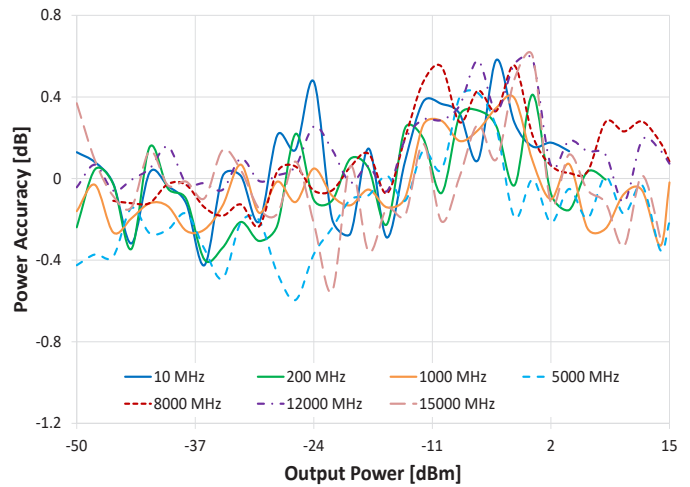

Phase Noise vs. Frequency at selected Freq. Offsets

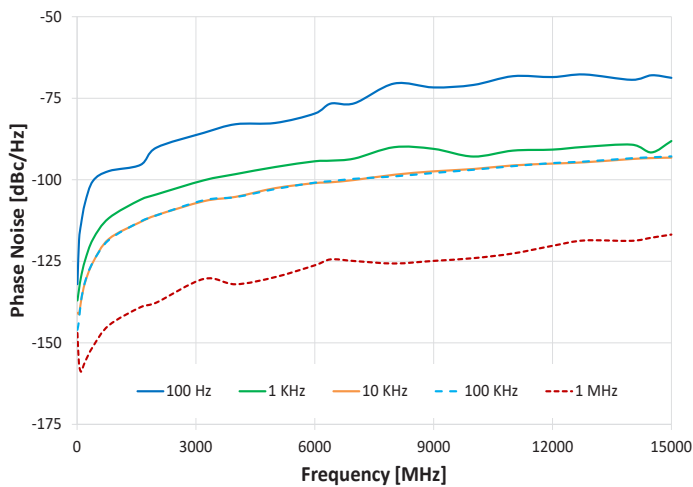

Phase Noise vs. Freq. Offset at selected output frequencies

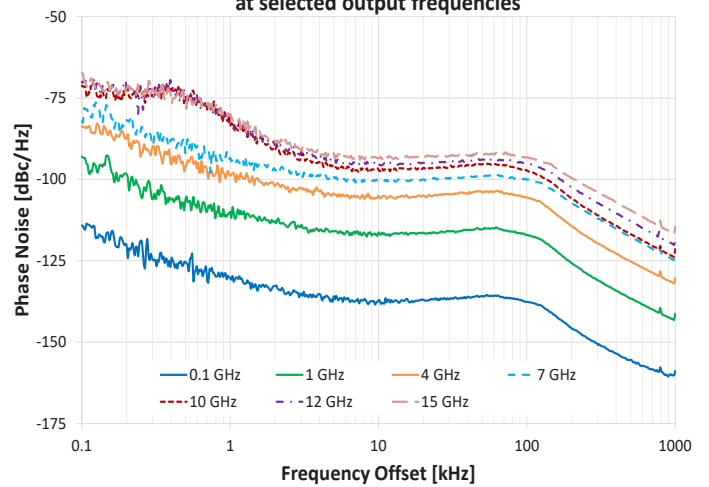



TYPICAL PERFORMANCE CURVES (CONTINUED)

Harmonics vs. Frequency @ PWR = -40 dBm

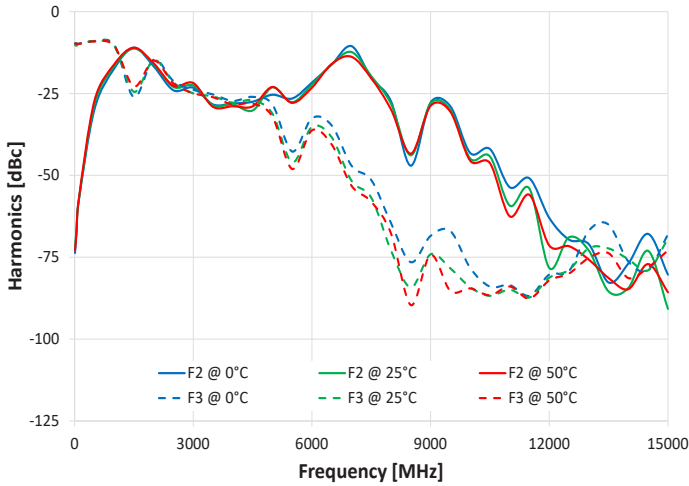

Harmonics vs. Frequency @ PWR = -20 dBm

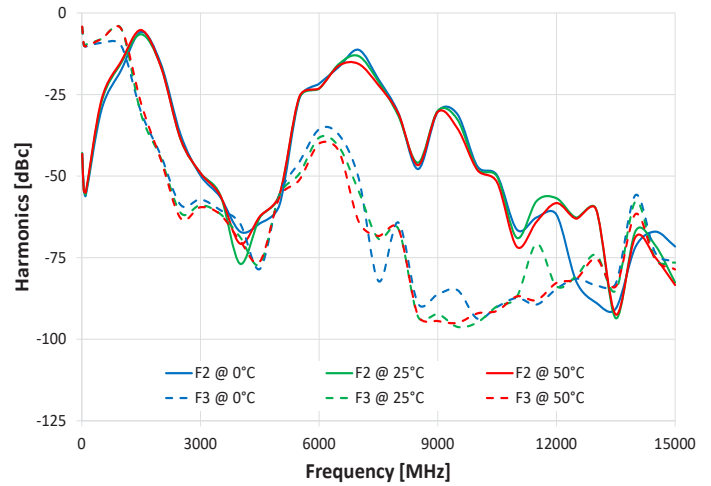

Harmonics vs. Frequency @ PWR = 0 dBm

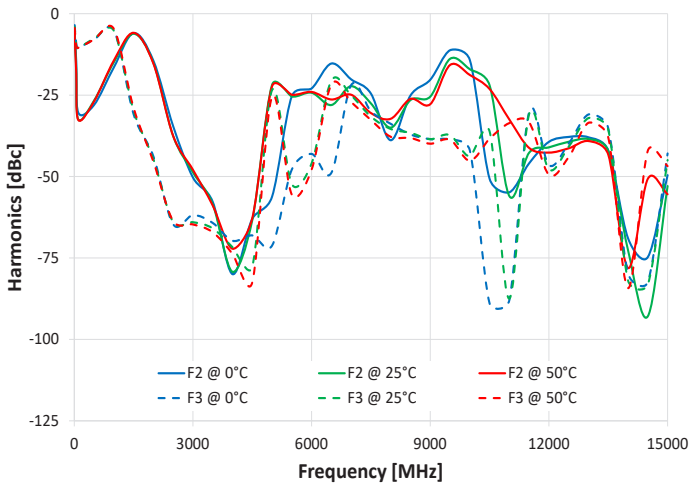

Harmonics vs. Frequency @ PWR = +10 dBm

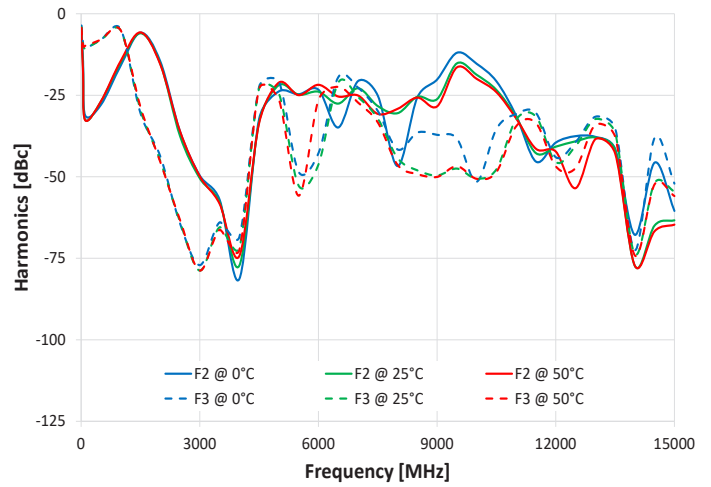

Spurious @ ±100 kHz to 50 MHz offset vs. Frequency @ PWR = +5 dBm

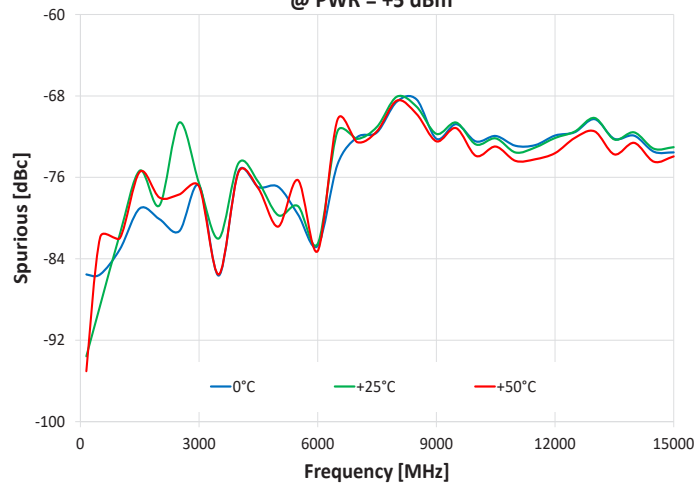

**SOFTWARE SPECIFICATIONS****SOFTWARE & DOCUMENTATION DOWNLOAD:**

- Mini-Circuits' full software and support package including user guide, Windows GUI, DLL files, programming manual and examples can be downloaded free of charge from: <https://www.minicircuits.com/softwaredownload/sg.html>
- Please contact testsolutions@minicircuits.com for support

MINIMUM SYSTEM REQUIREMENTS:

Parameter	Requirements	
Interface	USB HID or HTTP Get/Post or Telnet protocols or SSH protocols	
System Requirements	GUI	Windows 7 or later
	USB API DLL	Windows 7 or later and programming environment with ActiveX or .NET support
	USB Direct Programming	Linux, Windows 7 or later
	HTTP, Telnet or SSH	Any computer with a network port and Ethernet-TCP/IP (HTTP, Telnet or SSH protocols) support
Hardware	Pentium II or later with 256 MB RAM	

APPLICATION PROGRAMMING INTERFACE (API)**ETHERNET SUPPORT:**

- Simple ASCII / SCPI command set for unit control
- Communication via HTTP or Telnet
- Supported by most common programming environments

USB SUPPORT (WINDOWS):

- ActiveX COM DLL file for creation of 32-bit programs
- .NET library DLL file for creation of 32 / 64-bit programs
- Supported by most common programming environments (refer to application note [AN-49-001](#) for summary of supported environments)

USB SUPPORT (LINUX):

- Direct USB programming using a series of USB interrupt codes



GRAPHICAL USER INTERFACE (GUI) FOR WINDOWS - KEY FEATURES

- Connect via USB or Ethernet
- Password protected access for safe remote usage over Ethernet

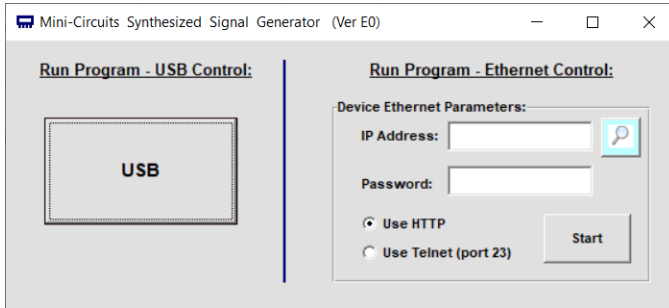



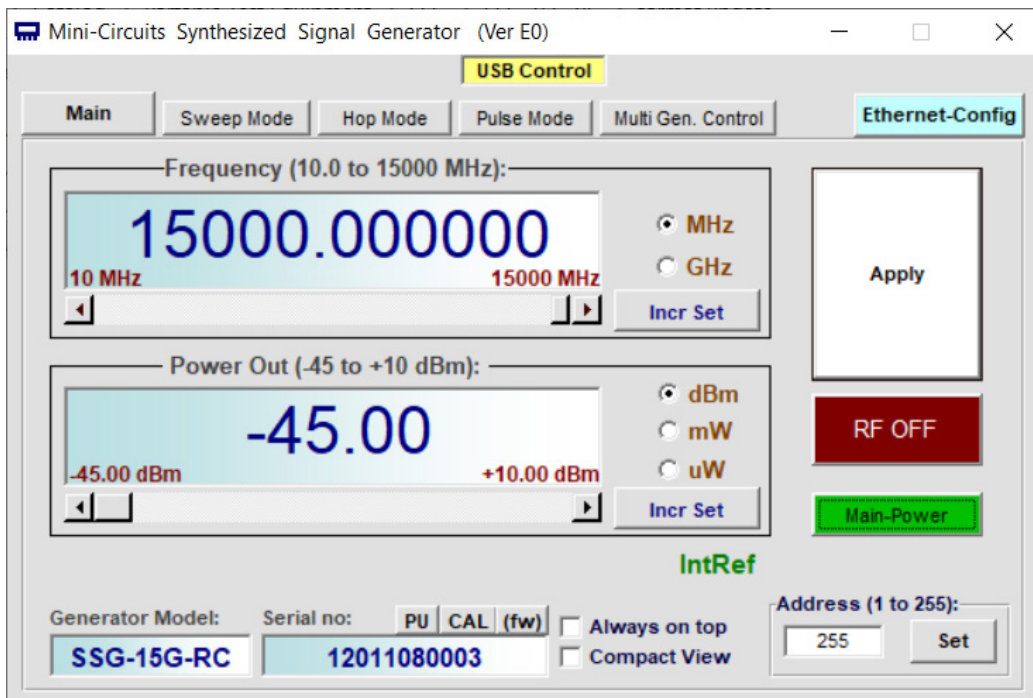





- Configure output power, frequency, pulse modulation
- Program timed signal output sequences (linear sweep and frequency hop)
- Control timed sequences in multiple generators simultaneously
- Track unit operation time since last calibration and setup calibration reminders



**ORDERING INFORMATION**Please contact Mini-Circuits' Test Solutions department for price and availability: testsolutions@minicircuits.com

Model	Description
SSG-15G-RC	USB/Ethernet Synthesized Signal Generator

Included Accessories	Part No.	Description
	AC/DC-6-3W	AC/DC Grounded Power adapter, 0°C to +40°C AC Input: 100-240 V, 50/60 Hz, $I_{Max} = 1.2A$ DC Output $6\pm 0.3 V$, $I_{Max} = 3A$
	CBL-3W-xx	AC Power Cord (Select one power cord from below with each unit)
	MUSB-CBL-7FR+	6.6 ft (2.0 m) USB Cable: USB type A (Male) to USB type Mini-B (Male) with ferrite
	CBL-5FT-BMSMB+	2 x 5 ft (1.5 m) Trigger cable: BNC (male) to SMB (Female)

AC Power Cords ¹⁶	Part No.	Description
	CBL-3W-US	Power Cord for United States
	CBL-3W-EU	Power Cord for Europe
	CBL-3W-UK	Power Cord for United Kingdom
	CBL-3W-AU	Power Cord for Australia and China
	CBL-3W-IL	Power Cord for Israel

16. Power cords for other countries are also available, if you need a power cord for a country not listed in the table please contact testsolutions@minicircuits.com

OPTIONAL ACCESSORIES

MUSB-CBL-3FR+	3.3 ft (1.0 m) USB Cable: USB type A (Male) to USB type Mini-B (Male) with ferrite
MUSB-CBL-7FR+ (spare)	6.6 ft (2.0 m) USB Cable: USB type A (Male) to USB type Mini-B (Male) with ferrite
CBL-RJ45-MM-5+	5 ft. network cable: RJ45 (Male) to RJ45 (Male) Cat 5E cable
CBL-5FT-BMSMB+ (spare)	5 ft (1.5 m) Trigger & Reference cable: BNC (male) to SMB (Female)

CALIBRATION

CALSSG-15G-RC	Calibration Service	Click Here
---------------	---------------------	----------------------------

NOTES:

- Performance and quality attributes and conditions not expressly stated in this specification document are intended to be excluded and do not form a part of this specification document.
- Electrical specifications and performance data contained in this specification document are based on Mini-Circuit's applicable established test performance criteria and measurement instructions.
- The parts covered by this specification document are subject to Mini-Circuits standard limited warranty and terms and conditions (collectively, "Standard Terms"); Purchasers of this part are entitled to the rights and benefits contained therein. For a full statement of the Standard Terms and the exclusive rights and remedies thereunder, please visit Mini-Circuits' website at <https://www.minicircuits.com/terms/viewterm.html>

Typical Performance Data

Frequency (MHz)	Max Power Output Vs. Output Frequency (dBm)		
	0°C	+25°C	+50°C
10	4.11	4.38	4.52
50	13.92	14.08	14.13
100	15.41	15.32	15.15
250	17.41	17.33	17.14
500	16.94	16.82	16.59
1000	17.13	16.80	16.44
1500	15.82	15.96	15.90
2000	16.50	16.24	15.92
2500	16.29	16.02	15.75
3000	17.54	17.16	16.78
3500	17.35	17.07	16.76
4000	16.16	15.60	15.24
4500	14.39	14.26	14.05
5000	15.72	14.91	14.16
5500	17.30	16.88	16.30
6000	18.66	17.89	16.91
6500	18.92	17.78	16.67
7000	18.76	18.24	17.36
7500	17.23	16.87	16.21
8000	16.36	15.72	14.97
8500	16.92	16.64	16.03
9000	16.59	16.34	15.83
9500	15.18	15.04	14.61
10000	14.44	14.64	14.32
10500	16.78	16.95	16.54
11000	18.03	17.57	17.19
11500	17.51	16.82	16.19
12000	16.57	16.12	15.64
12500	17.08	16.39	15.51
13000	17.59	16.93	16.27
13500	17.27	16.71	16.01
14000	16.61	16.20	15.69
14500	16.25	15.50	14.91
15000	15.64	14.42	13.22

Frequency (MHz)	Power deviation from nominal Vs. Output Frequency (dBm)					
	-45 dBm	-40 dBm	-20 dBm	-10 dBm	0 dBm	+10 dBm
10	-0.241	-0.104	0.299	0.188	0.121	--
50	-0.053	-0.293	-0.224	0.227	0.012	-1.464
100	-0.038	0.070	-0.061	0.270	0.227	-1.711
250	-0.149	-0.116	-0.103	0.212	0.310	-0.033
500	-0.090	-0.131	-0.110	0.173	0.242	-0.101
1000	-0.072	-0.092	-0.105	0.321	0.043	-0.100
1500	0.061	-0.197	0.183	0.475	0.207	-0.302
2000	-0.046	-0.081	-0.284	0.093	0.182	0.030
2500	-0.209	-0.072	-0.346	0.204	0.058	0.222
3000	-0.134	-0.030	-0.184	0.472	0.299	0.352
3500	0.050	-0.089	0.022	-0.130	0.108	-0.097
4000	-0.084	-0.190	0.143	-0.442	-0.247	-0.529
4500	-0.294	-0.316	-0.134	0.358	0.282	0.021
5000	-0.191	-0.632	-0.042	0.303	-0.005	-0.077
5500	-0.215	-0.223	-0.217	0.148	0.225	-0.372
6000	-0.186	-0.164	-0.206	0.254	0.259	0.022
6500	0.069	-0.060	0.122	0.591	0.241	-0.309
7000	0.097	-0.040	0.112	0.490	0.355	0.249
7500	-0.177	-0.101	-0.133	0.386	0.210	0.146
8000	-0.113	-0.244	0.007	0.595	0.273	0.191
8500	0.204	0.150	-0.067	0.006	0.316	0.197
9000	-0.099	0.065	0.077	0.282	0.059	0.074
9500	0.173	0.008	0.065	0.078	0.211	-0.126
10000	-0.034	-0.263	0.246	0.008	0.293	0.168
10500	-0.150	-0.034	0.290	0.687	0.198	-0.143
11000	0.083	0.161	0.139	0.507	0.284	-0.031
11500	-0.356	-0.053	-0.079	0.248	0.093	0.071
12000	-0.175	0.192	0.090	0.429	0.424	-0.005
12500	-0.278	-0.016	0.042	0.171	0.415	0.240
13000	0.061	-0.008	0.098	0.313	0.550	-0.046
13500	-0.174	-0.033	0.098	0.280	0.504	-0.236
14000	-0.295	-0.282	-0.019	0.105	0.304	-0.488
14500	-0.043	-0.189	-0.061	0.311	0.438	0.026
15000	0.682	0.872	0.571	1.289	1.248	-5.683

Notes

- A. Performance and quality attributes and conditions not expressly stated in this specification document are intended to be excluded and do not form a part of this specification document.
- B. Electrical specifications and performance data contained in this specification document are based on Mini-Circuits' applicable established test performance criteria and measurement instructions.
- C. The parts covered by this specification document are subject to Mini-Circuits' standard limited warranty and terms and conditions (collectively, "Standard Terms"); Purchasers of this part are entitled to the rights and benefits contained therein. For a full statement of the Standard Terms and the exclusive rights and remedies thereunder, please visit Mini-Circuits' website at www.minicircuits.com/MCLStore/terms.jsp



Typical Performance Data

Power (dBm)	Power deviation from nominal										
	Vs. Output Power (dBm)										
	10 MHz	200 MHz	500 MHz	1000 MHz	2000 MHz	3000 MHz	5000 MHz	8000 MHz	10000 MHz	12000 MHz	15000 MHz
-50	0.129	-0.129	-0.143	-0.160	-0.189	-0.404	-0.425	--	--	-0.043	0.369
-48	0.080	-0.003	-0.089	-0.031	-0.094	-0.032	-0.372	0.876	0.530	0.068	0.089
-46	-0.024	-0.124	-0.198	-0.264	-0.158	-0.255	-0.382	-0.109	0.098	-0.059	-0.086
-44	-0.318	0.062	-0.094	-0.195	-0.076	-0.228	-0.144	-0.121	0.274	-0.006	-0.141
-42	0.030	-0.062	-0.108	-0.121	-0.157	-0.228	-0.268	-0.120	-0.274	0.049	0.135
-40	-0.037	-0.038	-0.113	-0.136	-0.040	-0.012	-0.250	-0.027	-0.149	0.156	-0.034
-38	-0.122	-0.092	-0.143	-0.256	-0.186	-0.191	-0.171	-0.031	0.035	-0.023	-0.015
-36	-0.425	0.049	-0.047	-0.250	0.041	-0.196	-0.345	-0.141	0.173	-0.023	-0.097
-34	0.012	-0.058	-0.132	-0.132	-0.114	-0.072	-0.490	-0.182	-0.308	-0.055	0.139
-32	0.013	0.156	0.092	0.068	0.094	0.008	-0.214	-0.127	-0.188	0.098	0.041
-30	-0.211	-0.102	-0.165	-0.168	-0.273	-0.274	-0.205	-0.234	-0.041	-0.012	-0.148
-28	0.213	-0.011	-0.047	-0.015	0.046	-0.229	-0.464	0.035	0.137	0.015	-0.172
-26	0.142	-0.141	0.000	-0.115	-0.153	-0.078	-0.595	0.059	-0.258	0.060	0.083
-24	0.475	0.089	0.068	0.049	-0.037	-0.032	-0.371	-0.059	-0.127	0.255	-0.220
-22	-0.198	-0.136	-0.162	-0.084	-0.134	-0.255	-0.243	-0.058	0.110	0.142	-0.553
-20	-0.271	-0.103	-0.133	-0.131	-0.138	-0.190	-0.104	0.057	0.369	-0.019	0.061
-18	0.147	-0.062	-0.035	-0.054	-0.269	-0.154	-0.082	0.122	-0.080	0.061	-0.358
-16	-0.289	0.001	-0.262	-0.141	-0.031	-0.089	0.014	-0.073	0.038	-0.062	-0.146
-14	0.084	0.007	-0.060	-0.095	0.009	-0.110	-0.109	0.199	0.005	0.191	-0.181
-12	0.377	0.315	0.209	0.263	0.254	0.191	0.136	0.474	0.461	0.289	0.170
-10	0.366	0.178	0.172	0.283	0.039	0.311	0.044	0.549	0.109	0.287	-0.210
-8	0.317	0.386	0.314	0.184	0.277	0.261	0.400	0.276	0.262	0.359	0.011
-6	0.090	0.329	0.413	0.237	0.327	0.424	0.419	0.431	0.448	0.578	0.265
-4	0.581	0.331	0.202	0.346	0.305	0.343	0.250	0.331	0.569	0.329	0.093
-2	0.274	0.201	0.137	0.394	0.168	0.336	-0.190	0.554	0.208	0.562	0.487
0	0.157	0.239	0.247	0.085	0.276	0.172	-0.005	0.210	0.379	0.582	0.599
2	0.176	-0.006	-0.035	-0.101	-0.185	0.088	-0.215	0.064	0.229	0.065	-0.119
4	0.134	-0.111	0.020	0.071	0.040	0.012	-0.051	0.027	0.366	0.186	0.118
6	--	-0.111	-0.223	-0.244	-0.147	-0.022	-0.195	0.033	0.553	0.134	-0.056
8	--	-0.088	-0.160	-0.245	0.127	0.202	0.007	0.278	0.039	0.116	-0.120
10	--	-0.008	-0.137	-0.076	0.035	0.346	-0.173	0.231	0.151	-0.115	-0.331
12	--	-0.164	-0.002	-0.058	-0.085	0.324	-0.033	0.280	0.317	0.189	0.014
14	--	-0.076	-0.241	-0.329	0.095	0.122	-0.351	0.177	0.046	0.137	-0.293
15	--	-0.157	-0.235	-0.019	-0.028	0.051	-0.212	0.083	0.076	0.073	--

Notes

- A. Performance and quality attributes and conditions not expressly stated in this specification document are intended to be excluded and do not form a part of this specification document.
- B. Electrical specifications and performance data contained in this specification document are based on Mini-Circuits' applicable established test performance criteria and measurement instructions.
- C. The parts covered by this specification document are subject to Mini-Circuits' standard limited warranty and terms and conditions (collectively, "Standard Terms"); Purchasers of this part are entitled to the rights and benefits contained therein. For a full statement of the Standard Terms and the exclusive rights and remedies thereunder, please visit Mini-Circuits' website at www.minicircuits.com/MCLStore/terms.jsp



USB Synthesized Signal Generator

SSG-15G-RC

Typical Performance Data

Frequency (MHz)	Harmonics Levels Vs. Output Frequency							
	-40dBm		-20dBm		0dBm		+10dBm	
	F2	F3	F2	F3	F2	F3	F2	F3
10	-72.39	-10.14	-42.94	-4.30	-6.26	-4.08	-6.21	-4.13
50	-65.84	-10.40	-54.33	-9.83	-16.98	-9.93	-17.08	-9.96
100	-58.09	-9.87	-55.50	-9.68	-32.46	-10.56	-32.50	-10.59
250	-42.10	-9.75	-42.67	-9.43	-31.05	-9.55	-31.18	-9.93
500	-28.36	-9.05	-27.28	-7.95	-26.67	-7.69	-26.93	-8.09
1000	-16.62	-10.48	-15.24	-4.86	-14.91	-5.22	-14.97	-5.13
1500	-11.27	-24.48	-6.52	-31.13	-6.14	-29.78	-5.98	-29.48
2000	-16.07	-14.79	-16.41	-44.55	-15.12	-44.64	-15.29	-45.10
2500	-23.01	-21.65	-38.79	-61.29	-37.57	-63.98	-37.51	-63.80
3000	-22.56	-24.96	-49.03	-58.90	-48.70	-64.03	-50.48	-78.78
3500	-28.61	-25.89	-55.76	-61.59	-58.52	-65.91	-57.77	-65.49
4000	-28.35	-27.80	-76.86	-68.65	-79.26	-71.70	-77.22	-71.74
4500	-30.18	-27.10	-62.77	-76.96	-63.40	-77.72	-33.17	-22.86
5000	-23.10	-31.12	-55.81	-55.72	-21.86	-23.46	-21.87	-24.51
5500	-27.67	-46.01	-25.99	-49.26	-25.42	-52.37	-24.85	-52.75
6000	-22.27	-35.20	-23.21	-38.21	-24.28	-45.96	-23.90	-46.23
6500	-16.10	-38.39	-15.64	-40.99	-28.04	-20.53	-27.56	-21.14
7000	-12.34	-51.65	-13.22	-54.63	-22.26	-25.10	-22.84	-25.56
7500	-19.72	-56.82	-21.04	-69.19	-27.56	-31.60	-28.32	-32.15
8000	-28.17	-72.97	-31.48	-66.08	-34.99	-35.40	-30.50	-44.26
8500	-43.86	-84.20	-45.89	-93.10	-26.52	-36.59	-25.47	-48.03
8750	-34.68	-81.04	-36.58	-91.59	-25.38	-39.07	-26.38	-49.62
9000	-28.03	-74.11	-29.95	-92.27	-25.46	-38.53	-26.19	-49.60
9250	-26.29	-72.58	-29.84	-91.80	-19.32	-38.76	-19.91	-39.04
9500	-30.02	-78.41	-32.71	-96.22	-13.87	-37.28	-15.22	-47.49
9750	-48.22	-89.70	-51.81	-94.33	-15.72	-41.99	-16.32	-48.40
10000	-44.84	-84.14	-47.84	-94.85	-17.06	-43.79	-18.73	-50.58
10250	-42.45	-92.26	-48.24	-94.54	-48.40	-90.57	-19.97	-48.19
10500	-44.22	-86.78	-50.16	-89.86	-21.99	-36.16	-23.39	-47.69
10750	-58.92	-85.70	-59.69	-90.00	-28.08	-33.54	-28.57	-33.65
11000	-59.23	-84.91	-68.93	-86.95	-56.02	-87.48	-31.73	-32.38
11250	-59.58	-86.20	-72.19	-88.92	-34.92	-32.57	-34.40	-32.35
11500	-54.10	-87.28	-57.60	-70.78	-42.67	-30.78	-42.77	-31.55
11750	-62.30	-85.71	-64.99	-86.66	-42.23	-40.89	-42.18	-40.02
12000	-78.29	-81.26	-56.79	-83.74	-41.04	-47.85	-40.77	-45.50
12250	-74.35	-79.45	-59.25	-77.72	-39.37	-42.36	-38.87	-40.59
12500	-68.89	-78.87	-62.72	-80.61	-39.32	-40.80	-39.12	-40.60
12750	-73.06	-75.40	-89.68	-86.00	-38.22	-40.55	-37.79	-39.62
13000	-72.96	-72.24	-60.03	-74.10	-38.50	-32.05	-37.97	-32.30
13250	-77.36	-67.68	-66.99	-74.86	-39.36	-31.39	-39.10	-32.17
13500	-85.46	-72.32	-93.56	-85.08	-42.15	-35.67	-41.75	-36.59
13750	-74.84	-80.45	-70.24	-78.76	-41.95	-34.44	-41.59	-33.76
14000	-84.37	-75.61	-66.83	-57.74	-72.64	-81.91	-77.37	-73.76
14250	-72.66	-82.05	-74.68	-63.48	-81.34	-84.37	-86.75	-74.55
14500	-73.06	-78.99	-71.25	-75.48	-92.90	-83.16	-64.92	-51.86
14750	-81.33	-72.82	-80.88	-78.98	-51.06	-42.10	-62.66	-53.06
15000	-90.76	-69.31	-82.58	-76.52	-52.92	-44.94	-63.35	-54.54

Notes

- A. Performance and quality attributes and conditions not expressly stated in this specification document are intended to be excluded and do not form a part of this specification document.
- B. Electrical specifications and performance data contained in this specification document are based on Mini-Circuits' applicable established test performance criteria and measurement instructions.
- C. The parts covered by this specification document are subject to Mini-Circuits' standard limited warranty and terms and conditions (collectively, "Standard Terms"); Purchasers of this part are entitled to the rights and benefits contained therein. For a full statement of the Standard Terms and the exclusive rights and remedies thereunder, please visit Mini-Circuits' website at www.minicircuits.com/MCLStore/terms.jsp



Typical Performance Data

Frequency (MHz)	Phase Noise vs. Output frequency at selected offsets (dBc/Hz)				
	+25°C				
	100Hz	1kHz	10kHz	100kHz	1MHz
10	-132.00	-137.00	-140.80	-146.00	-147.00
50	-118.41	-133.52	-141.15	-143.09	-156.76
100	-113.61	-129.79	-137.23	-137.12	-158.85
200	-107.14	-124.77	-131.58	-131.31	-155.86
400	-100.37	-118.25	-125.35	-125.28	-151.17
800	-97.34	-111.78	-118.17	-118.48	-144.66
1600	-95.43	-106.11	-112.95	-112.81	-139.08
2000	-90.16	-104.50	-110.88	-110.93	-137.67
3200	-85.60	-100.16	-106.56	-106.27	-130.39
4000	-82.97	-98.27	-105.24	-105.32	-132.04
5000	-82.58	-96.09	-102.57	-102.84	-129.84
6000	-79.69	-94.33	-101.02	-100.89	-126.22
6400	-76.64	-94.14	-100.77	-100.45	-124.41
7000	-76.54	-93.49	-100.06	-99.70	-124.92
8000	-70.50	-90.01	-98.47	-98.97	-125.67
9000	-71.69	-90.53	-97.42	-97.91	-124.87
10000	-70.93	-92.88	-96.71	-96.93	-124.04
11000	-68.24	-91.06	-95.60	-95.82	-122.60
12000	-68.51	-90.75	-95.04	-94.88	-120.25
12800	-67.71	-89.92	-94.65	-94.43	-118.61
14000	-69.35	-89.24	-93.63	-93.40	-118.72
14500	-67.96	-91.61	-93.34	-93.12	-117.75
15000	-68.74	-88.12	-93.21	-92.84	-116.80

Notes

- A. Performance and quality attributes and conditions not expressly stated in this specification document are intended to be excluded and do not form a part of this specification document.
- B. Electrical specifications and performance data contained in this specification document are based on Mini-Circuits' applicable established test performance criteria and measurement instructions.
- C. The parts covered by this specification document are subject to Mini-Circuits' standard limited warranty and terms and conditions (collectively, "Standard Terms"); Purchasers of this part are entitled to the rights and benefits contained therein. For a full statement of the Standard Terms and the exclusive rights and remedies thereunder, please visit Mini-Circuits' website at www.minicircuits.com/MCLStore/terms.jsp



USB Synthesized Signal Generator

SSG-15G-RC

Typical Performance Data

Frequency Offset (kHz)	Phase Noise (dBc/Hz)						
	vs Offset frequency at selected output frequencies						
	@100MHz	@1000MHz	@4000MHz	@7000MHz	@10000MH	@12000MH	@15000MH
0.10	-114.17	-93.00	-83.66	-82.23	-71.23	-70.02	-67.40
0.12	-114.26	-95.08	-85.64	-77.26	-69.58	-72.07	-70.55
0.14	-119.32	-95.57	-84.03	-79.82	-74.55	-71.50	-73.01
0.17	-120.72	-97.94	-86.30	-81.55	-73.90	-74.70	-71.97
0.20	-124.22	-99.50	-86.22	-81.86	-72.58	-72.71	-71.42
0.24	-120.03	-102.71	-89.25	-85.99	-73.15	-72.78	-73.94
0.29	-122.89	-104.04	-92.61	-86.55	-73.49	-72.22	-73.60
0.35	-124.45	-103.29	-95.21	-88.23	-70.70	-72.64	-69.83
0.42	-125.81	-106.95	-94.49	-87.93	-73.04	-74.54	-75.13
0.50	-125.38	-106.42	-96.33	-91.96	-74.17	-74.08	-75.70
0.60	-126.74	-108.72	-96.66	-89.99	-76.23	-74.13	-74.41
0.71	-131.70	-108.15	-99.81	-91.28	-78.17	-76.26	-76.44
0.84	-128.63	-108.24	-98.68	-92.94	-80.33	-79.73	-79.62
1.00	-130.40	-110.01	-98.87	-93.38	-83.39	-81.85	-79.91
1.20	-130.49	-110.58	-99.03	-95.51	-83.95	-83.50	-82.60
1.43	-133.16	-111.03	-99.89	-97.56	-87.20	-86.94	-86.10
1.71	-133.06	-111.70	-101.58	-95.57	-88.94	-88.37	-86.48
2.04	-132.64	-113.44	-101.55	-97.09	-90.20	-89.22	-88.75
2.44	-134.82	-114.71	-102.31	-96.77	-92.23	-91.46	-89.18
2.92	-136.19	-114.54	-102.59	-98.21	-94.05	-92.30	-90.58
3.49	-135.42	-115.56	-103.85	-98.50	-94.42	-92.82	-90.87
4.17	-137.20	-115.94	-104.45	-98.52	-94.82	-93.77	-92.33
4.99	-135.91	-116.01	-104.39	-99.11	-95.62	-94.14	-91.97
5.96	-136.61	-116.66	-105.14	-100.16	-96.16	-94.80	-92.77
7.12	-137.21	-115.98	-105.16	-100.12	-97.14	-95.19	-92.67
8.37	-137.79	-117.51	-105.26	-100.54	-96.66	-94.60	-93.70
10.00	-137.10	-116.28	-105.04	-100.46	-97.04	-94.99	-93.51
11.95	-137.85	-117.36	-105.12	-100.44	-97.51	-94.89	-93.02
14.29	-137.13	-116.41	-105.08	-100.21	-96.64	-95.31	-93.01
17.08	-137.71	-116.49	-105.31	-100.20	-96.50	-95.07	-93.13
20.42	-137.22	-116.61	-105.13	-100.11	-96.56	-94.98	-93.03
24.41	-136.58	-116.52	-104.82	-100.03	-96.36	-94.98	-93.16
29.18	-136.50	-115.83	-104.50	-99.80	-96.44	-94.78	-92.99
34.88	-136.59	-115.99	-104.20	-99.57	-95.84	-94.59	-92.45
41.70	-136.36	-115.56	-104.23	-99.04	-95.69	-94.21	-92.50
49.85	-135.83	-115.38	-104.05	-98.99	-95.37	-93.94	-92.15
59.59	-135.87	-115.08	-103.82	-98.88	-95.27	-93.98	-92.26
71.24	-136.43	-115.70	-104.32	-99.44	-95.77	-94.14	-91.74
83.65	-136.82	-116.02	-104.95	-99.61	-96.38	-94.38	-92.71
100.00	-137.64	-117.08	-105.55	-100.08	-97.23	-95.13	-93.24
119.54	-138.58	-118.15	-106.68	-100.95	-98.71	-96.26	-94.08
142.90	-140.72	-120.53	-109.21	-102.87	-100.62	-97.78	-95.23
170.83	-143.26	-123.26	-111.96	-105.11	-103.41	-100.20	-97.56
204.21	-146.04	-126.02	-114.71	-107.46	-106.26	-102.60	-99.89
244.12	-148.14	-128.53	-117.08	-109.65	-108.59	-104.87	-101.78
291.82	-150.27	-130.67	-119.30	-111.65	-110.75	-106.86	-103.64
348.85	-152.21	-132.71	-121.31	-113.67	-112.88	-108.93	-105.61
417.02	-154.03	-134.61	-123.21	-115.56	-114.87	-110.86	-107.47
498.51	-155.50	-136.62	-125.16	-117.69	-116.71	-112.83	-109.50
595.93	-157.36	-138.42	-126.98	-119.58	-118.71	-114.88	-111.46
712.38	-158.49	-140.12	-128.77	-121.60	-120.62	-116.70	-113.36
851.59	-160.13	-141.89	-130.59	-123.32	-122.47	-118.63	-115.25
1000.00	-158.85	-141.31	-130.27	-122.83	-121.42	-118.47	-114.59

Notes

- A. Performance and quality attributes and conditions not expressly stated in this specification document are intended to be excluded and do not form a part of this specification document.
- B. Electrical specifications and performance data contained in this specification document are based on Mini-Circuits applicable established test performance criteria and measurement instructions.
- C. The parts covered by this specification document are subject to Mini-Circuits standard limited warranty and terms and conditions (collectively, "Standard Terms"); Purchasers of this part are entitled to the rights and benefits contained therein. For a full statement of the Standard Terms and the exclusive rights and remedies thereunder, please visit Mini-Circuits' website at www.minicircuits.com/MCLStore/terms.jsp



Typical Performance Data

Frequency (MHz)	Spurious @ ±100kHz to 50 MHz offset vs. output frequency, @ PWR=+5dBm		
	0°C	+25°C	+50°C
100	-85.12	-80.69	-84.65
250	-85.59	-95.72	-88.39
500	-85.53	-88.58	-81.88
1000	-83.05	-81.54	-81.96
1500	-79.05	-75.34	-75.47
2000	-80.11	-78.75	-77.99
2500	-81.29	-70.61	-77.68
3000	-76.79	-76.59	-76.90
3500	-85.64	-82.00	-85.53
4000	-75.37	-74.59	-75.46
4500	-76.97	-76.47	-77.10
5000	-76.93	-79.72	-80.84
5500	-79.64	-78.83	-76.27
6000	-82.72	-82.52	-83.24
6500	-74.73	-71.47	-70.33
7000	-72.05	-72.22	-72.55
7500	-71.57	-71.03	-71.46
8000	-68.56	-68.07	-68.46
8500	-68.35	-69.06	-69.78
9000	-72.21	-71.73	-72.46
9500	-70.77	-70.62	-71.17
10000	-72.47	-72.77	-73.89
10500	-71.94	-72.17	-72.97
11000	-72.90	-73.56	-74.38
11500	-72.83	-73.06	-74.22
12000	-71.89	-72.13	-73.62
12500	-71.56	-71.50	-72.12
13000	-70.28	-70.17	-71.48
13500	-72.22	-72.28	-73.74
14000	-71.91	-71.58	-72.61
14500	-73.49	-73.19	-74.46
15000	-73.55	-73.03	-73.94

Notes

- A. Performance and quality attributes and conditions not expressly stated in this specification document are intended to be excluded and do not form a part of this specification document.
- B. Electrical specifications and performance data contained in this specification document are based on Mini-Circuits' applicable established test performance criteria and measurement instructions.
- C. The parts covered by this specification document are subject to Mini-Circuits' standard limited warranty and terms and conditions (collectively, "Standard Terms"); Purchasers of this part are entitled to the rights and benefits contained therein. For a full statement of the Standard Terms and the exclusive rights and remedies thereunder, please visit Mini-Circuits' website at www.minicircuits.com/MCLStore/terms.jsp



Typical Performance Data

Max Power Output Vs Output Frequency

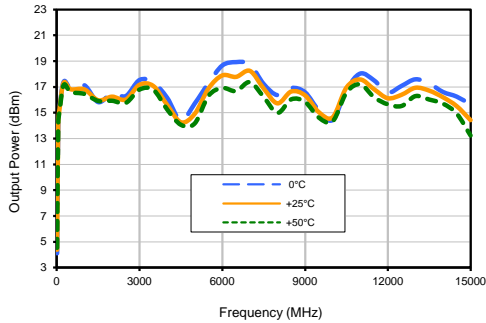

Power Deviation from Nominal Vs. Output Frequency

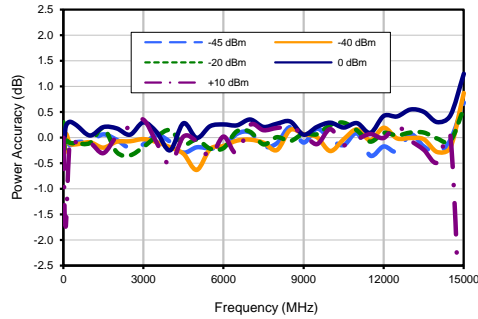

Power Deviation from Nominal Vs. Output Power

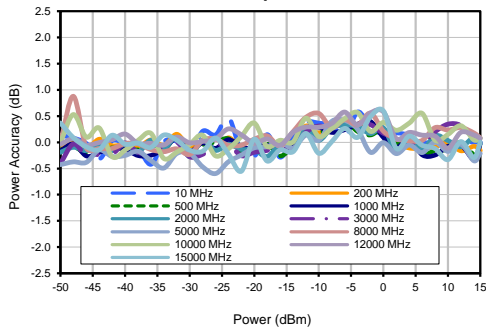

Spurious @ ±100kHz to 50MHz offset vs Output Frequency, @PWR=+5 dBm

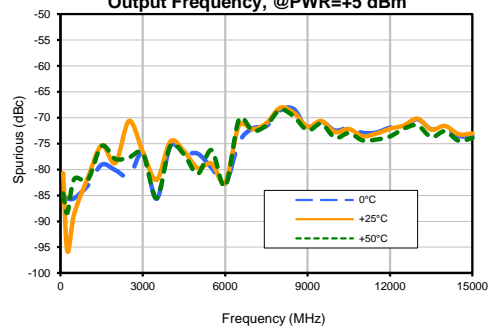

Second Harmonic Vs. Output Frequency

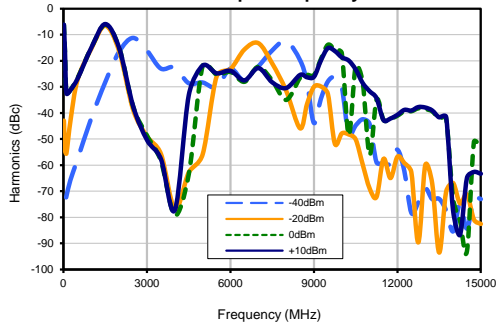

Third Harmonic Vs. Output Frequency

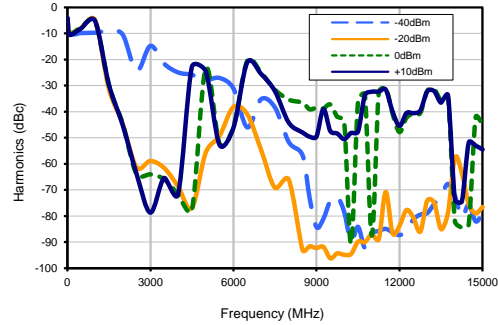

Notes

- A. Performance and quality attributes and conditions not expressly stated in this specification document are intended to be excluded and do not form a part of this specification document.
- B. Electrical specifications and performance data contained in this specification document are based on Mini-Circuits' applicable established test performance criteria and measurement instructions.
- C. The parts covered by this specification document are subject to Mini-Circuits' standard limited warranty and terms and conditions (collectively, "Standard Terms"); Purchasers of this part are entitled to the rights and benefits contained therein. For a full statement of the Standard Terms and the exclusive rights and remedies thereunder, please visit Mini-Circuits' website at www.minicircuits.com/MCLStore/terms.jsp

Typical Performance Data

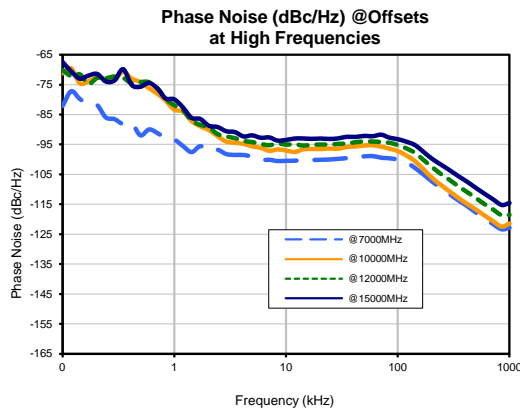
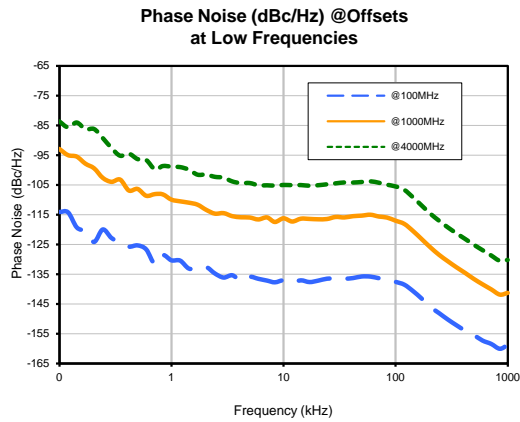
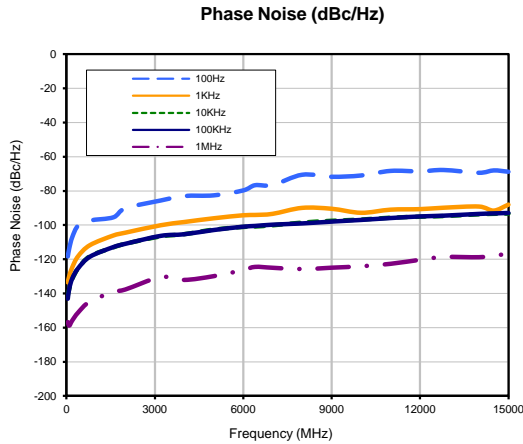

Notes

- A. Performance and quality attributes and conditions not expressly stated in this specification document are intended to be excluded and do not form a part of this specification document.
- B. Electrical specifications and performance data contained in this specification document are based on Mini-Circuits' applicable established test performance criteria and measurement instructions.
- C. The parts covered by this specification document are subject to Mini-Circuits' standard limited warranty and terms and conditions (collectively, "Standard Terms"); Purchasers of this part are entitled to the rights and benefits contained therein. For a full statement of the Standard Terms and the exclusive rights and remedies thereunder, please visit Mini-Circuits' website at www.minicircuits.com/MCLStore/terms.jsp

Case Style

SL

Outline Dimensions

SL2686

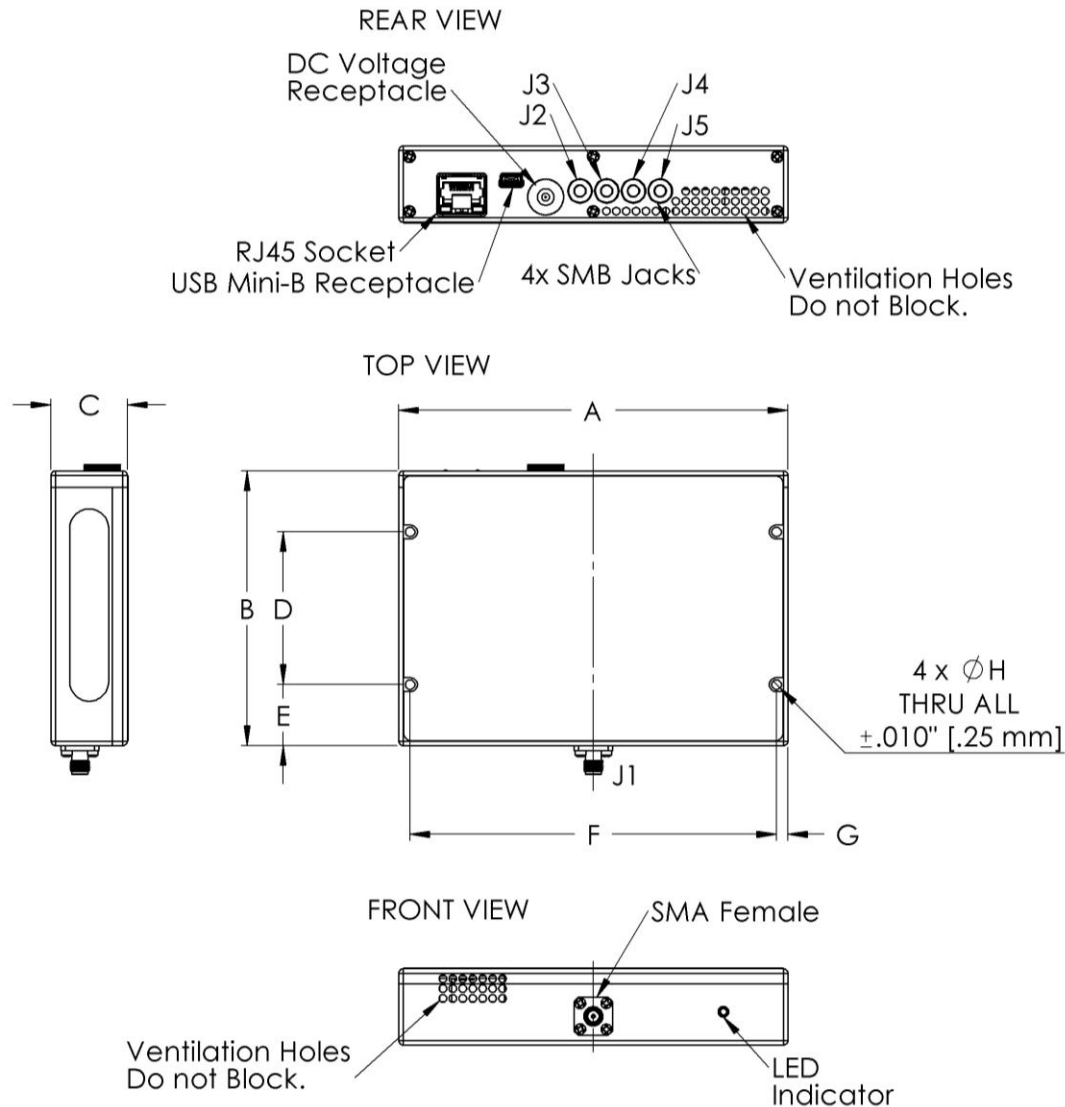

CASE#	A	B	C	D	E	F	G	H	Wt. Grams
SL2686	5.10 (129.5)	3.60 (91.4)	1.00 (25.4)	2.000 (50.80)	.800 (20.32)	4.800 (121.92)	.150 (3.81)	.125 (3.18)	600

Dimensions are in inches (mm). Tolerances: 2PL. +/- .03; 3PL. +/- .015

Notes:

1. Case material: Aluminum alloy.
2. Case finish: Nickel Plate.

Mini-Circuits[®]

INTERNET <http://www.minicircuits.com>

P.O. Box 350166, Brooklyn, New York 11235-0003 (718) 934-4500 Fax (718) 332-4661

Distribution Centers NORTH AMERICA 800-654-7949 • 417-335-5935 • Fax 417-335-5945 • EUROPE 44-1252-832600 • Fax 44-1252-837010

Mini-Circuits ISO 9001 & ISO 14001 Certified



Environmental Specifications **ENV55**

All Mini-Circuits products are manufactured under exacting quality assurance and control standards, and are capable of meeting published specifications after being subjected to any or all of the following physical and environmental test.

Specification	Test/Inspection Condition	Reference/Spec
Operating Temperature	-0° to 50° C Ambient Environment	Individual Model Data Sheet
Storage Temperature	-20° to 60° C Ambient Environment	Individual Model Data Sheet
Operating and Storage Humidity	5% to 85% RH (non-condensing)	Ambient
Bench Handling Test	Bench Top Tip 45° & Drop	MIL-PRF-28800F
Transit Drop Test	Free Fall Drop, 20 cm (7.9 inches)	MIL-PRF-28800F Class 3