



COAXIAL

Adapter

SMPM-SF50-27+

50Ω DC to 27 GHz SMP-Male to SMA-Female

KEY FEATURES

- Wideband, DC to 27 GHz
- Low Insertion Loss, 0.01 dB Typ.
- Excellent VSWR, 1.05:1 Typ.



Generic photo used for illustration purposes only

PRODUCT OVERVIEW

Mini-Circuits' SMPM-SF50-27+ is a coaxial full detent SMP Male to SMA Female adapter supporting a wide range of applications from DC to 27 GHz. This model provides excellent VSWR and low insertion loss versus frequency. The SMPM-SF50-27+ features passivated stainless-steel construction and measures only 0.71" in length.

ELECTRICAL SPECIFICATIONS AT +25°C

Parameter	Condition (GHz)	Min.	Typ.	Max.	Units
Frequency Range		DC		27	GHz
Insertion Loss	DC-12	—	0.08	0.21	dB
	12-18	—	0.10	0.25	
	18-27	—	0.12	0.31	
VSWR	DC-12	—	1.03	1.15	:1
	12-18	—	1.05	1.15	
	18-27	—	1.08	1.15	

ABSOLUTE MAXIMUM RATINGS¹

Parameter	Ratings
Operating Case Temperature	-55 °C to +105 °C
Storage Temperature	-65 °C to +125 °C

1. Permanent damage may occur if any of these limits are exceeded.



COAXIAL

Adapter

SMPM-SF50-27+

Mini-Circuits

50Ω DC to 27 GHz SMP-Male to SMA-Female

TYPICAL PERFORMANCE GRAPHS

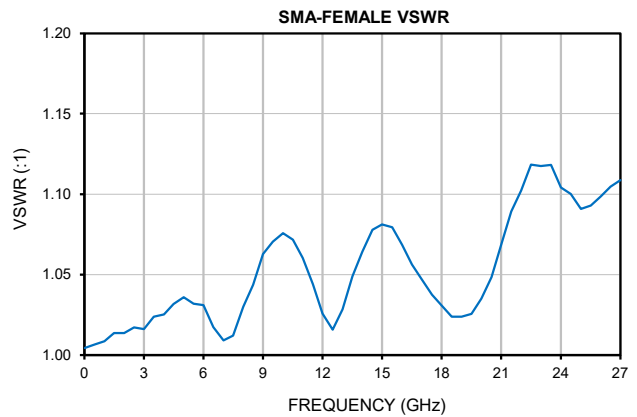
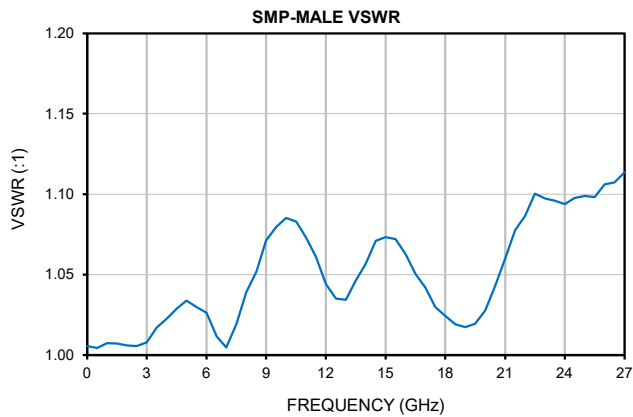
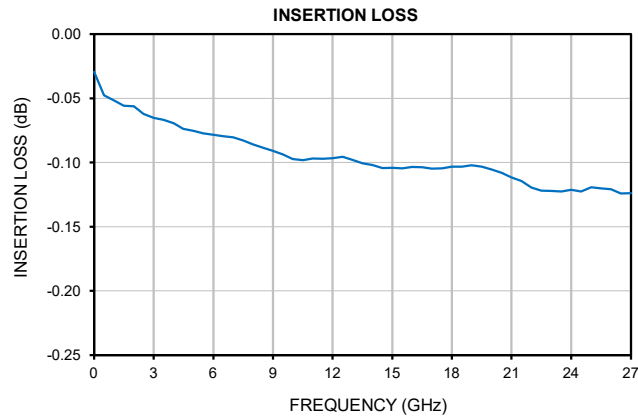



COAXIAL

Adapter

SMPM-SF50-27+

50Ω DC to 27 GHz SMP-Male to SMA-Female

CONNECTOR SPECIFICATIONS

Description	Connector 1	Connector 2
Connector Type	Full Detent SMP Male	SMA Female
Orientation	Straight	Straight
Connector Standard	MIL-STD-348B	MIL-STD-348B

CASE STYLE DRAWING

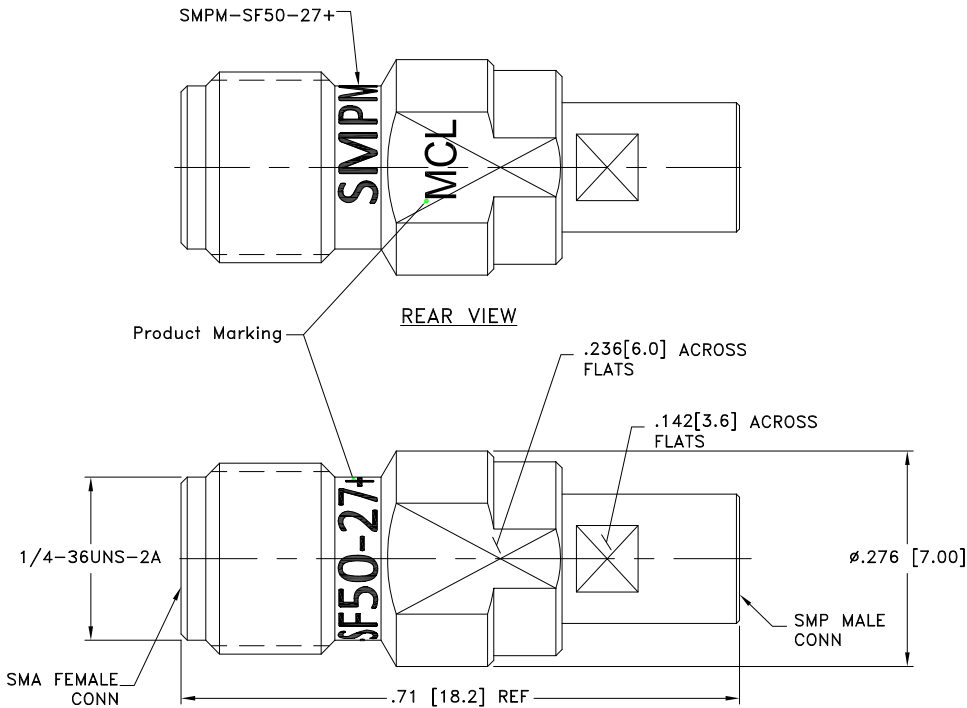

Weight: 2.25 grams
 Dimensions are in inches [mm]. Tolerances: 2 Pl. $\pm .030$; 3 Pl. $\pm .015$ Inches

PRODUCT MARKING*: SMPM-SF50-27+

*Marking may contain other features or characters for internal lot control.



COAXIAL

Adapter

SMPM-SF50-27+

50Ω DC to 27 GHz SMP-Male to SMA-Female

ADDITIONAL INFORMATION IS AVAILABLE ON OUR DASHBOARD [CLICK HERE](#)

Performance Data & Graphs	<p>Data</p> <p>Graphs</p> <p>S-Parameter (S2P Files) Data Set (.zip file)</p>
Case Style	DJ3488-4
RoHs Status	Compliant
Environmental Ratings	ENV70T3

NOTES

- A. Performance and quality attributes and conditions not expressly stated in this specification document are intended to be excluded and do not form a part of this specification document.
- B. Electrical specifications and performance data contained in this specification document are based on Mini-Circuit's applicable established test performance criteria and measurement instructions.
- C. The parts covered by this specification document are subject to Mini-Circuits standard limited warranty and terms and conditions (collectively, "Standard Terms"); Purchasers of this part are entitled to the rights and benefits contained therein. For a full statement of the standard terms and the exclusive rights and remedies thereunder, please visit Mini-Circuits' website at www.minicircuits.com/terms/viewterm.html



Typical Performance Data

FREQ.	INSERTION LOSS	SMP-MALE VSWR	SMA-FEMALE VSWR
(GHz)	(dB)	(:1)	(:1)
0.01	0.03	1.01	1.00
0.5	0.05	1.00	1.01
1.0	0.05	1.01	1.01
1.5	0.06	1.01	1.01
2.0	0.06	1.01	1.01
2.5	0.06	1.01	1.02
3.0	0.07	1.01	1.02
3.5	0.07	1.02	1.02
4.0	0.07	1.02	1.03
4.5	0.07	1.03	1.03
5.0	0.08	1.03	1.04
5.5	0.08	1.03	1.03
6.0	0.08	1.03	1.03
6.5	0.08	1.01	1.02
7.0	0.08	1.00	1.01
7.5	0.08	1.02	1.01
8.0	0.09	1.04	1.03
8.5	0.09	1.05	1.04
9.0	0.09	1.07	1.06
9.5	0.09	1.08	1.07
10.0	0.10	1.09	1.08
10.5	0.10	1.08	1.07
11.0	0.10	1.07	1.06
11.5	0.10	1.06	1.04
12.0	0.10	1.04	1.03
12.5	0.10	1.03	1.02
13.0	0.10	1.03	1.03
13.5	0.10	1.05	1.05
14.0	0.10	1.06	1.06
14.5	0.10	1.07	1.08
15.0	0.10	1.07	1.08
15.5	0.10	1.07	1.08
16.0	0.10	1.06	1.07
16.5	0.10	1.05	1.06
17.0	0.10	1.04	1.05
17.5	0.10	1.03	1.04
18.0	0.10	1.02	1.03
18.5	0.10	1.02	1.02
19.0	0.10	1.02	1.02
19.5	0.10	1.02	1.03
20.0	0.11	1.03	1.04
20.5	0.11	1.04	1.05
21.0	0.11	1.06	1.07
21.5	0.11	1.08	1.09
22.0	0.12	1.09	1.10
22.5	0.12	1.10	1.12
23.0	0.12	1.10	1.12
23.5	0.12	1.10	1.12
24.0	0.12	1.09	1.10
24.5	0.12	1.10	1.10
25.0	0.12	1.10	1.09
25.5	0.12	1.10	1.09
26.0	0.12	1.11	1.10
26.5	0.12	1.11	1.10
27.0	0.12	1.11	1.11



Typical Performance Curves

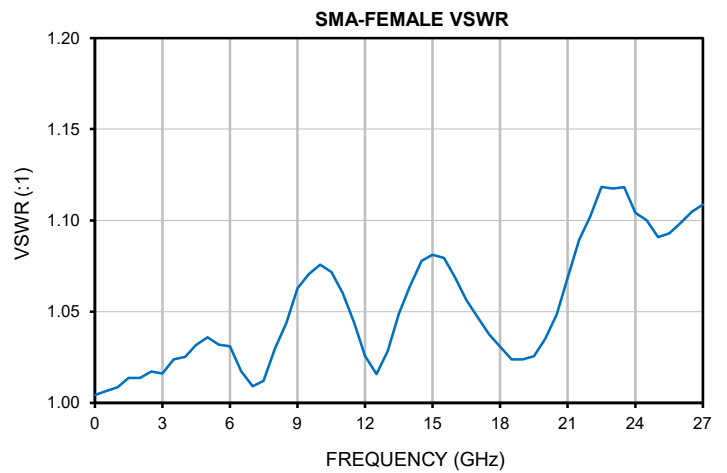
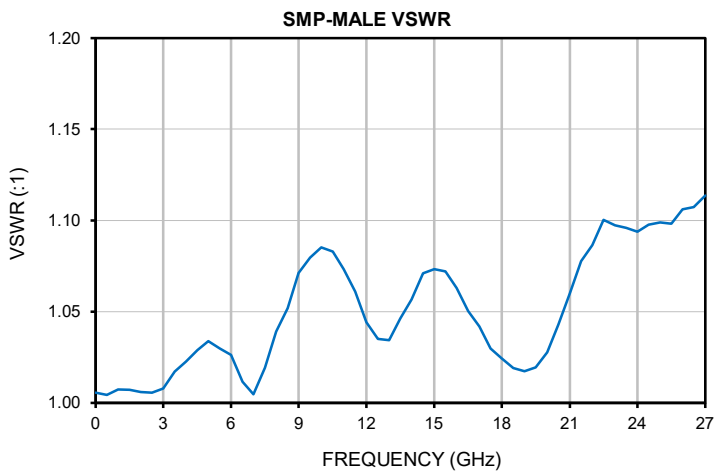
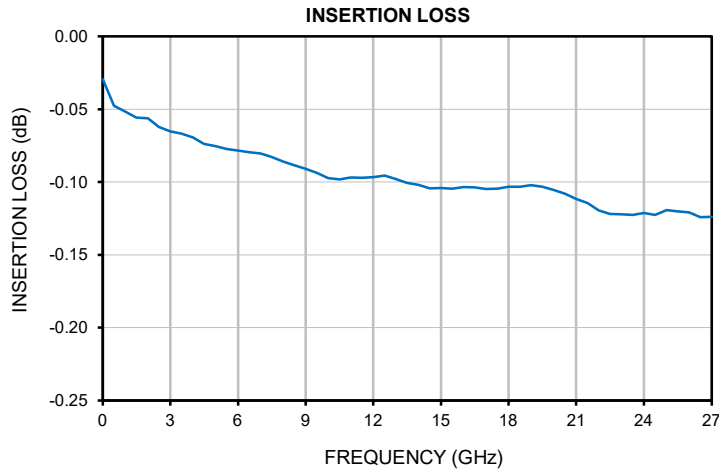

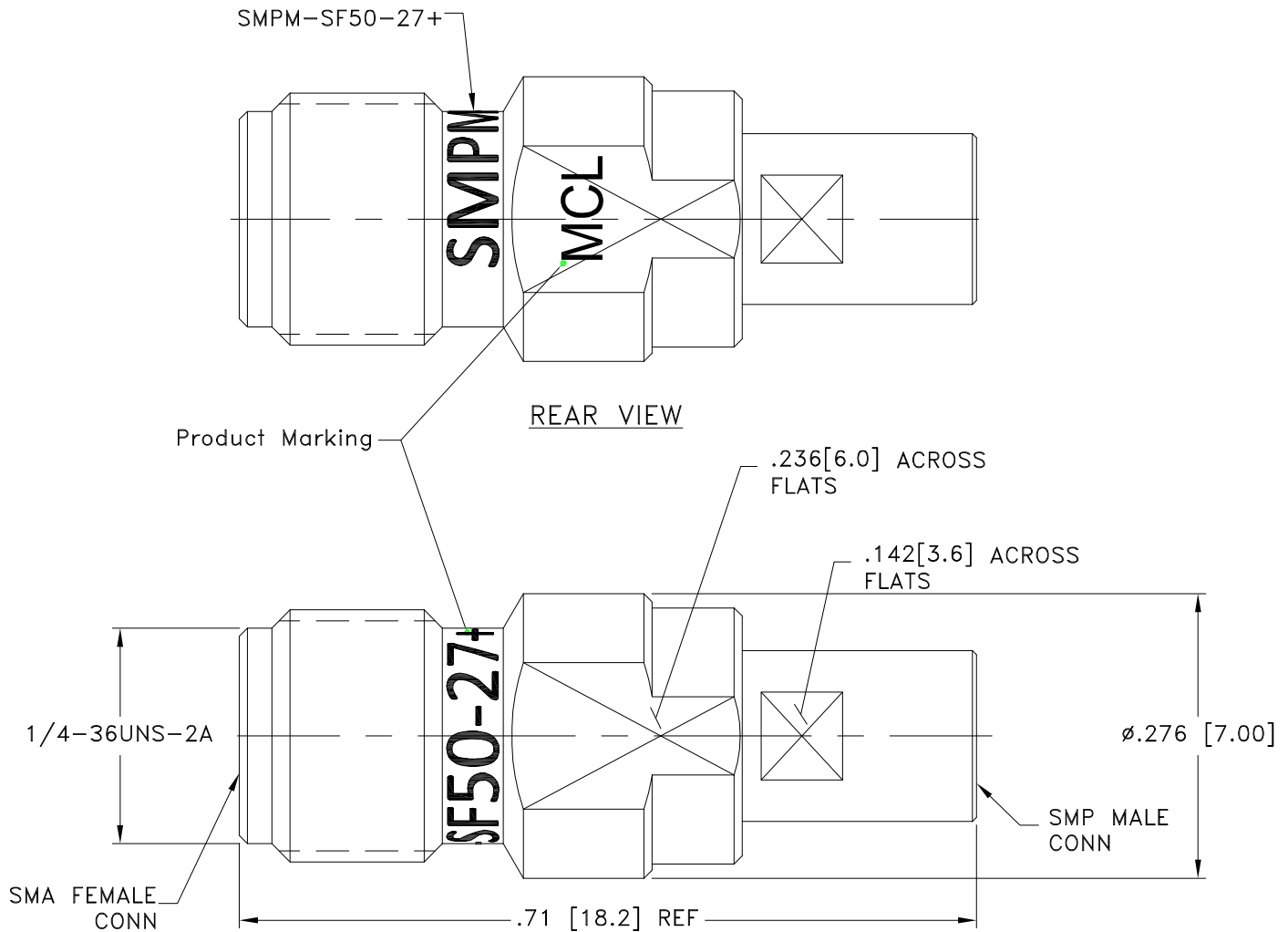

Weight: 2.25 grams

Dimensions are in inches [mm]. Tolerances: 2 Pl. $\pm .030$; 3 Pl. $\pm .015$ Inches

Notes:

Case material: Stainless steel.
Case Finish: Passivated.

Mini-Circuits®
ISO 9001 ISO 14001 CERTIFIED

ALL NEW
minicircuits.com

P.O. Box 350166, Brooklyn, New York 11235-0003 (718) 934-4500 Fax (718) 332-4661 For detailed performance specs & shopping online see Mini-Circuits web site



The Design Engineers Search Engine Provides ACTUAL Data Instantly From MINI-CIRCUITS At: www.minicircuits.com

RF/IF MICROWAVE COMPONENTS

All Mini-Circuits products are manufactured under exacting quality assurance and control standards, and are capable of meeting published specifications after being subjected to any or all of the following physical and environmental test.

Specification	Test/Inspection Condition	Reference/Spec
Operating Temperature	-55°C to 105°C Ambient Environment	Individual Model Data Sheet
Storage Temperature	-65°C to 125° C Ambient Environment	Individual Model Data Sheet
Thermal Shock	-65° to 125°C, 5 cycles	MIL-STD-202, Method 107
Durability (Mating) - SMA	≥ 500 cycles	
Durability (mating) - SMP	Full Detent ≥ 100 cycles (Engagement Force ≤ 15 lbs, Disengagement Force ≥ 5 lbs)	---
Durability (mating) - SMP	Limited Detent ≥ 500 cycles (Engagement Force ≤ 10 lbs, Disengagement Force ≥ 2 lbs)	---
Durability (mating) - SMP	Smooth Bore Catchers Mitt ≥ 1000 cycles (Engagement Force ≤ 2 lbs, Disengagement Force ≥ 0.5 lbs)	---