



CERAMIC

# Power Splitter/Combiner

# SCW-2-332+

Mini-Circuits

2 Way-0° 50Ω 2400 to 3300 MHz

## THE BIG DEAL

- Isolation resistor, external 100 ohms
- Small size, (1.6x0.8mm)
- ESD non-sensitive
- Temperature stable LTCC technology
- Wrap around terminations for excellent solderability
- Low cost



Generic photo used for illustration purposes only  
CASE STYLE: JC0603C

### +RoHS Compliant

The +Suffix identifies RoHS Compliance. See our web site for RoHS Compliance methodologies and qualifications

## APPLICATIONS

- Cellular Communication
- WLAN

## PRODUCT OVERVIEW

Mini-Circuits new LTCC 0° Power Splitter SCW-2-332+, offers industry leading combination of operating performance and size. The outstanding phase and amplitude unbalance make this component a versatile building block for use in a variety of systems and sub-system designs.

## KEY FEATURES

Feature	Advantages
Small Size	Offered in the package size, SCW-2-332+ offers an industry leading combination of size, power handling, and frequency. The small footprint allows for reduced parasitics in systems with improved performance and simplified layout.
Wrap-Around Terminations	Provides excellent solderability and easy visual inspection.
LTCC Construction	Provides repeatable performance in the rugged, ceramic package well suited for tough environments such as high humidity and temperature extremes.





CERAMIC

# Power Splitter/Combiner

# SCW-2-332+

Mini-Circuits

### ELECTRICAL SPECIFICATIONS AT 25°C

Parameter	Frequency (MHz)	Min.	Typ.	Max.	Unit
Frequency Range		2400		3300	MHz
Insertion Loss, above 3.0 dB	2400 - 3300	–	0.7	1	dB
Isolation	2400 - 3300	12	15	–	dB
Phase Unbalance	2400 - 3300	–	2	5	Degree
Amplitude Unbalance	2400 - 3300	–	0.2	0.5	dB
Return Loss (Input)	2400 - 3300	–	11	–	dB
Return Loss (Output)	2400 - 3300	–	16	–	dB

### MAXIMUM RATINGS

Parameter	Ratings
Operating Temperature	-55°C to 125°C
Storage Temperature	-55°C to 125°C
Power Input (as a splitter)	2W* max.

\* Power input as combiner is limited by rating of external resistor 100Ω resistor. Permanent damage may occur if any of these limits are exceeded.

### ELECTRICAL SCHEMATIC

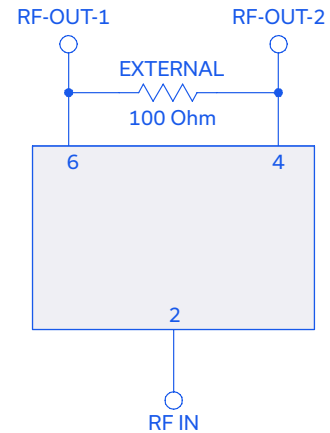



CERAMIC

# Power Splitter/Combiner

**SCW-2-332+**

Mini-Circuits

## PAD CONNECTIONS

SUM PORT	2
PORT 1	6
PORT 2	4
GROUND	1,3,5
PORT 1-2	resistor external 100 ohms

PRODUCT MARKING: Z

DEMO BOARD MCL P/N: TB-SCW-2-332+  
SUGGESTED PCB LAYOUT (PL-727)

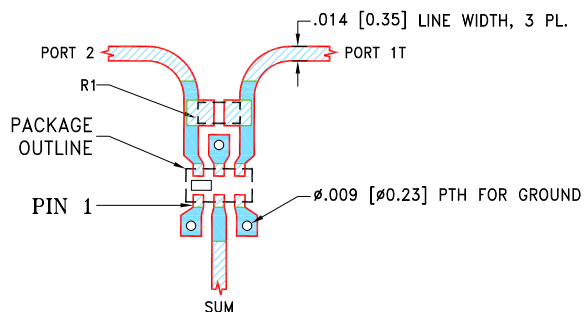

COMPONENT	SIZE
R1	0402

**NOTES:**

1. LINE WIDTH IS SHOWN FOR ROGERS RO4350B WITH DIELECTRIC THICKNESS .0066±.0007"; COPPER: 1/2 OZ. EACH SIDE. FOR OTHER MATERIALS LINE WIDTH MAY NEED TO BE MODIFIED.
2. CHIP COMPONENT FOOT PRINTS SHOWN FOR REFERENCE. FOR COMPONENT VALUES REFER TO TB-1224+.
3. BOTTOM SIDE OF THE PCB IS CONTINUOUS GROUND PLANE.

- DENOTES PCB COPPER LAYOUT WITH SMOBC (SOLDER MASK OVER BARE COPPER).
- DENOTES COPPER LAND PATTERN FREE OF SOLDER MASK.

## OUTLINE DRAWING

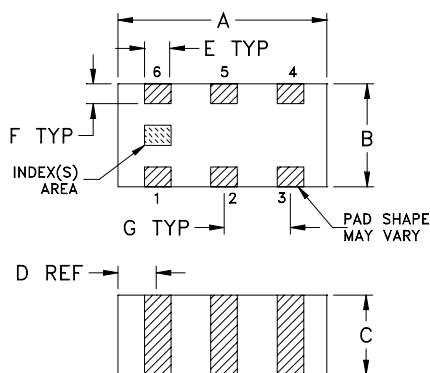

## PCB Land Pattern

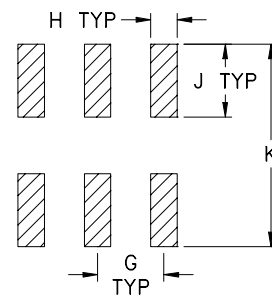

Suggested Layout,  
Tolerance to be within ±.002

## OUTLINE DIMENSIONS (Inches/mm)

A	B	C	D	E	F
.063	.031	.024	.012	.008	.006
1.60	0.79	0.61	0.30	0.20	0.15
G	H	J	K		wt
.020	.010	.022	.053		grams
0.51	0.25	0.56	1.35		0.005

## TAPE & REEL INFORMATION: F114



CERAMIC

# Power Splitter/Combiner

# SCW-2-332+

### TYPICAL PERFORMANCE DATA

Frequency (MHz)	Total Loss <sup>1</sup> (dB)		Amplitude Unbalance (dB)	Isolation (dB)	Phase Unbalance (deg.)	Return Loss (dB)		
	S-1	S-2				S	1	2
2400	3.41	3.35	0.07	14.80	1.53	15.40	31.77	28.06
2450	3.41	3.34	0.07	15.26	1.55	15.67	31.47	28.16
2500	3.41	3.34	0.07	15.74	1.59	15.93	31.06	27.88
2550	3.40	3.33	0.07	16.22	1.61	16.19	30.49	27.57
2600	3.40	3.33	0.07	16.73	1.63	16.44	29.79	27.45
2650	3.40	3.33	0.07	17.24	1.66	16.61	29.07	27.23
2700	3.40	3.32	0.07	17.74	1.68	16.77	28.32	26.69
2750	3.40	3.32	0.08	18.24	1.71	16.88	27.52	26.14
2800	3.40	3.32	0.07	18.74	1.73	16.93	26.64	25.79
2850	3.40	3.33	0.08	19.20	1.75	16.90	25.79	25.38
2900	3.41	3.33	0.08	19.61	1.77	16.80	24.98	24.75
3000	3.43	3.35	0.08	20.26	1.82	16.42	23.30	23.63
3100	3.46	3.37	0.08	20.50	1.87	15.76	21.78	22.49
3200	3.49	3.40	0.09	20.28	1.92	14.91	20.32	21.29
3300	3.54	3.45	0.10	19.64	1.98	13.93	18.99	20.11

1. Total Loss = Insertion Loss + 3dB splitter loss.

SCW-2-332+  
TOTAL LOSS

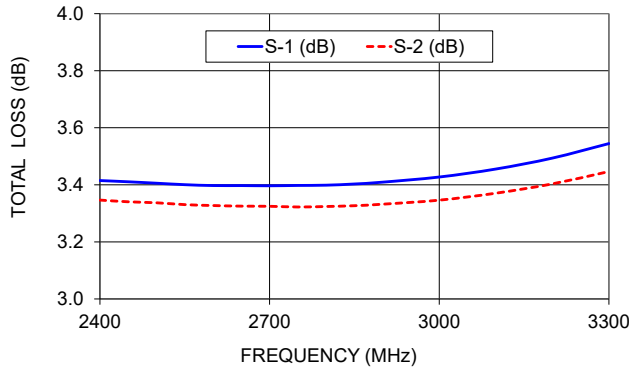

SCW-2-332+  
ISOLATION

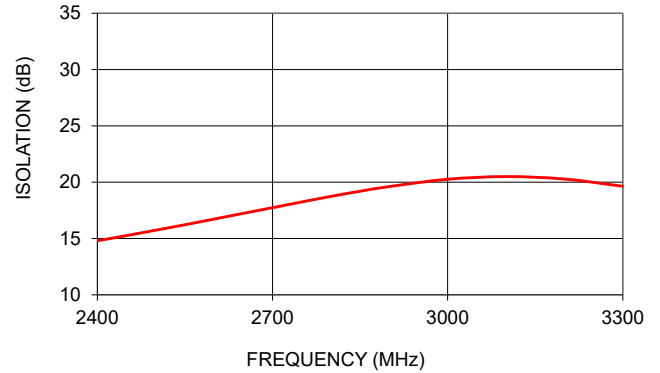

SCW-2-332+  
RETURN LOSS

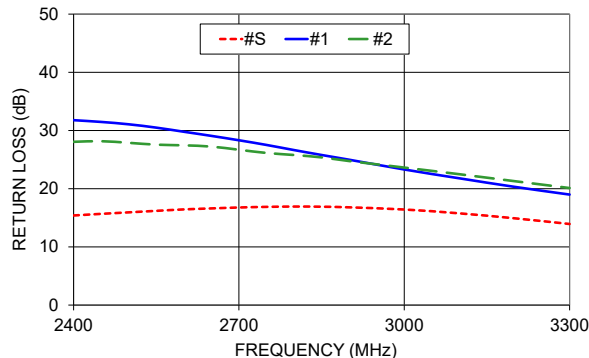

- NOTES**
- A. Performance and quality attributes and conditions not expressly stated in this specification document are intended to be excluded and do not form a part of this specification document.
  - B. Electrical specifications and performance data contained in this specification document are based on Mini-Circuit's applicable established test performance criteria and measurement instructions.
  - C. The parts covered by this specification document are subject to Mini-Circuits standard limited warranty and terms and conditions (collectively, "Standard Terms"); Purchasers of this part are entitled to the rights and benefits contained therein. For a full statement of the standard. Terms and the exclusive rights and remedies thereunder, please visit Mini-Circuits' website at [www.minicircuits.com/MCLStore/terms.jsp](http://www.minicircuits.com/MCLStore/terms.jsp)



## Typical Performance Data

FREQUENCY (MHz)	TOTAL LOSS <sup>1</sup> (dB)		AMPLITUDE UNBALANCE (dB)	ISOLATION (dB) 1-2	PHASE UNBALANCE (deg.)	FREQUENCY (MHz)	VSWR (:1)		
	S-1	S-2					S	1	2
2400	3.41	3.35	0.07	14.80	1.53	2400	1.41	1.05	1.08
2420	3.41	3.34	0.07	14.99	1.54	2420	1.40	1.05	1.08
2440	3.41	3.34	0.07	15.17	1.55	2440	1.40	1.05	1.08
2460	3.41	3.34	0.07	15.36	1.56	2460	1.39	1.06	1.08
2480	3.41	3.34	0.07	15.55	1.58	2480	1.39	1.06	1.08
2500	3.41	3.34	0.07	15.74	1.59	2500	1.38	1.06	1.08
2520	3.40	3.33	0.07	15.93	1.60	2520	1.37	1.06	1.09
2540	3.40	3.33	0.07	16.13	1.61	2540	1.37	1.06	1.09
2560	3.40	3.33	0.07	16.32	1.62	2560	1.36	1.06	1.09
2580	3.40	3.33	0.07	16.53	1.62	2580	1.36	1.06	1.09
2600	3.40	3.33	0.07	16.73	1.63	2600	1.35	1.07	1.09
2620	3.40	3.33	0.07	16.93	1.64	2620	1.35	1.07	1.09
2640	3.40	3.32	0.07	17.14	1.65	2640	1.35	1.07	1.09
2660	3.40	3.32	0.07	17.34	1.66	2660	1.35	1.07	1.09
2680	3.40	3.32	0.07	17.53	1.67	2680	1.34	1.08	1.09
2700	3.40	3.32	0.07	17.74	1.68	2700	1.34	1.08	1.10
2720	3.40	3.32	0.07	17.94	1.70	2720	1.34	1.08	1.10
2740	3.40	3.32	0.07	18.14	1.71	2740	1.34	1.09	1.10
2760	3.40	3.32	0.07	18.35	1.72	2760	1.33	1.09	1.10
2780	3.40	3.32	0.07	18.55	1.73	2780	1.33	1.09	1.11
2800	3.40	3.32	0.07	18.74	1.73	2800	1.33	1.10	1.11
2820	3.40	3.32	0.08	18.93	1.74	2820	1.33	1.10	1.11
2840	3.40	3.33	0.08	19.11	1.75	2840	1.33	1.11	1.11
2860	3.40	3.33	0.08	19.29	1.75	2860	1.33	1.11	1.12
2880	3.41	3.33	0.08	19.45	1.77	2880	1.34	1.11	1.12
2900	3.41	3.33	0.08	19.61	1.77	2900	1.34	1.12	1.12
2920	3.41	3.33	0.08	19.77	1.79	2920	1.34	1.12	1.13
2940	3.42	3.34	0.08	19.91	1.80	2940	1.34	1.13	1.13
2960	3.42	3.34	0.08	20.04	1.80	2960	1.35	1.14	1.13
2980	3.42	3.34	0.08	20.16	1.81	2980	1.35	1.14	1.14
3000	3.43	3.35	0.08	20.26	1.82	3000	1.36	1.15	1.14
3020	3.43	3.35	0.08	20.34	1.83	3020	1.36	1.15	1.14
3040	3.44	3.35	0.08	20.41	1.84	3040	1.37	1.16	1.15
3060	3.44	3.36	0.08	20.45	1.85	3060	1.37	1.16	1.15
3080	3.45	3.36	0.08	20.48	1.86	3080	1.38	1.17	1.16
3100	3.46	3.37	0.08	20.50	1.87	3100	1.39	1.18	1.16
3120	3.46	3.38	0.09	20.49	1.88	3120	1.40	1.18	1.17
3140	3.47	3.38	0.09	20.46	1.89	3140	1.41	1.19	1.17
3160	3.48	3.39	0.09	20.42	1.90	3160	1.42	1.20	1.18
3180	3.49	3.40	0.09	20.36	1.91	3180	1.43	1.21	1.18
3200	3.49	3.40	0.09	20.28	1.92	3200	1.44	1.21	1.19
3220	3.50	3.41	0.09	20.18	1.93	3220	1.45	1.22	1.19
3240	3.51	3.42	0.09	20.06	1.94	3240	1.46	1.23	1.20
3260	3.52	3.43	0.09	19.93	1.95	3260	1.47	1.24	1.20
3280	3.53	3.44	0.09	19.79	1.97	3280	1.49	1.24	1.21
3300	3.54	3.45	0.10	19.64	1.98	3300	1.50	1.25	1.22

# 2 Way-0° Power Splitter/Combiner

# SCW-2-332+

## Typical Performance Curves

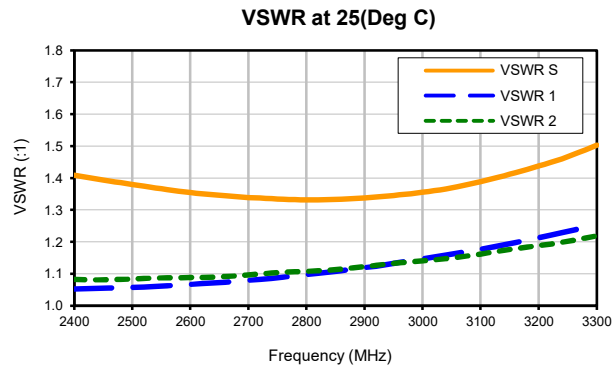
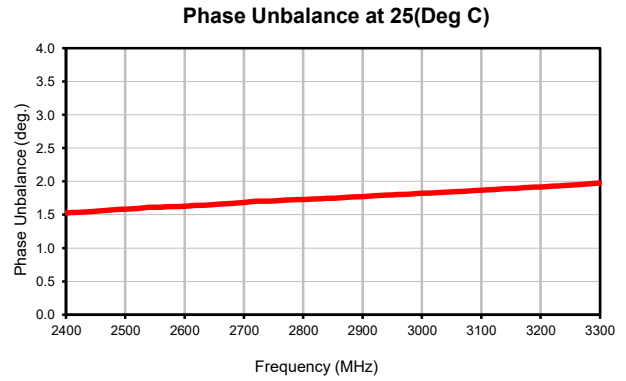
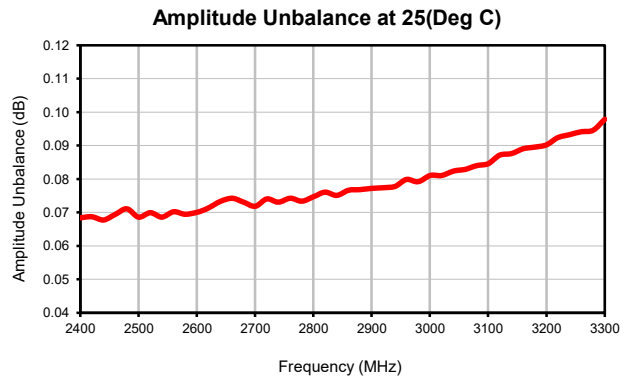
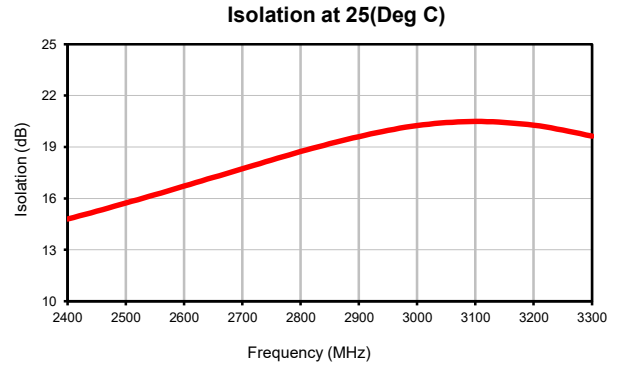
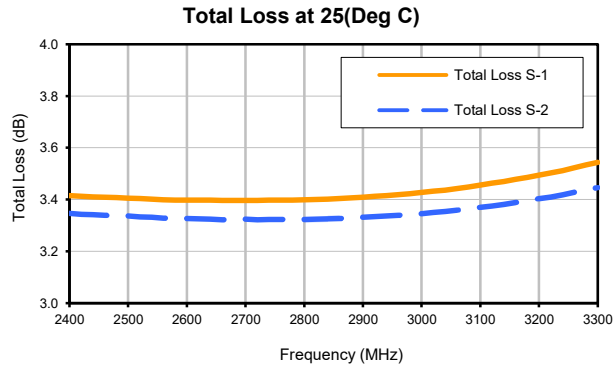

## Outline Dimensions

JC0603C

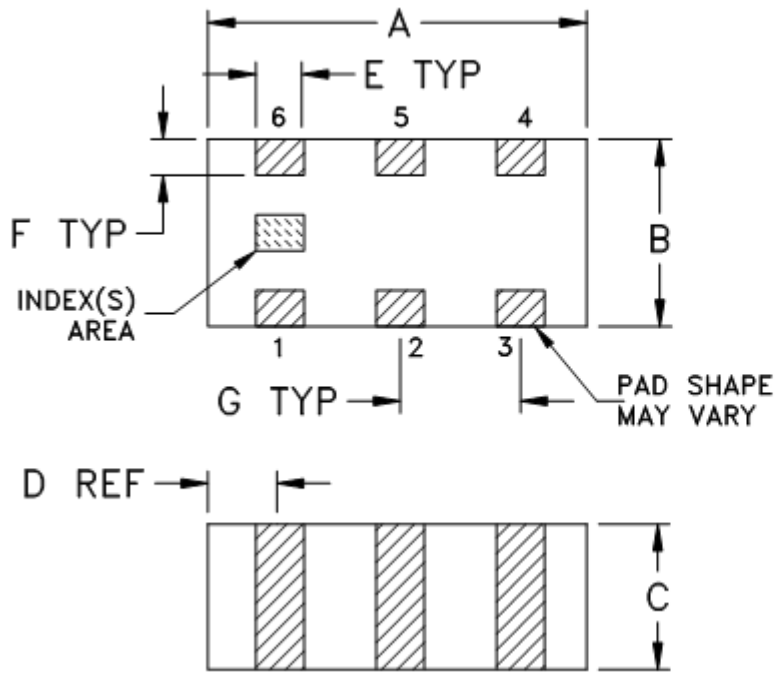

## PCB Land Pattern

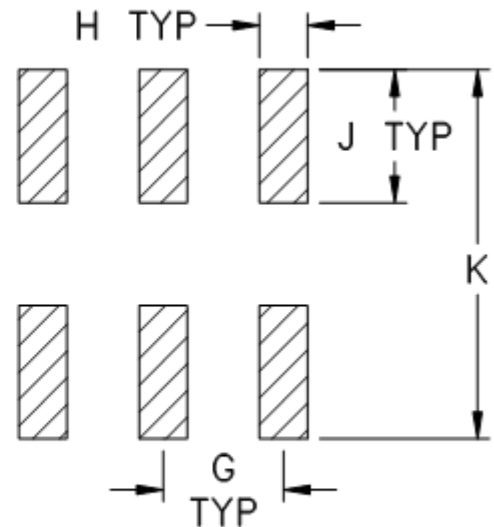

Suggested Layout,  
Tolerance to be within  $\pm .002$

CASE #	A	B	C	D	E	F	G	H	J	K	WT. GRAM
JC0603C	.063 (1.60)	.031 (0.80)	.024 (0.60)	.012 (0.30)	.008 (0.20)	.006 (0.15)	.020 (0.50)	.010 (0.25)	.022 (0.55)	0.053 (1.35)	.005

Dimensions are in inches (mm). Tolerances: 2 Pl.  $\pm .01$ ; 3 Pl.  $\pm .005$

### Notes:

- Open style, ceramic base.
- Termination finish:  
For RoHS Case Styles: Tin plate over Nickel plate. All models, (+) suffix.



P.O. Box 350166, Brooklyn, New York 11235-0003 (718) 934-4500 Fax (718) 332-4661 For detailed performance specs & shopping online see Mini-Circuits web site



The Design Engineers Search Engine Provides ACTUAL Data Instantly From MINI-CIRCUITS At: [www.minicircuits.com](http://www.minicircuits.com)

RF/IF MICROWAVE COMPONENTS

# Tape & Reel Packaging TR-F114

## DEVICE ORIENTATION IN T&R

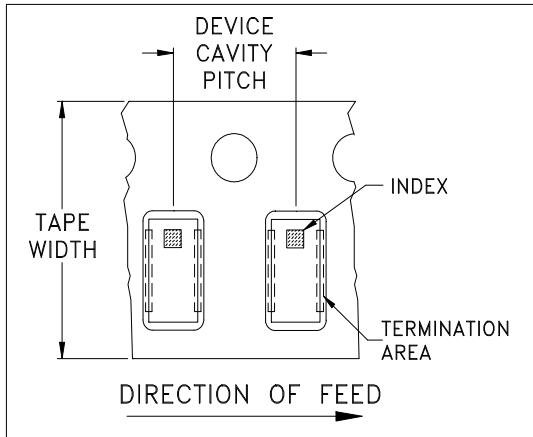

ILLUSTRATION 1

Applicable Case Styles	
GE0805C	JC0603C
GE0805C-1	JC0603C-4
GE0805C-1AP	JC0603C-6
GE0805C-7	
GE0805C-9	
GE0805C-10	
GE0805C-11	
GE0805C-12	

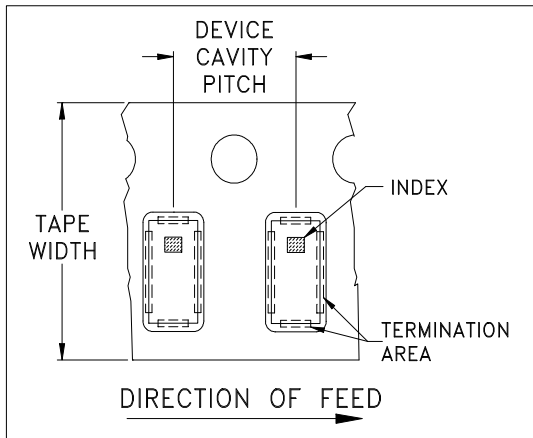

ILLUSTRATION 2

Applicable Case Styles	
GE0805C-2	JC0603C-1
GE0805C-3	JC0603C-2
GE0805C-4	JC0603C-3
GE0805C-5	JC0603C-5
GE0805C-6	JC0603C-7
GE0805C-8	JV1210C-1
GE0805C-15	

Tape Width, mm	Device Cavity Pitch, mm	Reel Size, inches	Devices per Reel	
8	4	7	Small quantity standards (see note)	20
				50
				100
				200
				500
				1000
			Standard	4000

Note: Please Consult individual model data sheet to determine device per reel availability.

Mini-Circuits carrier tape materials provide protection from ESD (Electro-Static Discharge) during handling and transportation. Tapes are static dissipative and comply with industry standards EIA-481/EIA-541.

Go to: [www.minicircuits.com/pages/pdfs/tape.pdf](http://www.minicircuits.com/pages/pdfs/tape.pdf)



INTERNET <http://www.minicircuits.com>

P.O. Box 350166, Brooklyn, New York 11235-0003 (718) 934-4500 Fax (718) 332-4661

Distribution Centers NORTH AMERICA 800-654-7949 • 417-335-5935 • Fax 417-335-5945 • EUROPE 44-1252-832600 • Fax 44-1252-837010

Mini-Circuits ISO 9001 & ISO 14001 Certified



THIRD ANGLE PROJECTION

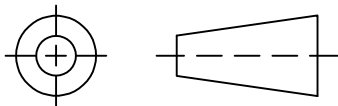

REVISIONS

REV	ECN No.	DESCRIPTION	DATE	DR	AUTH
OR	ECO-011925	NEW RELEASE	02/17/22	ITG	IL

SUGGESTED MOUNTING CONFIGURATION FOR  
JC0603C CASE STYLE

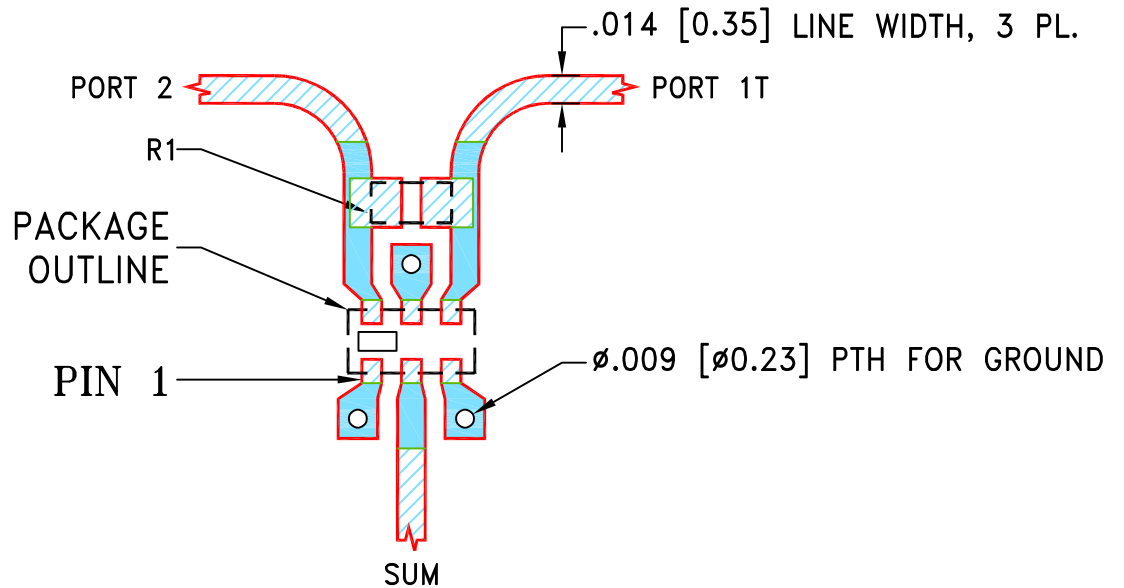

COMPONENT	SIZE
R1	0402

NOTES:

1. LINE WIDTH IS SHOWN FOR ROGERS R04350B WITH DIELECTRIC THICKNESS  $.0066 \pm .0007$ ”; COPPER: 1/2 OZ. EACH SIDE.  
FOR OTHER MATERIALS LINE WIDTH MAY NEED TO BE MODIFIED.
2. CHIP COMPONENT FOOT PRINTS SHOWN FOR REFERENCE. FOR COMPONENT VALUES REFER TO TB-1224+.
3. BOTTOM SIDE OF THE PCB IS CONTINUOUS GROUND PLANE.



DENOTES PCB COPPER LAYOUT WITH SMOBC (SOLDER MASK OVER BARE COPPER).



DENOTES COPPER LAND PATTERN FREE OF SOLDER MASK.

UNLESS OTHERWISE SPECIFIED	INITIALS	DATE
DIMENSIONS ARE IN INCHES	DRAWN ITG	02/17/22
TOLERANCES ON:	CHECKED GF	02/17/22
2 PL DECIMALS ±	APPROVED IL	02/17/22
3 PL DECIMALS ± .005		
ANGLES ±		
FRACTIONS ±		



Mini-Circuits®

13 Neptune Avenue  
Brooklyn NY 11235

PL, SCW-2series, JC0603C, TB-1224+

Mini-Circuits®  
THIS DOCUMENT AND ITS CONTENTS ARE THE PROPERTY OF MINI-CIRCUITS. EXCEPT FOR USE EXPRESSLY GRANTED, IN WRITING, TO ITS VENDORS, VENDEE AND THE UNITED STATES GOVERNMENT, MINI-CIRCUITS RESERVES ALL PROPRIETARY DESIGN, USE, MANUFACTURING AND REPRODUCTION RIGHTS THERETO. THESE CONTENTS SHALL NOT BE USED, DUPLICATED OR DISCLOSED TO ANY OUTSIDE PARTY, IN WHOLE OR IN PART, WITHOUT WRITTEN PERMISSION OF MINI-CIRCUITS.

SIZE	CODE IDENT	DRAWING NO:	REV:
A	15542	98-PL-727	OR
FILE:	98PL727	SCALE:	SHEET:
		10:1	1 OF 1

# Evaluation Board and Circuit

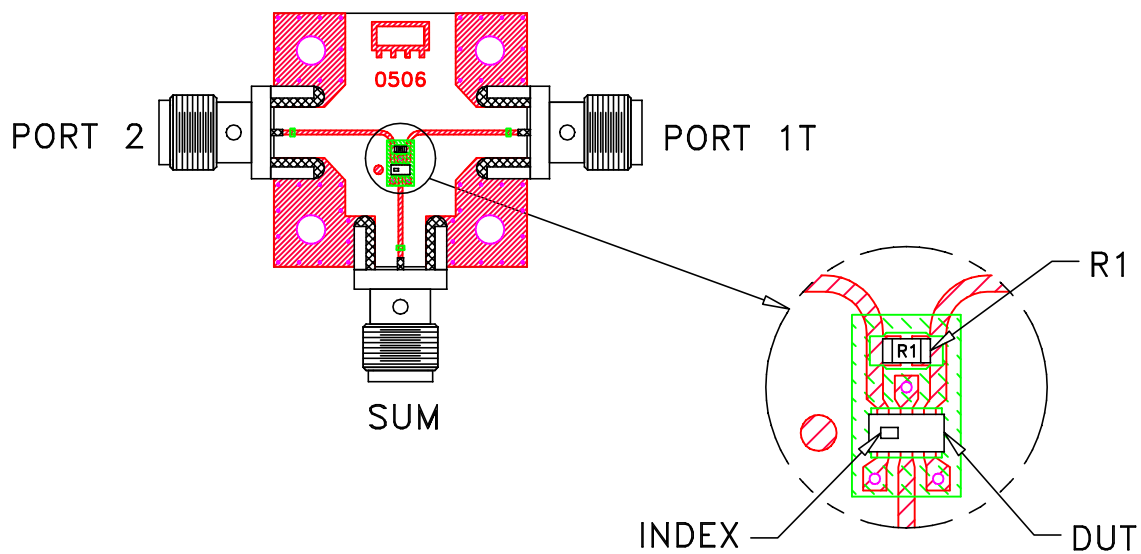

TB-1224+

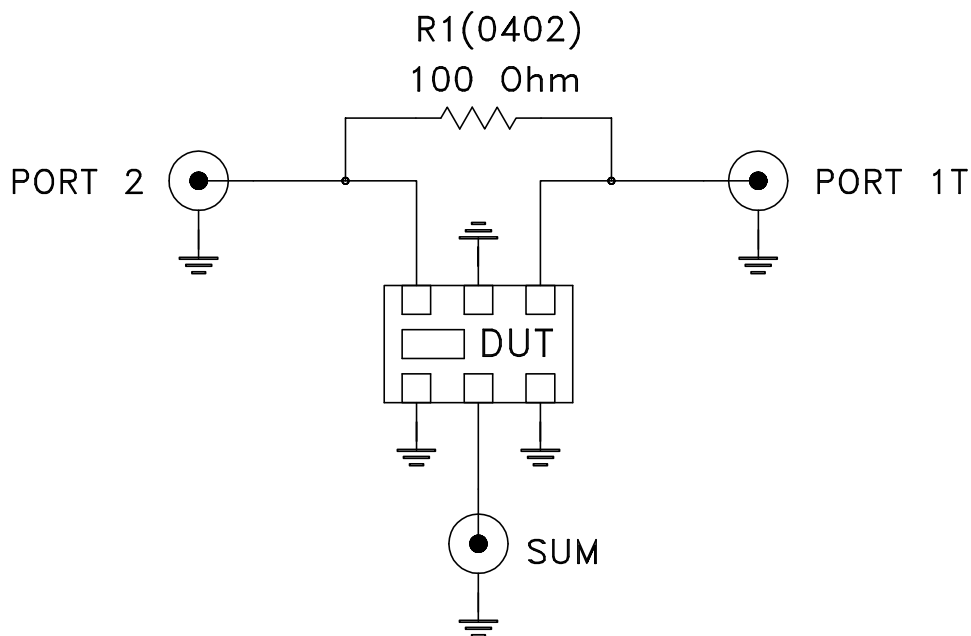

Schematic Diagram

## Notes:

1. 50 Ohm SMA Female connectors.
2. PCB Material: R04350 or equivalent,  
Dielectric Constant=3.5, Thickness=.0066 inch.

 **Mini-Circuits®**



All Mini-Circuits products are manufactured under exacting quality assurance and control standards, and are capable of meeting published specifications after being subjected to any or all of the following physical and environmental test.

Specification	Test/Inspection Condition	Reference/Spec
Operating Temperature	-55° to 125° C Ambient Environment	Individual Model Data Sheet
Storage Temperature	-55° to 125° C Ambient Environment	Individual Model Data Sheet
Humidity	90 to 95% RH, 240 hours, 50°C	MIL-STD-202, Method 103, Condition A, Except 50°C and end-point electrical test done within 12 hours
Solder Reflow Heat	Sn-Pb Eutectic Process: 225°C peak Pb-Free Process: 250°C peak	J-STD-020C, Table 4-1, 4-2 and 5-2; Figure 5-1
Solderability	10X Magnification	J-STD-002, Para 4.2.5, Test S, 95% Coverage
Vibration (High Frequency)	20g peak, 10-2000 Hz, 12 times in each of three perpendicular directions (total 36)	MIL-STD-202, Method 204, Condition D
Mechanical Shock	50g, 11 ms, 1/2-sine, 18 shocks: 3 each direction, each of 3 axes	MIL-STD-202, Method 213, Condition A