

SURFACE MOUNT

RF Transformer

SCTX1-83-2W+

50Ω 10 to 8000 MHz 1:1 Ratio

THE BIG DEAL

- Super Wideband, 10 to 8000 MHz
- Low Insertion Loss, 2.8 dB typ. up to 8 GHz
- Amplitude Unbalance, ± 0.9 dB typ. up to 6 GHz
- Good Input Return Loss, 10 dB typ.
- Low Phase Unbalance, $\pm 9^\circ$ typ.
- Common Mode Rejection, 20 dB typ.



Generic photo used for illustration purposes only

CASE STYLE: SN2595

+RoHS Compliant

The +Suffix identifies RoHS Compliance. See our website for methodologies and qualifications

APPLICATIONS

- Defense Communication
- Defense Radar
- Line of sight links
- PCS
- Cellular
- Wideband push-pull amplifiers
- ADC (Analog to Digital Converter)
- Balanced Receivers

PRODUCT OVERVIEW

Mini-Circuits' SCTX1-83-2W+ is a surface-mount transmission line transformer (core and Semi-Rigid cable) covering a very wide frequency range from 10 to 8000 MHz. The transformer provides low insertion loss with excellent phase and amplitude performance. Featuring core and cable construction on a 12-lead PCB unit measures 0.60 x 0.60 x 0.15" accommodating dense circuit board layouts.

KEY FEATURES

Feature	Advantages
Wideband, 10 to 8000 MHz	Super wide frequency range covers bandwidth requirements for many broadband applications.
Low insertion loss, 2.8 dB	SCTX1-83-2W+ provides excellent signal transmission from input to output with consistent performance across its entire frequency range.
Good Phase and Amplitude Unbalance	Provides good CMRR and IP2.
Small size (0.60 x 0.60 x 0.15")	Provide good solderability and tight layouts.

REV. B
ECO-020468
SCTX1-83-2W+
MCL NY
240410





SURFACE MOUNT

RF Transformer

SCTX1-83-2W+



50Ω 10 to 8000 MHz 1:1 Ratio

ELECTRICAL SPECIFICATIONS AT 25°C

Parameter	Frequency (MHz)	Min.	Typ.	Max.	Unit
Impedance Ratio (secondary/primary)		1			
Frequency Range		10		8000	MHz
Insertion Loss (Average)	10 - 3000	—	1.9	2.8	dB
	3000 - 6000	—	2.8	3.9	
	6000 - 8000	—	3.9	4.9	
Amplitude Unbalance (±)	10 - 3000	—	0.3	0.6	dB
	3000 - 6000	—	0.6	1.1	
	6000 - 8000	—	0.9	1.5	
Phase Unbalance (±)	10 - 3000	—	3	6	Degree
	3000 - 6000	—	5	9	
	6000 - 8000	—	9	12	
Common mode rejection	10 - 4500	20	25	—	dB
	4500 - 8000	16	20	—	

ABSOLUTE MAXIMUM RATINGS

Parameter	Ratings
Operating Temperature	-40°C to 85°C
Storage Temperature	-55°C to 100°C
RF Power	2W

Permanent damage may occur if any of these limits are exceeded.

CONFIGURATION G

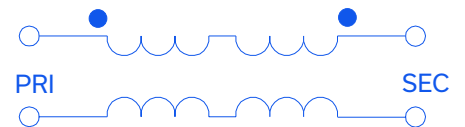



SURFACE MOUNT

RF Transformer

SCTX1-83-2W+



50Ω 10 to 8000 MHz 1:1 Ratio

PIN CONNECTIONS

PRIMARY DOT	12
PRIMARY (GND)	11
SECONDARY DOT	3
SECONDARY	4
GROUND	ALL OTHERS

PRODUCT MARKING: N/A

DEMO BOARD MCL P/N: TB-SCTX1-83-2W+ SUGGESTED PCB LAYOUT (PL-595)

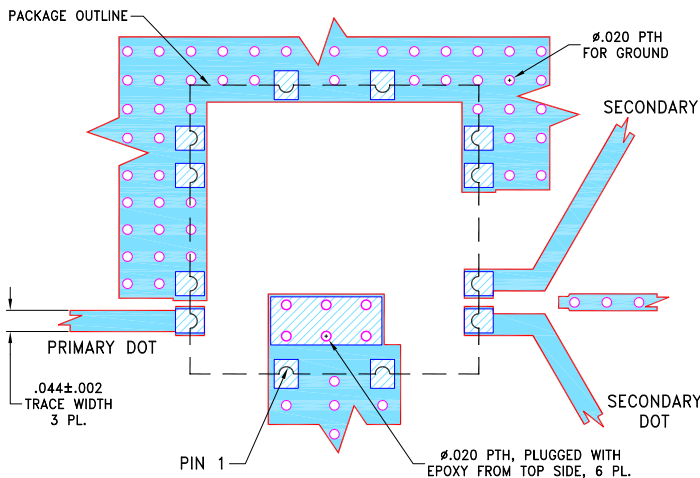

NOTES:

- TRACE WIDTH IS SHOWN FOR ROGERS R04350B, WITH DIELECTRIC THICKNESS $.020 \pm .0015$ ". COPPER: 1/2 Oz. EACH SIDE. FOR OTHER MATERIALS TRACE WIDTH MAY NEED TO BE MODIFIED.
- BOTTOM SIDE OF THE PCB IS CONTINUOUS GROUND PLANE.

- DENOTES PCB COPPER LAYOUT WITH SMOBC (SOLDER MASK OVER BARE COPPER)
- DENOTES COPPER LAND PATTERN FREE OF SOLDERMASK

OUTLINE DRAWING

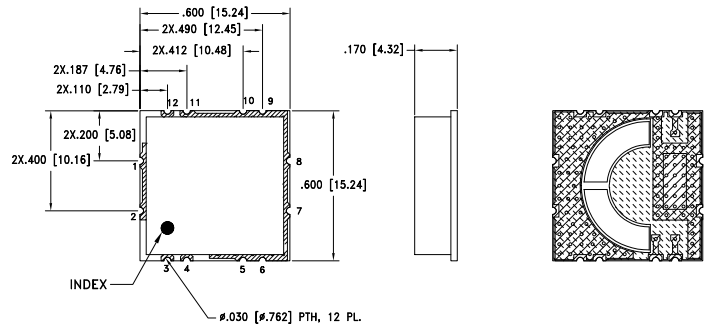

TOP VIEW

BOTTOM VIEW

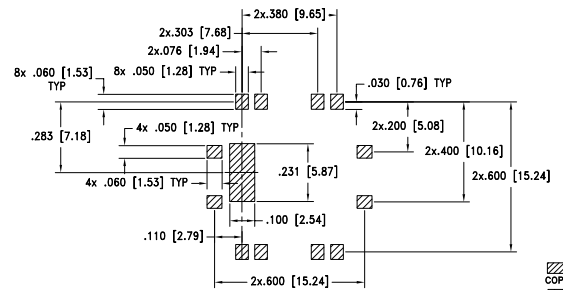

PCB LAND PATTERN
SUGGESTED LAYOUT
TOLERANCE TO BE WITHIN $\pm .002$



Weight: 1.2 gram
Dimensions are in inches [mm]. Tolerances: 3 PL $\pm .005$ Inch

TAPE & REEL INFORMATION: F95



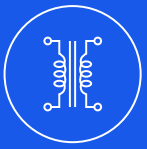

SURFACE MOUNT

RF Transformer

SCTX1-83-2W+

Mini-Circuits

50Ω 10 to 8000 MHz 1:1 Ratio

TYPICAL PERFORMANCE DATA

Frequency (MHz)	Insertion Loss (dB)	Input Return Loss (dB)	Amplitude Unbalance (dB)	Phase Unbalance (deg)
10	1.13	19.06	0.04	1.62
100	1.16	19.26	0.04	0.23
500	1.18	18.54	0.00	0.07
1000	1.25	15.62	0.00	0.02
2000	1.35	12.91	-0.11	0.23
3800	1.68	16.99	0.11	1.70
5000	2.63	7.52	0.42	2.44
6000	2.79	6.34	-0.12	3.56
7000	1.97	10.86	-0.63	1.47
8000	2.20	14.72	-0.67	1.90

SCTX1-83-2W+
INSERTION LOSS

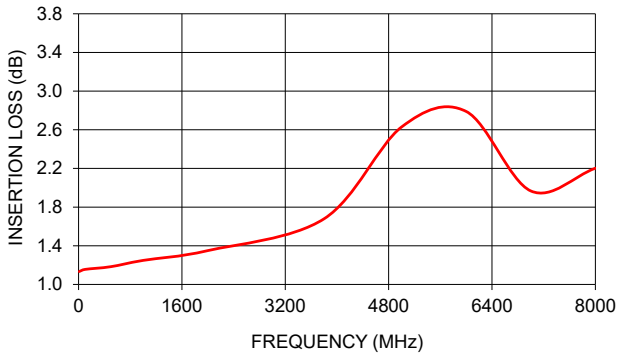

SCTX1-83-2W+
INPUT RETURN LOSS

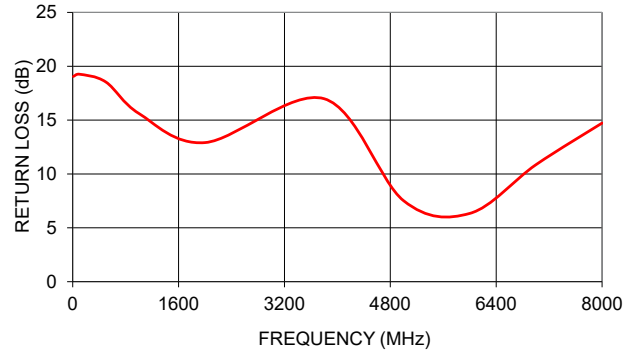

SCTX1-83-2W+
AMPLITUDE UNBALANCE

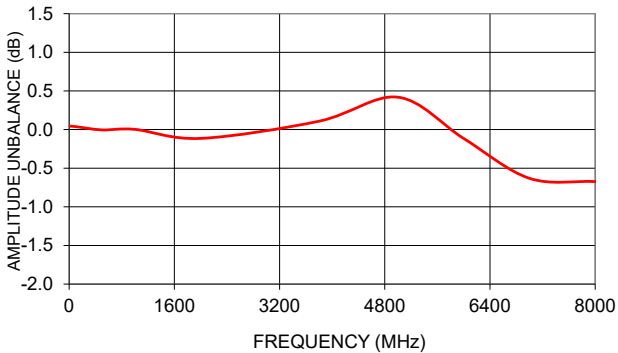

SCTX1-83-2W+
PHASE UNBALANCE

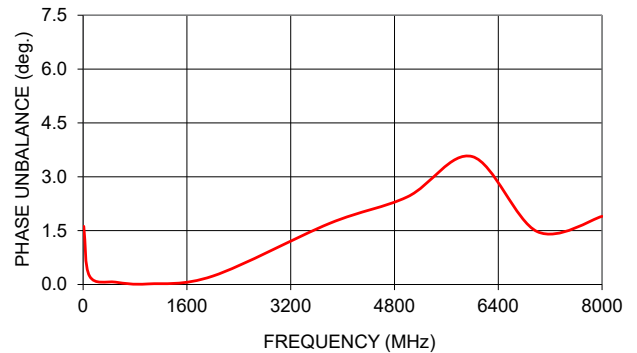

NOTES

- A. Performance and quality attributes and conditions not expressly stated in this specification document are intended to be excluded and do not form a part of this specification document.
- B. Electrical specifications and performance data contained in this specification document are based on Mini-Circuit's applicable established test performance criteria and measurement instructions.
- C. The parts covered by this specification document are subject to Mini-Circuits standard limited warranty and terms and conditions (collectively, "Standard Terms"); Purchasers of this part are entitled to the rights and benefits contained therein. For a full statement of the standard. Terms and the exclusive rights and remedies thereunder, please visit Mini-Circuits' website at www.minicircuits.com/terms/viewterm.html



RF Transformer

SCTX1-83-2W+

Typical Performance Data

FREQUENCY MHz	INSERTION LOSS (dB)	INPUT RETURN LOSS (dB)	AMPLITUDE UNBALANCE (dB)	PHASE UNBALANCE (deg.)
3	1.21	17.60	0.24	4.93
5	1.15	18.44	0.11	3.21
7	1.13	18.81	0.07	2.32
10	1.13	19.06	0.04	1.62
20	1.14	19.20	0.04	0.74
30	1.15	19.22	0.04	0.48
40	1.15	19.23	0.04	0.38
50	1.15	19.25	0.05	0.32
60	1.16	19.27	0.04	0.28
70	1.16	19.28	0.04	0.27
80	1.16	19.30	0.04	0.25
90	1.16	19.30	0.04	0.24
100	1.16	19.26	0.04	0.23
200	1.17	19.33	0.03	0.21
300	1.17	19.18	0.01	0.17
400	1.18	18.92	0.00	0.13
500	1.18	18.54	0.00	0.07
600	1.19	18.03	-0.01	0.01
700	1.21	17.47	0.00	0.01
800	1.21	16.86	0.00	0.02
900	1.23	16.22	0.00	0.02
1000	1.25	15.62	0.00	0.02
1200	1.28	14.47	0.00	0.01
1400	1.31	13.53	-0.02	0.02
1600	1.33	12.92	-0.05	0.05
1800	1.35	12.70	-0.08	0.11
2000	1.35	12.91	-0.11	0.23
2200	1.34	13.65	-0.15	0.41
2400	1.32	14.96	-0.19	0.67
2600	1.31	17.01	-0.22	0.99
2800	1.32	20.19	-0.24	1.34
3000	1.35	25.29	-0.23	1.71
3200	1.39	39.67	-0.18	1.96
3400	1.46	28.73	-0.10	2.07
3600	1.55	21.25	0.00	1.99
3800	1.68	16.99	0.11	1.70
4000	1.83	14.09	0.22	1.21
4200	2.00	11.95	0.31	0.55
4400	2.17	10.33	0.38	0.25
4600	2.34	9.11	0.43	1.02
4800	2.50	8.21	0.44	1.79
5000	2.63	7.52	0.42	2.44
5200	2.75	7.01	0.36	2.96
5400	2.83	6.61	0.28	3.37
5600	2.87	6.36	0.16	3.63
5800	2.86	6.26	0.02	3.69
6000	2.79	6.34	-0.12	3.56
6200	2.66	6.62	-0.26	3.27
6400	2.50	7.17	-0.39	2.82
6600	2.32	8.00	-0.49	2.29
6800	2.14	9.20	-0.56	1.84
7000	1.97	10.86	-0.63	1.47
7100	1.89	12.03	-0.67	1.25
7200	1.83	13.50	-0.69	0.98
7300	1.80	15.39	-0.70	0.68
7400	1.78	18.07	-0.71	0.42
7500	1.79	21.52	-0.71	0.15
7600	1.82	25.41	-0.71	0.20
7700	1.88	24.24	-0.71	0.53
7800	1.96	20.21	-0.70	0.93
7900	2.07	16.98	-0.70	1.40
8000	2.20	14.72	-0.67	1.90
8100	2.37	13.02	-0.65	2.37
8200	2.54	11.70	-0.60	2.91
8300	2.74	10.66	-0.56	3.48
8400	2.96	9.86	-0.48	4.00
8500	3.20	9.18	-0.40	4.49



P.O. Box 350166, Brooklyn, New York 11235-0003 (718) 934-4500 • Fax (718) 332-4661 For detailed performance specs & shopping online see Mini-Circuits web site
 The Design Engineers Search Engine Provides ACTUAL Data Instantly From MINI-CIRCUITS At: www.minicircuits.com



IF/RF MICROWAVE COMPONENTS

REV. OR
 SYTX1-52HP+
 12/6/2018
 Page 1 of 1

Typical Performance Data

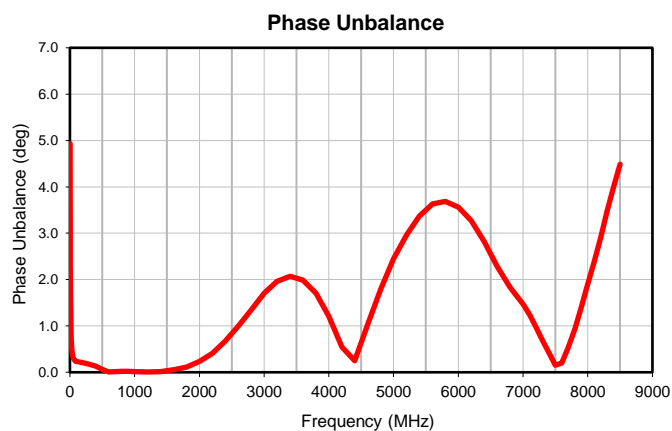
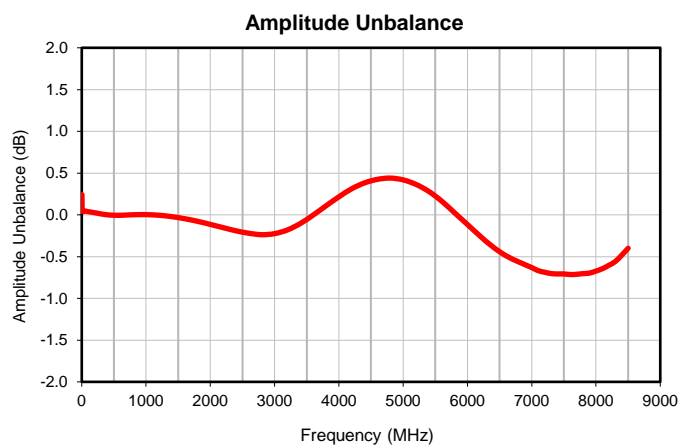
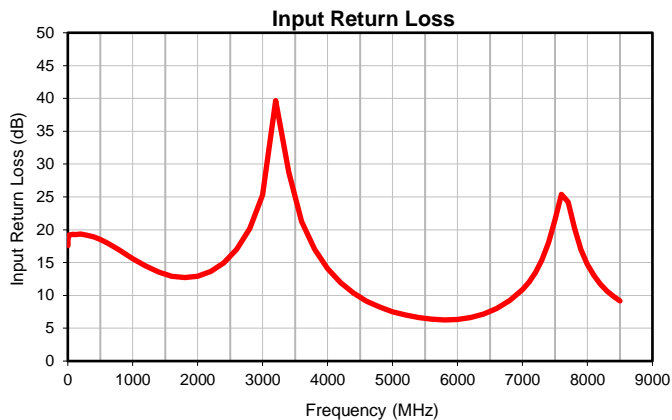
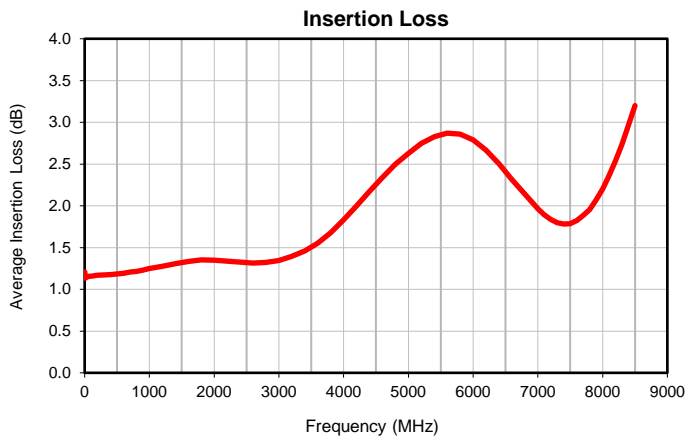

Outline Dimensions

SN2595

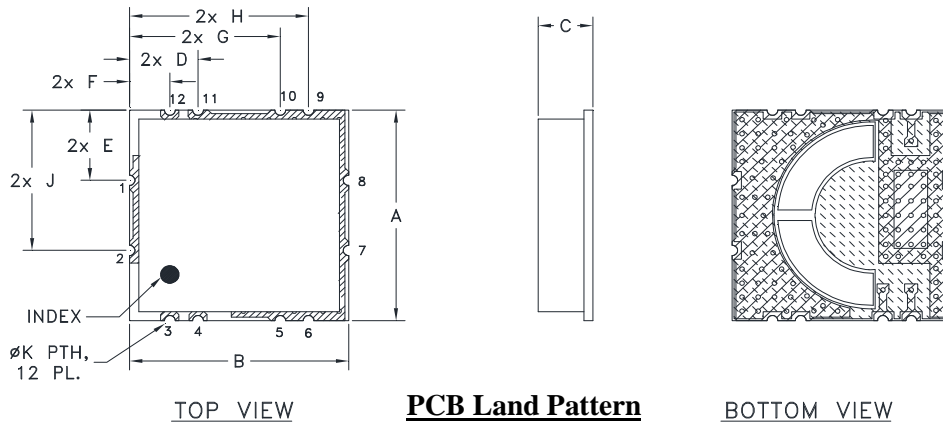

TOP VIEW

PCB Land Pattern

BOTTOM VIEW

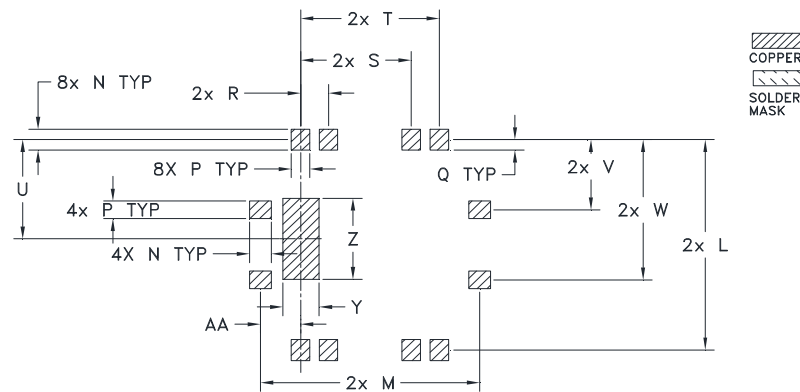

Suggested Layout,
Tolerance to be within ± 0.002

CASE #	A	B	C	D	E	F	G	H	J	K
SN2595	.600 (15.24)	.600 (15.24)	.170 (3.81)	.187 (4.76)	.200 (5.08)	.110 (2.79)	.412 (10.48)	.490 (12.45)	.400 (10.16)	.030 (0.762)

CASE #	L	M	N	P	Q	R	S	T	U	V
SN2595	.600 (15.24)	.600 (15.24)	.060 (1.53)	.050 (1.28)	.030 (.76)	.076 (1.94)	.303 (7.68)	.380 (9.65)	.283 (7.18)	.200 (5.08)

CASE #	W	Y	Z	AA	WT. GRAM
SN2595	.400 (10.16)	.100 (2.54)	.231 (5.87)	.110 (2.79)	1.2

Dimensions are in inches (mm). Tolerances: 3Pl. $\pm .005$

Notes:

- Case material: Nickel-Silver alloy.
- Base: Printed wiring laminate.
- Termination finish:
For RoHS Case Styles: 3-5 μ inch (.08-.13 microns) Gold over 120-240 μ inch (3.05-6.10 microns) Nickel plate.



P.O. Box 350166, Brooklyn, New York 11235-0003 (718) 934-4500 Fax (718) 332-4661 For detailed performance specs & shopping online see Mini-Circuits web site



The Design Engineers Search Engine Provides ACTUAL Data Instantly From MINI-CIRCUITS At: www.minicircuits.com

RF/IF MICROWAVE COMPONENTS

Tape & Reel Packaging TR-F95

DEVICE ORIENTATION IN T&R

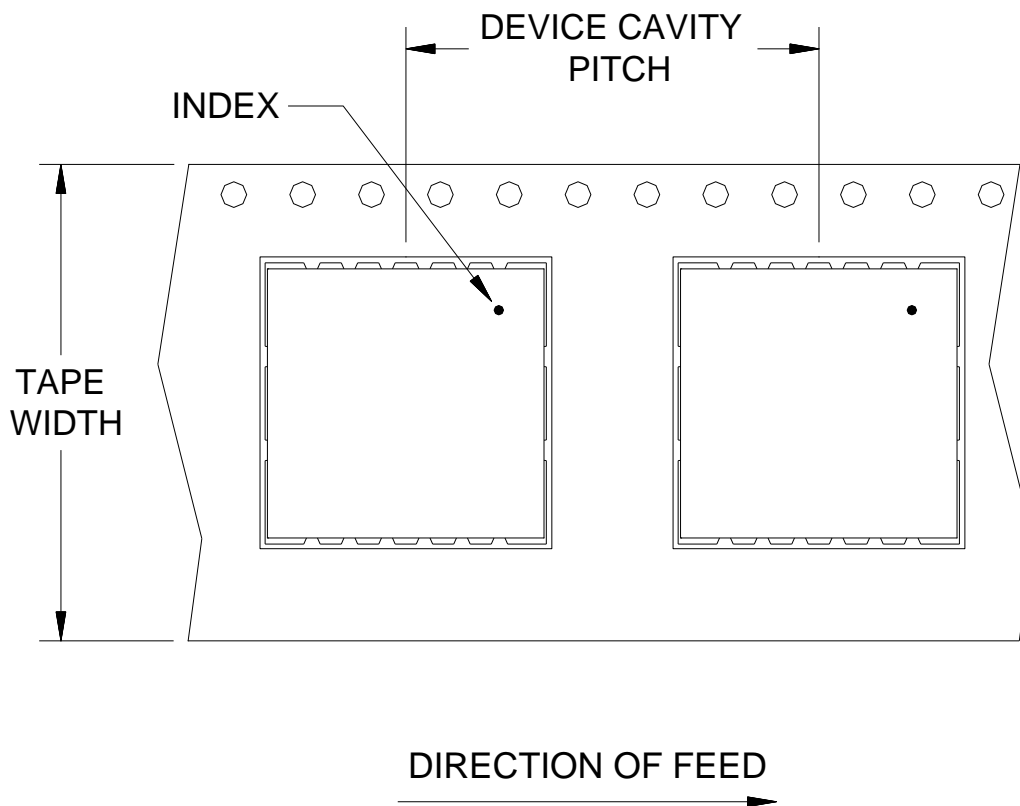

Tape Width, mm	Device Cavity Pitch, mm	Reel Size, inches	Devices per Reel	
24	24	13	Small quantity standards (see note)	20
				50
				100
				200
			Standard	500

Note: Please consult individual model data sheet to determine device per reel availability.

Mini-Circuits carrier tape materials provide protection from ESD (Electro-Static Discharge) during handling and transportation. Tapes are static dissipative and comply with industry standards EIA-481/EIA-541.

Go to: www.minicircuits.com/pages/pdfs/tape.pdf

Mini-Circuits®

INTERNET <http://www.minicircuits.com>

P.O. Box 350166, Brooklyn, New York 11235-0003 (718) 934-4500 Fax (718) 332-4661

Distribution Centers NORTH AMERICA 800-654-7949 • 417-335-5935 • Fax 417-335-5945 • EUROPE 44-1252-832600 • Fax 44-1252-837010

Mini-Circuits ISO 9001 & ISO 14001 Certified

THIRD ANGLE PROJECTION

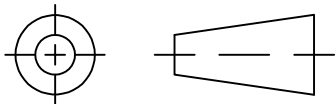

REVISIONS

REV	ECN No.	DESCRIPTION	DATE	DR	AUTH
OR	M168695	NEW RELEASE	06/28/18	ITG	WP
A	ECO-019969	CHANGED P/N OF TB, WAS TB-1005+	11/21/23	ITG	IL

SUGGESTED MOUNTING CONFIGURATION FOR SN2595 CASE STYLE

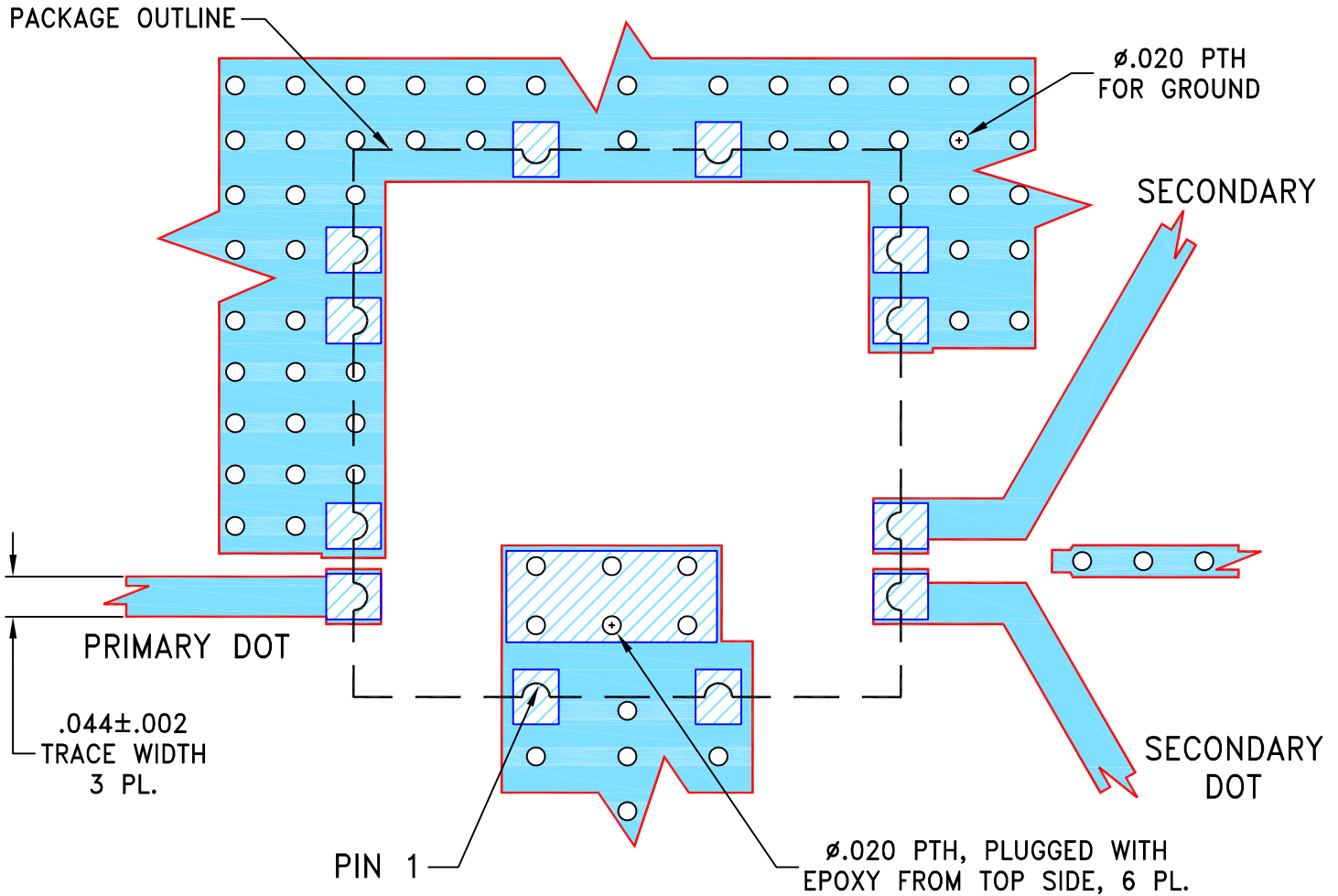

NOTES:

- TRACE WIDTH IS SHOWN FOR ROGERS R04350B, WITH DIELECTRIC THICKNESS .020±.0015". COPPER: 1/2 Oz. EACH SIDE.
FOR OTHER MATERIALS TRACE WIDTH MAY NEED TO BE MODIFIED.
- BOTTOM SIDE OF THE PCB IS CONTINUOUS GROUND PLANE.

- DENOTES PCB COPPER LAYOUT WITH SMOBC (SOLDER MASK OVER BARE COPPER)
- DENOTES COPPER LAND PATTERN FREE OF SOLDERMASK

UNLESS OTHERWISE SPECIFIED	INITIALS	DATE
DIMENSIONS ARE IN INCHES	DRAWN ITG	06/28/18
TOLERANCES ON:	CHECKED GF	06/28/18
2 PL DECIMALS ±	APPROVED WP	06/28/18
3 PL DECIMALS ± .005"		
ANGLES ±		
FRACTIONS ±		

Mini-Circuits® 13 Neptune Avenue
Brooklyn NY 11235

PL, SN2595, TB-SCTX2-93-2W+

SIZE A	CODE IDENT 15542	DRAWING NO: 98-PL-595	REV: A
FILE: 98PL595	SCALE: 5:1	SHEET: 1 OF 1	

Mini-Circuits®
THIS DOCUMENT AND ITS CONTENTS ARE THE PROPERTY OF MINI-CIRCUITS.
EXCEPT FOR USE EXPRESSLY GRANTED, IN WRITING, TO ITS VENDORS, VENDEE
AND THE UNITED STATES GOVERNMENT, MINI-CIRCUITS RESERVES ALL PROPRIETARY
DESIGN, USE, MANUFACTURING AND REPRODUCTION RIGHTS THERETO.
THESE CONTENTS SHALL NOT BE USED, DUPLICATED OR DISCLOSED TO ANY OUTSIDE
PARTY, IN WHOLE OR IN PART, WITHOUT WRITTEN PERMISSION OF MINI-CIRCUITS.

Evaluation Board and Circuit

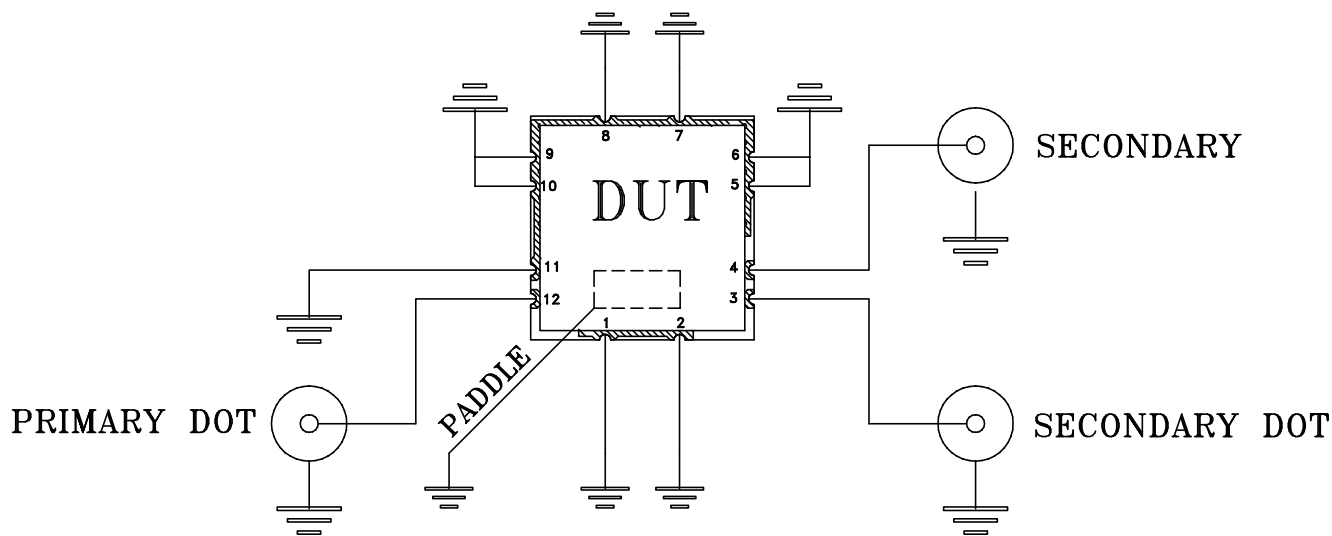
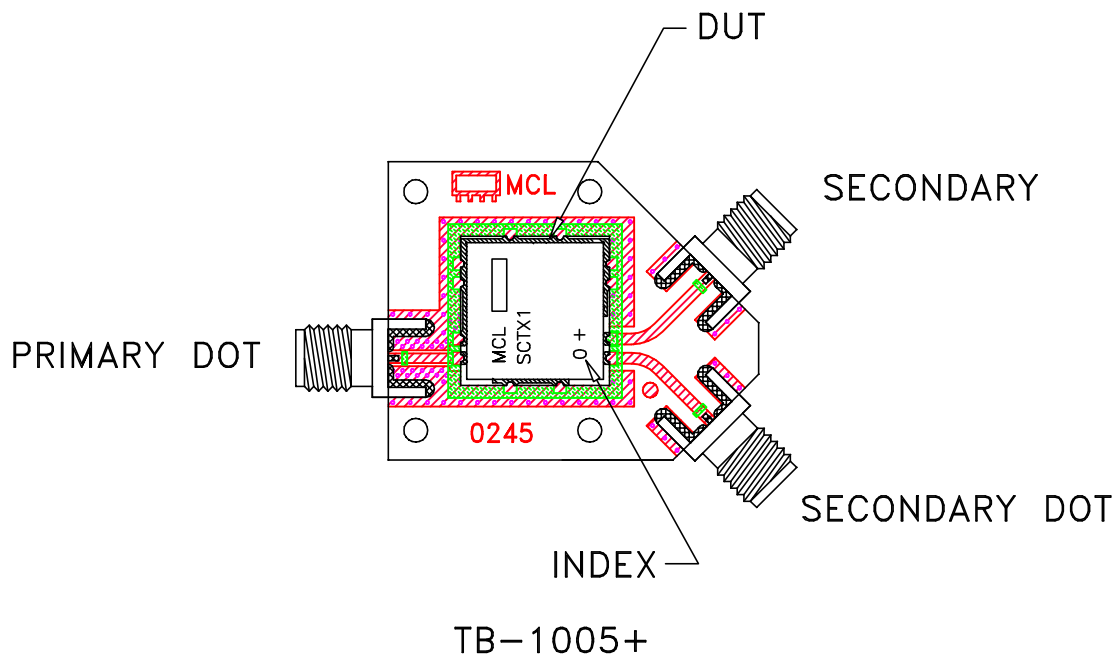

Schematic Diagram

Notes:

1. 50 Ohm SMA Female connectors.
2. PCB Material: R04350 or equivalent,
Dielectric Constant=3.5, Thickness=.020 inch.

 **Mini-Circuits®**



All Mini-Circuits products are manufactured under exacting quality assurance and control standards, and are capable of meeting published specifications after being subjected to any or all of the following physical and environmental test.

Specification	Test/Inspection Condition	Reference/Spec
Operating Temperature	-40° to 85°C Ambient Environment	Individual Model Data Sheet
Storage Temperature	-55° to 100° C Ambient Environment	Individual Model Data Sheet
Humidity	90 to 95% RH, 240 hours, 50°C	MIL-STD-202, Method 103, Condition A, Except 50°C and end-point electrical test done within 12 hours
Thermal Shock	-55° to 100°C, 100 cycles	MIL-STD-202, Method 107, Condition A-3, except +100°C
Solder Reflow Heat	Sn-Pb Eutetic Process: 225°C peak Pb-Free Process 245° - 250°C peak	J-STD-020, Table 4-1, 4-2 and 5-2, Figure 5-1
Solderability	10X Magnification	J-STD-002, 95% Coverage
Vibration (High Frequency)	20g peak, 10-2000 Hz, 12 times in each of three perpendicular directions (total 36)	MIL-STD-202, Method 204, Condition D
Mechanical Shock	50g, 11 ms, 1/2-sine, 18 shocks: 3 each direction, each of 3 axes	MIL-STD-202, Method 213, Condition A
Marking Resistance to Solvents	Isopropyl alcohol + mineral spirits at 25°C; terpene defluxer at 25°C; distilled water + proylene glycol monomethyl ether + monoethanolamine at 63°C to 70°C	MIL-STD-202, Method 215