



CERAMIC

Power Splitter / Combiner

SCG-3-752+

3 Way-0° 50Ω 4500 to 7500 MHz

THE BIG DEAL

- Isolation resistor, external 150 ohms
- Low insertion loss, 1.3 dB typ.
- Excellent phase unbalance, 5 deg. typ.
- Wrap around terminations for excellent solderability



Generic photo used for illustration purposes only

CASE STYLE: GE0805C-1

APPLICATIONS

- WIFI6
- 5G sub 6GHz

+RoHS Compliant

The +Suffix identifies RoHS Compliance. See our website for methodologies and qualifications

PRODUCT OVERVIEW

Mini-Circuits new LTCC 0° Power Splitter, model SCG-3-752+, offers industry leading combination of operating performance and size.

KEY FEATURES

Features	Advantages
Small Size	Offered in the package size, SCG-3-752+ offers an industry leading combination of size, power handling, and frequency. The small footprint allows for reduced parasitics in systems with improved performance and simplified layout.
Wrap-Around Terminations	Provides excellent solderability and easy visual inspection.
LTCC Construction	Provides repeatable performance in the rugged, ceramic package well suited for tough environments such as high humidity and temperature extremes.



CERAMIC

Power Splitter / Combiner

SCG-3-752+

Mini-Circuits

3 Way-0° 50Ω 4500 to 7500 MHz

ELECTRICAL SPECIFICATIONS¹ AT 25°C

Parameter	Frequency (MHz)	Min.	Typ.	Max.	Unit
Frequency Range		4500		7500	MHz
Average Insertion Loss, above 4.8 dB	4500 - 7500	—	1.3	2.1	dB
Isolation	4500 - 7500	11	14	—	dB
Phase Unbalance	4500 - 7500	—	5	10	Degree
Amplitude Unbalance	4500 - 7500	—	0.8	1.2	dB
Return Loss (Input)	4500 - 7500	—	10	—	dB
Return Loss (Output)	4500 - 7500	—	10	—	dB

Tested on TB-SCG-3-752+. Evaluation Board losses have been de-embedded.

MAXIMUM RATINGS

Parameter	Ratings
Operating Temperature	-55°C to 125°C
Storage Temperature	-55°C to 125°C
Input Power	2W* max.

Permanent damage may occur if any of these limits are exceeded.

ELECTRICAL SCHEMATIC

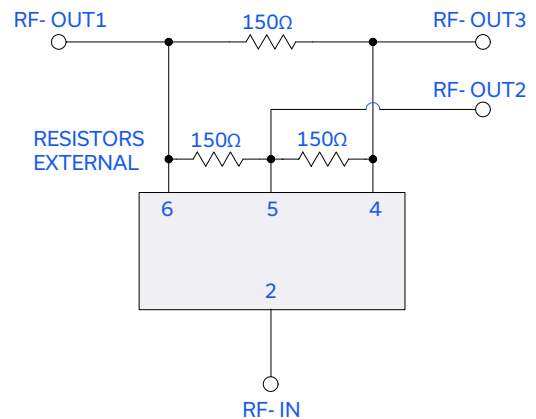



CERAMIC

Power Splitter / Combiner

SCG-3-752+

Mini-Circuits

3 Way-0° 50Ω 4500 to 7500 MHz

PAD CONNECTIONS



SUM PORT 2	2
PORT 1	6
PORT 2	5
PORT 3	4
GROUND	1,3
PORT 1-2, 2-3, 1-3	resistor external 150 ohms

PRODUCT MARKING: PT

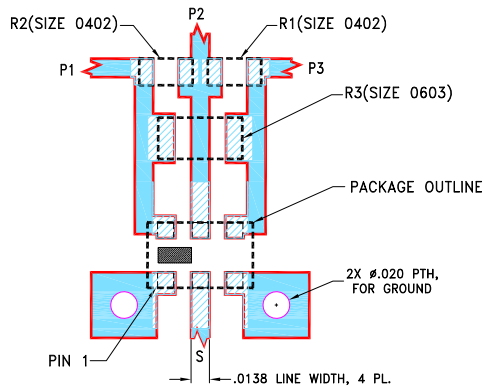
DEMO BOARD MCL P/N: TB-SCG-3-752+ SUGGESTED PCB LAYOUT (PL-621)



NOTES:

1. LINE WIDTH IS SHOWN FOR ROGERS R04350B WITH DIELECTRIC THICKNESS .0066±.0007. COPPER: 1/2 OZ. EACH SIDE. FOR OTHER MATERIALS LINE WIDTH MAY NEED TO BE MODIFIED.
 2. UNIT FOOT PRINT IS OPTIMIZED FOR PERFORMANCE AND IS DIFFERENT FROM CASE STYLE GE0805C-1 RECOMMENDATIONS.
 3. CHIP COMPONENT FOOT PRINT IS SHOWN FOR REFERENCE. FOR COMPONENT VALUE REFER TO TB-1018+.
 4. BOTTOM SIDE OF THE PCB IS CONTINUOUS GROUND PLANE.
-  DENOTES PCB COPPER LAYOUT WITH SMOBC (SOLDER MASK OVER BARE COPPER).
 DENOTES COPPER LAND PATTERN FREE OF SOLDER MASK.

OUTLINE DRAWING

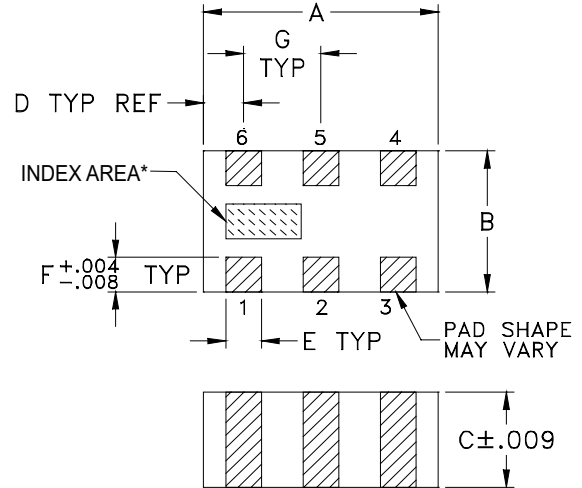

*Shape of index marking may vary

OUTLINE DIMENSIONS (Inch/mm)

A	B	C	D	E	F	G	wt
.079	.049	.033	.014	.012	.012	.026	grams
2.01	1.24	0.84	0.36	0.30	0.30	0.65	.008



CERAMIC

Power Splitter / Combiner

SCG-3-752+

Mini-Circuits

3 Way-0° 50Ω 4500 to 7500 MHz

TYPICAL PERFORMANCE DATA AND CHARTS

Frequency (MHz)	Total Loss ¹ (dB)			Amplitude Unbalance (dB)	Isolation (dB)			Phase Unbalance (deg.)	Return Loss (dB)			
	S-1	S-2	S-3		1-2	1-3	2-3		S	1	2	3
4500	5.96	5.84	5.91	0.12	13.78	14.30	13.75	2.77	8.50	29.80	17.44	31.74
4750	5.91	5.78	5.86	0.13	14.78	15.15	14.76	2.89	8.99	36.84	18.69	29.64
5000	5.86	5.72	5.82	0.15	15.96	16.14	15.95	2.95	9.51	34.52	20.01	25.68
5250	5.83	5.67	5.80	0.16	17.27	17.21	17.28	3.18	10.01	27.93	21.42	22.64
5500	5.77	5.60	5.76	0.17	18.88	18.49	18.90	3.40	10.67	24.45	22.98	20.62
5750	5.73	5.54	5.72	0.19	20.94	20.07	21.00	3.59	11.54	21.65	24.06	19.06
6000	5.68	5.47	5.68	0.21	23.70	22.04	23.79	3.85	12.72	19.75	24.97	17.65
6250	5.65	5.41	5.66	0.24	27.94	24.67	28.13	4.13	14.24	18.08	25.38	16.56
6500	5.63	5.38	5.65	0.27	35.49	27.81	36.13	4.38	15.87	16.65	24.67	15.56
6750	5.65	5.36	5.65	0.30	40.04	30.69	39.93	4.61	18.07	15.34	23.32	14.66
7000	5.70	5.37	5.69	0.33	29.04	29.26	28.83	4.85	19.29	14.08	21.59	13.81
7250	5.82	5.45	5.80	0.37	24.78	25.47	24.58	4.95	16.84	12.81	19.13	12.76
7500	6.03	5.61	5.97	0.42	22.01	22.30	21.80	5.11	13.58	11.54	16.71	11.67

1. Total Loss = Insertion Loss + 4.8dB splitter loss.

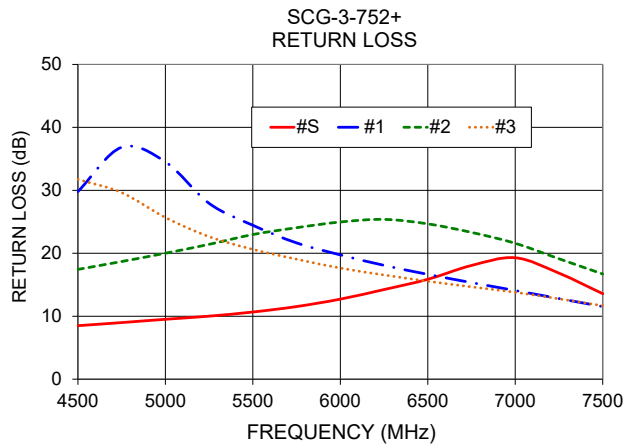
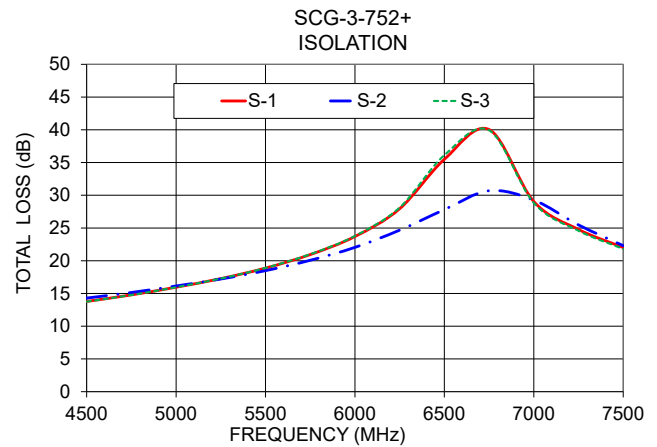
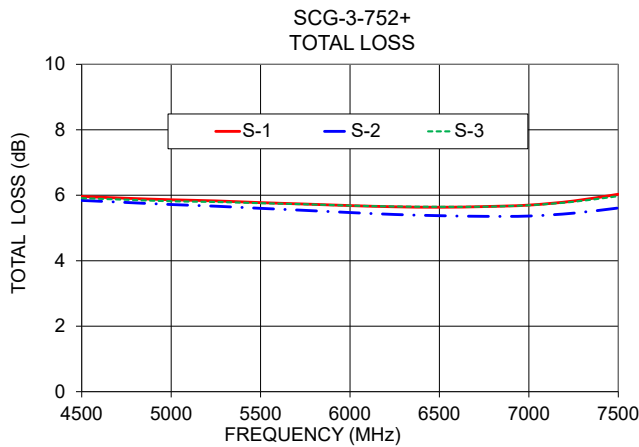

NOTES

- A. Performance and quality attributes and conditions not expressly stated in this specification document are intended to be excluded and do not form a part of this specification document.
- B. Electrical specifications and performance data contained in this specification document are based on Mini-Circuit's applicable established test performance criteria and measurement instructions.
- C. The parts covered by this specification document are subject to Mini-Circuits standard limited warranty and terms and conditions (collectively, "Standard Terms"); Purchasers of this part are entitled to the rights and benefits contained therein. For a full statement of the standard terms and the exclusive rights and remedies thereunder, please visit Mini-Circuits' website at www.minicircuits.com/terms/viewterm.html



3 Way-0° Power Splitter/Combiner

SCG-3-752+

Typical Performance Data

TEST CONDITIONS: Input Power = -10dBm @Temperature = +25°C

FREQ.	TOTAL LOSS ⁽¹⁾			AMP. UNBAL.	PHASE UNBAL.	ISOLATION			VSWR			
	(MHz)	(dB) S-1	(dB) S-2			(dB) S-3	(dB) 1-2	(dB) 1-3	(dB) 2-3	(:1)		
4500	5.96	5.84	5.91	0.12	2.77	13.78	14.30	13.75	2.20	1.07	1.31	1.05
4550	5.94	5.82	5.89	0.12	2.76	13.98	14.47	13.96	2.16	1.06	1.30	1.05
4600	5.95	5.82	5.89	0.13	2.83	14.17	14.63	14.14	2.17	1.05	1.29	1.05
4650	5.92	5.80	5.87	0.12	2.83	14.38	14.81	14.35	2.13	1.04	1.28	1.06
4700	5.93	5.79	5.87	0.13	2.85	14.58	14.98	14.55	2.13	1.04	1.27	1.06
4750	5.91	5.78	5.86	0.13	2.89	14.78	15.15	14.76	2.10	1.03	1.26	1.07
4800	5.90	5.76	5.85	0.14	2.89	15.03	15.37	15.01	2.08	1.02	1.25	1.07
4850	5.90	5.76	5.85	0.14	2.95	15.20	15.50	15.18	2.07	1.03	1.25	1.08
4900	5.88	5.74	5.83	0.14	2.90	15.49	15.75	15.47	2.04	1.03	1.24	1.09
4950	5.88	5.74	5.84	0.14	2.98	15.66	15.88	15.64	2.04	1.03	1.23	1.10
5000	5.86	5.72	5.82	0.15	2.95	15.96	16.14	15.95	2.00	1.04	1.22	1.11
5050	5.87	5.72	5.83	0.15	3.04	16.15	16.29	16.14	2.01	1.05	1.21	1.12
5100	5.84	5.70	5.81	0.15	3.04	16.47	16.56	16.47	1.97	1.06	1.21	1.13
5150	5.85	5.69	5.81	0.15	3.11	16.68	16.73	16.68	1.97	1.06	1.20	1.14
5200	5.83	5.67	5.79	0.15	3.13	17.02	17.02	17.02	1.93	1.07	1.19	1.15
5250	5.83	5.67	5.80	0.16	3.18	17.27	17.21	17.28	1.92	1.08	1.19	1.16
5300	5.81	5.65	5.78	0.16	3.22	17.58	17.46	17.59	1.90	1.09	1.18	1.17
5350	5.80	5.64	5.78	0.17	3.25	17.91	17.73	17.92	1.88	1.10	1.17	1.18
5400	5.79	5.63	5.77	0.16	3.30	18.18	17.94	18.20	1.87	1.11	1.16	1.18
5450	5.78	5.61	5.76	0.17	3.34	18.56	18.25	18.59	1.84	1.12	1.16	1.20
5500	5.77	5.60	5.76	0.17	3.40	18.88	18.49	18.90	1.83	1.13	1.15	1.21
5550	5.76	5.58	5.75	0.18	3.42	19.28	18.81	19.31	1.80	1.14	1.15	1.21
5600	5.76	5.58	5.75	0.18	3.47	19.62	19.06	19.65	1.79	1.15	1.15	1.23
5650	5.75	5.56	5.73	0.19	3.51	20.09	19.43	20.13	1.76	1.15	1.14	1.23
5700	5.74	5.55	5.73	0.19	3.57	20.50	19.74	20.54	1.74	1.17	1.13	1.24
5750	5.73	5.54	5.72	0.19	3.59	20.94	20.07	21.00	1.72	1.18	1.13	1.25
5800	5.72	5.52	5.71	0.20	3.67	21.42	20.42	21.47	1.70	1.19	1.13	1.26
5850	5.71	5.51	5.71	0.20	3.67	21.93	20.80	22.00	1.68	1.20	1.13	1.27
5900	5.70	5.50	5.70	0.21	3.76	22.50	21.20	22.57	1.65	1.21	1.12	1.28
5950	5.70	5.49	5.70	0.21	3.80	23.04	21.58	23.11	1.64	1.22	1.12	1.29
6000	5.68	5.47	5.68	0.21	3.85	23.70	22.04	23.79	1.60	1.23	1.12	1.30
6050	5.68	5.47	5.69	0.22	3.92	24.31	22.45	24.40	1.59	1.24	1.12	1.31
6100	5.67	5.45	5.68	0.23	3.96	25.04	22.94	25.17	1.56	1.25	1.12	1.32
6150	5.66	5.44	5.67	0.23	4.04	25.92	23.49	26.04	1.54	1.27	1.11	1.33
6200	5.66	5.43	5.67	0.24	4.05	26.68	23.97	26.83	1.52	1.28	1.12	1.34
6250	5.65	5.41	5.66	0.24	4.13	27.94	24.67	28.13	1.48	1.28	1.11	1.35
6300	5.65	5.41	5.66	0.25	4.16	28.69	25.07	28.90	1.48	1.30	1.12	1.36
6350	5.64	5.39	5.65	0.26	4.25	30.39	25.93	30.66	1.43	1.31	1.12	1.37
6400	5.64	5.39	5.65	0.26	4.28	31.48	26.38	31.80	1.43	1.33	1.12	1.38
6450	5.64	5.38	5.64	0.26	4.34	33.74	27.28	34.18	1.39	1.33	1.12	1.39
6500	5.63	5.38	5.65	0.27	4.38	35.49	27.81	36.13	1.38	1.34	1.12	1.40
6550	5.63	5.36	5.64	0.27	4.44	38.93	28.67	40.01	1.35	1.36	1.13	1.41
6600	5.64	5.36	5.65	0.29	4.47	42.29	29.29	44.50	1.34	1.37	1.13	1.42
6650	5.64	5.36	5.64	0.29	4.52	46.24	29.97	50.12	1.31	1.39	1.13	1.43
6700	5.64	5.36	5.65	0.30	4.56	43.12	30.62	43.75	1.30	1.40	1.14	1.44
6750	5.65	5.36	5.65	0.30	4.61	40.04	30.69	39.93	1.29	1.41	1.15	1.45
6800	5.65	5.35	5.66	0.31	4.65	35.86	31.22	35.69	1.26	1.42	1.15	1.46
6850	5.67	5.36	5.66	0.31	4.69	34.29	30.67	34.00	1.26	1.44	1.16	1.48
6900	5.67	5.35	5.67	0.32	4.77	31.76	30.61	31.54	1.25	1.45	1.16	1.48
6950	5.69	5.37	5.68	0.33	4.79	30.80	29.76	30.56	1.25	1.47	1.18	1.51
7000	5.70	5.37	5.69	0.33	4.85	29.04	29.26	28.83	1.24	1.49	1.18	1.51
7050	5.73	5.39	5.71	0.34	4.83	28.25	28.35	28.04	1.26	1.51	1.20	1.54
7100	5.74	5.39	5.73	0.35	4.92	27.02	27.69	26.81	1.26	1.52	1.20	1.54
7150	5.77	5.42	5.75	0.36	4.93	26.29	26.83	26.10	1.29	1.55	1.22	1.57
7200	5.80	5.43	5.77	0.37	4.96	25.44	26.12	25.25	1.30	1.57	1.23	1.58
7250	5.82	5.45	5.80	0.37	4.95	24.78	25.47	24.58	1.34	1.59	1.25	1.60
7300	5.86	5.47	5.82	0.39	5.02	24.10	24.69	23.90	1.36	1.62	1.26	1.62
7350	5.89	5.51	5.86	0.39	5.04	23.49	24.16	23.30	1.40	1.64	1.28	1.64
7400	5.94	5.53	5.89	0.40	5.07	22.96	23.41	22.76	1.44	1.67	1.30	1.66
7450	5.97	5.57	5.94	0.41	5.10	22.41	22.97	22.22	1.48	1.69	1.32	1.68
7500	6.03	5.61	5.97	0.42	5.11	22.01	22.30	21.80	1.53	1.72	1.34	1.71

⁽¹⁾ Total Loss = Insertion Loss + 4.8dB Splitter Loss

Typical Performance Curves

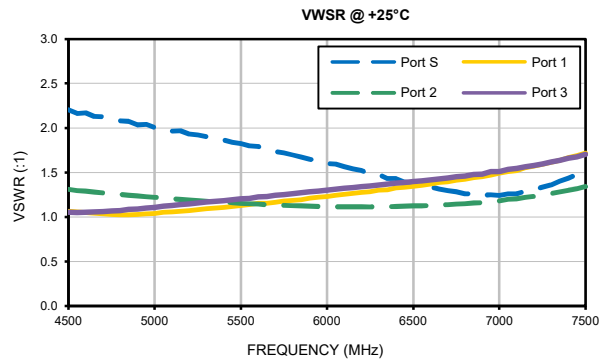
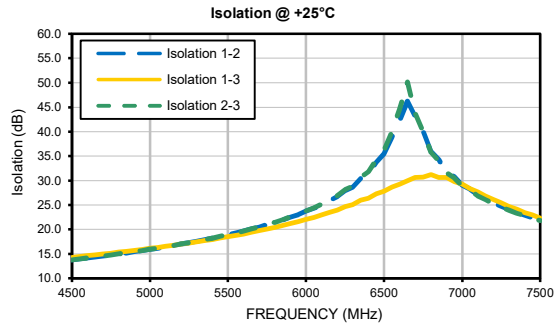
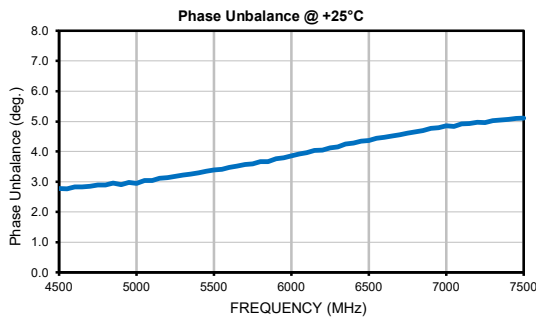
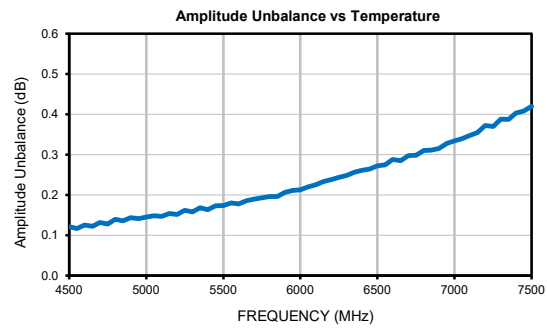
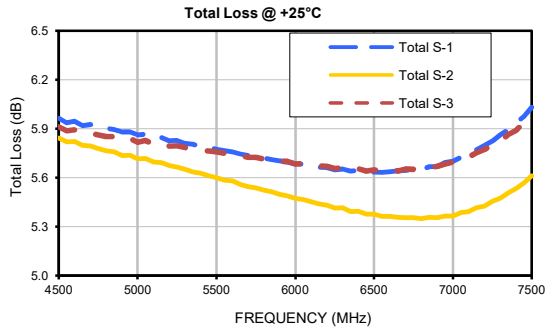

Outline Dimensions

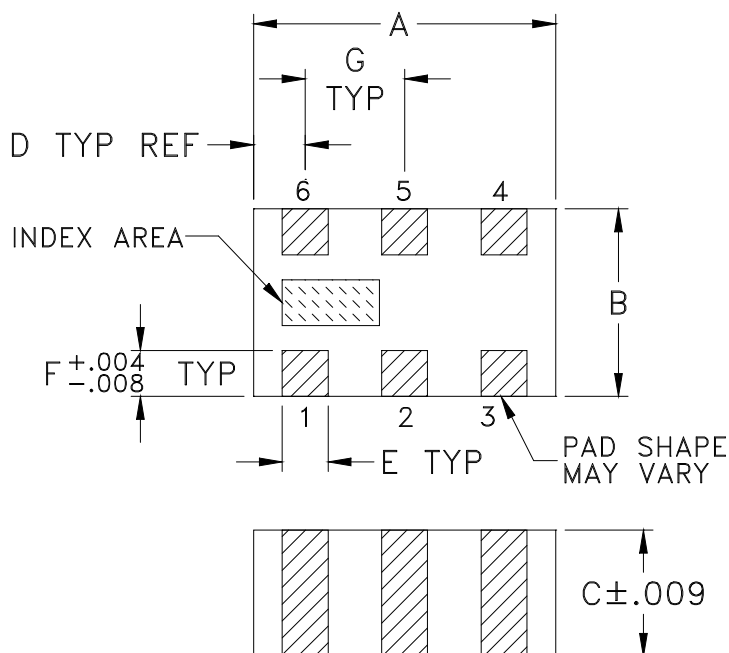

PCB Land Pattern

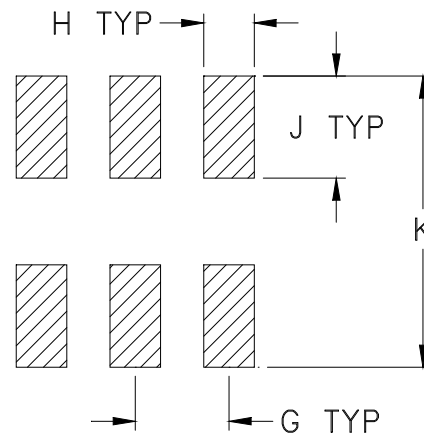

Suggested Layout,
Tolerance to be within ± 0.002

CASE #	A	B	C	D	E	F	G	H	J	K	WT. GRAM
GE0805C-1	.079 (2.00)	.049 (1.25)	.033 (0.84)	.014 (0.35)	.012 (0.30)	.012 (0.30)	.026 (0.65)	.014 (0.35)	.039 (1.00)	.110 (2.80)	.008

Dimensions are in inches (mm). Tolerances: 2Pl. $\pm .01$; 3 Pl. $\pm .005$

Notes:

- Open style, ceramic base.
- Termination finish: For RoHS Case Styles: Tin plate over Nickel plate. All models, (+) suffix.
For RoHS-5 Case Style: Tin-lead plate. All models, no (+) suffix.



P.O. Box 350166, Brooklyn, New York 11235-0003 (718) 934-4500 Fax (718) 332-4661 For detailed performance specs & shopping online see Mini-Circuits web site



The Design Engineers Search Engine Provides ACTUAL Data Instantly From MINI-CIRCUITS At: www.minicircuits.com

RF/IF MICROWAVE COMPONENTS

Tape & Reel Packaging TR-F74

DEVICE ORIENTATION IN T&R

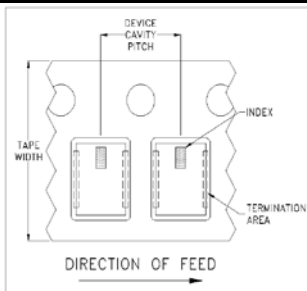

ILLUSTRATION 1

Applicable Case Styles

GE0805C-1
 GE0805C-1AP
 JV1210C-1
 GU2939

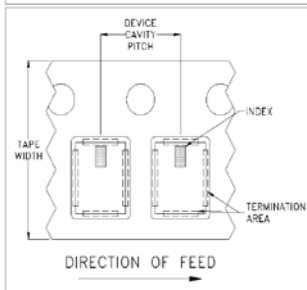

ILLUSTRATION 2

Applicable Case Styles

JV1210C
 JV1210C-2
 JV1210C-3
 JV1210C-4
 JV1210C-5
 JV1210C-6
 JV1210C-11

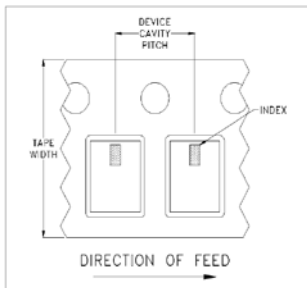

ILLUSTRATION 3

Applicable Case Styles

JC0603C-8
 JV1210C-7
 JV1210C-8
 JV1210C-9
 JV1210C-10
 JV1210C-13
 GE0805C-13

Tape Width, mm	Device Cavity Pitch, mm	Real Size, inches	Devices per Reel	
8	4	7	Small quantity standards (see note)	20
				50
				100
				200
				500
			Standard	1000
				2000
			4000	

Note: Small reel availability varies by model. Refer to pricing and availability on individual model dashboard.

Mini-Circuits carrier tape materials provide protection from ESD (Electro-Static Discharge) during handling and transportation. Tapes are static dissipative and comply with industry standards EIA-481/EIA-541.

Go to: www.minicircuits.com/pages/pdfs/tape.pdf



INTERNET <http://www.minicircuits.com>

P.O. Box 350166, Brooklyn, New York 11235-0003 (718) 934-4500 Fax (718) 332-4661

Distribution Centers NORTH AMERICA 800-654-7949 • 417-335-5935 • Fax 417-335-5945 • EUROPE 44-1252-832600 • Fax 44-1252-837010

Mini-Circuits ISO 9001 & ISO 14001 Certified

THIRD ANGLE PROJECTION

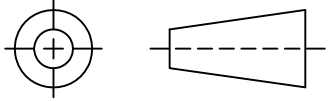

REVISIONS

REV	ECN No.	DESCRIPTION	DATE	DR	AUTH
OR	M173097	NEW RELEASE	03/12/19	ITG	SL

SUGGESTED MOUNTING CONFIGURATION
FOR GE0805C-1 CASE STYLE, "06SP17" PIN CODE

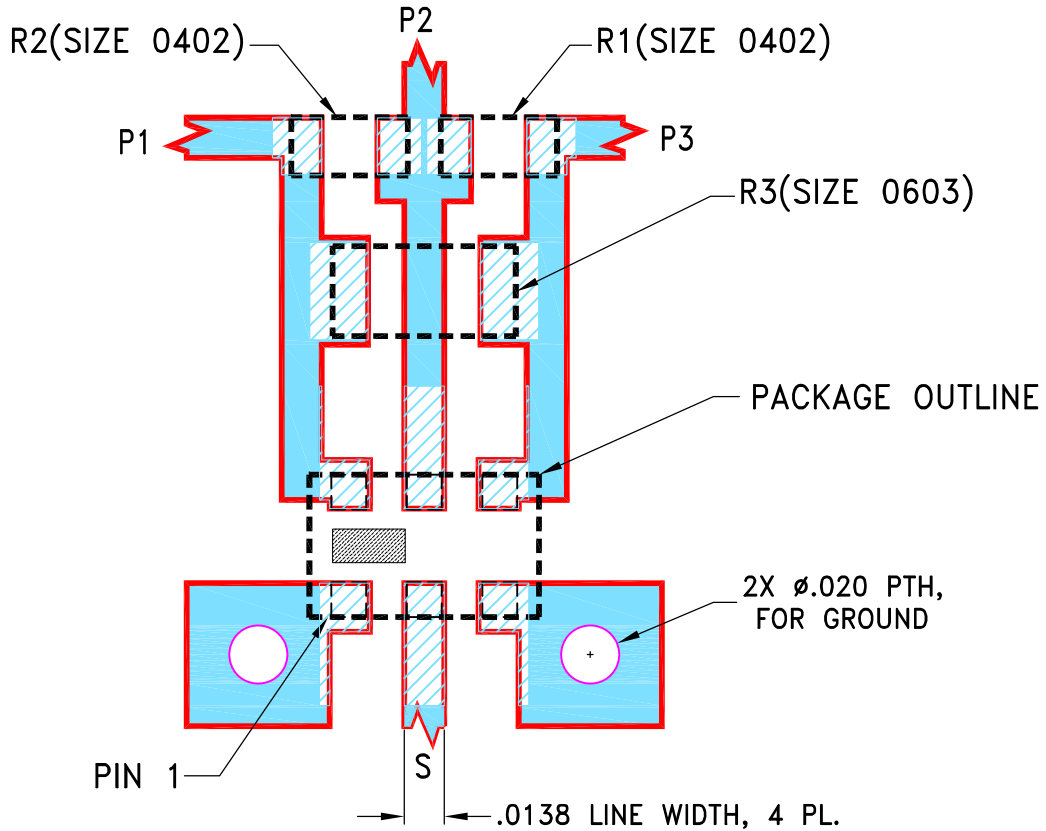

NOTES:

1. LINE WIDTH IS SHOWN FOR ROGERS R04350B WITH DIELECTRIC THICKNESS $.0066 \pm .0007$. COPPER: 1/2 OZ. EACH SIDE. FOR OTHER MATERIALS LINE WIDTH MAY NEED TO BE MODIFIED.
2. UNIT FOOT PRINT IS OPTIMIZED FOR PERFORMANCE AND IS DIFFERENT FROM CASE STYLE GE0805C-1 RECOMMENDATIONS.
3. CHIP COMPONENT FOOT PRINT IS SHOWN FOR REFERENCE. FOR COMPONENT VALUE REFER TO TB-1018+.
4. BOTTOM SIDE OF THE PCB IS CONTINUOUS GROUND PLANE.



DENOTES PCB COPPER LAYOUT WITH SMOBC (SOLDER MASK OVER BARE COPPER).

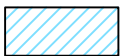

DENOTES COPPER LAND PATTERN FREE OF SOLDER MASK.

UNLESS OTHERWISE SPECIFIED	INITIALS	DATE
DRAWN	ITG	03/06/19
CHECKED	GF	03/07/19
APPROVED	SL	03/12/19



Mini-Circuits®

13 Neptune Avenue
Brooklyn NY 11235

PL, 06SP17, GE0805C-1, TB-1018+

Mini-Circuits®
 THIS DOCUMENT AND ITS CONTENTS ARE THE PROPERTY OF MINI-CIRCUITS. EXCEPT FOR USE EXPRESSLY GRANTED, IN WRITING, TO ITS VENDORS, VENDEE AND THE UNITED STATES GOVERNMENT, MINI-CIRCUITS RESERVES ALL PROPRIETARY DESIGN, USE, MANUFACTURING AND REPRODUCTION RIGHTS THERETO. THESE CONTENTS SHALL NOT BE USED, DUPLICATED OR DISCLOSED TO ANY OUTSIDE PARTY, IN WHOLE OR IN PART, WITHOUT WRITTEN PERMISSION OF MINI-CIRCUITS.

SIZE	CODE IDENT	DRAWING NO:	REV:
A	15542	98-PL-621	OR
FILE:	98PL621	SCALE:	15:1
		SHEET:	1 OF 1

Evaluation Board and Circuit

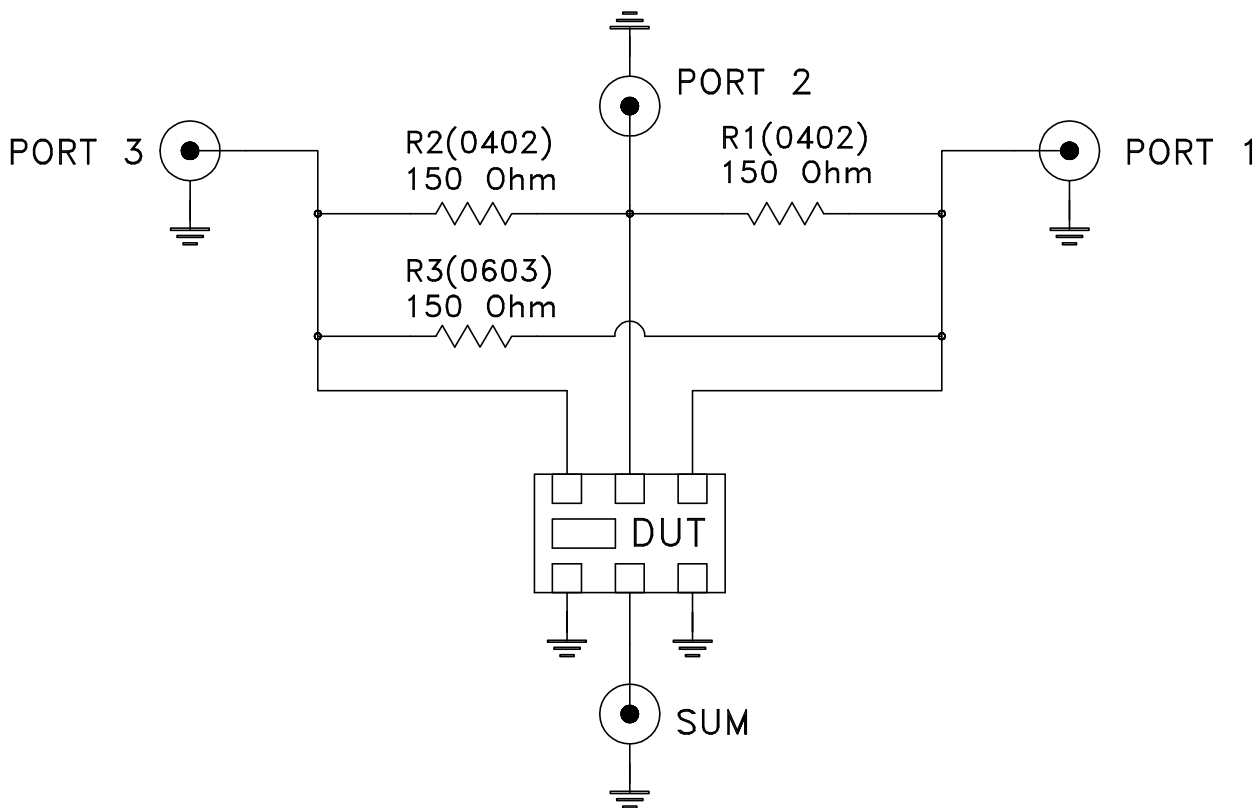
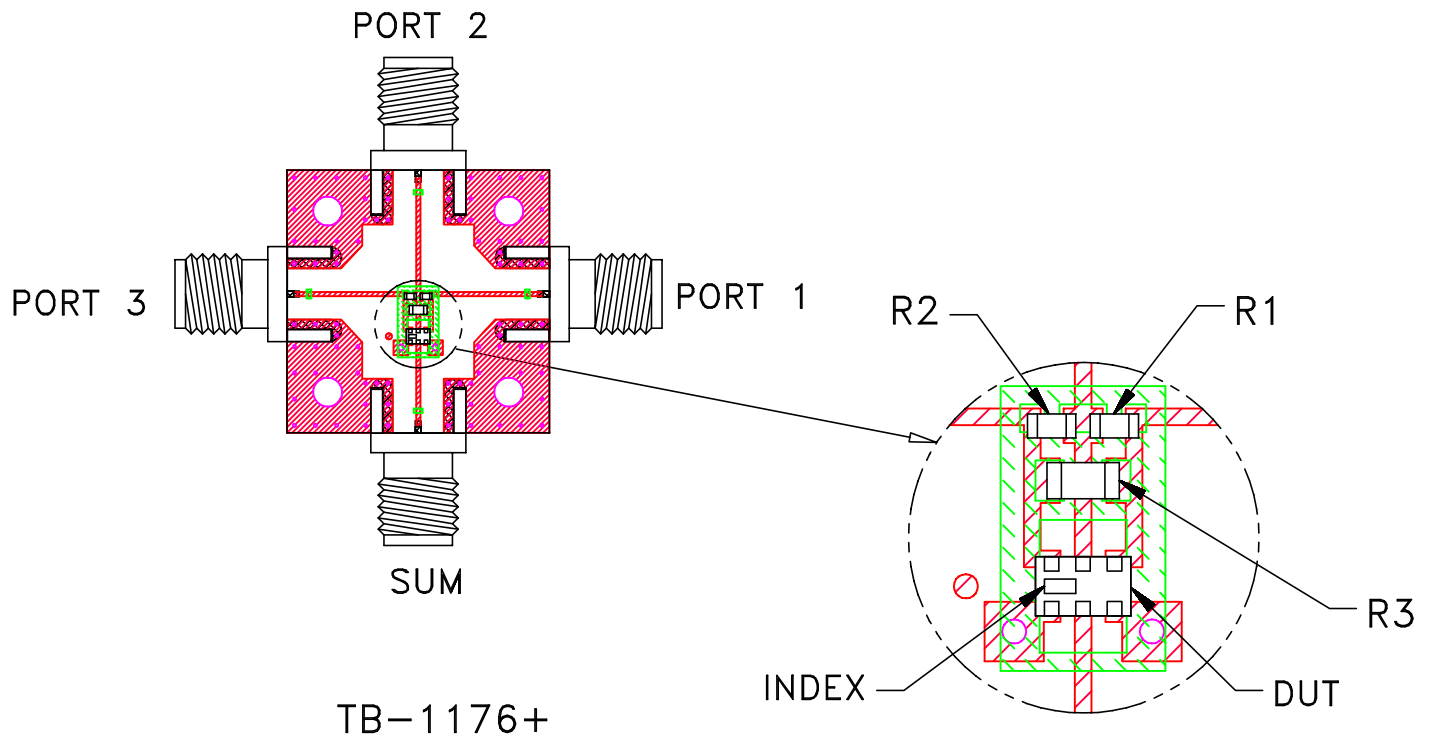

Schematic Diagram

Notes:

1. 50 Ohm SMA Female connectors.
2. PCB Material: R04350 or equivalent,
Dielectric Constant=3.5, Thickness=.0066 inch.

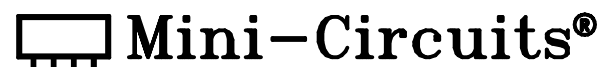



All Mini-Circuits products are manufactured under exacting quality assurance and control standards, and are capable of meeting published specifications after being subjected to any or all of the following physical and environmental test.

Specification	Test/Inspection Condition	Reference/Spec
Operating Temperature	-55° to 125° C Ambient Environment	Individual Model Data Sheet
Storage Temperature	-55° to 125° C Ambient Environment	Individual Model Data Sheet
Humidity	90 to 95% RH, 240 hours, 50°C	MIL-STD-202, Method 103, Condition A, Except 50°C and end-point electrical test done within 12 hours
Solder Reflow Heat	Sn-Pb Eutectic Process: 225°C peak Pb-Free Process: 250°C peak	J-STD-020C, Table 4-1, 4-2 and 5-2; Figure 5-1
Solderability	10X Magnification	J-STD-002, Para 4.2.5, Test S, 95% Coverage
Vibration (High Frequency)	20g peak, 10-2000 Hz, 12 times in each of three perpendicular directions (total 36)	MIL-STD-202, Method 204, Condition D
Mechanical Shock	50g, 11 ms, 1/2-sine, 18 shocks: 3 each direction, each of 3 axes	MIL-STD-202, Method 213, Condition A