



CERAMIC

# Power Splitter/Combiner

# SCG-2-322+

Mini-Circuits

2 Way-0° 50Ω 1800 to 3200 MHz

## FEATURES

- Isolation resistor, external 100 ohms
- Low insertion loss, 0.7 dB typ.
- Excellent amplitude unbalance, 0.1 dB typ.
- Excellent phase unbalance, 1.5 deg. typ.
- High isolation, 15 dB typ.
- ESD non-sensitive
- Temperature stable LTCC technology
- Wrap around terminations for excellent solderability
- Low cost



Generic photo used for illustration purposes only  
CASE STYLE: GE0805C-1

**+RoHS Compliant**  
The +Suffix identifies RoHS Compliance.  
See our website for methodologies and qualifications

## APPLICATIONS

- ISM
- WLAN

## ELECTRICAL SPECIFICATIONS AT 25°C

Parameter	Frequency (MHz)	Min.	Typ.	Max.	Unit
Frequency Range		1800		3200	MHz
Insertion Loss, above 3.0 dB	1800 - 3200	—	0.7	1.3	dB
Isolation	1800 - 3200	13	15	—	dB
Phase Unbalance	1800 - 3200	—	1.5	4.0	Degree
Amplitude Unbalance	1800 - 3200	—	0.1	0.3	dB
Return Loss (Input)	1800 - 3200	—	12	—	dB
Return Loss (Output)	1800 - 3200	—	15	—	dB

## MAXIMUM RATINGS

Parameter	Ratings
Operating Temperature	-55°C to 100°C
Storage Temperature	-55°C to 100°C
Power Input (as a splitter)	2W* max.

\* Derate linearly to 0.7W at 100°C ambient, power input as combiner is limited by rating of external resistor 100Ω resistor. Permanent damage may occur if any of these limits are exceeded.

## ELECTRICAL SCHEMATIC

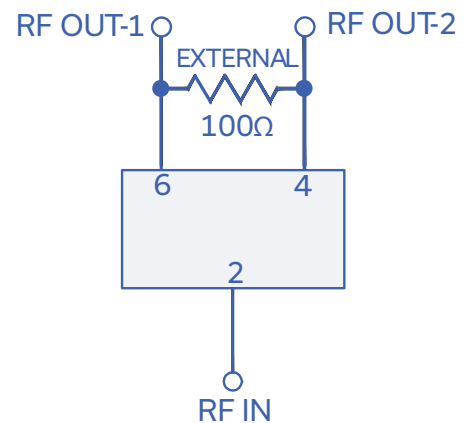



CERAMIC

# Power Splitter/Combiner

# SCG-2-322+

Mini-Circuits

2 Way-0° 50Ω 1800 to 3200 MHz

### PAD CONNECTIONS

SUM PORT	2
PORT 1	6
PORT 2	4
GROUND	1,3,5
PORT 1-2	resistor external 100 ohms

PRODUCT MARKING: SJ

DEMO BOARD MCL P/N: TB-1043+  
SUGGESTED PCB LAYOUT (PL-560)

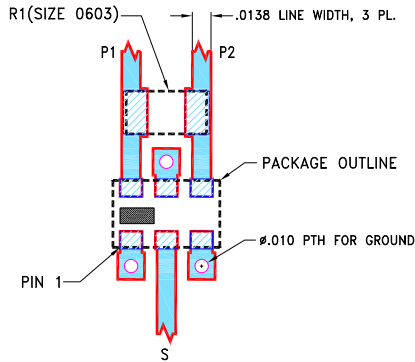

#### NOTES:

1. LINE WIDTH IS SHOWN FOR ROGERS RO4350B WITH DIELECTRIC THICKNESS .0066±.0007. COPPER: 1/2 OZ. EACH SIDE. FOR OTHER MATERIALS LINE WIDTH MAY NEED TO BE MODIFIED.
  2. UNIT FOOT PRINT IS OPTIMIZED FOR PERFORMANCE AND IS DIFFERENT FROM CASE STYLE GE0805C-1 RECOMMENDATIONS.
  3. CHIP COMPONENT FOOT PRINT IS SHOWN FOR REFERENCE. FOR COMPONENT VALUE REFER TO TB-1043+.
  4. BOTTOM SIDE OF THE PCB IS CONTINUOUS GROUND PLANE.
- DENOTES PCB COPPER LAYOUT WITH SMOBC (SOLDER MASK OVER BARE COPPER).
- DENOTES COPPER LAND PATTERN FREE OF SOLDER MASK.

### OUTLINE DRAWING

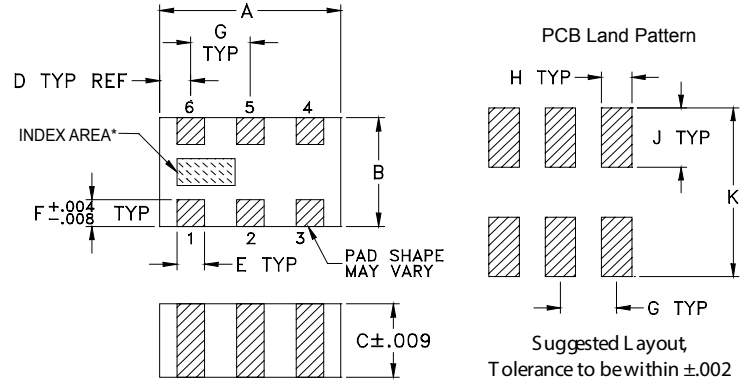

\*Shape of index marking may vary

### OUTLINE DIMENSIONS (Inches/mm)

A	B	C	D	E	F
.079	.049	.033	.014	.012	.012
2.01	1.24	0.84	0.36	0.30	0.30
G	H	J	K		wt
.026	.014	.039	.110		grams
0.66	0.36	1.00	2.80		.008

TAPE & REEL INFORMATION: F74



CERAMIC

# Power Splitter/Combiner

## SCG-2-322+

Mini-Circuits

2 Way-0° 50Ω 1800 to 3200 MHz

### TYPICAL PERFORMANCE DATA

Frequency (MHz)	Total Loss <sup>1</sup> (dB)		Amplitude Unbalance (dB)	Isolation (dB)	Phase Unbalance (deg.)	Return Loss (dB)		
	S-1	S-2				S	1	2
1800	3.50	3.47	0.03	15.73	0.44	14.85	32.69	35.91
1900	3.47	3.44	0.03	17.10	0.46	15.89	30.46	33.61
2000	3.45	3.42	0.03	18.69	0.49	17.27	28.52	31.28
2100	3.44	3.41	0.03	20.49	0.51	18.57	26.70	29.21
2200	3.44	3.40	0.04	22.76	0.56	19.85	25.40	27.72
2300	3.45	3.41	0.04	25.53	0.58	20.85	24.17	26.43
2400	3.47	3.42	0.04	28.36	0.63	21.10	22.94	25.00
2500	3.50	3.45	0.05	28.63	0.67	20.34	21.64	23.51
2600	3.54	3.48	0.05	26.04	0.73	18.73	20.31	22.01
2700	3.58	3.53	0.06	23.78	0.79	17.39	19.17	20.83
2800	3.63	3.57	0.06	21.94	0.85	16.28	18.16	19.80
2900	3.69	3.62	0.07	20.47	0.91	15.12	17.13	18.72
3000	3.75	3.67	0.08	19.15	0.97	14.05	16.17	17.69
3100	3.80	3.72	0.08	18.08	1.07	13.16	15.24	16.69
3200	3.86	3.77	0.08	17.25	1.18	12.47	14.41	15.83

1. Total Loss = Insertion Loss + 3dB splitter loss.

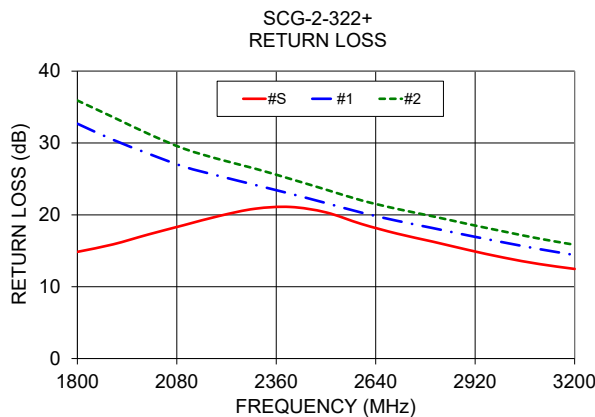
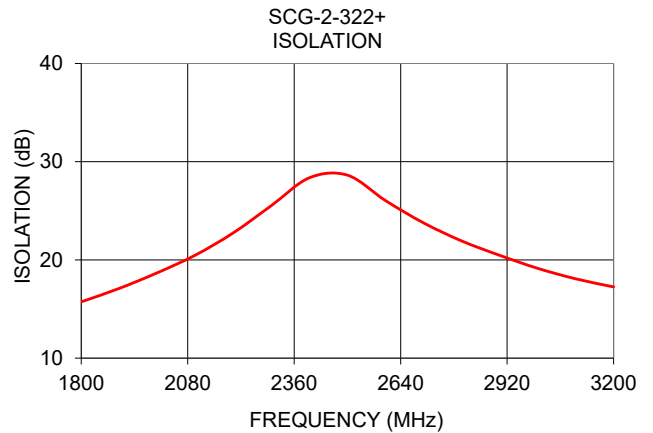
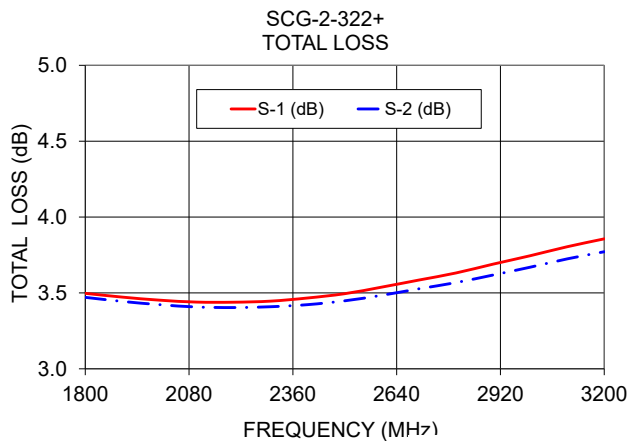

- NOTES**
- A. Performance and quality attributes and conditions not expressly stated in this specification document are intended to be excluded and do not form a part of this specification document.
  - B. Electrical specifications and performance data contained in this specification document are based on Mini-Circuit's applicable established test performance criteria and measurement instructions.
  - C. The parts covered by this specification document are subject to Mini-Circuits standard limited warranty and terms and conditions (collectively, "Standard Terms"); Purchasers of this part are entitled to the rights and benefits contained therein. For a full statement of the standard. Terms and the exclusive rights and remedies thereunder, please visit Mini-Circuits' website at [www.minicircuits.com/terms/viewterm.html](http://www.minicircuits.com/terms/viewterm.html)



# 2 Way-0° Power Splitter/Combiner

# SCG-2-322+

## Typical Performance Data

FREQUENCY (MHz)	TOTAL LOSS <sup>1</sup> (dB)		AMPLITUDE UNBALANCE (dB)	ISOLATION (dB)	PHASE UNBALANCE (deg.)	FREQUENCY (MHz)	VSWR (:1)		
	S-1	S-2					S	1	2
1500	3.57	3.54	0.03	12.43	0.37	1500	1.59	1.03	1.04
1600	3.55	3.52	0.02	13.44	0.39	1600	1.54	1.03	1.03
1700	3.52	3.50	0.03	14.54	0.41	1700	1.49	1.03	1.02
1800	3.50	3.47	0.03	15.73	0.44	1800	1.44	1.05	1.03
1850	3.48	3.45	0.03	16.40	0.45	1850	1.41	1.05	1.04
1900	3.47	3.44	0.03	17.10	0.46	1900	1.38	1.06	1.04
1950	3.46	3.43	0.03	17.91	0.47	1950	1.34	1.07	1.05
2000	3.45	3.42	0.03	18.69	0.49	2000	1.32	1.08	1.06
2050	3.45	3.42	0.03	19.59	0.50	2050	1.29	1.09	1.06
2110	3.44	3.41	0.03	20.67	0.52	2110	1.27	1.10	1.07
2160	3.44	3.41	0.04	21.74	0.52	2160	1.25	1.11	1.08
2210	3.44	3.41	0.03	23.00	0.56	2210	1.22	1.12	1.09
2260	3.45	3.41	0.04	24.26	0.58	2260	1.21	1.12	1.09
2310	3.45	3.41	0.04	25.84	0.58	2310	1.20	1.13	1.10
2370	3.46	3.42	0.04	27.49	0.62	2370	1.20	1.15	1.11
2420	3.47	3.43	0.04	28.84	0.65	2420	1.19	1.16	1.12
2470	3.49	3.44	0.04	28.95	0.65	2470	1.20	1.17	1.14
2520	3.51	3.46	0.05	28.33	0.69	2520	1.22	1.19	1.15
2570	3.53	3.48	0.05	26.93	0.71	2570	1.24	1.20	1.16
2620	3.55	3.50	0.05	25.63	0.75	2620	1.27	1.22	1.18
2680	3.57	3.51	0.06	24.31	0.78	2680	1.30	1.24	1.19
2730	3.61	3.55	0.06	23.15	0.80	2730	1.33	1.26	1.21
2780	3.62	3.56	0.06	22.33	0.84	2780	1.35	1.28	1.22
2830	3.65	3.59	0.07	21.37	0.86	2830	1.38	1.29	1.24
2880	3.68	3.61	0.07	20.69	0.89	2880	1.42	1.32	1.26
2940	3.71	3.63	0.07	19.85	0.94	2940	1.45	1.34	1.28
2990	3.74	3.66	0.07	19.23	0.97	2990	1.49	1.36	1.30
3040	3.76	3.68	0.08	18.75	1.00	3040	1.51	1.38	1.31
3090	3.80	3.72	0.08	18.16	1.06	3090	1.55	1.41	1.34
3140	3.83	3.74	0.08	17.82	1.11	3140	1.59	1.44	1.36
3200	3.86	3.77	0.08	17.25	1.18	3200	1.62	1.47	1.39
3300	3.93	3.84	0.09	16.54	1.31	3300	1.71	1.53	1.44
3470	4.09	4.00	0.09	15.46	1.55	3470	1.89	1.65	1.54

<sup>1</sup>Total Loss = Insertion Loss + 3dB Splitter Loss



## Typical Performance Curves

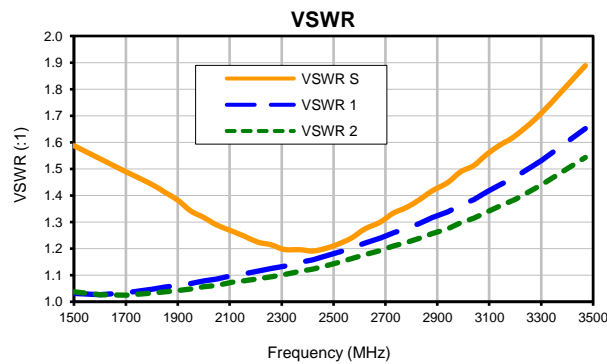
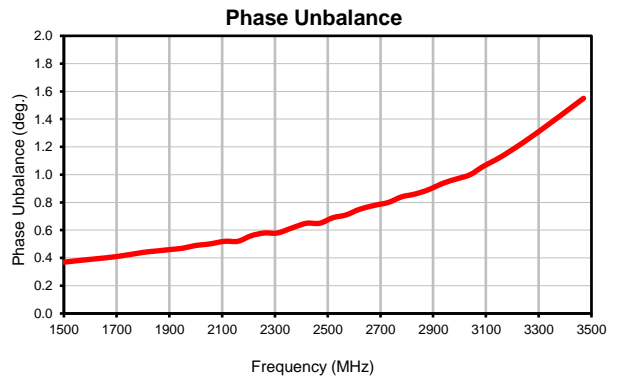
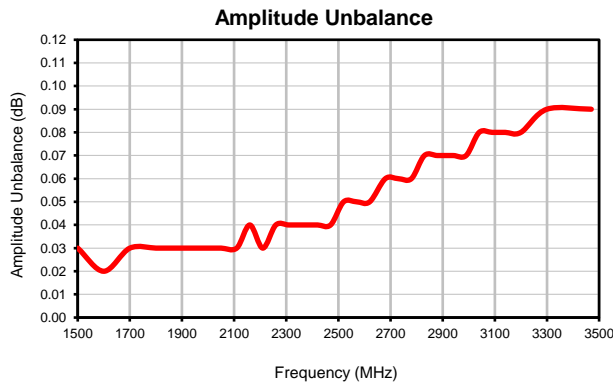
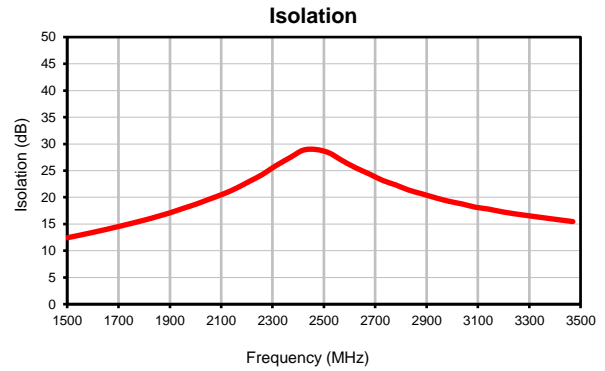

### Outline Dimensions

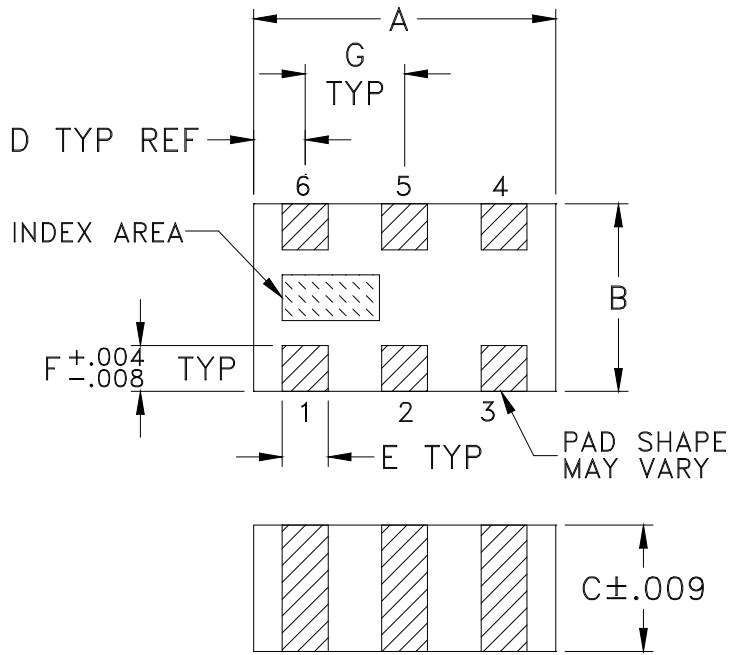

### PCB Land Pattern

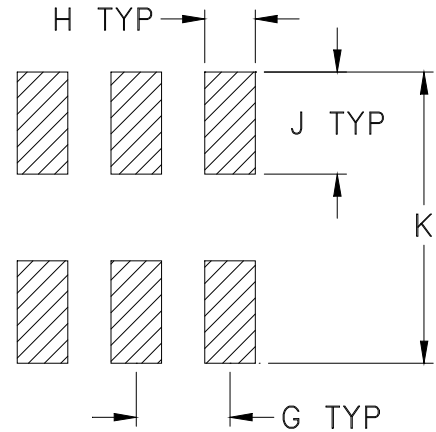

Suggested Layout,  
Tolerance to be within  $\pm 0.002$

CASE #	A	B	C	D	E	F	G	H	J	K	WT. GRAM
GE0805C-1	.079 (2.00)	.049 (1.25)	.033 (0.84)	.014 (0.35)	.012 (0.30)	.012 (0.30)	.026 (0.65)	.014 (0.35)	.039 (1.00)	.110 (2.80)	.008

Dimensions are in inches (mm). Tolerances: 2Pl.  $\pm .01$ ; 3 Pl.  $\pm .005$

### Notes:

- Open style, ceramic base.
- Termination finish: For RoHS Case Styles: Tin plate over Nickel plate. All models, (+) suffix.  
For RoHS-5 Case Style: Tin-lead plate. All models, no (+) suffix.



P.O. Box 350166, Brooklyn, New York 11235-0003 (718) 934-4500 Fax (718) 332-4661 For detailed performance specs & shopping online see Mini-Circuits web site



The Design Engineers Search Engine Provides ACTUAL Data Instantly From MINI-CIRCUITS At: [www.minicircuits.com](http://www.minicircuits.com)

RF/IF MICROWAVE COMPONENTS

# Tape & Reel Packaging TR-F74

## DEVICE ORIENTATION IN T&R

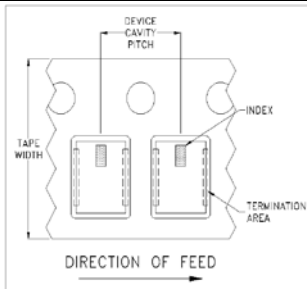

**ILLUSTRATION 1**

### Applicable Case Styles

GE0805C-1  
 GE0805C-1AP  
 JV1210C-1  
 GU2939

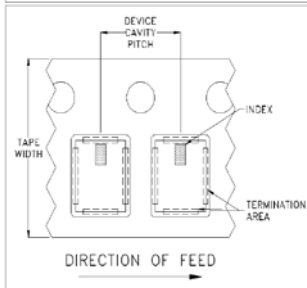

**ILLUSTRATION 2**

### Applicable Case Styles

JV1210C  
 JV1210C-2  
 JV1210C-3  
 JV1210C-4  
 JV1210C-5  
 JV1210C-6  
 JV1210C-11

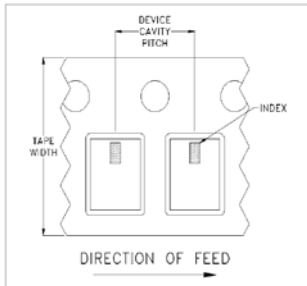

**ILLUSTRATION 3**

### Applicable Case Styles

JC0603C-8  
 JV1210C-7  
 JV1210C-8  
 JV1210C-9  
 JV1210C-10  
 JV1210C-13  
 GE0805C-13

Tape Width, mm	Device Cavity Pitch, mm	Real Size, inches	Devices per Reel	
8	4	7	Small quantity standards (see note)	20
				50
				100
				200
				500
			Standard	1000
				2000
			4000	

Note: Small reel availability varies by model. Refer to pricing and availability on individual model dashboard.

Mini-Circuits carrier tape materials provide protection from ESD (Electro-Static Discharge) during handling and transportation. Tapes are static dissipative and comply with industry standards EIA-481/EIA-541.

Go to: [www.minicircuits.com/pages/pdfs/tape.pdf](http://www.minicircuits.com/pages/pdfs/tape.pdf)



Distribution Centers NORTH AMERICA 800-654-7949 • 417-335-5935 • Fax 417-335-5945 • EUROPE 44-1252-832600 • Fax 44-1252-837010

Mini-Circuits ISO 9001 & ISO 14001 Certified

INTERNET <http://www.minicircuits.com>

P.O. Box 350166, Brooklyn, New York 11235-0003 (718) 934-4500 Fax (718) 332-4661

THIRD ANGLE PROJECTION

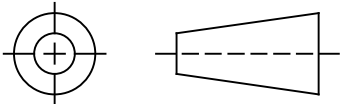

REVISIONS

REV	ECN No.	DESCRIPTION	DATE	DR	AUTH
OR	M172101	NEW RELEASE	02/20/19	ITG	SL
A	ECO-004368	ADDED DIMENSIONS IN [MM]		GF	

SUGGESTED MOUNTING CONFIGURATION  
FOR GE0805C-1 CASE STYLE, "06SP17" PIN CODE

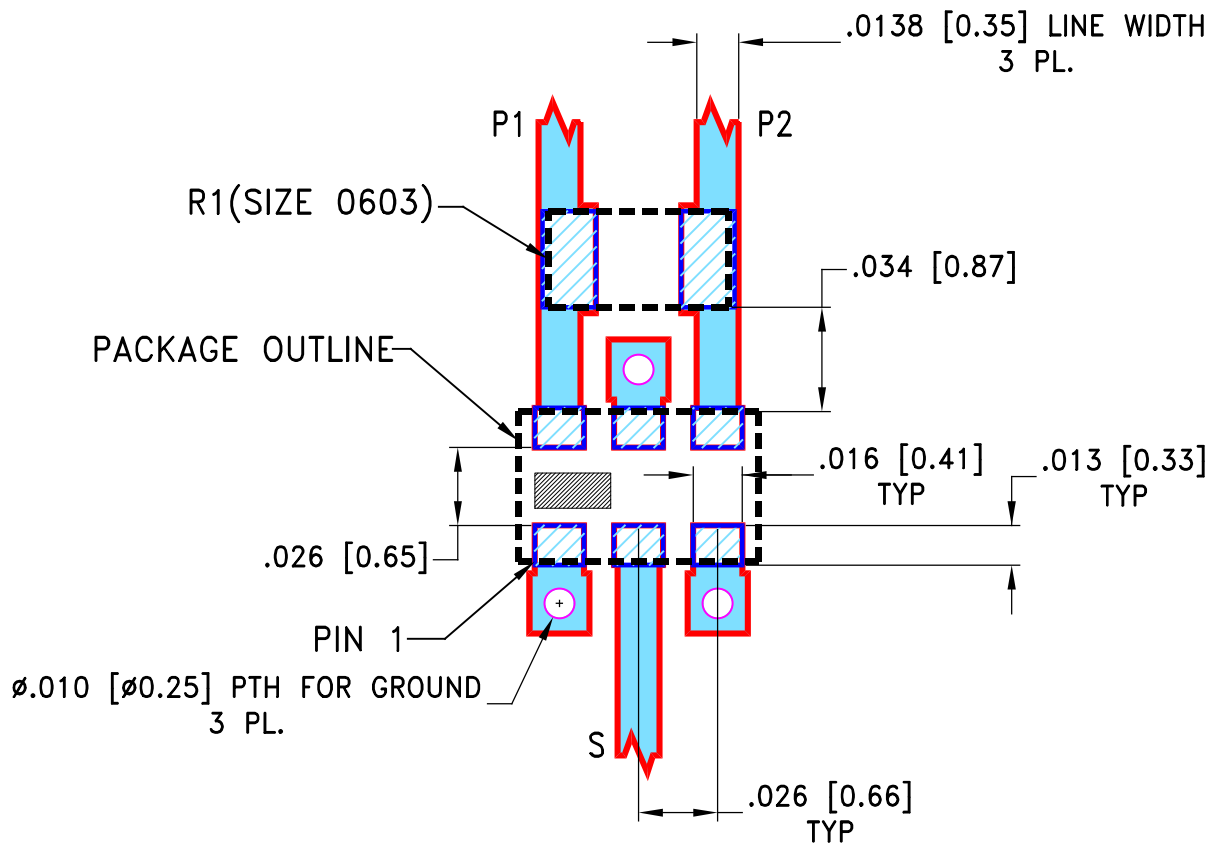

NOTES:

1. LINE WIDTH IS SHOWN FOR ROGERS R04350B WITH DIELECTRIC THICKNESS  $.0066 \pm .0007$  [.168 ± .018]. COPPER: 1/2 OZ. EACH SIDE. FOR OTHER MATERIALS LINE WIDTH MAY NEED TO BE MODIFIED.
2. UNIT FOOT PRINT IS OPTIMIZED FOR PERFORMANCE AND IS DIFFERENT FROM CASE STYLE GE0805C-1 RECOMMENDATIONS.
3. CHIP COMPONENT FOOT PRINT IS SHOWN FOR REFERENCE. FOR COMPONENT VALUE REFER TO TB-1043+.
4. BOTTOM SIDE OF THE PCB IS CONTINUOUS GROUND PLANE.



DENOTES PCB COPPER LAYOUT WITH SMOBC (SOLDER MASK OVER BARE COPPER).

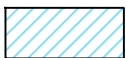

DENOTES COPPER LAND PATTERN FREE OF SOLDER MASK.

UNLESS OTHERWISE SPECIFIED	INITIALS	DATE
DIMENSIONS ARE IN INCHES[MM]	DRAWN ITG	01/21/19
TOLERANCES ON:	CHECKED GF	01/22/19
2 PL DECIMALS ±	APPROVED SL	02/20/19
3 PL DECIMALS ± .005		
ANGLES ±		
FRACTIONS ±		



**Mini-Circuits®** 13 Neptune Avenue  
 Brooklyn NY 11235

PL, 06SP17, GE0805C-1, TB-1043+

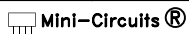

THIS DOCUMENT AND ITS CONTENTS ARE THE PROPERTY OF MINI-CIRCUITS. EXCEPT FOR USE EXPRESSLY GRANTED, IN WRITING, TO ITS VENDORS, VENDEE AND THE UNITED STATES GOVERNMENT, MINI-CIRCUITS RESERVES ALL PROPRIETARY DESIGN, USE, MANUFACTURING AND REPRODUCTION RIGHTS THERETO. THESE CONTENTS SHALL NOT BE USED, DUPLICATED OR DISCLOSED TO ANY OUTSIDE PARTY, IN WHOLE OR IN PART, WITHOUT WRITTEN PERMISSION OF MINI-CIRCUITS.

SIZE	CODE IDENT	DRAWING NO:	REV:
A	15542	98-PL-560	A
FILE:	98PL560	SCALE: 15:1	SHEET: 1 OF 1



# Evaluation Board and Circuit

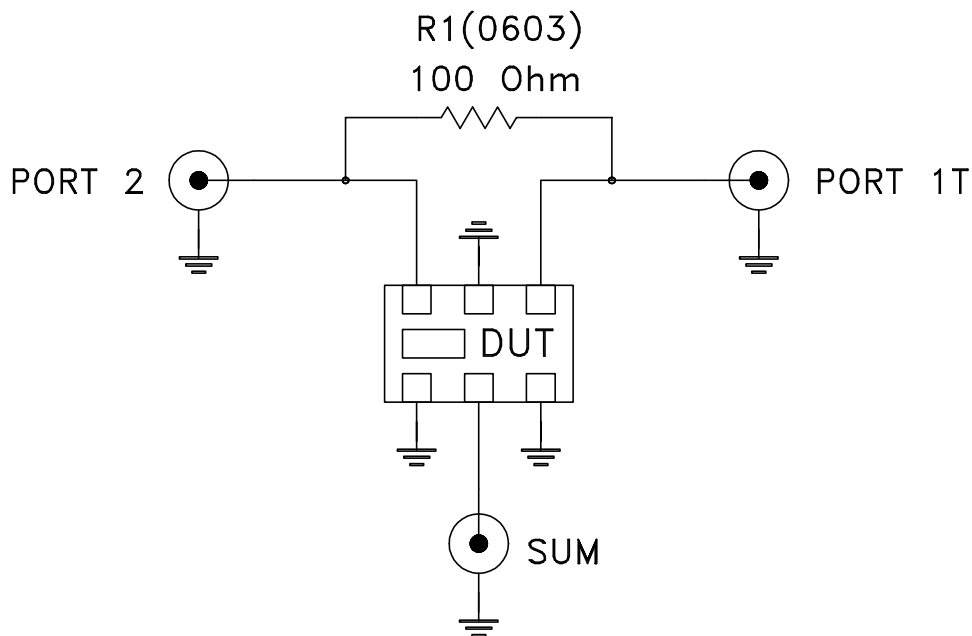
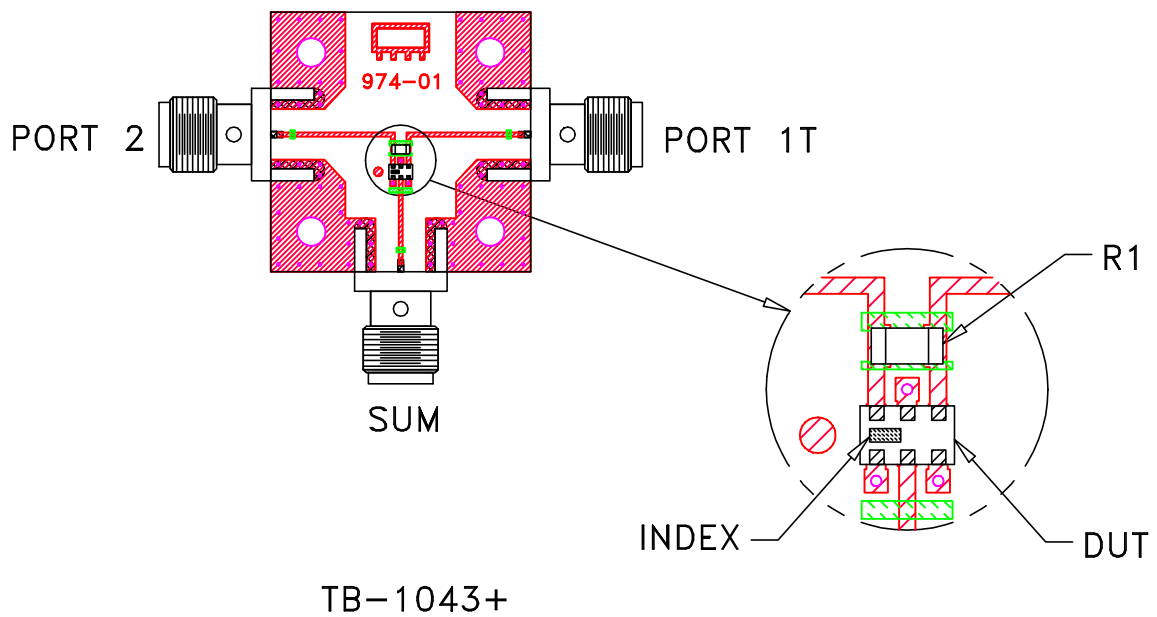

Schematic Diagram

## Notes:

1. 50 Ohm SMA Female connectors.
2. PCB Material: R04350 or equivalent,  
Dielectric Constant=3.5, Thickness=.0066 inch.

 **Mini-Circuits®**



All Mini-Circuits products are manufactured under exacting quality assurance and control standards, and are capable of meeting published specifications after being subjected to any or all of the following physical and environmental test.

Specification	Test/Inspection Condition	Reference/Spec
Operating Temperature	-55° to 100°C Ambient Environment	Individual Model Data Sheet
Storage Temperature	-55° to 100° C Ambient Environment	Individual Model Data Sheet
Humidity	90 to 95% RH, 240 hours, 50°C	MIL-STD-202, Method 103, Condition A, Except 50°C and end-point electrical test done within 12 hours
Solder Reflow Heat	Sn-Pb Eutetic Process: 225°C peak Pb-Free Process 245° - 250°C peak	J-STD-020, Table 4-1, 4-2 and 5-2, Figure 5-1
Solderability	10X Magnification	J-STD-002, Para 4.2.5, Test S, 95% Coverage
Vibration (High Frequency)	20g peak, 10-2000 Hz, 12 times in each of three perpendicular directions (total 36)	MIL-STD-202, Method 204, Condition D
Mechanical Shock	50g, 11 ms, 1/2-sine, 18 shocks: 3 each direction, each of 3 axes	MIL-STD-202, Method 213, Condition A