



CERAMIC

Power Splitter/Combiner SCG-2-242AT+

Mini-Circuits

2 Way-0° 50Ω 1000 to 2400 MHz

FEATURES

- Isolation resistor, external 100 ohms
- Low insertion loss, 0.8 dB typ.
- Excellent amplitude unbalance, 0.1 dB typ.
- Excellent phase unbalance, 1.5 deg. typ.
- High isolation, 15 dB typ.
- ESD non-sensitive
- Temperature stable LTCC technology
- Wrap around terminations for excellent solderability
- Low cost
- AEC-Q200 qualified component family



Generic photo used for illustration purposes only
CASE STYLE: GE0805C-1

+RoHS Compliant

The +Suffix identifies RoHS Compliance.
See our website for methodologies and qualifications

APPLICATIONS

- Automotive

ELECTRICAL SPECIFICATIONS¹ AT +25°C

Parameter	Frequency (MHz)	Min.	Typ.	Max.	Unit
Frequency Range		1000		2400	MHz
Insertion Loss, above 3.0 dB	1000 - 2400	—	0.8	1.3	dB
Isolation	1000 - 2400	9	15	—	dB
Phase Unbalance	1000 - 2400	—	1.5	5.0	Degree
Amplitude Unbalance	1000 - 2400	—	0.1	0.3	dB
Return Loss (Input)	1000 - 2400	—	16	—	dB
Return Loss (Output)	1000 - 2400	—	20	—	dB

1. Tested on TB-1043+ using SCG-2-242+ with evaluation board losses de-embedded.

ABSOLUTE MAXIMUM RATINGS

Parameter	Ratings
Operating Temperature	-40°C to +105°C
Storage Temperature	-40°C to +105°C
Power Input (as a splitter) ²	2 W max.
Max. DC Voltage	+5.5 V
Max. DC Current	100 mA at +25 °C
Max. Resistance (SUM PORT-PORT1/PORT2)	1.5 Ω

2. Derate linearly to 0.7 W at +105°C ambient, power input as combiner is limited by the rating of the 100Ω external resistors.

Permanent damage may occur if any of these limits are exceeded.

ELECTRICAL SCHEMATIC

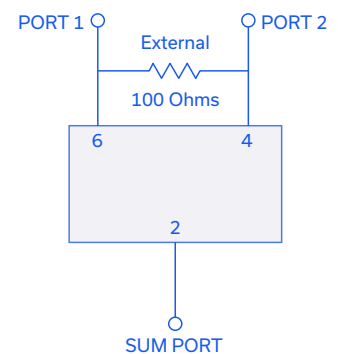



CERAMIC

Power Splitter/Combiner SCG-2-242AT+

Mini-Circuits

2 Way-0° 50Ω 1000 to 2400 MHz

PAD CONNECTIONS

SUM PORT	2
PORT 1	6
PORT 2	4
GROUND	1,3,5
PORT 1-2	100Ω External Resistor

PRODUCT MARKING: PB

DEMO BOARD MCL P/N: TB-1043+
SUGGESTED PCB LAYOUT (PL-560)

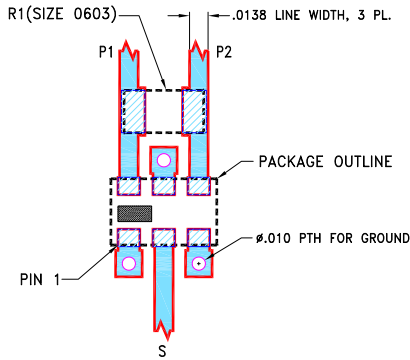

NOTES:

1. LINE WIDTH IS SHOWN FOR ROGERS RO4350B WITH DIELECTRIC THICKNESS .0066±.0007. COPPER: 1/2 OZ. EACH SIDE. FOR OTHER MATERIALS LINE WIDTH MAY NEED TO BE MODIFIED.
2. UNIT FOOT PRINT IS OPTIMIZED FOR PERFORMANCE AND IS DIFFERENT FROM CASE STYLE GE0805C-1 RECOMMENDATIONS.
3. CHIP COMPONENT FOOT PRINT IS SHOWN FOR REFERENCE. FOR COMPONENT VALUE REFER TO TB-1043+.
4. BOTTOM SIDE OF THE PCB IS CONTINUOUS GROUND PLANE.

- DENOTES PCB COPPER LAYOUT WITH SMOBC (SOLDER MASK OVER BARE COPPER).
- DENOTES COPPER LAND PATTERN FREE OF SOLDER MASK.

OUTLINE DRAWING

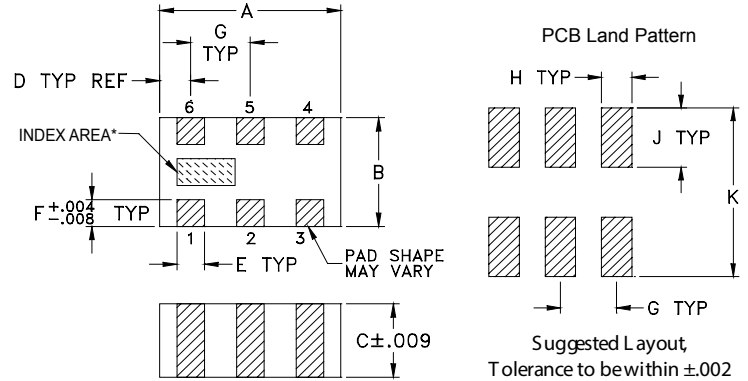

*Shape of index marking may vary

OUTLINE DIMENSIONS (Inches/mm)

A	B	C	D	E	F
.079	.049	.033	.014	.012	.012
2.01	1.24	0.84	0.36	0.30	0.30
G	H	J	K		wt
.026	.014	.039	.110		grams
0.66	0.36	1.00	2.80		.008

TAPE & REEL INFORMATION: F74



CERAMIC

Power Splitter/Combiner SCG-2-242AT+

Mini-Circuits

2 Way-0° 50Ω 1000 to 2400 MHz

TYPICAL PERFORMANCE DATA

Frequency (MHz)	Total Loss ¹ (dB)		Amplitude Unbalance (dB)	Isolation (dB)	Phase Unbalance (deg.)	Return Loss (dB)		
	S-1	S-2				S	1	2
1000	3.55	3.48	0.06	11.54	0.97	12.59	31.25	35.39
1100	3.53	3.46	0.07	12.82	1.08	13.32	37.71	35.95
1200	3.50	3.43	0.06	14.33	1.15	14.24	41.85	32.50
1300	3.47	3.41	0.06	16.11	1.23	15.35	37.93	30.18
1400	3.44	3.38	0.06	18.35	1.22	16.75	34.98	28.76
1500	3.41	3.37	0.05	21.30	1.28	18.49	32.88	27.55
1600	3.40	3.36	0.04	25.56	1.32	20.56	30.93	26.11
1700	3.38	3.36	0.03	32.68	1.39	22.64	28.90	24.73
1800	3.39	3.37	0.02	33.53	1.38	23.24	26.59	23.18
1900	3.42	3.40	0.02	26.53	1.39	21.42	24.25	21.31
2000	3.46	3.44	0.02	22.53	1.37	18.88	22.00	19.55
2100	3.51	3.49	0.02	19.95	1.55	16.56	19.91	17.72
2200	3.59	3.57	0.02	18.07	1.70	14.63	18.04	16.01
2300	3.69	3.67	0.02	16.64	1.77	13.09	16.36	14.63
2400	3.80	3.76	0.04	15.54	1.89	11.85	14.88	13.47

1. Total Loss = Insertion Loss + 3 dB splitter loss.

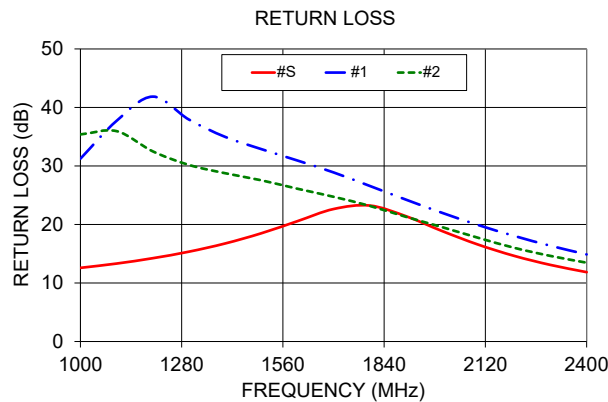
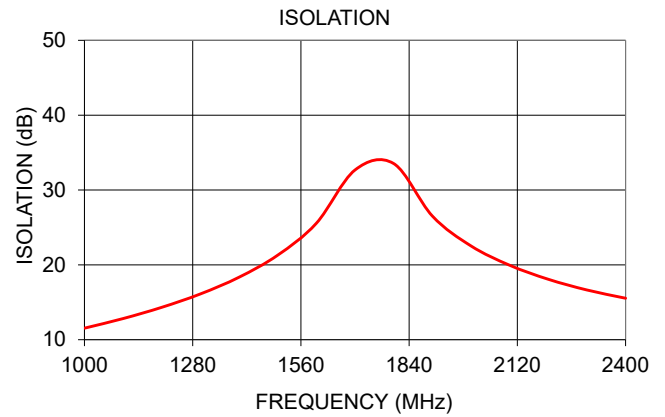
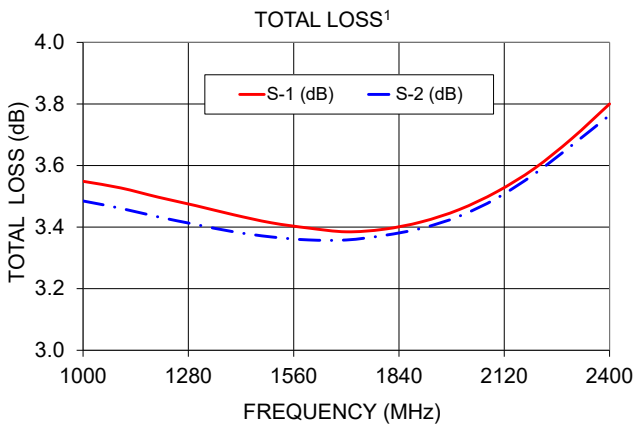

- NOTES**
- A. Performance and quality attributes and conditions not expressly stated in this specification document are intended to be excluded and do not form a part of this specification document.
 - B. Electrical specifications and performance data contained in this specification document are based on Mini-Circuits' applicable established test performance criteria and measurement instructions.
 - C. The parts covered by this specification document are subject to Mini-Circuits standard limited warranty and terms and conditions (collectively, "Standard Terms"); Purchasers of this part are entitled to the rights and benefits contained therein. For a full statement of the standard. Terms and the exclusive rights and remedies thereunder, please visit Mini-Circuits' website at www.minicircuits.com/terms/viewterm.html



Outline Dimensions



PCB Land Pattern



Suggested Layout,
Tolerance to be within ± 0.002

CASE #	A	B	C	D	E	F	G	H	J	K	WT. GRAM
GE0805C-1	.079 (2.00)	.049 (1.25)	.033 (0.84)	.014 (0.35)	.012 (0.30)	.012 (0.30)	.026 (0.65)	.014 (0.35)	.039 (1.00)	.110 (2.80)	.008

Dimensions are in inches (mm). Tolerances: 2Pl. $\pm .01$; 3 Pl. $\pm .005$

Notes:

- Open style, ceramic base.
- Termination finish: For RoHS Case Styles: Tin plate over Nickel plate. All models, (+) suffix.
For RoHS-5 Case Style: Tin-lead plate. All models, no (+) suffix.



P.O. Box 350166, Brooklyn, New York 11235-0003 (718) 934-4500 Fax (718) 332-4661 For detailed performance specs & shopping online see Mini-Circuits web site



The Design Engineers Search Engine Provides ACTUAL Data Instantly From MINI-CIRCUITS At: www.minicircuits.com

RF/IF MICROWAVE COMPONENTS

Tape & Reel Packaging TR-F74

DEVICE ORIENTATION IN T&R

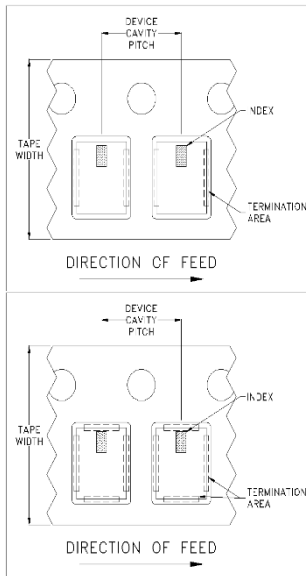

ILLUSTRATION 1

Applicable Case Styles

GE0805C-1
GE0805C-1AP
JV1210C-1
GU2939

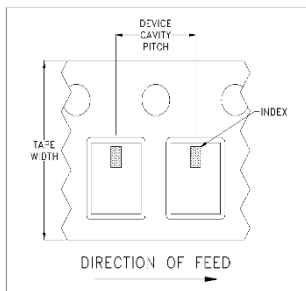

ILLUSTRATION 2

Applicable Case Styles

JV1210C
JV1210C-2
JV1210C-3
JV1210C-4
JV1210C-5
JV1210C-6
JV1210C-11

ILLUSTRATION 3

Applicable Case Styles

JC0603C-8
JC0603C-9
JV1210C-7
JV1210C-8
JV1210C-9
JV1210C-10
JV1210C-13
GE0805C-13
GE0805C-19
GE0805C-20

Tape Width, mm	Device Cavity Pitch, mm	Real Size, inches	Devices per Reel	
8	4	7	Small quantity standards (see note)	20
				50
				100
				200
				500
				1000
			Standard	2000
				4000

Note: Small reel availability varies by model. Refer to pricing and availability on individual model dashboard.

Mini-Circuits carrier tape materials provide protection from ESD (Electro-Static Discharge) during handling and transportation. Tapes are static dissipative and comply with industry standards EIA-481/EIA-541.

Go to: www.minicircuits.com/pages/pdfs/tape.pdf



Distribution Centers NORTH AMERICA 800-654-7949 • 417-335-5935 • Fax 417-335-5945 • EUROPE 44-1252-832600 • Fax 44-1252-837010

Mini-Circuits ISO 9001 & ISO 14001 Certified

INTERNET <http://www.minicircuits.com>

P.O. Box 350166, Brooklyn, New York 11235-0003 (718) 934-4500 Fax (718) 332-4661

THIRD ANGLE PROJECTION

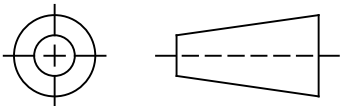

REVISIONS

REV	ECN No.	DESCRIPTION	DATE	DR	AUTH
OR	M172101	NEW RELEASE	02/20/19	ITG	SL
A	ECO-004368	ADDED DIMENSIONS IN [MM]		GF	

SUGGESTED MOUNTING CONFIGURATION
FOR GE0805C-1 CASE STYLE, "06SP17" PIN CODE

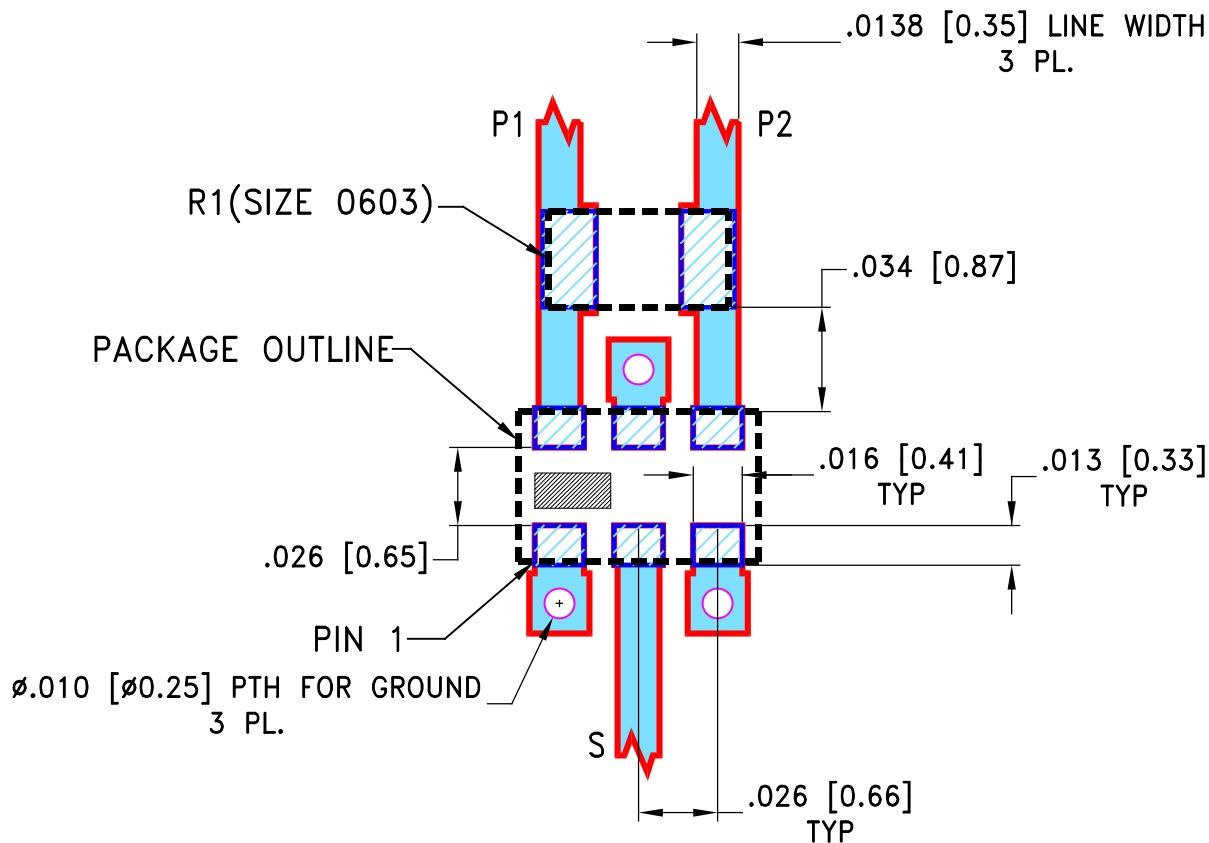

NOTES:

1. LINE WIDTH IS SHOWN FOR ROGERS R04350B WITH DIELECTRIC THICKNESS $.0066 \pm .0007$ [.168 ± .018]. COPPER: 1/2 OZ. EACH SIDE. FOR OTHER MATERIALS LINE WIDTH MAY NEED TO BE MODIFIED.
2. UNIT FOOT PRINT IS OPTIMIZED FOR PERFORMANCE AND IS DIFFERENT FROM CASE STYLE GE0805C-1 RECOMMENDATIONS.
3. CHIP COMPONENT FOOT PRINT IS SHOWN FOR REFERENCE. FOR COMPONENT VALUE REFER TO TB-1043+.
4. BOTTOM SIDE OF THE PCB IS CONTINUOUS GROUND PLANE.



DENOTES PCB COPPER LAYOUT WITH SMOBC (SOLDER MASK OVER BARE COPPER).

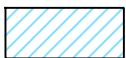

DENOTES COPPER LAND PATTERN FREE OF SOLDER MASK.

UNLESS OTHERWISE SPECIFIED	INITIALS	DATE
DIMENSIONS ARE IN INCHES[MM]	DRAWN ITG	01/21/19
TOLERANCES ON:	CHECKED GF	01/22/19
2 PL DECIMALS ±	APPROVED SL	02/20/19
3 PL DECIMALS ± .005		
ANGLES ±		
FRACTIONS ±		



Mini-Circuits® 13 Neptune Avenue
 Brooklyn NY 11235

PL, 06SP17, GE0805C-1, TB-1043+

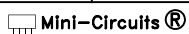

THIS DOCUMENT AND ITS CONTENTS ARE THE PROPERTY OF MINI-CIRCUITS. EXCEPT FOR USE EXPRESSLY GRANTED, IN WRITING, TO ITS VENDORS, VENDEE AND THE UNITED STATES GOVERNMENT, MINI-CIRCUITS RESERVES ALL PROPRIETARY DESIGN, USE, MANUFACTURING AND REPRODUCTION RIGHTS THERETO. THESE CONTENTS SHALL NOT BE USED, DUPLICATED OR DISCLOSED TO ANY OUTSIDE PARTY, IN WHOLE OR IN PART, WITHOUT WRITTEN PERMISSION OF MINI-CIRCUITS.

SIZE	CODE IDENT	DRAWING NO:	REV:
A	15542	98-PL-560	A
FILE:	98PL560	SCALE: 15:1	SHEET: 1 OF 1