

DC Pass, High Power

Bi-Directional Coupler SCBD-20-272HP+

50Ω Up to 100W 1750 to 2750 MHz

The Big Deal

- High power handling, 100W
- Low mainline loss, 0.25 dB
- High directivity, 25 dB
- Excellent return loss, up to 35 dB (input/output/

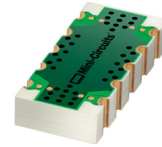

CASE STYLE: JB1233-1

Product Overview

Mini-Circuits' SCBD-20-272HP+ high-power bi-directional coupler provides high power handling up to 100W, low mainline loss, excellent return loss, and good directivity. Covering frequencies from 1750 to 2750 MHz, it supports a wide variety of applications from PCS and ISM to cable TV relay and more. The coupler is designed into an open printed laminate (0.70 x 0.32 x 0.20") with wrap-around terminations for good solderability and easy visual inspection.

Key Features

Feature	Advantages
Wideband, 1750 to 2750 MHz	SCBD-20-272HP+ supports a wide range of system and lab applications.
Low mainline loss, 0.17 – 0.25 dB	Provides excellent through-path signal power transmission.
High directivity, 25 dB	High directivity allows accurate signal sampling through the coupled port with minimal measurement error.
Excellent return loss, 28 - 35 dB (input/output/coupling)	Provides excellent matching for 50Ω systems and minimal signal reflection.
High power handling, 100W	Usable in systems with a wide range of high-power requirements.
DC current passing up to 2A	Suitable for use in systems where DC power is needed through the RF line.

Notes

- A. Performance and quality attributes and conditions not expressly stated in this specification document are intended to be excluded and do not form a part of this specification document.
B. Electrical specifications and performance data contained in this specification document are based on Mini-Circuit's applicable established test performance criteria and measurement instructions.
C. The parts covered by this specification document are subject to Mini-Circuits standard limited warranty and terms and conditions (collectively, "Standard Terms"); Purchasers of this part are entitled to the rights and benefits contained therein. For a full statement of the Standard Terms and the exclusive rights and remedies thereunder, please visit Mini-Circuits' website at www.minicircuits.com/MCLStore/terms.jsp



DC Pass, High Power Bi-Directional Coupler

SCBD-20-272HP+

50Ω Up to 100W 1750 to 2750 MHz

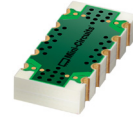

Generic photo used for illustration purposes only

CASE STYLE: JB1233-1

+RoHS Compliant

The +Suffix identifies RoHS Compliance. See our web site for RoHS Compliance methodologies and qualifications

Available Tape and Reel
at no extra cost

Reel Size 13"
Devices/Reel 500

Maximum Ratings

Operating Temperature, case	-55°C to 85°C
Storage Temperature	-55°C to 100°C
DC Current	2A

*Case temperature is defined as temperature on ground leads.
Permanent damage may occur if any of these limits are exceeded.

Pad Connections

INPUT	1,2,3,4
OUTPUT	2,1,4,3
COUPLED IN	4,3,2,1
COUPLED OUT	3,4,1,2
GROUND	5

Product Marking: SCBD-01+

Outline Drawing

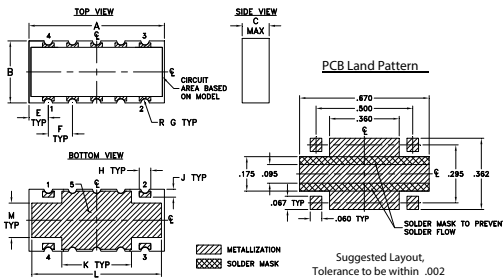

Outline Dimensions (inch/mm)

A	B	C	E	F	G
.70	.32	.14	.100	.125	.022
17.78	8.13	3.56	2.54	3.18	0.56
H	J	K	L	M	wt
.060	.040	.360	.670	.175	grams
1.52	1.02	9.14	17.02	4.45	0.80

Demo Board MCL P/N: TB-774+
Suggested PCB Layout (PL-423)**

** Wraparound solder on ground pins may not be shown

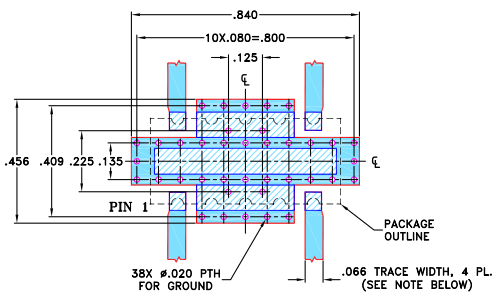

NOTE: 1. TRACE WIDTH IS SHOWN FOR ROGERS R04350B WITH DIELECTRIC THICKNESS .030"±.002"; COPPER: 1/2 OZ. EACH SIDE. FOR OTHER MATERIALS TRACE WIDTH MAY NEED TO BE MODIFIED.
2. BOTTOM SIDE OF THE PCB IS CONTINUOUS GROUND PLANE.

- DENOTES PCB COPPER LAYOUT WITH SMOBC (SOLDER MASK OVER BARE COPPER)
- DENOTES COPPER LAND PATTERN FREE OF SOLDER MASK

Notes

- Performance and quality attributes and conditions not expressly stated in this specification document are intended to be excluded and do not form a part of this specification document.
- Electrical specifications and performance data contained in this specification document are based on Mini-Circuit's applicable established test performance criteria and measurement instructions.
- The parts covered by this specification document are subject to Mini-Circuits standard limited warranty and terms and conditions (collectively, "Standard Terms"); Purchasers of this part are entitled to the rights and benefits contained therein. For a full statement of the Standard Terms and the exclusive rights and remedies thereunder, please visit Mini-Circuits' website at www.minicircuits.com/MCLStore/terms.jsp

Features

- wide frequency range, 1750 to 2700 MHz
- high directivity, 25 dB typ.
- good return loss
- high power, up to 100W
- DC current pass through input to output

Applications

- PCS
- ISM
- cable TV relay
- federal communication

Electrical Specifications at 25°C

Parameter	Condition (MHz)	Min.	Typ.	Max.	Units
Frequency Range		1750		2750	MHz
Mainline Loss ¹	1750-2050	—	0.17	0.25	dB
	2050-2750	—	0.25	0.35	
Coupling	1750-2050	—	20.2±0.6	—	dB
	2050-2750	—	18.6±0.8	—	
Coupling Flatness (±)	1750-2050	—	0.6	0.9	dB
	2050-2750	—	0.8	1.2	
Directivity	1750-2050	22	30	—	dB
	2050-2750	18	24	—	
Return Loss (Input)	1750-2050	20	35	—	dB
	2050-2750	20	28	—	
Return Loss (Output)	1750-2050	20	35	—	dB
	2050-2750	20	29	—	
Return Loss (Coupling)	1750-2050	20	35	—	dB
	2050-2750	20	28	—	
Input Power ² (up to +65°C case temp.)	1750-2750	—	—	100	W
	1750-2750	—	—	64	

1. Include coupling loss.

2. At 65°C with no DC. Derate linearly to 75W (1750-2750 MHz) at 65°C with 2A DC current.

Electrical Schematic

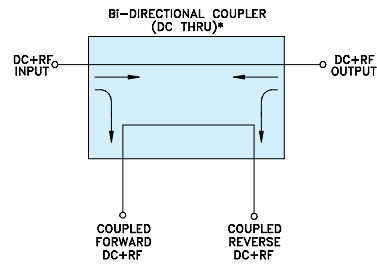

* ELECTRICAL SCHEMATIC IS FOR BI-DIRECTIONAL COUPLER WITHOUT INTERNAL TRANSFORMERS AND RESISTORS.

Mini-Circuits®

www.minicircuits.com P.O. Box 350166, Brooklyn, NY 11235-0003 (718) 934-4500 sales@minicircuits.com

REV. C
ECO-002026
ED-16374
SCBD-20-272HP+
WP/CP/AM
200302
Page 2 of 3

Typical Performance Data

Frequency (MHz)	Mainline Loss (dB)		Coupling (dB)		Directivity (dB)		Return Loss (dB)		
	In-Out	In-Cpl Fwd	Out-Cpl Rev	Out-Cpl Fwd	In-Cpl Rev	In	Out	Cpl Fwd	Cpl Rev
1750	0.11	20.64	20.60	40.44	42.13	50.19	49.60	42.46	47.50
1800	0.11	20.44	20.40	40.37	48.67	43.41	44.78	40.61	53.59
1850	0.11	20.25	20.22	38.93	59.59	38.62	39.50	37.65	45.12
1900	0.12	20.07	20.04	36.34	45.01	36.47	36.38	36.72	39.97
2000	0.12	19.72	19.68	33.04	37.23	32.28	33.08	34.83	35.24
2050	0.13	19.56	19.52	32.68	36.32	31.46	32.10	34.90	33.94
2100	0.14	19.40	19.36	32.66	37.07	31.56	31.91	34.40	32.93
2200	0.15	19.14	19.11	31.67	35.29	31.38	31.40	35.20	31.86
2300	0.17	18.89	18.86	29.24	31.05	33.07	32.32	37.41	32.09
2400	0.18	18.67	18.64	27.18	27.67	34.28	33.65	43.46	33.16
2500	0.19	18.40	18.39	24.12	24.99	39.50	38.35	57.59	36.84
2550	0.19	18.30	18.29	23.35	23.83	48.44	42.96	44.98	39.91
2600	0.21	18.20	18.18	22.36	22.83	78.51	59.89	39.62	45.14
2700	0.21	18.00	17.99	20.69	21.23	36.43	37.12	33.99	42.39
2750	0.23	17.91	17.89	20.07	20.37	33.04	33.50	31.94	37.70

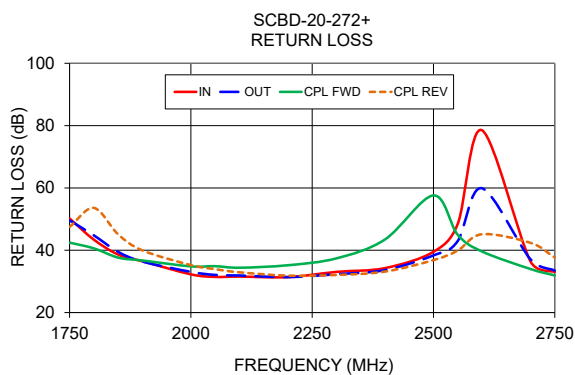
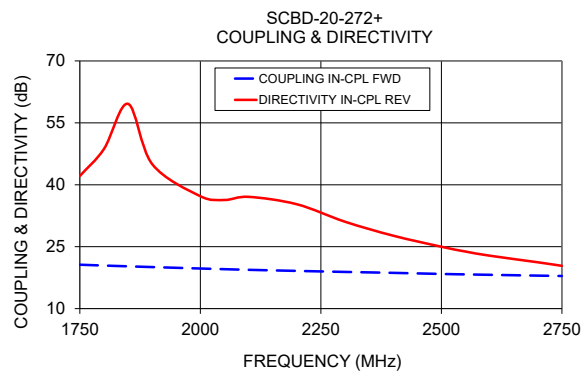
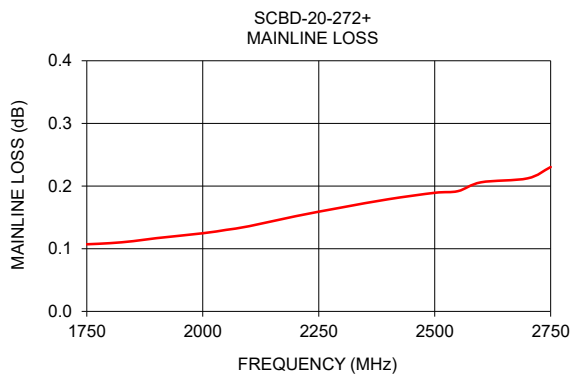

Notes

- Performance and quality attributes and conditions not expressly stated in this specification document are intended to be excluded and do not form a part of this specification document.
- Electrical specifications and performance data contained in this specification document are based on Mini-Circuit's applicable established test performance criteria and measurement instructions.
- The parts covered by this specification document are subject to Mini-Circuits standard limited warranty and terms and conditions (collectively, "Standard Terms"); Purchasers of this part are entitled to the rights and benefits contained therein. For a full statement of the Standard Terms and the exclusive rights and remedies thereunder, please visit Mini-Circuits' website at www.minicircuits.com/MCLStore/terms.jsp



Typical Performance Data

FREQ. (MHz)	INSERTION LOSS		COUPLING		DIRECTIVITY		RETURN LOSS			
	(dB)		(dB)		(dB)		(dB)			
	IN-OUT	FWD-REV	IN-FWD	OUT-REV	IN-REV	OUT-FWD	IN	OUT	FWD	REV
1600	0.10	0.14	21.27	21.24	32.51	32.34	37.53	35.40	42.96	34.87
1620	0.10	0.14	21.18	21.15	33.55	33.59	39.24	36.70	44.74	35.86
1640	0.10	0.14	21.10	21.06	34.60	34.57	40.69	37.93	46.02	36.55
1650	0.10	0.14	21.05	21.02	35.31	35.05	41.60	38.73	47.17	37.07
1660	0.10	0.14	21.01	20.98	36.14	35.68	42.55	39.59	48.29	37.77
1680	0.10	0.14	20.92	20.89	37.12	36.88	43.64	41.46	46.36	39.22
1700	0.10	0.14	20.84	20.80	37.95	37.71	45.36	43.32	44.88	40.94
1720	0.10	0.14	20.76	20.72	39.34	38.74	47.65	45.79	43.93	42.83
1740	0.11	0.14	20.68	20.64	40.76	40.01	49.60	48.72	42.98	45.57
1750	0.11	0.14	20.64	20.60	42.13	40.44	50.19	49.60	42.46	47.50
1760	0.11	0.14	20.60	20.56	43.41	40.52	49.81	49.58	41.96	49.64
1780	0.11	0.14	20.52	20.48	45.87	41.01	46.46	48.28	41.31	51.48
1800	0.11	0.15	20.44	20.40	48.67	40.37	43.41	44.78	40.61	53.59
1820	0.11	0.15	20.36	20.33	54.52	40.06	40.87	41.95	39.06	49.02
1840	0.11	0.15	20.29	20.25	69.93	39.60	39.26	40.34	37.93	45.93
1850	0.11	0.15	20.25	20.22	59.59	38.93	38.62	39.50	37.65	45.12
1860	0.11	0.15	20.22	20.18	52.90	38.02	38.05	38.62	37.41	44.03
1880	0.12	0.15	20.14	20.11	48.49	37.27	37.19	37.39	37.02	41.73
1900	0.12	0.15	20.07	20.04	45.01	36.34	36.47	36.38	36.72	39.97
1920	0.12	0.15	20.00	19.97	42.83	35.78	35.70	35.63	36.27	38.78
1940	0.12	0.15	19.93	19.90	41.25	34.99	34.99	35.03	35.87	37.59
1950	0.12	0.15	19.89	19.86	40.20	34.51	34.52	34.66	35.71	36.98
1960	0.12	0.16	19.86	19.82	38.93	34.03	33.94	34.27	35.48	36.39
1980	0.12	0.16	19.79	19.75	37.76	33.54	33.03	33.70	35.08	35.74
2000	0.12	0.16	19.72	19.68	37.23	33.04	32.28	33.08	34.83	35.24
2020	0.13	0.16	19.66	19.62	36.93	32.78	31.73	32.47	34.60	34.50
2040	0.13	0.16	19.59	19.55	36.50	32.84	31.49	32.18	34.79	34.03
2050	0.13	0.16	19.56	19.52	36.32	32.68	31.46	32.10	34.90	33.94
2060	0.13	0.16	19.52	19.48	36.08	32.48	31.39	32.01	34.83	33.79
2080	0.13	0.17	19.46	19.42	36.75	32.57	31.43	31.95	34.60	33.34
2100	0.14	0.17	19.40	19.36	37.07	32.66	31.56	31.91	34.40	32.93
2120	0.14	0.18	19.35	19.30	37.13	32.60	31.65	31.84	34.48	32.55
2140	0.14	0.18	19.30	19.25	37.22	32.62	31.76	31.72	34.74	32.22
2150	0.14	0.18	19.27	19.23	36.95	32.42	31.72	31.60	34.78	32.05
2160	0.14	0.18	19.25	19.21	36.41	32.22	31.64	31.52	34.83	31.94
2180	0.15	0.18	19.19	19.16	35.97	32.09	31.53	31.44	34.92	31.85
2200	0.15	0.19	19.14	19.11	35.29	31.67	31.38	31.40	35.20	31.86
2220	0.16	0.19	19.10	19.07	34.80	31.16	31.30	31.35	35.39	31.68
2240	0.16	0.19	19.04	19.02	34.07	30.79	31.55	31.52	35.80	31.70
2250	0.16	0.19	19.02	18.99	33.61	30.47	31.75	31.66	36.05	31.74
2260	0.16	0.19	18.99	18.96	32.99	30.07	31.93	31.72	36.23	31.86
2280	0.16	0.20	18.95	18.91	32.19	29.77	32.42	31.98	36.77	31.95
2300	0.17	0.20	18.89	18.86	31.05	29.24	33.07	32.32	37.41	32.09
2320	0.17	0.20	18.85	18.82	30.20	28.81	33.59	32.61	37.95	32.23
2340	0.17	0.20	18.81	18.78	29.43	28.37	34.04	32.86	38.56	32.34
2350	0.17	0.21	18.78	18.75	28.94	28.06	34.13	32.99	38.98	32.41
2360	0.17	0.21	18.76	18.73	28.43	27.81	34.18	33.06	39.50	32.42
2380	0.18	0.21	18.70	18.69	27.85	27.51	34.20	33.25	41.11	32.71
2400	0.18	0.22	18.67	18.64	27.67	27.18	34.28	33.65	43.46	33.16
2450	0.19	0.22	18.52	18.46	25.29	24.57	35.05	34.90	47.62	34.41
2460	0.18	0.22	18.49	18.46	25.42	24.57	35.53	35.59	49.69	35.04
2480	0.19	0.22	18.45	18.43	25.34	24.42	37.29	37.00	57.38	35.99
2500	0.19	0.23	18.40	18.39	24.99	24.12	39.50	38.35	57.59	36.84
2550	0.19	0.23	18.30	18.29	23.83	23.35	48.44	42.96	44.98	39.91
2600	0.21	0.24	18.20	18.18	22.83	22.36	78.51	59.89	39.62	45.14
2650	0.21	0.24	18.09	18.08	22.14	21.39	45.07	45.06	36.29	50.85
2700	0.21	0.25	18.00	17.99	21.23	20.69	36.43	37.12	33.99	42.39
2750	0.23	0.26	17.91	17.89	20.37	20.07	33.04	33.50	31.94	37.70
2780	0.23	0.26	17.84	17.83	19.88	19.78	32.34	32.25	31.28	35.91
2800	0.23	0.26	17.79	17.78	19.58	19.55	31.93	31.34	30.79	34.75
2850	0.22	0.26	17.70	17.71	19.33	19.06	30.11	28.86	29.51	32.19
2900	0.24	0.27	17.63	17.62	19.24	18.83	28.24	27.40	28.39	30.18
2950	0.23	0.26	17.52	17.53	18.93	18.73	26.84	26.52	27.79	28.64
3000	0.22	0.26	17.44	17.43	18.84	18.52	25.84	25.57	27.00	27.38

DC PASS Bi-Directional Coupler

SCBD-20-272HP+

Typical Performance Curves

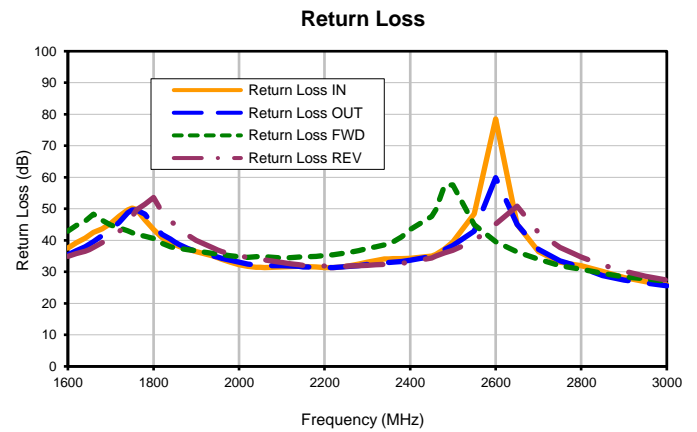
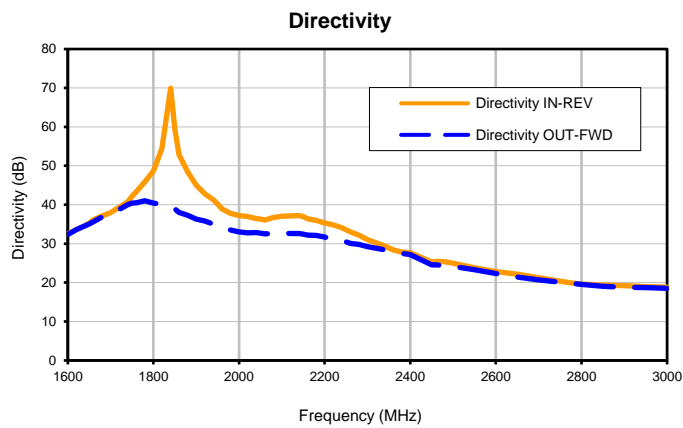
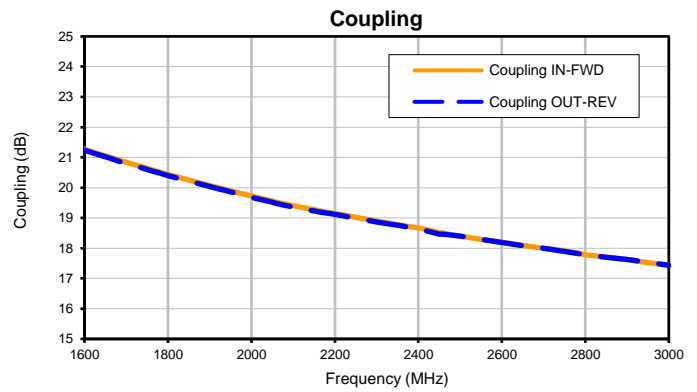
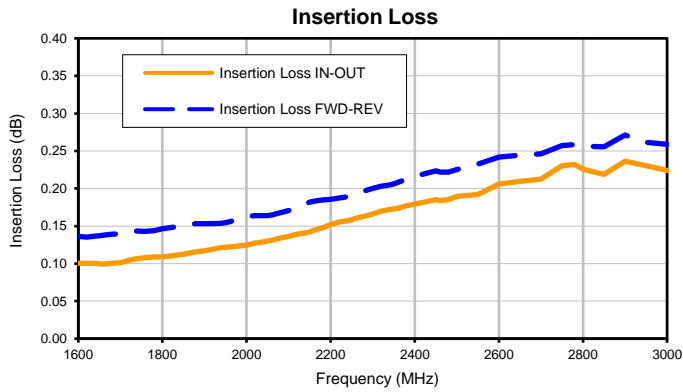

Outline Dimensions

JB1233-1

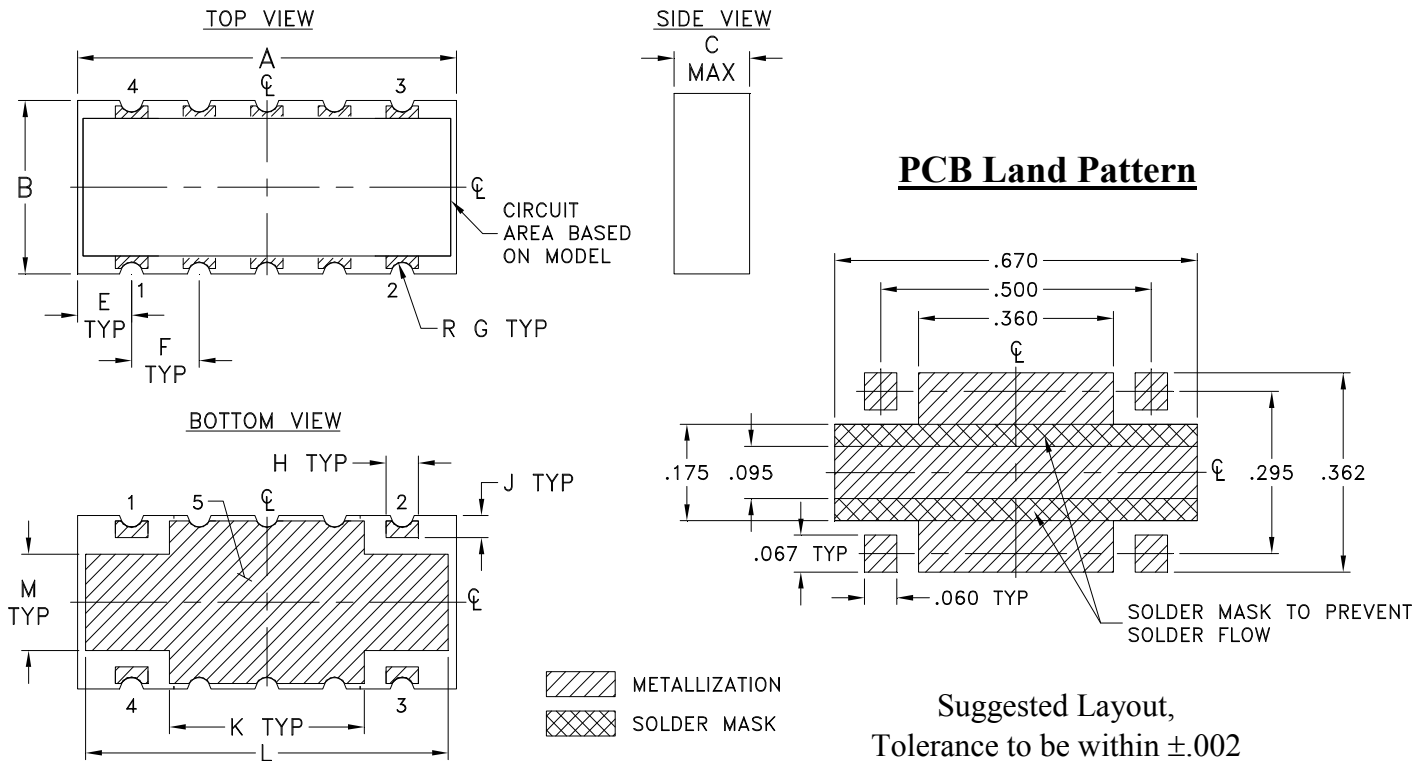

CASE #.	A	B	C	D	E	F	G	H	J	K	L	M	WT, GRAM
JB1233-1	.70 (17.78)	.32 (8.13)	.14 (3.56)	-- --	.100 (2.54)	.125 (3.17)	.022 (0.56)	.060 (1.52)	.040 (1.02)	.360 (9.14)	.670 (17.02)	.175 (4.45)	0.8

Dimensions are in inches (mm). Tolerances: 2 Pl. $\pm .01$; 3 Pl. $\pm .005$

Notes:

- Open style, Base material: Printed wiring laminate.
- Termination finish: 3-5 μ inch (.08-.13 microns) Gold over 120-240 μ inch (3.05-6.10 microns) Nickel plate.
All models, (+) suffix.



INTERNET <http://www.minicircuits.com>

P.O. Box 350166, Brooklyn, New York 11235-0003 (718) 934-4500 Fax (718) 332-4661

Distribution Centers NORTH AMERICA 800-654-7949 • 417-335-5935 • Fax 417-335-5945 • EUROPE 44-1252-832600 • Fax 44-1252-837010

Mini-Circuits ISO 9001 & ISO 14001 Certified

Tape & Reel Packaging TR-F84

DEVICE ORIENTATION IN T&R

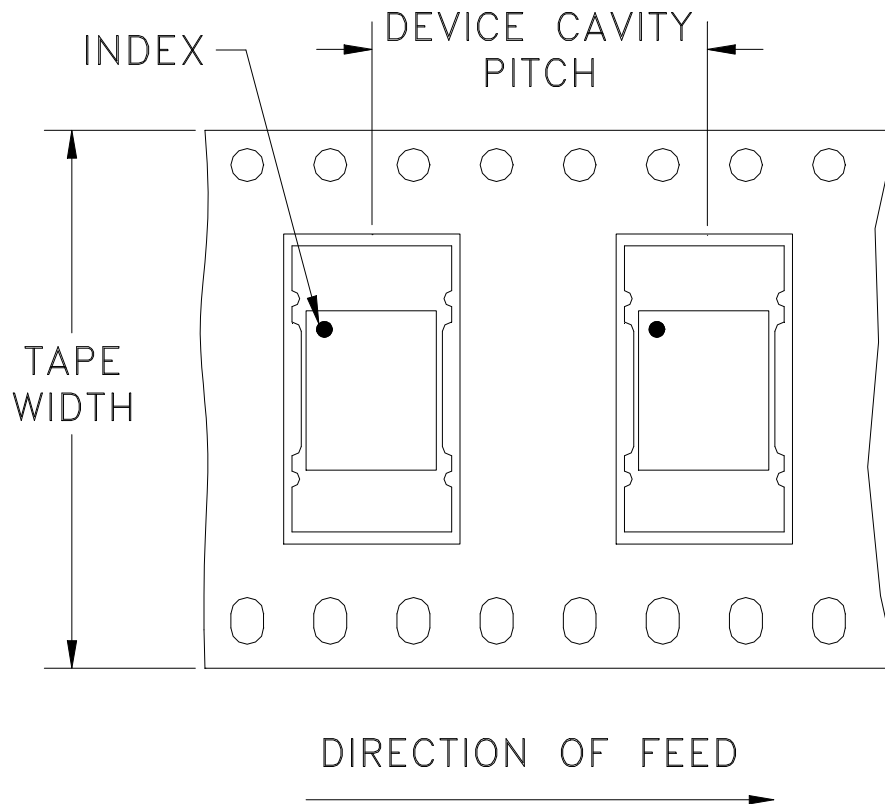

Tape Width, mm	Device Cavity Pitch, mm	Reel Size, inches	Devices per Reel
32	12	13	500

Mini-Circuits carrier tape materials provide protection from ESD (Electro-Static Discharge) during handling and transportation. Tapes are static dissipative and comply with industry standards EIA-481/EIA-541.

Go to: www.minicircuits.com/pages/pdfs/tape.pdf



INTERNET <http://www.minicircuits.com>

P.O. Box 350166, Brooklyn, New York 11235-0003 (718) 934-4500 Fax (718) 332-4661

Distribution Centers NORTH AMERICA 800-654-7949 • 417-335-5935 • Fax 417-335-5945 • EUROPE 44-1252-832600 • Fax 44-1252-837010

Mini-Circuits ISO 9001 & ISO 14001 Certified

THIRD ANGLE PROJECTION

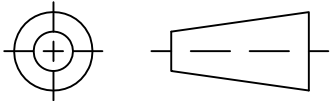

REVISIONS

REV	ECN No.	DESCRIPTION	DATE	DR	AUTH
OR	M147676	NEW RELEASE	07/31/14	ITG	CH

SUGGESTED MOUNTING CONFIGURATION FOR
JB1233-1 CASE STYLE, "05DC02" PIN CODE

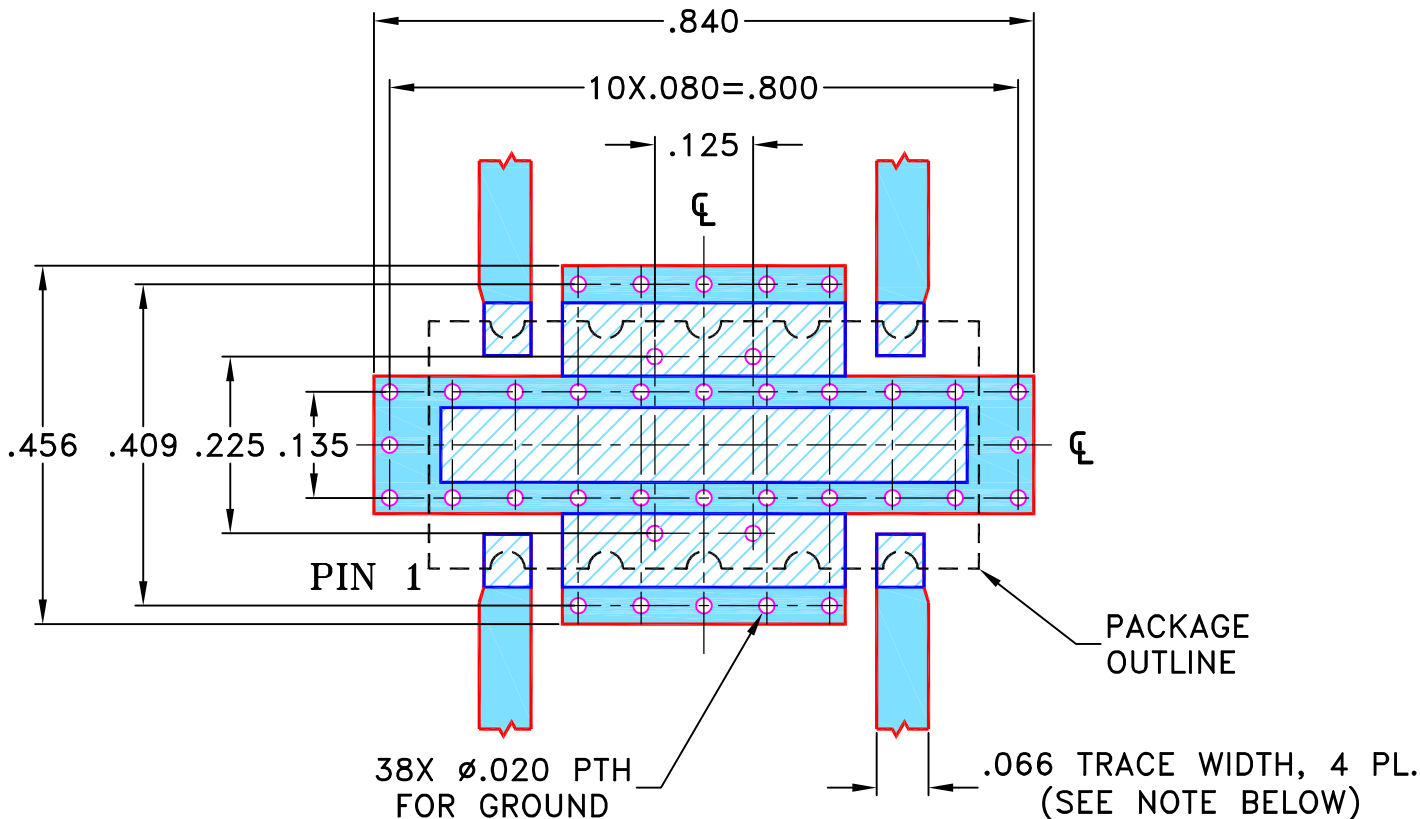

- NOTE: 1. TRACE WIDTH IS SHOWN FOR ROGERS R04350B WITH DIELECTRIC THICKNESS .030"±.002"; COPPER: 1/2 OZ. EACH SIDE.
FOR OTHER MATERIALS TRACE WIDTH MAY NEED TO BE MODIFIED.
2. BOTTOM SIDE OF THE PCB IS CONTINUOUS GROUND PLANE.

- DENOTES PCB COPPER LAYOUT WITH SMOBC (SOLDER MASK OVER BARE COPPER)
- DENOTES COPPER LAND PATTERN FREE OF SOLDER MASK

UNLESS OTHERWISE SPECIFIED	INITIALS		DATE
DIMENSIONS ARE IN INCHES	DRAWN	ITG	07/30/14
TOLERANCES ON:	CHECKED	GF	07/31/14
2 PL DECIMALS ±	APPROVED	CH	07/31/14
3 PL DECIMALS ± .005			
ANGLES ±			
FRACTIONS ±			

Mini-Circuits® 13 Neptune Avenue
Brooklyn NY 11235

PL, 05DC02, JB1233-1, TB-774+

THIS DOCUMENT AND ITS CONTENTS ARE THE PROPERTY OF MINI-CIRCUITS. EXCEPT FOR USE EXPRESSLY GRANTED, IN WRITING, TO ITS VENDORS, VENDEE AND THE UNITED STATES GOVERNMENT, MINI-CIRCUITS RESERVES ALL PROPRIETARY DESIGN, USE, MANUFACTURING AND REPRODUCTION RIGHTS THERETO. THESE CONTENTS SHALL NOT BE USED, DUPLICATED OR DISCLOSED TO ANY OUTSIDE PARTY, IN WHOLE OR IN PART, WITHOUT WRITTEN PERMISSION OF MINI-CIRCUITS.

Mini-Circuits®

SIZE	CODE IDENT	DRAWING NO:	REV:
A	15542	98-PL-423	OR
FILE:	98PL423	SCALE:	4:1
		SHEET:	1 OF 1

Evaluation Board and Circuit

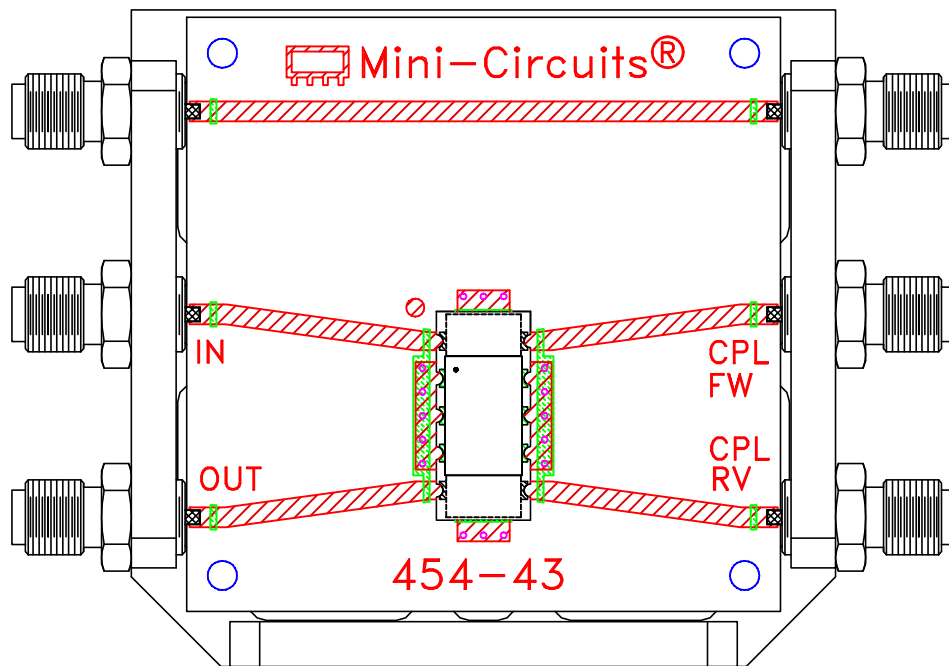

TB-774+

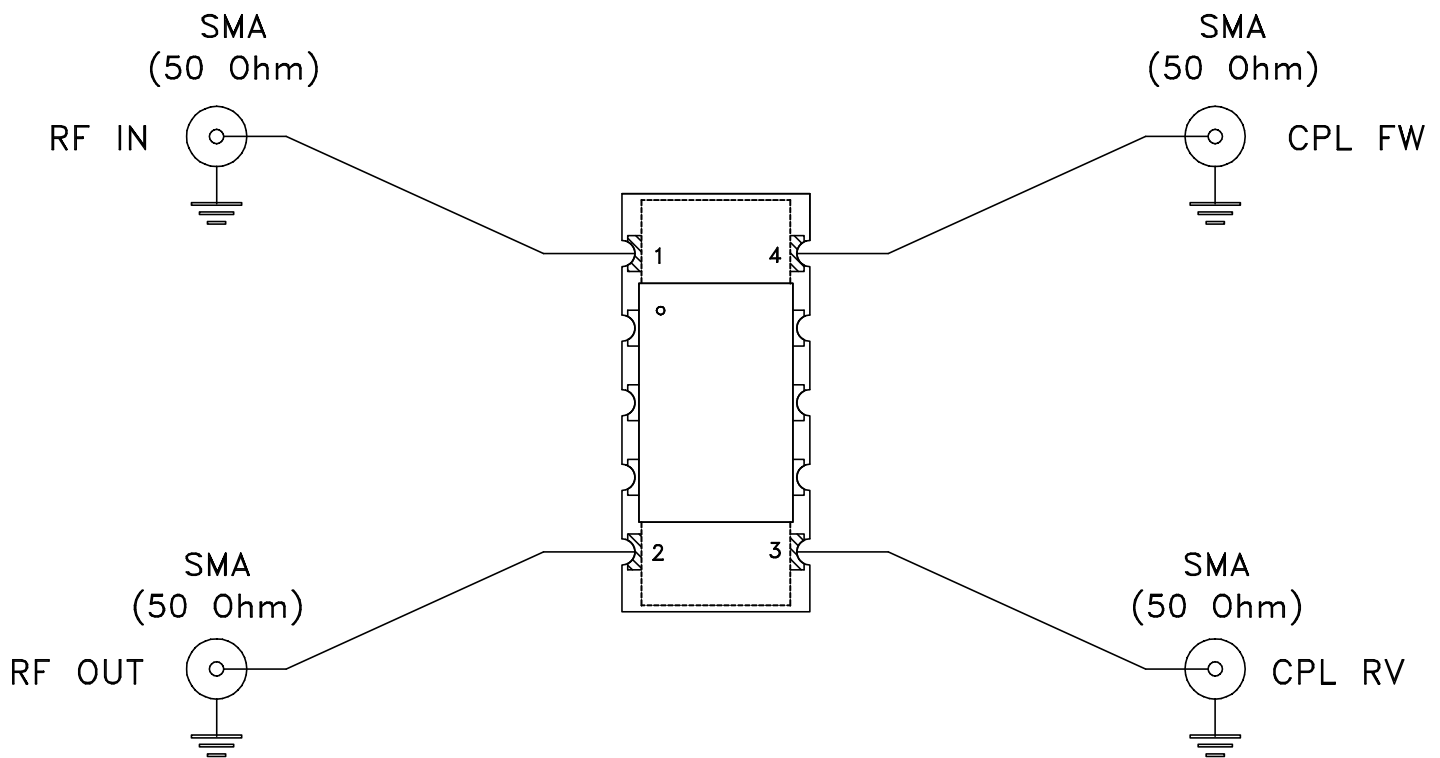

Schematic Diagram

Notes:

1. SMA Female connectors.
2. PCB Material: R04350 or equivalent.
Dielectric Constant=3.5, Thickness=.030 inch.

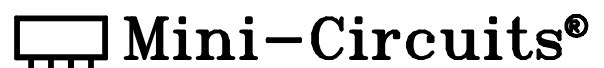

All Mini-Circuits products are manufactured under exacting quality assurance and control standards, and are capable of meeting published specifications after being subjected to any or all of the following physical and environmental test.

Specification	Test/Inspection Condition	Reference/Spec
Operating Temperature	-55° to 65° C Case Environment	Individual Model Data Sheet
Storage Temperature	-55° to 100° C Ambient Environment	Individual Model Data Sheet
Humidity	90 to 95% RH, 240 hours, 50°C	MIL-STD-202, Method 103, Condition A, Except 50°C and end-point electrical test done within 12 hours
Thermal Shock	-55° to 100°C, 100 cycles	MIL-STD-202, Method 107, Condition A-3, except +100°C
Solder Reflow Heat	Sn-Pb Eutetic Process: 225°C peak Pb-Free Process 245° - 250°C peak	J-STD-020, Table 4-1, 4-2 and 5-2, Figure 5-1
Solderability	10X Magnification	J-STD-002, Para 4.2.5, Test S, 95% Coverage
Vibration (High Frequency)	20g peak, 10-2000 Hz, 12 times in each of three perpendicular directions (total 36)	MIL-STD-202, Method 204, Condition D
Mechanical Shock	50g, 11 ms, 1/2-sine, 18 shocks: 3 each direction, each of 3 axes	MIL-STD-202, Method 213, Condition A
Marking Resistance to Solvents	Isopropyl alcohol + mineral spirits at 25°C; terpene defluxer at 25°C; distilled water + proylene glycol monomethyl ether + monoethanolamine at 63°C to 70°C	MIL-STD-202, Method 215