

top hat[®]
Surface Mount
Power Splitter/Combiner

SBTCJ-13-75+

2 Way-180° 75Ω 5 to 1000 MHz

Features

- wide band frequency 5-1000 MHz
- low insertion, 1.1 dB typ.
- excellent amplitude unbalance, 0.3 dB typ.
- very good phase unbalance, 2.7 deg. typ.
- external resistor inductor & capacitor required
- aqueous washable
- leads for excellent solderability
- low cost

Applications

- CATV
- cellular
- UHV/VHV



Generic photo used for illustration purposes only

CASE STYLE: DB1627

+RoHS Compliant

The +Suffix identifies RoHS Compliance. See our web site for RoHS Compliance methodologies and qualifications

Available Tape and Reel at no extra cost

Reel Size	Devices/Reel
7"	20, 50, 100, 200, 500
13"	1000, 2000

Electrical Specifications at 25°C

Parameter	Frequency (MHz)	Min.	Typ.	Max.	Unit
Frequency Range		5		1000	MHz
Insertion Loss Above 3.0 dB	5 - 50	—	1.1	1.7	dB
	50 - 500	—	1.2	1.6	
	500 - 1000	—	1.5	2.1	
Isolation	5 - 50	20	29	—	dB
	50 - 500	20	28	—	
	500 - 1000	20	26	—	
Phase Unbalance	5 - 50	—	0.6	3	Degree
	50 - 500	—	2.7	7	
	500 - 1000	—	2.8	9	
Amplitude Unbalance	5 - 50	—	0.4	0.6	dB
	50 - 500	—	0.3	0.5	
	500 - 1000	—	0.8	1.2	
VSWR (Port-S)	5 - 50	—	1.27	1.5	:1
	50 - 500	—	1.15	1.3	
	500 - 1000	—	1.38	1.6	
VSWR (Port 1-2)	5 - 50	—	1.23	1.5	:1
	50 - 500	—	1.24	1.4	
	500 - 1000	—	1.58	1.8	

Maximum Ratings

Parameter	Ratings
Operating Temperature	-40°C to 85°C
Storage Temperature	-55°C to 100°C
Power Input (as a splitter)	1.0W max.

Permanent damage may occur if any of these limits are exceeded.

Product Marking

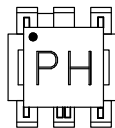

Electrical Schematic

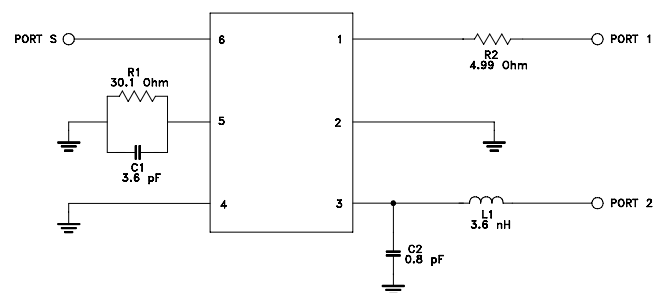

SEQ.	Description	Suggested Supplier Part #
CAP C1	S-SER 3.6±.1 pF; 0603 Size	AVX. 0603 1U3R6 * AT2A
CAP C2	HIQ 0.8 ±.1 pF; 0603 Size	AVX. 0603 1U0R8 * AT2A
IND L1	3.6±.1 nH; 0402 Size	Murat LQP15MN3N6B00
RES R1	.1W 30.1Ω 1%; 0603 Size	KOA RK73HIJTDD30R1F
RES R2	.1W 4.99 Ω 1%; 0603 Size	KOA RK73HIJTDD4R99F

Pin Connections

Function	Pin Number
Sum port	6
port 1 (180°)	1
port 2 (0°)	3
ground	4
Ext. inductor series 3.6nh	3
Ext. capacitor 0.8pf	3 to Gnd
Ext. capacitor 3.6pf	5 to Gnd
Ext. resistor 30.1Ω	5 to Gnd
Ext. resistor series 4.99Ω	1
Ground or not used	2

Outline Drawing

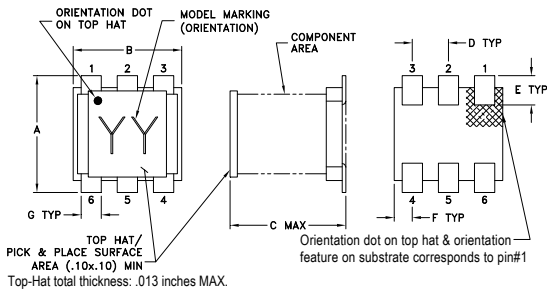

PCB Land Pattern

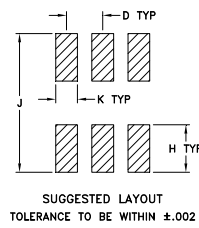

Demo Board MCL P/N: TB-580+ Suggested PCB Layout (PL-342)

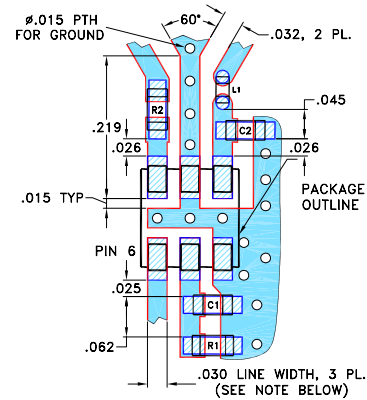

- NOTES: 1. TRACE WIDTH IS SHOWN FOR ROGERS R04350B WITH DIELECTRIC THICKNESS $.030" \pm .002"$; COPPER: 1/2 OZ. EACH SIDE. FOR OTHER MATERIALS TRACE WIDTH MAY NEED TO BE MODIFIED.
2. BOTTOM SIDE OF THE PCB IS CONTINUOUS GROUND PLANE.

DENOTES PCB COPPER LAYOUT WITH SMOBC (SOLDER MASK OVER BARE COPPER)
 DENOTES COPPER LAND PATTERN FREE OF SOLDER MASK

Outline Dimensions (inch / mm)

A	B	C	D	E	F	
.160	.150	.160	.050	.040	.025	
4.06	3.81	4.06	1.27	1.02	0.64	
G	H	J	K		wt	
.028	.065	.190	.030		grams	
0.71	1.65	4.83	0.76		0.15	

Typical Performance Data

Frequency (MHz)	Total Loss ¹ (dB)		Amplitude Unbalance (dB)	Isolation (dB)	Phase Unbalance (deg.)	VSWR S	VSWR 1	VSWR 2
	S-1	S-2						
5.00	4.26	3.92	0.34	30.05	179.61	1.23	1.15	1.19
10.00	4.12	3.82	0.30	29.41	179.60	1.15	1.09	1.13
50.00	4.10	3.85	0.25	28.70	179.99	1.11	1.02	1.09
100.00	4.13	3.89	0.24	28.87	179.77	1.10	1.03	1.08
200.00	4.17	3.94	0.23	28.74	179.39	1.10	1.07	1.06
300.00	4.19	3.99	0.21	28.22	179.06	1.11	1.11	1.04
400.00	4.22	4.04	0.17	27.94	178.93	1.11	1.16	1.06
500.00	4.23	4.12	0.10	27.96	178.85	1.11	1.19	1.09
550.00	4.23	4.18	0.05	28.20	178.94	1.13	1.22	1.10
600.00	4.22	4.21	0.01	28.59	179.11	1.15	1.24	1.11
700.00	4.20	4.32	0.12	29.79	179.42	1.22	1.30	1.14
750.00	4.16	4.36	0.20	30.62	179.59	1.25	1.32	1.16
800.00	4.15	4.40	0.26	31.22	179.85	1.28	1.36	1.17
900.00	4.10	4.54	0.44	30.64	179.53	1.31	1.44	1.21
1000.00	4.10	4.72	0.61	27.70	178.60	1.29	1.55	1.27

1. Total Loss = Insertion Loss + 3dB splitter loss.

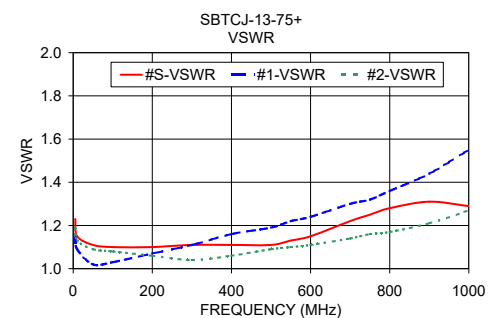
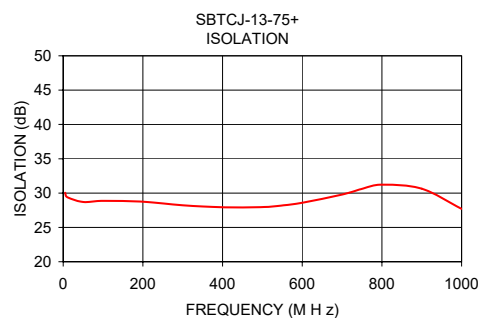
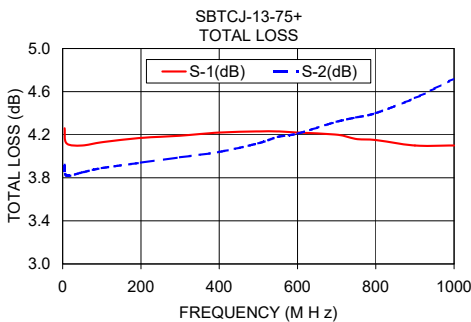

Additional Notes

- A. Performance and quality attributes and conditions not expressly stated in this specification document are intended to be excluded and do not form a part of this specification document.
B. Electrical specifications and performance data contained in this specification document are based on Mini-Circuits' applicable established test performance criteria and measurement instructions.
C. The parts covered by this specification document are subject to Mini-Circuits standard limited warranty and terms and conditions (collectively, "Standard Terms"); Purchasers of this part are entitled to the rights and benefits contained therein. For a full statement of the Standard Terms and the exclusive rights and remedies thereunder, please visit Mini-Circuits' website at www.minicircuits.com/MCLStore/terms.jsp



2 Way-180° Power Splitter/Combiner

SBTCJ-13-75+

Typical Performance Data

FREQUENCY (MHz)	TOTAL LOSS ¹ (dB)		AMPLITUDE UNBALANCE (dB)	ISOLATION (dB) 1-2	PHASE UNBALANCE (deg.)	FREQUENCY (MHz)	VSWR (:1)		
	S-1	S-2					S	1	2
5.0	4.26	3.92	0.34	30.05	179.61	5.0	1.23	1.15	1.19
7.0	4.18	3.86	0.33	30.07	179.58	7.0	1.19	1.12	1.16
9.0	4.14	3.83	0.31	29.62	179.59	9.0	1.16	1.09	1.14
10.0	4.12	3.82	0.30	29.41	179.60	10.0	1.15	1.09	1.13
30.0	4.08	3.82	0.26	28.55	179.85	30.0	1.11	1.03	1.09
50.0	4.10	3.85	0.25	28.70	179.99	50.0	1.11	1.02	1.09
70.0	4.11	3.86	0.24	28.81	179.91	70.0	1.10	1.03	1.09
90.0	4.12	3.88	0.24	28.87	179.82	90.0	1.10	1.03	1.08
100.0	4.13	3.89	0.24	28.87	179.77	100.0	1.10	1.03	1.08
150.0	4.14	3.91	0.23	28.90	179.57	150.0	1.10	1.05	1.07
200.0	4.17	3.94	0.23	28.74	179.39	200.0	1.10	1.07	1.06
250.0	4.18	3.96	0.23	28.49	179.22	250.0	1.10	1.09	1.04
300.0	4.19	3.99	0.21	28.22	179.06	300.0	1.11	1.11	1.04
350.0	4.20	4.01	0.19	28.02	178.99	350.0	1.11	1.14	1.05
400.0	4.22	4.04	0.17	27.94	178.93	400.0	1.11	1.16	1.06
450.0	4.22	4.08	0.15	27.88	178.86	450.0	1.11	1.17	1.07
500.0	4.23	4.12	0.10	27.96	178.85	500.0	1.11	1.19	1.09
550.0	4.23	4.18	0.05	28.20	178.94	550.0	1.13	1.22	1.10
600.0	4.22	4.21	0.01	28.59	179.11	600.0	1.15	1.24	1.11
650.0	4.21	4.26	0.05	29.12	179.25	650.0	1.18	1.27	1.13
700.0	4.20	4.32	0.12	29.79	179.42	700.0	1.22	1.30	1.14
750.0	4.16	4.36	0.20	30.62	179.59	750.0	1.25	1.32	1.16
800.0	4.15	4.40	0.26	31.22	179.85	800.0	1.28	1.36	1.17
850.0	4.13	4.49	0.36	31.18	179.75	850.0	1.30	1.40	1.19
900.0	4.10	4.54	0.44	30.64	179.53	900.0	1.31	1.44	1.21
950.0	4.07	4.61	0.54	29.43	179.12	950.0	1.31	1.50	1.23
1000.0	4.10	4.72	0.61	27.70	178.60	1000.0	1.29	1.55	1.27

¹Total Loss = Insertion Loss + 3dB Splitter Loss



REV. X1

P.O. Box 350166, Brooklyn, New York 11235-0003 (718) 934-4500 • Fax (718) 332-4661 For detailed performance specs & shopping online see Mini-Circuits web site

JSBTCJ-13-75+



The Design Engineers Search Engine Provides ACTUAL Data Instantly From MINI-CIRCUITS At: www.minicircuits.com

12/15/2011

IF/RF MICROWAVE COMPONENTS

Page 1 of 1

2 Way-180° Power Splitter/Combiner

Typical Performance Curves

SBTCJ-13-75+

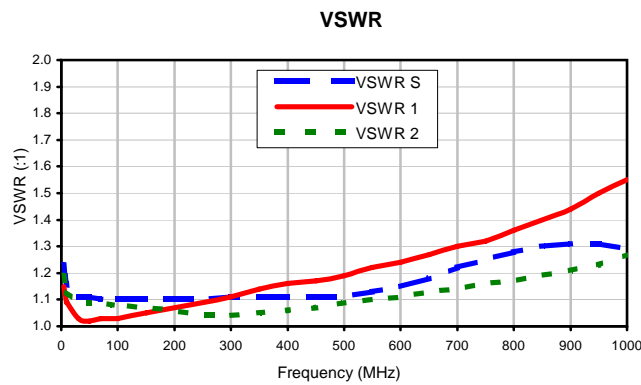
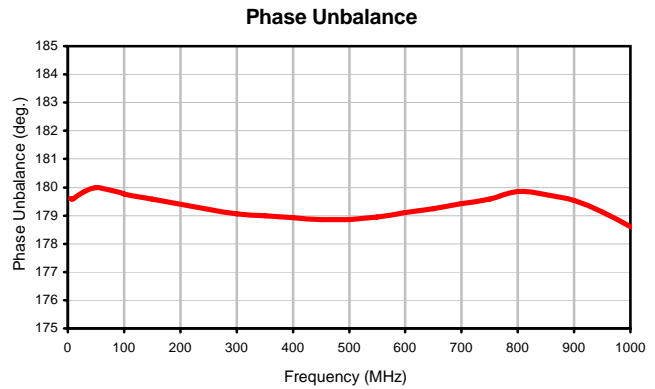
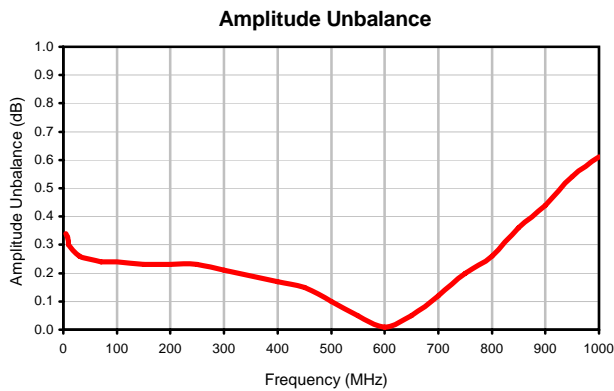
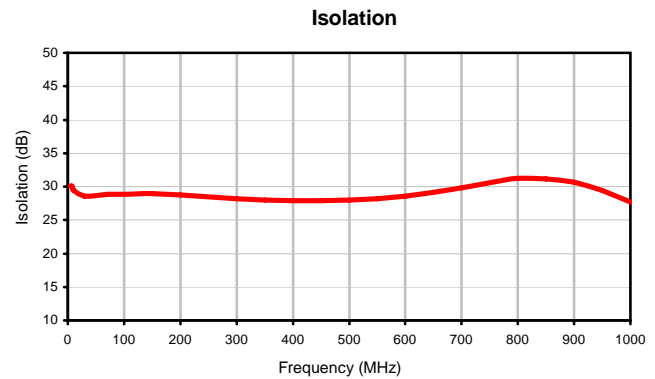
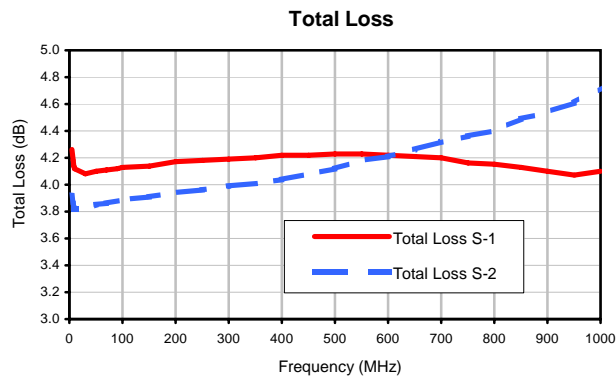

ISO 9001 ISO 14001 AS 9100 CERTIFIED



P.O. Box 350166, Brooklyn, New York 11235-0003 (718) 934-4500 • Fax (718) 332-4661 For detailed performance specs & shopping online see Mini-Circuits web site



The Design Engineers Search Engine Provides ACTUAL Data Instantly From MINI-CIRCUITS At: www.minicircuits.com

IF/RF MICROWAVE COMPONENTS

REV. X1
SBTCJ-13-75+
12/15/2011
Page 1 of 1

Outline Dimensions

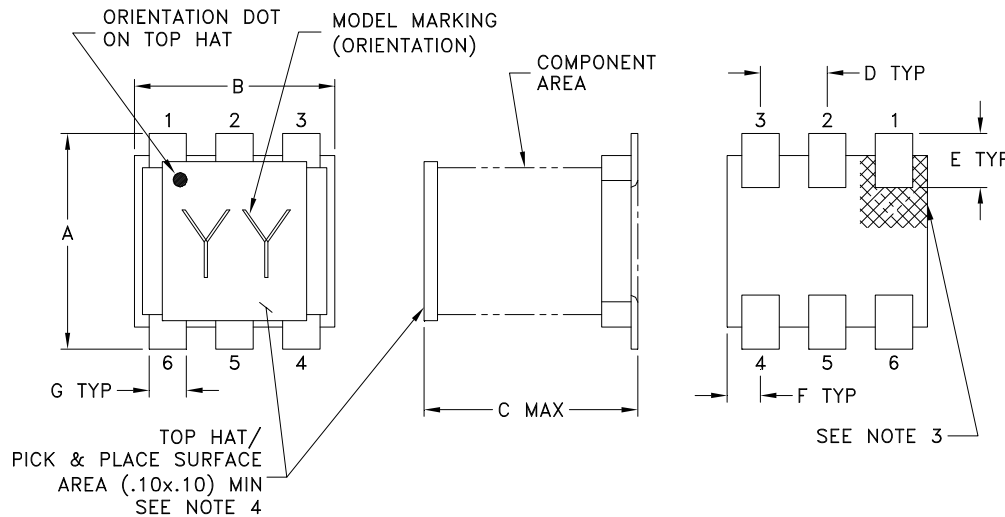

PCB Land Pattern

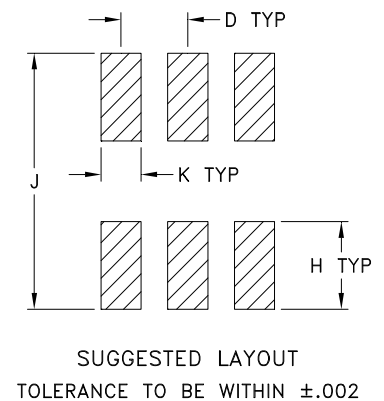

CASE #	A	B	C	D	E	F	G	H	J	K	WT. GRAM
DB1627	.160 (4.06)	.150 (3.81)	.160 (4.06)	.050 (1.27)	.040 (1.02)	.025 (0.64)	.028 (0.71)	.065 (1.65)	.190 (4.83)	.030 (0.76)	.15

Dimensions are in inches (mm). Tolerances: 2 Pl. $\pm .01$; 3Pl. $\pm .005$

Notes:

- Case material: Plastic.
- Termination finish:
For RoHS Case Styles: Tin plate over Nickel plate. All models, (+) suffix.
For RoHS-5 Case Styles: Tin-Lead plate. All models, no (+) suffix.
- Orientation dot on top hat & orientation feature on substrate correspondence to pin #1.
- Top-Hat total thickness: .013 inches MAX.

Tape & Reel Packaging TR-F47

DEVICE ORIENTATION IN T&R

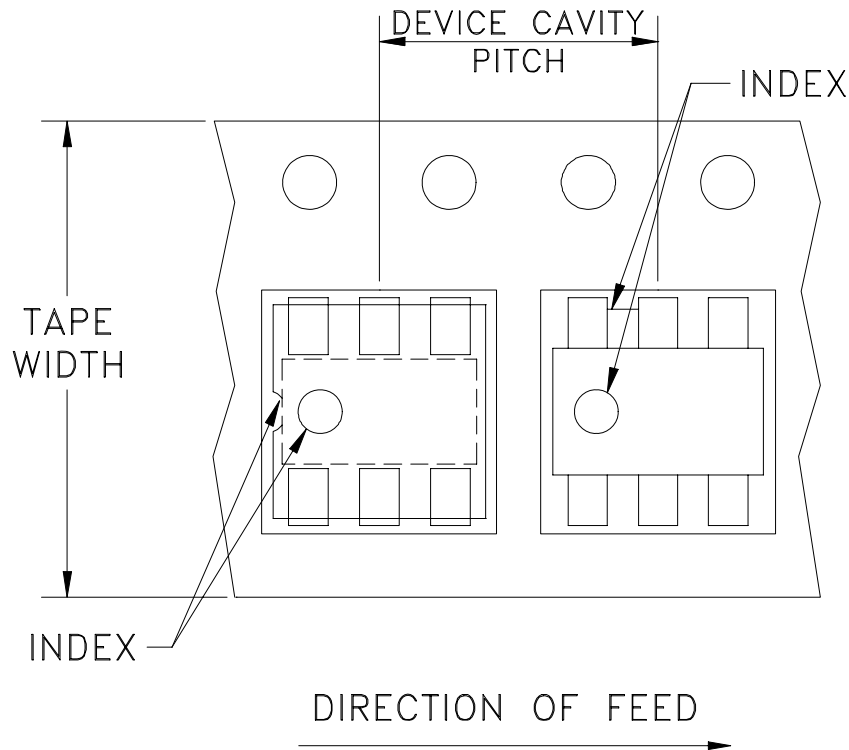

Tape Width, mm	Device Cavity Pitch, mm	Reel Size, inches	Devices per Reel see note
12	8	13	1000, 2000
		7	20, 50, 100, 200, 500

Note: Please consult individual model data sheet to determine device per reel availability.

Mini-Circuits carrier tape materials provide protection from ESD (Electro-Static Discharge) during handling and transportation. Tapes are static dissipative and comply with industry standards EIA-481/EIA-541.

Go to: www.minicircuits.com/pages/pdfs/tape.pdf

 **Mini-Circuits**[®]

INTERNET <http://www.minicircuits.com>

P.O. Box 350166, Brooklyn, New York 11235-0003 (718) 934-4500 Fax (718) 332-4661

Distribution Centers NORTH AMERICA 800-654-7949 • 417-335-5935 • Fax 417-335-5945 • EUROPE 44-1252-832600 • Fax 44-1252-837010

Mini-Circuits ISO 9001 & ISO 14001 Certified

THIRD ANGLE PROJECTION

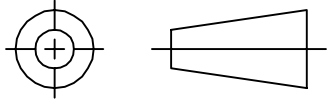

REVISIONS

REV	ECN No.	DESCRIPTION	DATE	DR	AUTH
OR	M130562	NEW RELEASE	03/04/11	GF	JC

SUGGESTED MOUNTING CONFIGURATION FOR DB714 CASE STYLE, "06SP10" PIN CODE

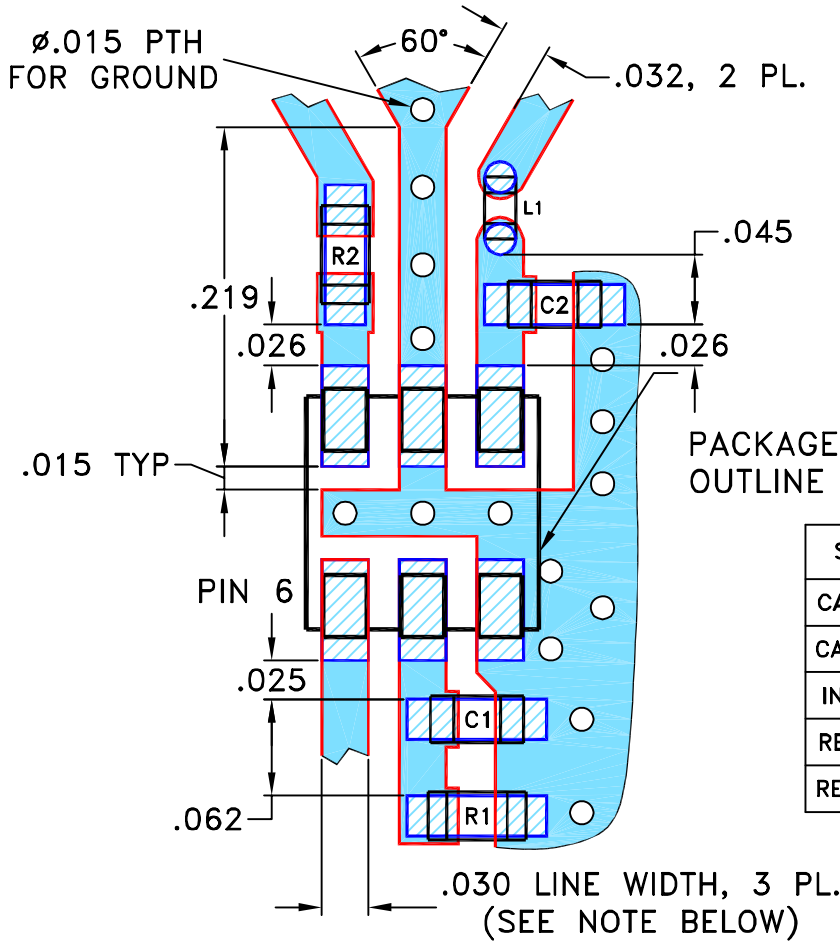

SEQ.	DESCRIPTION
CAP C1	S-SER 3.6 ± .1 pF; 0603 SIZE
CAP C2	HIQ 0.8 ± 1 pF; 0603 SIZE
IND L1	3.6 ± .1 NH; 0402 SIZE
RES R1	.1W 30.1 OHM 1%; 0603 SIZE
RES R2	.1W 4.99 OHM 1%; 0603 SIZE

- NOTES: 1. TRACE WIDTH IS SHOWN FOR ROGERS R04350B WITH DIELECTRIC THICKNESS .030" ± .002"; COPPER: 1/2 OZ. EACH SIDE. FOR OTHER MATERIALS TRACE WIDTH MAY NEED TO BE MODIFIED.
 2. BOTTOM SIDE OF THE PCB IS CONTINUOUS GROUND PLANE.



DENOTES PCB COPPER LAYOUT WITH SMOBC (SOLDER MASK OVER BARE COPPER)



DENOTES COPPER LAND PATTERN FREE OF SOLDER MASK

UNLESS OTHERWISE SPECIFIED	INITIALS		DATE
DIMENSIONS ARE IN INCHES TOLERANCES ON: 2 PL DECIMALS ± 3 PL DECIMALS ± .005 ANGLES ± FRACTIONS ±	DRAWN	GF	02/14/11
	CHECKED	AV	03/04/11
	APPROVED	JC	03/04/11



Mini-Circuits®

13 Neptune Avenue
Brooklyn NY 11235

PL, 06SP10, 75, DB714, TB-580+

THIS DOCUMENT AND ITS CONTENTS ARE THE PROPERTY OF MINI-CIRCUITS. EXCEPT FOR USE EXPRESSLY GRANTED, IN WRITING, TO ITS VENDORS, VENDEE AND THE UNITED STATES GOVERNMENT, MINI-CIRCUITS RESERVES ALL PROPRIETARY DESIGN, USE, MANUFACTURING AND REPRODUCTION RIGHTS THERETO. THESE CONTENTS SHALL NOT BE USED, DUPLICATED OR DISCLOSED TO ANY OUTSIDE PARTY, IN WHOLE OR IN PART, WITHOUT WRITTEN PERMISSION OF MINI-CIRCUITS.

SIZE A	CODE IDENT 15542	DRAWING NO: 98-PL-342	REV: OR
FILE: 98PL342	SCALE: 8:1	SHEET: 1 OF 1	

Evaluation Board and Circuit

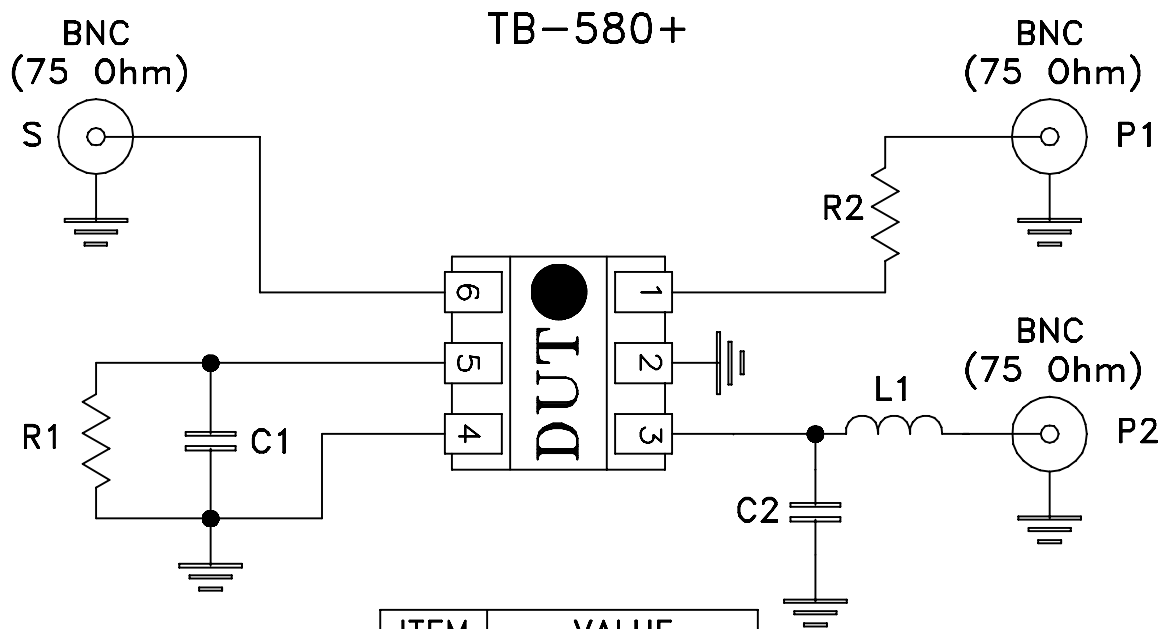
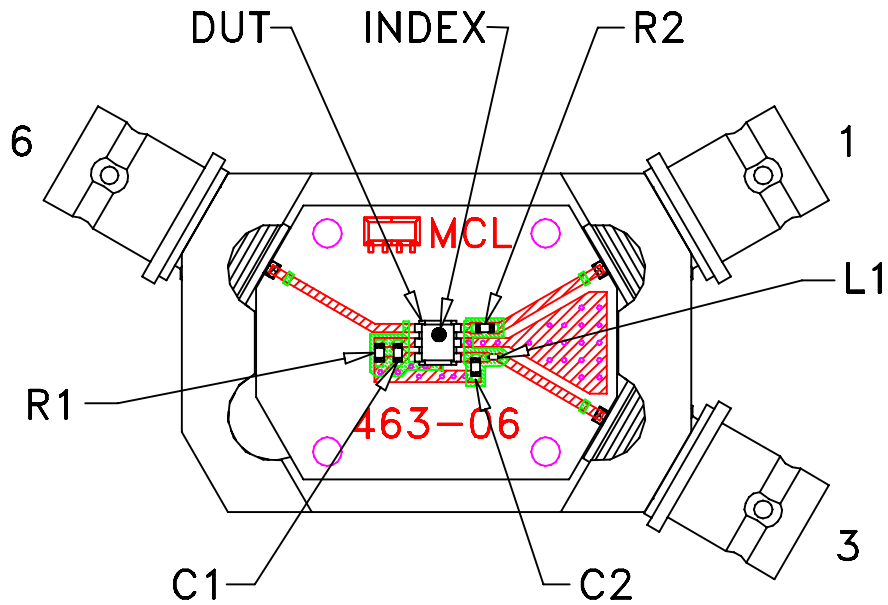

ITEM	VALUE
R1	30.1 OHM
R2	4.99 OHM
C1	3.6 pF
C2	0.8 pF
L1	3.6 nH

Notes:

- 75 Ohm BNC connectors.
- PCB Material: RO4350 or equivalent,
Dielectric Constant=3.5, Thickness=.030 inch.

 Mini-Circuits®



All Mini-Circuits products are manufactured under exacting quality assurance and control standards, and are capable of meeting published specifications after being subjected to any or all of the following physical and environmental test.

Specification	Test/Inspection Condition	Reference/Spec
Operating Temperature	-40° to 85°C Ambient Environment	Individual Model Data Sheet
Storage Temperature	-55° to 100° C Ambient Environment	Individual Model Data Sheet
Humidity	90 to 95% RH, 240 hours, 50°C	MIL-STD-202, Method 103, Condition A, Except 50°C and end-point electrical test done within 12 hours
Thermal Shock	-55° to 100°C, 100 cycles	MIL-STD-202, Method 107, Condition A-3, except +100°C
Solder Reflow Heat	Sn-Pb Eutetic Process: 225°C peak Pb-Free Process 245° - 250°C peak	J-STD-020, Table 4-1, 4-2 and 5-2, Figure 5-1
Solderability	10X Magnification	J-STD-002, 95% Coverage
Vibration (High Frequency)	20g peak, 10-2000 Hz, 12 times in each of three perpendicular directions (total 36)	MIL-STD-202, Method 204, Condition D
Mechanical Shock	50g, 11 ms, 1/2-sine, 18 shocks: 3 each direction, each of 3 axes	MIL-STD-202, Method 213, Condition A
Marking Resistance to Solvents	Isopropyl alcohol + mineral spirits at 25°C; terpene defluxer at 25°C; distilled water + proylene glycol monomethyl ether + monoethanolamine at 63°C to 70°C	MIL-STD-202, Method 215