

Surface Mount  **Power Splitter/Combiner**

SBTC-2-10X+

2 Way-0° 50Ω 5 to 1000 MHz

Features

- low insertion loss, 0.3 dB typ.
- excellent amplitude unbalance, 0. dB typ.
- very good phase unbalance, 1.0 deg. typ.
- temperature stable LTCC base
- small size
- low cost
- aqueous washable
- protected by US patent 6,963,255

Applications

- UHF/VHF receivers/transmitters
- cellular

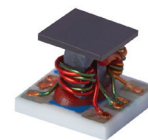

Generic photo used for illustration purposes only

CASE STYLE: AT1667

+RoHS Compliant

The +Suffix identifies RoHS Compliance. See our web site for RoHS Compliance methodologies and qualifications

 Available Tape and Reel at no extra cost	
Reel Size	Devices/Reel
13"	500

Electrical Specifications

Parameter	Frequency (MHz)	Min.	Typ.	Max.	Unit
Frequency Range		5		1000	MHz
Insertion Loss Above 3.0 dB	5 - 50	—	0.3	0.7	dB
	50 - 500	—	0.3	0.8	
	500 - 1000	—	0.5	1.4	
Isolation	5 - 50	20	29	—	dB
	50 - 500	18	25	—	
	500 - 1000	16	21	—	
Phase Unbalance	5 - 50	—	—	3	Degree
	50 - 500	—	—	3	
	500 - 1000	—	—	5	
Amplitude Unbalance	5 - 50	—	—	0.6	dB
	50 - 500	—	—	0.5	
	500 - 1000	—	—	0.5	

Maximum Ratings

Parameter	Ratings
Operating Temperature	-40°C to 85°C
Storage Temperature	-55°C to 100°C
Power Input (as a splitter)	0.5W max.
Internal Dissipation	0.125W max

Permanent damage may occur if any of these limits are exceeded.

Pin Connections

Function	Pin Number
SUM PORT	6
PORT 1	3
PORT 2	4
GROUND	1,2
NOT USED	5

Product Marking

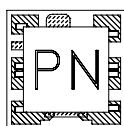

Electrical Schematic



Outline Drawing

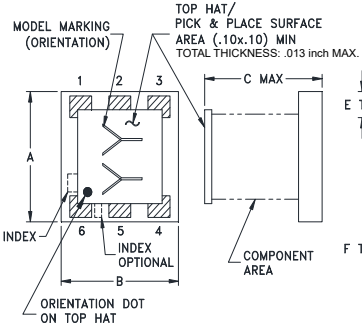

PCB Land Pattern

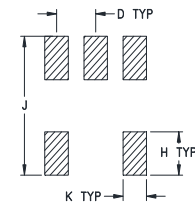

Suggested Layout,
Tolerance to be within ±.002

Outline Dimensions (inch/mm)

A	B	C	D	E	F
.150	.150	.150	.050	.030	.025
3.81	3.81	3.81	1.27	0.76	0.64
G	H	J	K	wt	
.028	.050	.160	.030	grams	
0.71	1.27	4.06	0.76	0.10	

Demo Board MCL P/N: TB-274 Suggested PCB Layout (PL-152)

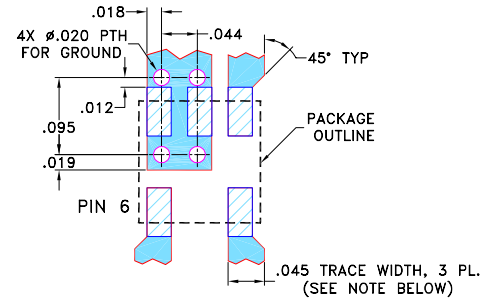

NOTE: 1. TRACE WIDTH IS SHOWN FOR ROGERS RO4350B WITH DIELECTRIC THICKNESS 0.020" ± 0.0015"; COPPER: 1/2 OZ. EACH SIDE. FOR OTHER MATERIALS TRACE WIDTH MAY NEED TO BE MODIFIED.
2. BOTTOM SIDE OF THE PCB IS CONTINUOUS GROUND PLANE.

- DENOTES PCB COPPER LAYOUT WITH SMOBC (SOLDER MASK OVER BARE COPPER)
- DENOTES COPPER LAND PATTERN FREE OF SOLDER MASK

Typical Performance Data

Frequency (MHz)	Total Loss ¹ (dB)		Amplitude Unbalance (dB)	Isolation (dB)	Phase Unbalance (deg.)	VSWR S	VSWR 1	VSWR 2
	S-1	S-2						
5.00	3.25	3.12	0.13	30.21	0.41	1.03	1.17	1.14
7.00	3.24	3.11	0.13	31.41	0.32	1.02	1.16	1.12
10.00	3.26	3.13	0.13	32.34	0.13	1.02	1.15	1.12
50.00	3.26	3.15	0.12	31.93	0.06	1.02	1.14	1.11
70.00	3.28	3.16	0.12	31.37	0.07	1.03	1.14	1.11
100.00	3.29	3.18	0.11	30.43	0.12	1.03	1.13	1.10
200.00	3.34	3.24	0.10	28.05	0.20	1.05	1.12	1.10
300.00	3.38	3.30	0.08	26.00	0.24	1.06	1.11	1.09
400.00	3.39	3.34	0.05	24.32	0.26	1.07	1.09	1.08
500.00	3.45	3.44	0.02	23.24	0.28	1.08	1.07	1.07
600.00	3.48	3.50	0.02	21.78	0.28	1.10	1.05	1.06
700.00	3.45	3.52	0.07	21.08	0.21	1.10	1.02	1.05
800.00	3.47	3.59	0.12	20.74	0.09	1.09	1.03	1.06
900.00	3.49	3.67	0.18	20.62	0.06	1.08	1.06	1.08
1000.00	3.52	3.76	0.24	20.71	0.27	1.06	1.10	1.11

1. Total Loss = Insertion Loss + 3dB splitter loss.

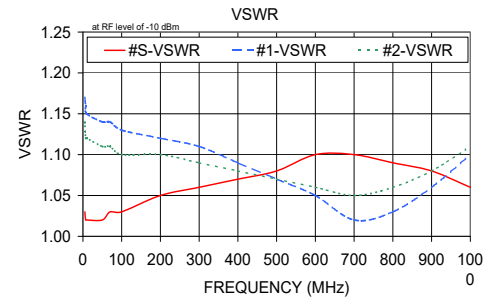
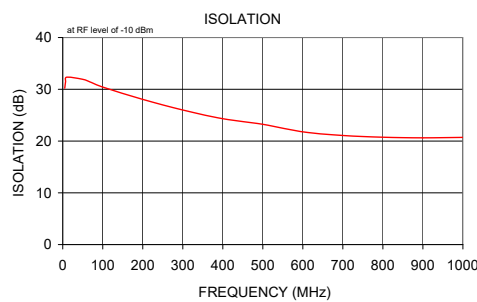
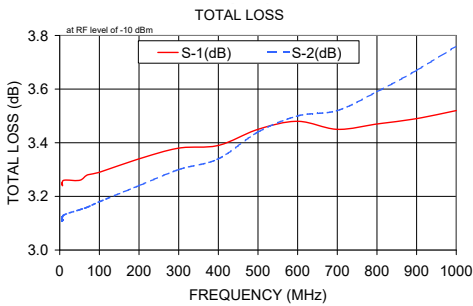

Additional Notes

- Performance and quality attributes and conditions not expressly stated in this specification document are intended to be excluded and do not form a part of this specification document.
- Electrical specifications and performance data contained in this specification document are based on Mini-Circuit's applicable established test performance criteria and measurement instructions.
- The parts covered by this specification document are subject to Mini-Circuits standard limited warranty and terms and conditions (collectively, "Standard Terms"); Purchasers of this part are entitled to the rights and benefits contained therein. For a full statement of the Standard Terms and the exclusive rights and remedies thereunder, please visit Mini-Circuits' website at www.minicircuits.com/MCLStore/terms.jsp

2 Way-0° Power Splitter/Combiner

SBTC-2-10X+

Typical Performance Data

TEST CONDITIONS: INPUT POWER =0 dBm @Temperature = +25°C

FREQUENCY (MHz)	TOTAL LOSS ¹ (dB)		AMPLITUDE UNBALANCE (dB)	ISOLATION (dB)	PHASE UNBALANCE (Deg)	FREQUENCY (MHz)	VSWR (:1)		
	S-1	S-2					S	1	2
5.0	3.25	3.10	0.15	31.14	0.38	5.0	1.03	1.16	1.12
10.0	3.26	3.13	0.13	32.33	0.28	10.0	1.02	1.15	1.10
20.0	3.25	3.12	0.13	32.53	0.09	20.0	1.02	1.14	1.10
30.0	3.25	3.12	0.13	32.15	0.02	30.0	1.02	1.14	1.10
40.0	3.26	3.12	0.13	31.86	0.03	40.0	1.02	1.14	1.10
50.0	3.26	3.13	0.14	31.64	0.05	50.0	1.02	1.14	1.10
100.0	3.29	3.15	0.14	30.58	0.14	100.0	1.03	1.14	1.10
150.0	3.32	3.18	0.14	29.38	0.19	150.0	1.03	1.13	1.10
200.0	3.33	3.20	0.13	28.13	0.28	200.0	1.04	1.12	1.10
250.0	3.35	3.22	0.13	27.01	0.36	250.0	1.04	1.11	1.09
300.0	3.36	3.24	0.12	25.87	0.42	300.0	1.05	1.10	1.09
350.0	3.37	3.26	0.11	24.88	0.49	350.0	1.05	1.09	1.08
400.0	3.39	3.28	0.10	24.03	0.59	400.0	1.06	1.07	1.08
450.0	3.40	3.31	0.09	23.29	0.69	450.0	1.06	1.06	1.07
500.0	3.42	3.33	0.08	22.59	0.76	500.0	1.07	1.05	1.07
550.0	3.43	3.36	0.07	22.03	0.83	550.0	1.07	1.04	1.07
600.0	3.45	3.39	0.06	21.55	0.89	600.0	1.08	1.03	1.07
650.0	3.48	3.42	0.05	21.10	0.95	650.0	1.08	1.03	1.07
700.0	3.50	3.45	0.04	20.73	0.98	700.0	1.09	1.04	1.08
750.0	3.52	3.49	0.03	20.39	1.05	750.0	1.09	1.05	1.09
800.0	3.54	3.53	0.02	20.10	1.09	800.0	1.10	1.07	1.10
850.0	3.58	3.57	0.01	19.86	1.10	850.0	1.10	1.09	1.11
900.0	3.61	3.62	0.01	19.66	1.12	900.0	1.11	1.11	1.12
950.0	3.64	3.67	0.03	19.52	1.12	950.0	1.11	1.13	1.13
1000.0	3.68	3.72	0.04	19.40	1.13	1000.0	1.11	1.14	1.14
1100.0	3.77	3.84	0.07	19.21	1.12	1100.0	1.12	1.18	1.17
1200.0	3.88	3.97	0.10	19.13	1.03	1200.0	1.12	1.22	1.19
1300.0	4.02	4.13	0.12	19.08	0.89	1300.0	1.13	1.26	1.22
1400.0	4.19	4.33	0.13	19.03	0.70	1400.0	1.12	1.29	1.24
1500.0	4.42	4.56	0.14	18.93	0.48	1500.0	1.12	1.32	1.26
1600.0	4.70	4.84	0.14	18.73	0.13	1600.0	1.12	1.35	1.27
1700.0	5.07	5.19	0.12	18.52	0.13	1700.0	1.13	1.39	1.29
1800.0	5.54	5.63	0.08	18.42	0.45	1800.0	1.16	1.43	1.30
1900.0	6.14	6.16	0.02	18.55	0.66	1900.0	1.20	1.47	1.32
2000.0	6.90	6.81	0.09	18.57	0.75	2000.0	1.26	1.52	1.34

¹Total Loss = Insertion Loss + 3dB Splitter Loss

2 Way-0° Power Splitter/Combiner

SBTC-2-10X+

Typical Performance Data

TEST CONDITIONS: INPUT POWER =0 dBm @Temperature = -40°C

FREQUENCY (MHz)	TOTAL LOSS ¹ (dB)		AMPLITUDE UNBALANCE (dB)	ISOLATION (dB)	PHASE UNBALANCE (Deg)	FREQUENCY (MHz)	VSWR (:1)		
	S-1	S-2					S	1	2
	5.0	3.27					3.10	0.17	26.45
10.0	3.22	3.11	0.11	30.18	0.73	10.0	1.03	1.16	1.11
20.0	3.18	3.09	0.09	33.64	0.35	20.0	1.02	1.12	1.08
30.0	3.17	3.08	0.09	34.82	0.18	30.0	1.02	1.11	1.07
40.0	3.17	3.09	0.09	35.53	0.13	40.0	1.02	1.11	1.07
50.0	3.18	3.09	0.09	36.05	0.06	50.0	1.02	1.10	1.07
100.0	3.20	3.11	0.09	33.70	0.04	100.0	1.06	1.11	1.08
150.0	3.22	3.13	0.09	30.47	0.08	150.0	1.05	1.10	1.07
200.0	3.23	3.14	0.09	29.34	0.13	200.0	1.05	1.08	1.07
250.0	3.25	3.16	0.09	27.79	0.18	250.0	1.07	1.09	1.08
300.0	3.25	3.17	0.08	25.82	0.22	300.0	1.08	1.07	1.06
350.0	3.27	3.19	0.08	24.65	0.28	350.0	1.09	1.07	1.06
400.0	3.27	3.20	0.07	23.94	0.34	400.0	1.08	1.05	1.05
450.0	3.28	3.22	0.06	23.22	0.38	450.0	1.09	1.04	1.05
500.0	3.29	3.24	0.05	22.52	0.42	500.0	1.10	1.03	1.05
550.0	3.30	3.26	0.04	21.93	0.44	550.0	1.10	1.02	1.05
600.0	3.31	3.29	0.03	21.43	0.45	600.0	1.10	1.02	1.06
650.0	3.33	3.31	0.02	21.10	0.50	650.0	1.10	1.03	1.07
700.0	3.34	3.33	0.01	20.80	0.51	700.0	1.10	1.04	1.08
750.0	3.36	3.36	0.00	20.33	0.54	750.0	1.11	1.05	1.09
800.0	3.38	3.39	0.01	19.99	0.51	800.0	1.12	1.07	1.09
850.0	3.40	3.43	0.03	19.85	0.49	850.0	1.11	1.09	1.11
900.0	3.43	3.47	0.04	19.62	0.48	900.0	1.12	1.11	1.12
950.0	3.45	3.51	0.06	19.33	0.42	950.0	1.14	1.12	1.13
1000.0	3.48	3.55	0.07	19.18	0.42	1000.0	1.14	1.14	1.14
1100.0	3.55	3.64	0.10	19.06	0.28	1100.0	1.15	1.17	1.16
1200.0	3.63	3.75	0.13	19.07	0.15	1200.0	1.15	1.20	1.19
1300.0	3.74	3.88	0.15	19.05	0.14	1300.0	1.14	1.24	1.22
1400.0	3.88	4.04	0.16	18.94	0.35	1400.0	1.13	1.28	1.24
1500.0	4.07	4.23	0.16	18.82	0.61	1500.0	1.11	1.32	1.26
1600.0	4.33	4.48	0.16	18.35	1.05	1600.0	1.12	1.34	1.27
1700.0	4.67	4.80	0.14	17.83	1.49	1700.0	1.13	1.37	1.28
1800.0	5.12	5.22	0.10	17.46	1.88	1800.0	1.16	1.41	1.30
1900.0	5.75	5.77	0.02	17.57	2.18	1900.0	1.21	1.47	1.32
2000.0	6.57	6.48	0.10	18.29	2.39	2000.0	1.28	1.57	1.37

¹Total Loss = Insertion Loss + 3dB Splitter Loss

2 Way-0° Power Splitter/Combiner

SBTC-2-10X+

Typical Performance Data

TEST CONDITIONS: INPUT POWER =0 dBm @Temperature = +85°C

FREQUENCY (MHz)	TOTAL LOSS ¹ (dB)		AMPLITUDE UNBALANCE (dB)	ISOLATION (dB)	PHASE UNBALANCE (Deg)	FREQUENCY (MHz)	VSWR (:1)		
	S-1	S-2					S	1	2
	5.0	3.34					3.14	0.20	28.74
10.0	3.35	3.17	0.18	29.26	0.25	10.0	1.03	1.20	1.14
20.0	3.34	3.16	0.18	29.11	0.08	20.0	1.03	1.19	1.14
30.0	3.35	3.17	0.18	28.67	0.01	30.0	1.03	1.20	1.14
40.0	3.36	3.17	0.18	28.27	0.03	40.0	1.04	1.20	1.14
50.0	3.37	3.18	0.18	27.95	0.03	50.0	1.03	1.20	1.15
100.0	3.39	3.21	0.18	27.26	0.09	100.0	1.01	1.18	1.13
150.0	3.41	3.24	0.18	27.56	0.16	150.0	1.01	1.17	1.13
200.0	3.43	3.26	0.17	26.83	0.25	200.0	1.03	1.17	1.14
250.0	3.44	3.28	0.16	25.78	0.33	250.0	1.02	1.14	1.12
300.0	3.46	3.30	0.15	25.14	0.44	300.0	1.02	1.12	1.12
350.0	3.47	3.33	0.14	24.54	0.53	350.0	1.02	1.12	1.12
400.0	3.49	3.35	0.13	23.75	0.64	400.0	1.02	1.09	1.10
450.0	3.50	3.38	0.12	23.08	0.75	450.0	1.03	1.08	1.10
500.0	3.53	3.42	0.11	22.50	0.84	500.0	1.03	1.07	1.09
550.0	3.54	3.45	0.09	22.01	0.92	550.0	1.04	1.05	1.09
600.0	3.57	3.49	0.08	21.58	0.98	600.0	1.04	1.04	1.09
650.0	3.60	3.53	0.07	21.18	1.09	650.0	1.05	1.04	1.09
700.0	3.62	3.57	0.05	20.83	1.14	700.0	1.06	1.05	1.09
750.0	3.65	3.61	0.04	20.49	1.23	750.0	1.06	1.06	1.09
800.0	3.68	3.66	0.02	20.23	1.30	800.0	1.07	1.07	1.10
850.0	3.72	3.72	0.01	20.03	1.35	850.0	1.08	1.09	1.11
900.0	3.76	3.77	0.01	19.83	1.37	900.0	1.08	1.11	1.12
950.0	3.80	3.83	0.03	19.66	1.40	950.0	1.09	1.13	1.13
1000.0	3.85	3.89	0.05	19.55	1.47	1000.0	1.10	1.15	1.15
1100.0	3.96	4.04	0.08	19.36	1.51	1100.0	1.11	1.19	1.18
1200.0	4.08	4.20	0.12	19.31	1.49	1200.0	1.12	1.23	1.20
1300.0	4.24	4.38	0.15	19.38	1.39	1300.0	1.13	1.27	1.23
1400.0	4.42	4.59	0.18	19.58	1.28	1400.0	1.13	1.30	1.25
1500.0	4.64	4.83	0.19	19.83	1.09	1500.0	1.12	1.33	1.27
1600.0	4.91	5.12	0.21	20.08	0.87	1600.0	1.12	1.36	1.29
1700.0	5.23	5.44	0.21	20.27	0.58	1700.0	1.11	1.39	1.30
1800.0	5.63	5.83	0.19	20.23	0.36	1800.0	1.13	1.41	1.31
1900.0	6.13	6.28	0.16	19.76	0.16	1900.0	1.16	1.43	1.3
2000.0	6.74	6.84	0.10	18.56	0.06	2000.0	1.22	1.43	1.29

¹Total Loss = Insertion Loss + 3dB Splitter Loss

2 Way-0° Power Splitter/Combiner

SBTC-2-10X+

Typical Performance Curves

Total Loss

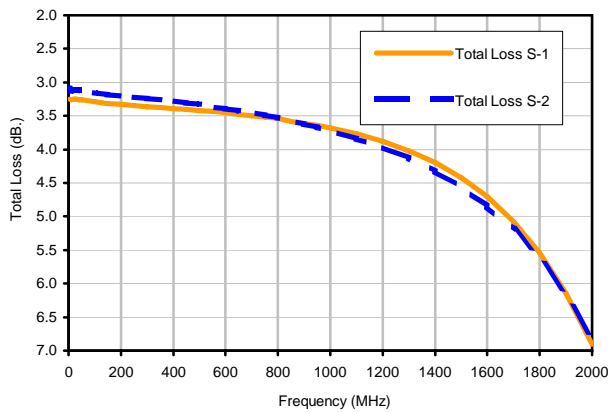

Total Loss S-1 vs. TEMPERATURE

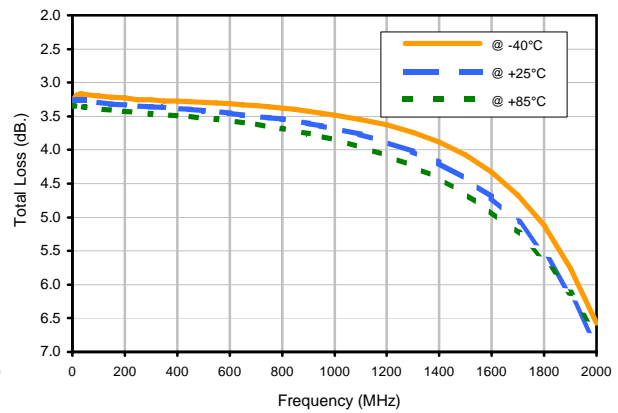

Amplitude Unbalance vs. TEMPERATURE

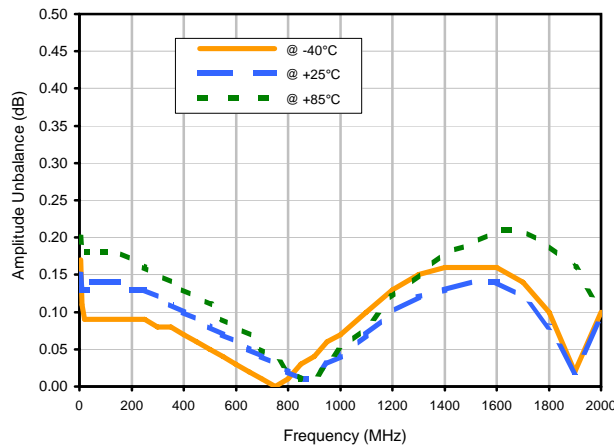

Phase Unbalance vs. TEMPERATURE

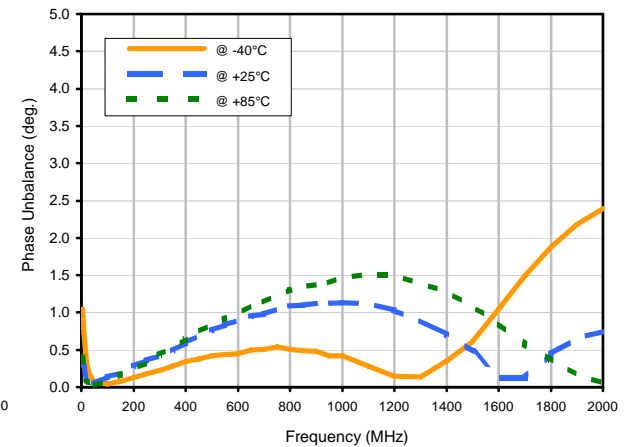

Isolation 1-2 vs. TEMPERATURE

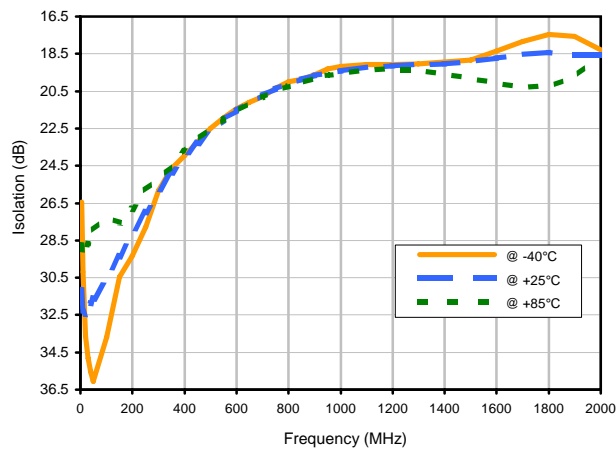

ISO 9001 ISO 14001 AS 9100 CERTIFIED



P.O. Box 350166, Brooklyn, New York 11235-0003 (718) 934-4500 • Fax (718) 332-4661 For detailed performance specs & shopping online see Mini-Circuits web site



The Design Engineers Search Engine Provides ACTUAL Data Instantly From MINI-CIRCUITS At: www.minicircuits.com

IF/RF MICROWAVE COMPONENTS

2 Way-0° Power Splitter/Combiner

SBTC-2-10X+

Typical Performance Curves

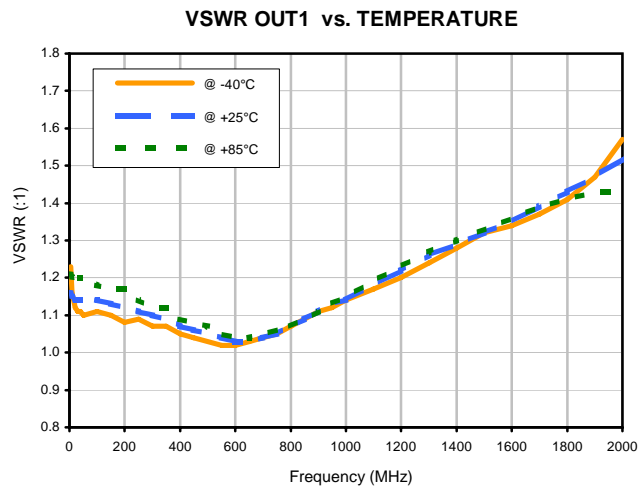
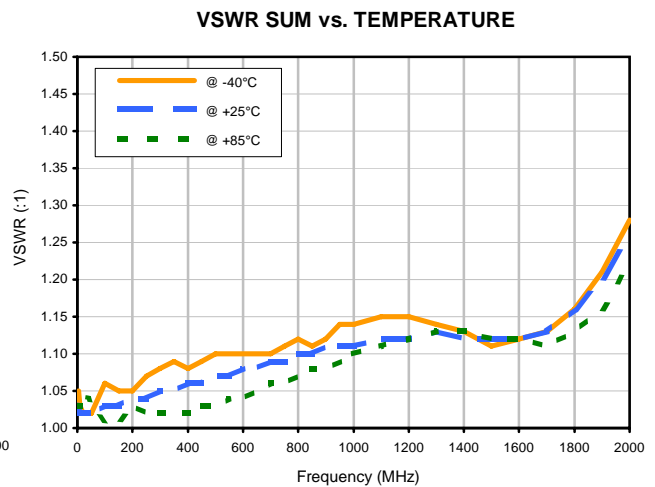
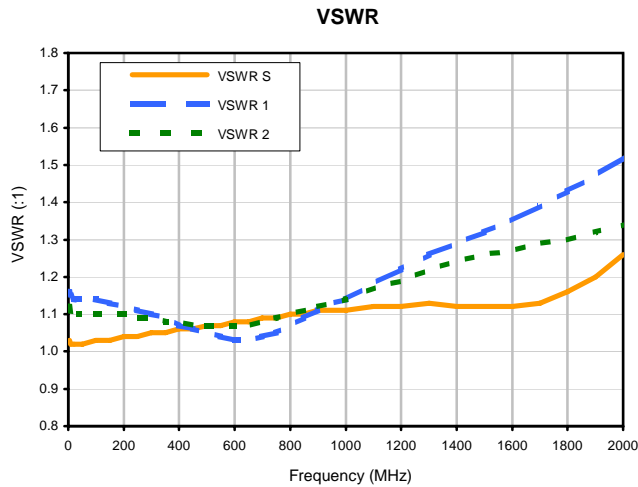

Outline Dimensions

AT1667

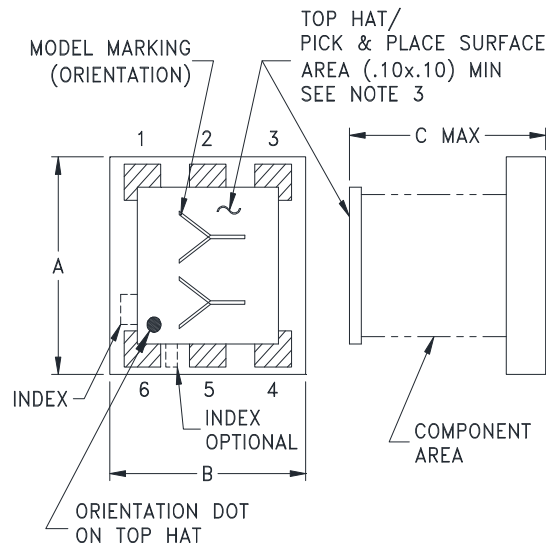

PCB Land Pattern

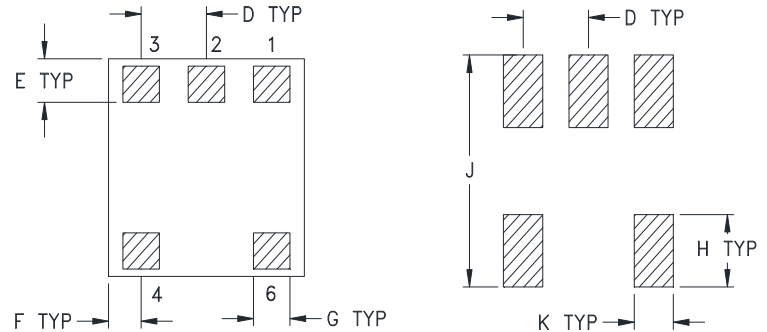

Suggested Layout,
Tolerance to be within $\pm .002$

CASE #	A	B	C	D	E	F	G	H	J	K	L	WT. GRAMS
AT1667	.150 (3.81)	.150 (3.81)	.150 (3.81)	.050 (1.27)	.030 (0.76)	.025 (0.64)	.028 (0.71)	.050 (1.27)	.160 (4.06)	.030 (0.76)	-- --	.10

Dimensions are in inches (mm). Tolerances: 2 Pl. $\pm .01$; 3 Pl. $\pm .005$

Notes:

1. Open style, Ceramic base.
2. Termination finish: Silver Palladium or Gold Over Nickel based on stock availability.
3. Top-hat total thickness: .013 inches MAX.
4. Orientation Dot on Top Hat & Marking on the Substrate both refers to Pin #6 of the Unit.



P.O. Box 350166, Brooklyn, New York 11235-0003 (718) 934-4500 Fax (718) 332-4661 For detailed performance specs & shopping online see Mini-Circuits web site



The Design Engineers Search Engine Provides ACTUAL Data Instantly From MINI-CIRCUITS At: www.minicircuits.com

RF/IF MICROWAVE COMPONENTS

Tape & Reel Packaging TR-F15

DEVICE ORIENTATION IN T&R

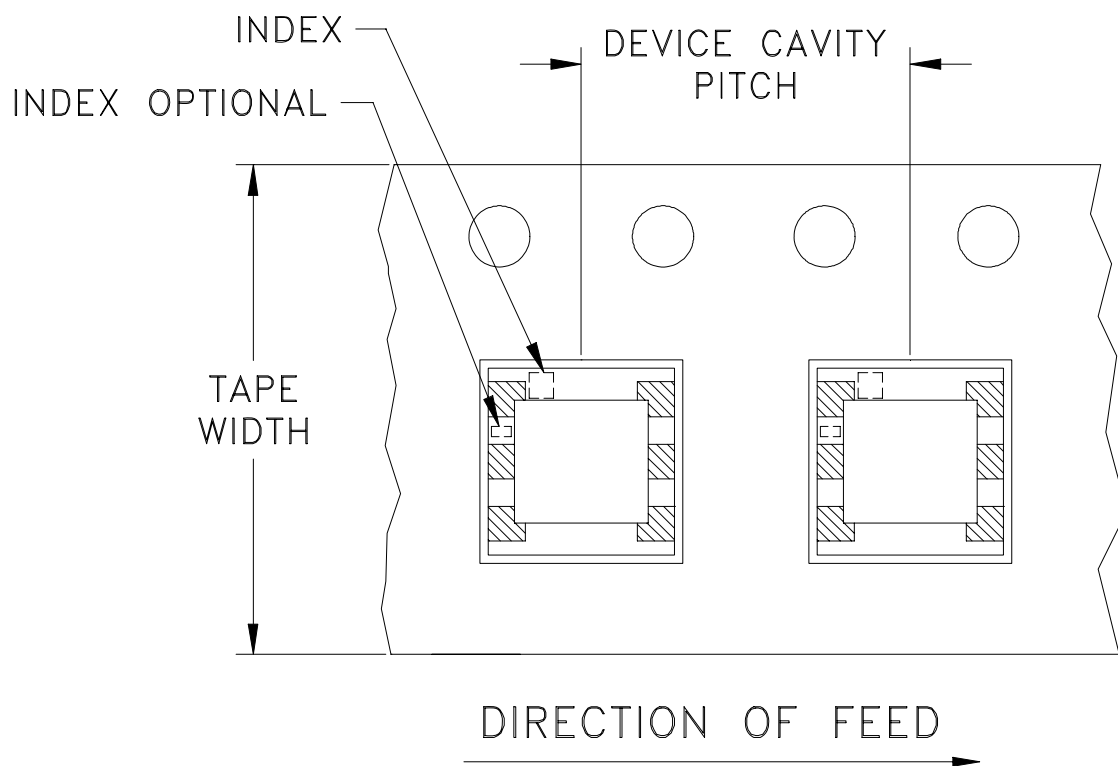

Tape Width, mm	Device Cavity Pitch, mm	Reel Size, inches	Devices per Reel
12	8	7	20
			50
			100
		13	200
			500
			1000
			2000

Note: Please consult individual model data sheet to determine device per reel availability.

Mini-Circuits carrier tape materials provide protection from ESD (Electro-Static Discharge) during handling and transportation. Tapes are static dissipative and comply with industry standards EIA-481/EIA-541.

Go to: www.minicircuits.com/pages/pdfs/tape.pdf



Distribution Centers NORTH AMERICA 800-654-7949 • 417-335-5935 • Fax 417-335-5945 • EUROPE 44-1252-832600 • Fax 44-1252-837010

Mini-Circuits ISO 9001 & ISO 14001 Certified

INTERNET <http://www.minicircuits.com>

P.O. Box 350166, Brooklyn, New York 11235-0003 (718) 934-4500 Fax (718) 332-4661

THIRD ANGLE PROJECTION

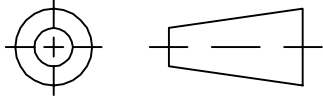

REVISIONS

REV	ECN No.	DESCRIPTION	DATE	DR	AUTH
OR	M90456	NEW RELEASE	01/16/04	AV	WP
A	M102713	ADDED "...WITH SMOBC"	01/12/06	GF	IL

SUGGESTED MOUNTING CONFIGURATION FOR AT1029 CASE STYLE, "nc" PIN CONNECTION

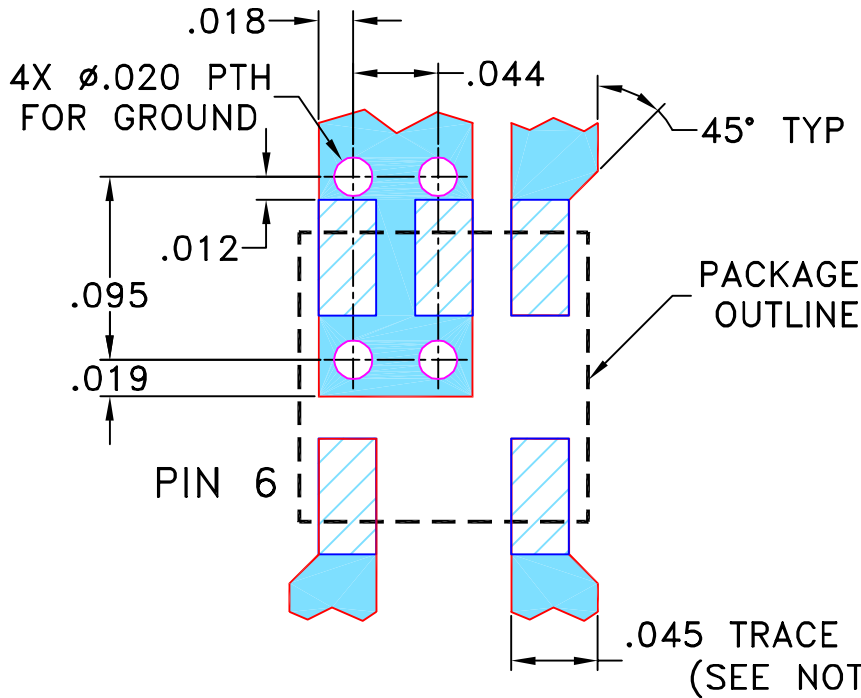

- NOTE: 1. TRACE WIDTH IS SHOWN FOR ROGERS R04350B WITH DIELECTRIC THICKNESS 0.020" ± 0.0015"; COPPER: 1/2 OZ. EACH SIDE. FOR OTHER MATERIALS TRACE WIDTH MAY NEED TO BE MODIFIED.
2. BOTTOM SIDE OF THE PCB IS CONTINUOUS GROUND PLANE.

- DENOTES PCB COPPER LAYOUT WITH SMOBC (SOLDER MASK OVER BARE COPPER)
- DENOTES COPPER LAND PATTERN FREE OF SOLDER MASK

UNLESS OTHERWISE SPECIFIED	INITIALS	DATE
DIMENSIONS ARE IN INCHES	DRAWN AV	01/07/04
TOLERANCES ON:	CHECKED IL	01/16/04
2 PL DECIMALS ±	APPROVED WP	01/16/04
3 PL DECIMALS ± .005		
ANGLES ±		
FRACTIONS ±		

Mini-Circuits® 13 Neptune Avenue
Brooklyn NY 11235

PL, nc, AT1029, SBTC, TB-274

Mini-Circuits®
THIS DOCUMENT AND ITS CONTENTS ARE THE PROPERTY OF MINI-CIRCUITS. EXCEPT FOR USE EXPRESSLY GRANTED, IN WRITING, TO ITS VENDORS, VENDEE AND THE UNITED STATES GOVERNMENT, MINI-CIRCUITS RESERVES ALL PROPRIETARY DESIGN, USE, MANUFACTURING AND REPRODUCTION RIGHTS THERETO. THESE CONTENTS SHALL NOT BE USED, DUPLICATED OR DISCLOSED TO ANY OUTSIDE PARTY, IN WHOLE OR IN PART, WITHOUT WRITTEN PERMISSION OF MINI-CIRCUITS.

SIZE A	CODE IDENT 15542	DRAWING NO: 98-PL-152	REV: A
FILE: 98PL152	SCALE: 10:1	SHEET: 1 OF 1	

Evaluation Board and Circuit

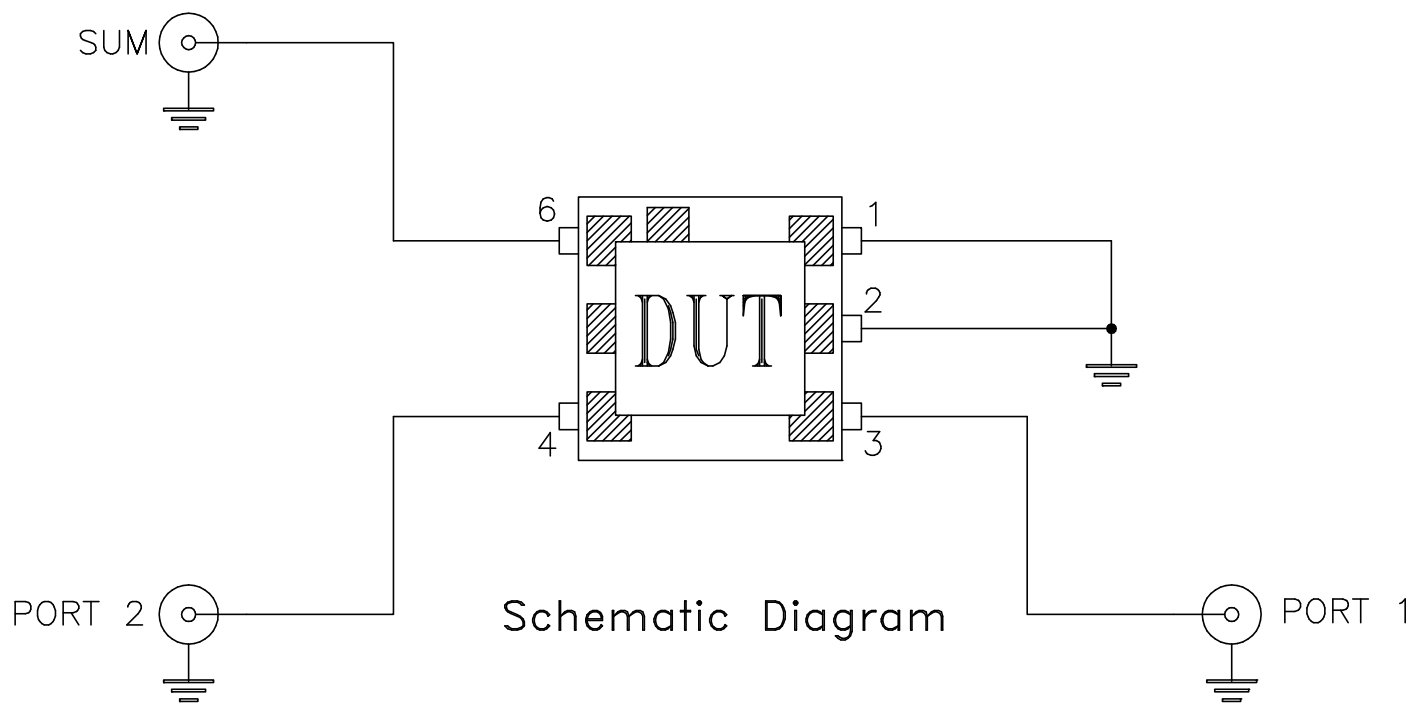
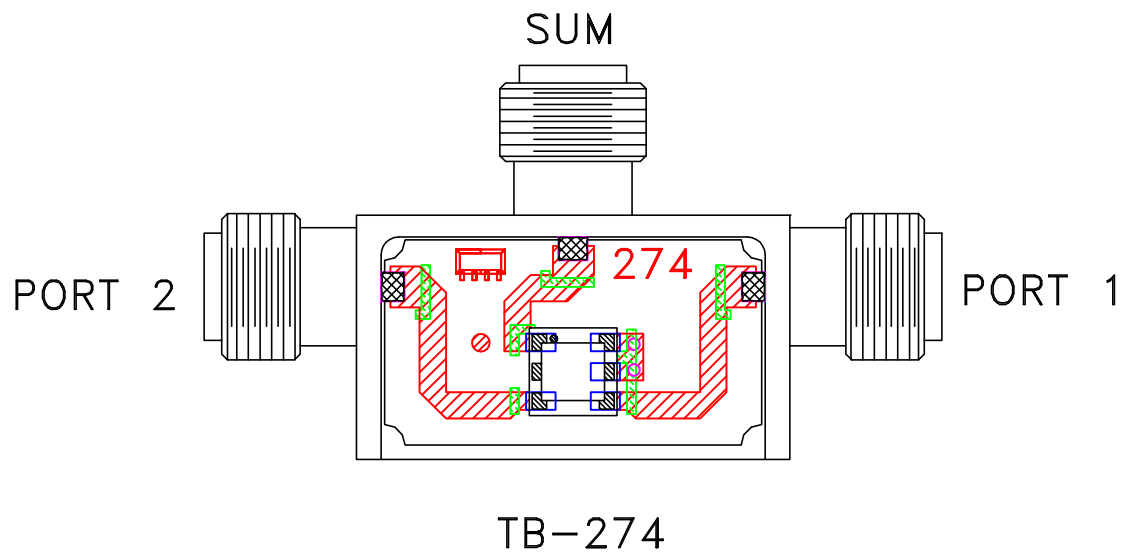

Notes:

1. SMA Female connectors.
2. PCB Material: Rogers R04350 or equivalent,
Dielectric Constant=3.5, Thickness=.020 inch.

 **Mini-Circuits®**

All Mini-Circuits products are manufactured under exacting quality assurance and control standards, and are capable of meeting published specifications after being subjected to any or all of the following physical and environmental test.

Specification	Test/Inspection Condition	Reference/Spec
Operating Temperature	-40° to 85°C Ambient Environment	Individual Model Data Sheet
Storage Temperature	-55° to 100° C Ambient Environment	Individual Model Data Sheet
Humidity	90 to 95% RH, 240 hours, 50°C	MIL-STD-202, Method 103, Condition A, Except 50°C and end-point electrical test done within 12 hours
Thermal Shock	-55° to 100°C, 100 cycles	MIL-STD-202, Method 107, Condition A-3, except +100°C
Solder Reflow Heat	Sn-Pb Eutetic Process: 225°C peak Pb-Free Process 245° - 250°C peak	J-STD-020, Table 4-1, 4-2 and 5-2, Figure 5-1
Solderability	10X Magnification	J-STD-002, 95% Coverage
Vibration (High Frequency)	20g peak, 10-2000 Hz, 12 times in each of three perpendicular directions (total 36)	MIL-STD-202, Method 204, Condition D
Mechanical Shock	50g, 11 ms, 1/2-sine, 18 shocks: 3 each direction, each of 3 axes	MIL-STD-202, Method 213, Condition A
Marking Resistance to Solvents	Isopropyl alcohol + mineral spirits at 25°C; terpene defluxer at 25°C; distilled water + proylene glycol monomethyl ether + monoethanolamine at 63°C to 70°C	MIL-STD-202, Method 215