



USB & RS232 & SPI

Programmable Attenuator

RUDAT-13G-60

50Ω

0.01 to 13 GHz

0 to 60 dB

0.5 dB step

SMA female

THE BIG DEAL

- Wide bandwidth, 10 MHz to 13 GHz
- Wide attenuation range, 60 dB
- USB control and automation
- RS232 and SPI for serial control compatibility

APPLICATIONS

- Test & measurement equipment / systems
- Transmission loss / fading simulators
- Communications, radar, EW, and ECM defense systems
- 5G FR1, WiFi 6E, UWB testing



Generic photo used for illustration purposes only.

PRODUCT OVERVIEW

Mini-Circuits' RUDAT-13G-60 is a general purpose, single channel programmable attenuator suitable for a wide range of signal level control applications from 10 MHz to 13 GHz. The attenuator provides 0 to 60 dB attenuation in 0.5 dB steps. Its unique design maintains linear attenuation change per dB, even at the highest attenuation settings.

The attenuator is housed in a compact, rugged metal case (3.75" x 2.0" x 0.68") with SMA (F) connectors on the bi-directional input and output RF ports, a 9-pin D-Sub connector and a USB type Mini-B receptacle for control and power.

Full software support is provided, including our user-friendly GUI application for Windows and a full API with programming instructions for Windows and Linux environments (both 32-bit and 64-bit systems).

KEY FEATURES

Feature	Advantages
USB control	USB HID interface provides easy compatibility with a wide range of software setups and programming environments.
RS232 and SPI control	Support for a wide range of straightforward serial control interfaces, without the overhead of a PC and operating system.
Programmable attenuation sweep and hop sequences	Configure automated signal fading and attenuation sequences to run without any external control.
Wide attenuation range	The module provides high-accuracy attenuation allowing the user precise level control over a broad attenuation range.

Trademarks:

Windows is a registered trademark of Microsoft Corporation in the United States and other countries ; Linux is a registered trademark of Linus Torvalds ; Pentium is a registered trademark of Intel Corporation. Neither Mini-Circuits nor the Mini-Circuits products are affiliated with or endorsed by the owners of the referenced trademarks. Mini-Circuits and the Mini-Circuits logo are registered trademarks of Scientific Components Corporation.



ELECTRICAL SPECIFICATIONS¹, 0 TO +50°C

Parameter	Conditions	Frequency (GHz)	Min.	Typ.	Max.	Unit
Attenuation range	0.5 dB step	0.01 - 13	0	-	60	dB
Attenuation accuracy ²	0.5 - 14 dB	0.01 - 0.5	-	±0.60	±(0.90 + 5.0% of Atten.)	dB
		0.5 - 5	-	±0.35	±(0.90 + 5.0% of Atten.)	
		5 - 11	-	±0.35	±(1.00 + 5.0% of Atten.)	
		11 - 13	-	±0.60	±(1.10 + 4.5% of Atten.)	
	14.5 - 60 dB	0.01 - 0.5	-	±0.65	±(1.45 + 1.0% of Atten.)	
		0.5 - 5	-	±0.60	±(1.30 + 2.0% of Atten.)	
		5 - 11	-	±0.60	±(1.35 + 2.5% of Atten.)	
		11 - 13	-	±0.70	±(1.35 + 2.5% of Atten.)	
Insertion loss	0 dB	0.01 - 0.5	-	4.8	6.5	dB
		0.5 - 5	-	6.0	9.5	
		5 - 11	-	7.8	12.0	
		11 - 13	-	10.4	14.0	
Isolation in-out ³	-	0.01 - 13	-	70	-	dB
Return loss	0 - 3.5 dB	0.01 - 0.5	-	11.0	-	dB
		0.5 - 5	-	14.5	-	
		5 - 11	-	14.5	-	
		11 - 13	-	14.5	-	
	4 - 45 dB	0.01 - 0.5	10.0	15.5	-	
		0.5 - 5	11.0	17.5	-	
		5 - 11	9.5	16.5	-	
		11 - 13	9.5	14.5	-	
	45.5 - 60 dB	0.01 - 0.5	11.5	23.0	-	
		0.5 - 5	12.0	23.0	-	
		5 - 11	9.5	16.5	-	
		11 - 13	9.5	14.5	-	

1. Attenuator RF ports support simultaneous, bi-directional signal transmission, within the specified power limits. However the specifications are guaranteed for the RF in and RF out as noted on the label. There may be minor changes in performance when injecting signals to the RF Out port.

2. Max accuracy defined as $\pm[\text{absolute error} + \% \text{ of attenuation setting}]$. For example, if a 20 dB attenuation at a given frequency is defined as max accuracy of " $\pm(0.5 + 3.0\%)$ " then the maximum error at those settings will be: $\pm(0.5 + 0.03 \times 20) = \pm(0.5 + 0.6) = \pm 1.1$ dB.

3. Isolation is defined as max attenuation plus insertion loss; this is the path loss through the attenuator when initially powered up. After a brief delay (~0.5 sec typically) the attenuator will revert to a user defined "power-up" state (either max attenuation or a pre-set value).

ELECTRICAL SPECIFICATIONS¹, 0 TO +50°C (CONTINUED)

Parameter	Conditions	Frequency (GHz)	Min.	Typ.	Max.	Unit
IP3 input ⁴	0 dB setting (P _{IN} = +5 dBm)	0.1 - 13	-	+41	-	dBm
Input operating power ^{1, 5}	0 - 60 dB	0.01 - 0.4	-	-	Note 6	dBm
		0.4 - 13	-	-	+23	
Attenuation transition time ⁷	-	0.01 - 13	-	900	-	ns
Minimum dwell time ⁸	High-speed mode	0.01 - 13	-	600	-	μs
Supply voltage (V _{cc})	-	-	4.75	5	5.25	V _{DC}
Supply current (I _{cc})	USB or D-Sub port	0 dB	-	150	190	mA
		60 dB	-	90	120	

4. Tested with 1 MHz span between signals. IP3 degrades below 100 MHz.

5. Total operating input power from both RF in and RF out ports. Compression level not noted as it exceeds max safe operating power level.

6. Derates linearly from +23 dBm at 400 MHz to +10 dBm at 10 MHz.

7. Attenuation transition time is specified as the time between starting to change the attenuation state and settling on the requested attenuation state.

8. Minimum dwell time is the minimum time the module will take between two attenuation changes.

ABSOLUTE MAXIMUM RATINGS⁹

Operating temperature	0°C to 50°C	
Storage temperature	-20°C to 85°C	
DC voltage at RF ports	16 V	
V _{USB} MAX	6 V	
Voltage input at D-Sub	Pin #1	-1 V to +6 V
	Pin #2	0 V to +4 V
	Pin #3	-30 V to +30 V
	Pin #6 - #9	0 V to +3.6V
Max RF power	0.01 - 0.4 GHz	Derates linearly from +25 dBm at 400 MHz to +13 dBm at 10 MHz.
	0.4 - 13 GHz	+25 dBm

9. Permanent damage may occur if any of these limits are exceeded. Operating in the range between operating power limits and absolute maximum ratings for extended periods of time may result in reduced life and reliability.



TYPICAL PERFORMANCE GRAPHS

Attenuation relative to Insertion Loss vs. Frequency @ 25°C

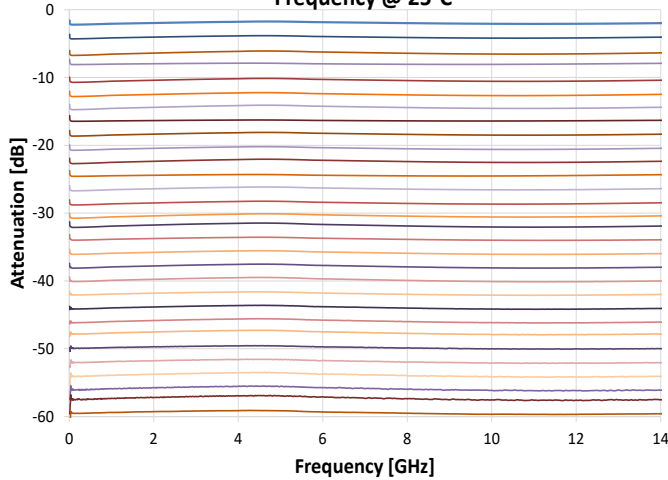

Insertion Loss vs. Frequency over Temperature

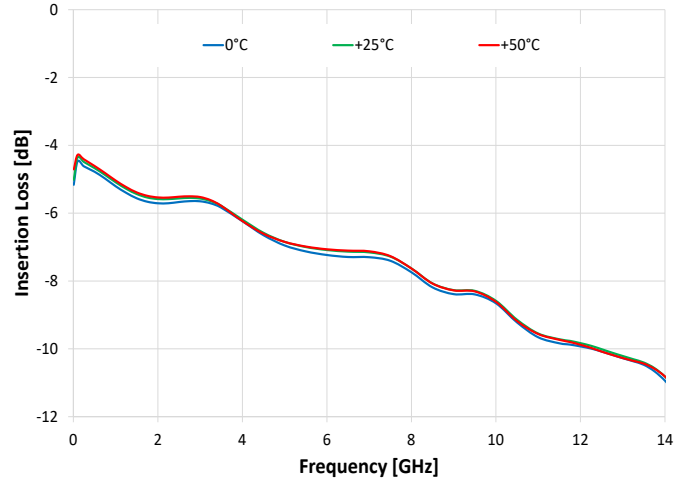

Attenuation Accuracy @ 25°C vs. Frequency over Attenuation settings

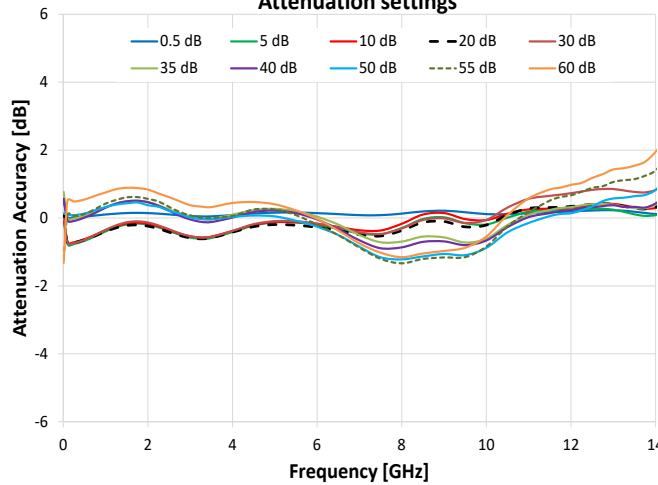

Attenuation Accuracy @ 0°C vs. Frequency over Attenuation settings

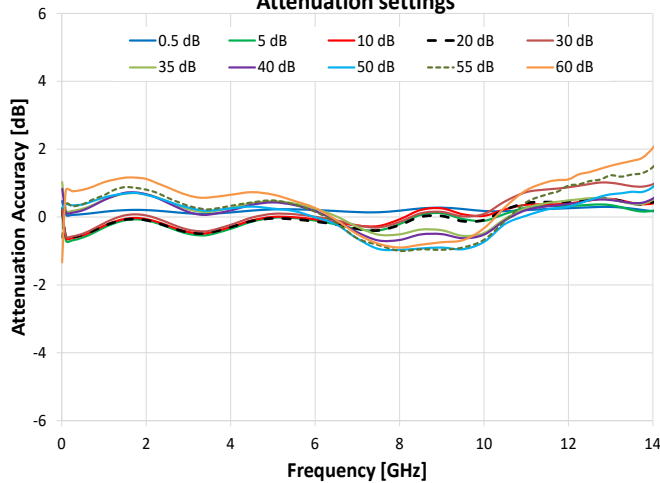

Attenuation Accuracy @ 50°C vs. Frequency over Attenuation settings

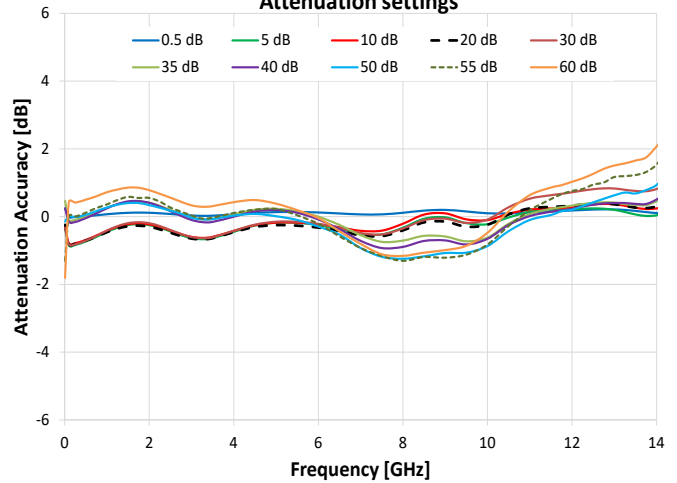



TYPICAL PERFORMANCE GRAPHS (CONTINUED)

Return Loss In vs. Frequency over Attenuation settings

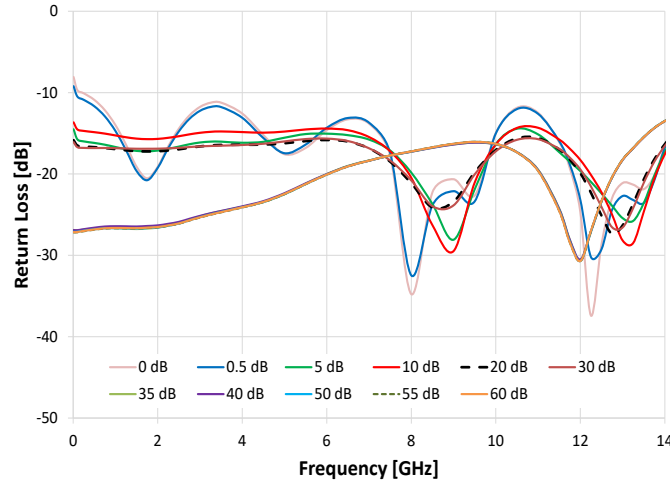

Return Loss Out vs. Frequency over Attenuation settings

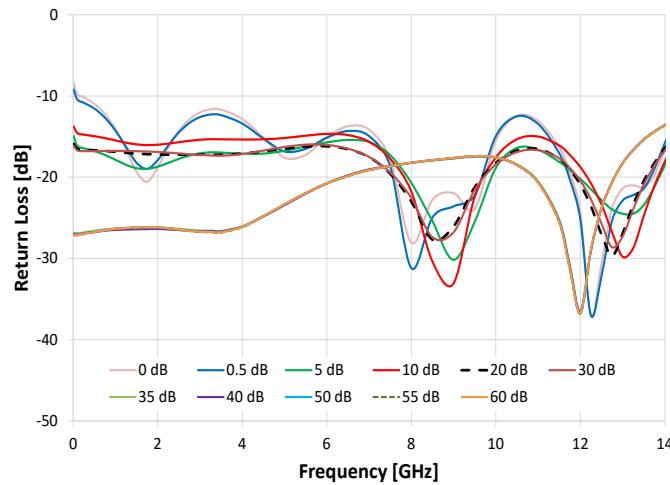



CONTROL INTERFACES

USB control	Protocol	HID (Human Interface Device) - Full-speed
	Min communication time ¹⁰	3 ms typ (full transmit/receive cycle)
RS232 control	Protocol	Meets RS232 standard at all voltages with RS232 communications set to 9600 bps; 8 bit word; no parity; stop bit = '1'.
SPI control	Protocol	See "SPI Communication Parameters" section

10. USB min communication time is based on the polling interval of the USB HID protocol (1 ms polling interval, 64 bytes per packet), medium CPU load and no other high speed USB devices using the USB bus.

SOFTWARE & DOCUMENTATION

Mini-Circuits' full software and support package including user guide, Windows GUI, API, programming manual and examples can be downloaded free of charge (refer to the last page for the download path).

A comprehensive set of software control options is provided:

- GUI for Windows – Simple software interface for control via Ethernet and USB.
- Programming / automation via USB:
 - DLL files provide a full API for Windows with a set of intuitive functions which can be implemented in any programming environment supporting .Net Framework or ActiveX.
 - Direct USB programming is possible in any other environment (not supporting .Net or ActiveX).

Please contact testsolutions@minicircuits.com for support.

MINIMUM SYSTEM REQUIREMENTS

GUI	Windows 7 or later
USB API DLL	Windows 7 or later and programming environment with ActiveX or .NET support
USB Direct Programming	Linux, Windows 7 or later
Hardware	Intel i3 (or equivalent) or later



GRAPHICAL USER INTERFACE (GUI) FOR WINDOWS - KEY FEATURES

- Connect via USB to control the module.
- Run GUI in "demo mode" to evaluate software without a hardware connection.

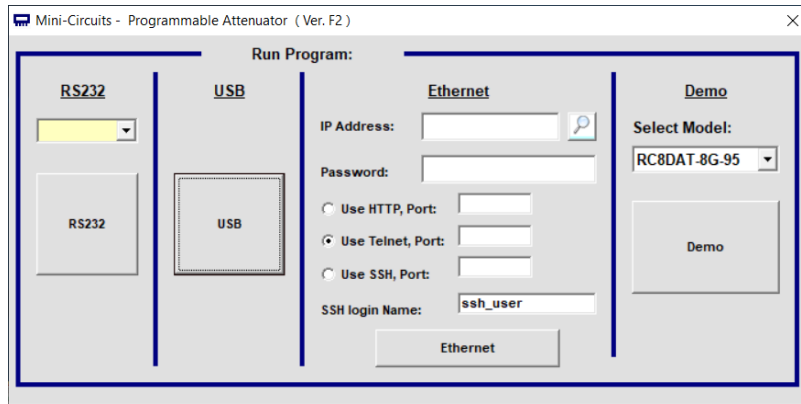

- Manual attenuation setting.
- Sweep and Hop attenuation sequences directed from the PC, or entire sequence loaded into the module.
- Attenuator address configuration and firmware upgrade.
- Attenuation at power up may be set to selected attenuation level or last attenuation state recorded.

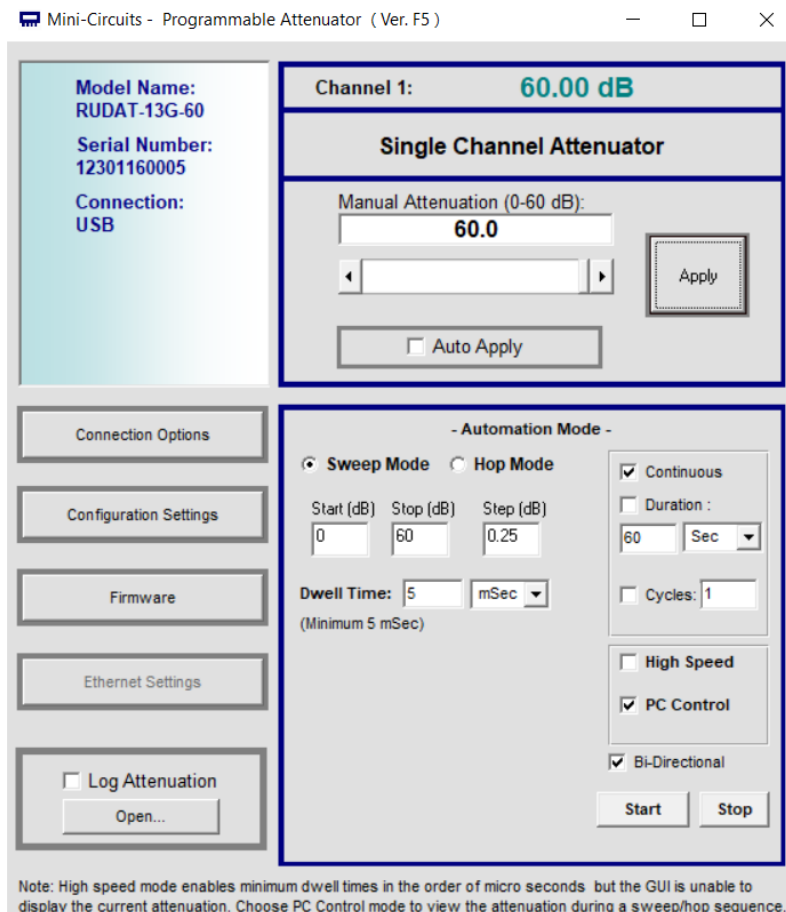



D-SUB PIN CONNECTIONS

The RS232 and SPI control options share the same D-Sub 9-pin connector so special attention must be paid to the requirements of both standards when designing a control cable.

Note in particular that RUDAT-13G models do not use the RS232 RTS (Ready to Send) function which is commonly implemented on pin #7 so it is important to disconnect this pin for RS232 control.

Pin #	RS232 control	SPI control
1	Optional +5 V _{DC} ¹¹	Optional +5 V _{DC} ¹¹
2	RS232 transmit (Tx)	Do not connect
3	RS232 receive (Rx)	Do not connect
4	Do not connect	Do not connect
5	Ground (GND)	Ground (GND)
6	Do not connect	Do not connect
7	Do not connect	SPI latch enable (LE)
8	Do not connect	SPI clock
9	Do not connect	SPI data in

11. Pin #1 can be used as supply voltage (+) pin instead of USB connection. When USB power is connected, pin #1 may be connected to GND or supply voltage (+) or remain disconnected.

RS232 CONTROL PINS

- Only pins #2 and #3 should be used for control.
- Pin #5 should be grounded.
- Pin #1 can optionally be used to provide the +5 V_{DC} supply (this could alternatively be provided via the USB port).
- All other pins must be disconnected in the control cable.

SPI CONTROL PINS

- Only pins #7, #8 and #9 should be used for control.
- Pin #5 should be grounded.
- Pin #1 can optionally be used to provide the +5 V_{DC} supply (this could alternatively be provided via the USB port).
- All other pins must be disconnected in the control cable.

Note: Pin connections marked in red (in the pin connection table) should not be connected to allow proper device operation.



SPI COMMUNICATIONS PARAMETERS

Parameter	Conditions		Min.	Typ.	Max.	Units
Voltage levels	Logic low voltage	Input	0	-	0.8	V
	Logic high voltage	Input	2.1	-	3.3	
Control current	Per pin		-	-	1.0	mA
Clock frequency	-		-	-	20	kHz

The SPI control used a 8-bit serial in, parallel-out shift register buffered by a transparent latch with Data, Clock, and Latch Enable (LE) voltages compatible with LVTTTL. The Data and Clock inputs allow data to be serially entered into the shift register, a process that is independent of the state of the LE input. The Value entered should be desired attenuation x 2, so for example to set attenuation level of 45.5 dB you will enter 91 decimal which is 0101 1011 in Binary.

The LE input controls the latch. When LE is HIGH, the latch is transparent and the contents of the serial shift register control the attenuator. When LE is brought LOW, data in the shift register is latched.

The shift register should be loaded while LE is held LOW to prevent the attenuation state from changing as data is entered. The LE input should then be toggled HIGH and brought LOW again, latching the new data. The timing for this operation is defined by the SPI Timing Diagram and SPI Interface AC Characteristics below.

SPI TIMING DIAGRAM

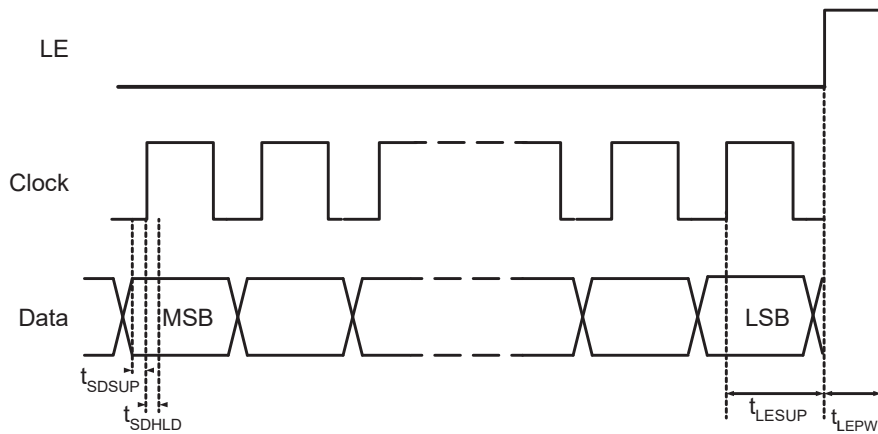

SPI INTERFACE AC CHARACTERISTICS

Symbol	Parameter	Min.	Max.	Units
f_{clk}	Serial data clock frequency	-	20	MHz
t_{clkH}	Serial clock HIGH time	10	-	ns
t_{clkL}	Serial clock LOW time	10	-	ns
t_{LESUP}	LE set-up time after last clock falling edge	30	-	ns
t_{LEPW}	LE minimum pulse width	20	-	ns
t_{SDSUP}	Serial data set-up time before clock rising edge	10	-	ns
t_{SDHLD}	Serial data hold time after clock falling edge	10	-	ns



PROGRAMMABLE ATTENUATOR RESPONSE TO COMMUNICATION INTERRUPT

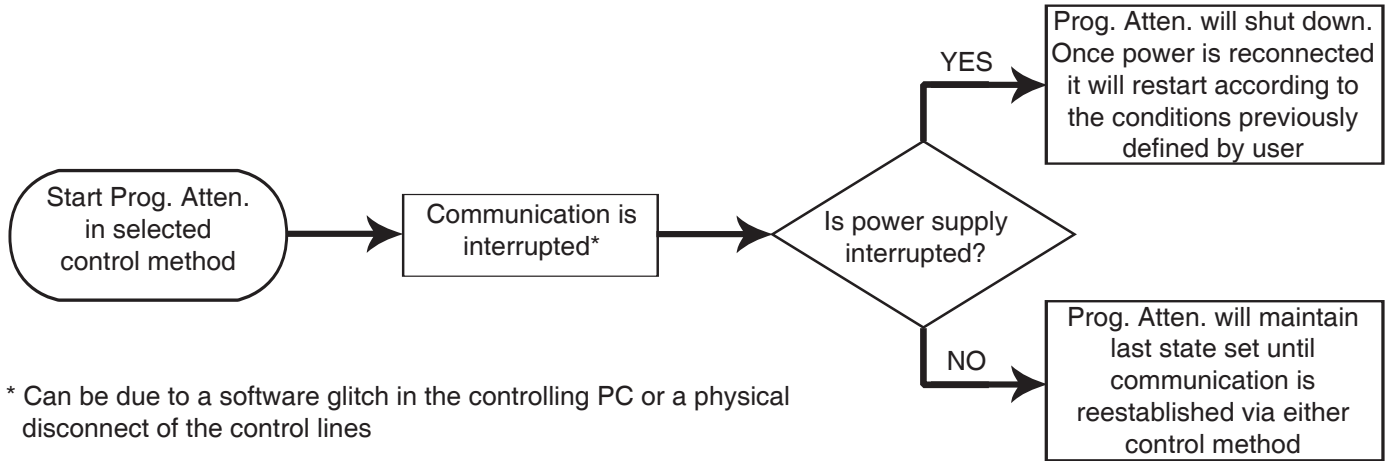

BLOCK DIAGRAM

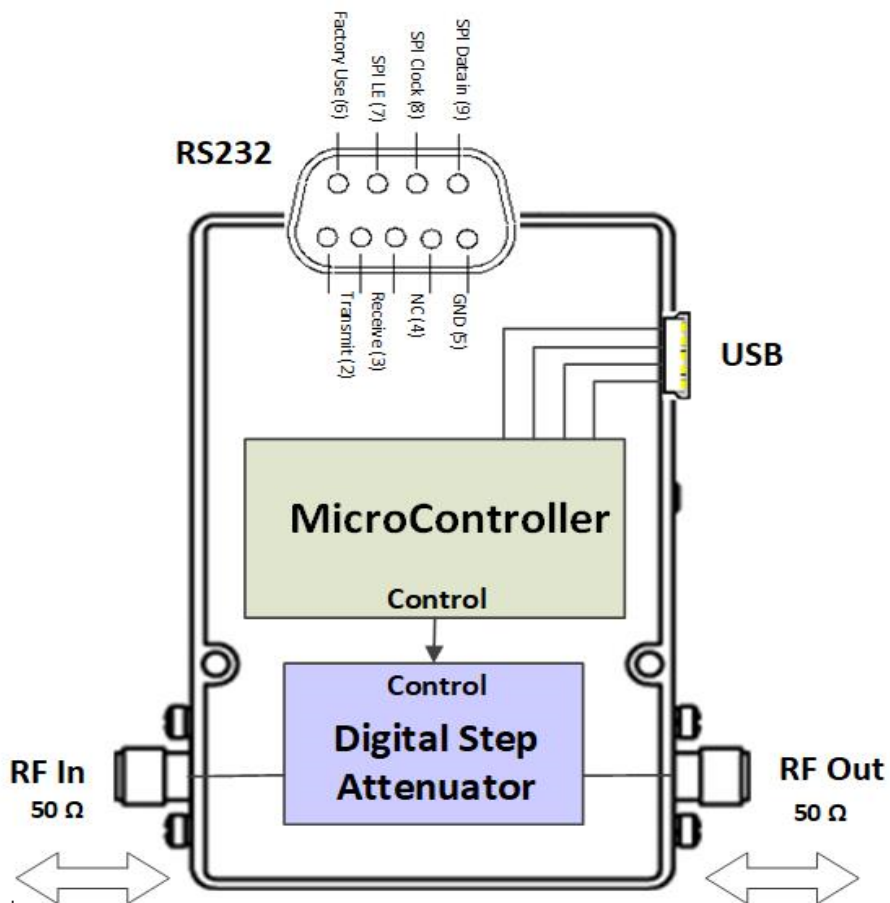

Simultaneous, bidirectional RF signal



CASE STYLE DRAWING (QF3370)

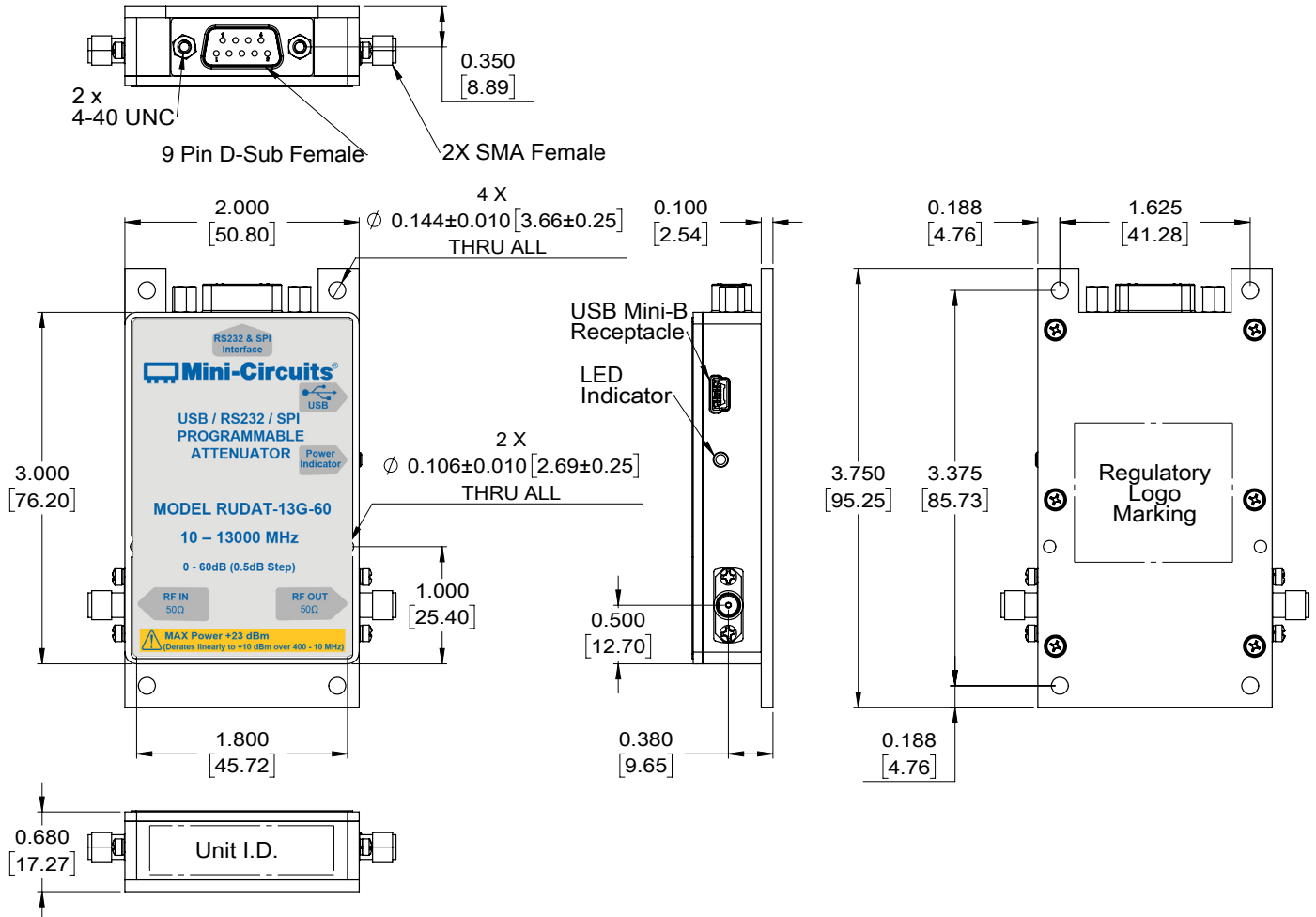

NOTES:

1. Case material: Aluminum alloy.
2. Case Finish: Nickel Plate.
3. Dimensions: Inches [mm]. Tolerances 2 Pl. ±.03 inch; 3 Pl. ±.015 inch.
4. Weight: 150 grams
5. Marking may contain other features or characters for internal lot control.

CONNECTIONS

Port Name	Connector Type
RF in & RF out	SMA female
USB	USB type Mini-B receptacle
RS232 & SPI	9-pin D-Sub female



RECOMMENDED ACCESSORIES

D-SUB9-MPT-3+ is an optional accessory cable for RS232 and SPI control. The cable has a D-Sub connector for mating to the module and bare wires (pig tail) on the other end allowing users to assemble their own cable with any connector they need. The cable is 36 inches (0.9 meter) long using 28 AWG wires.

CONTROL CABLE D-SUB9-MPT-3+

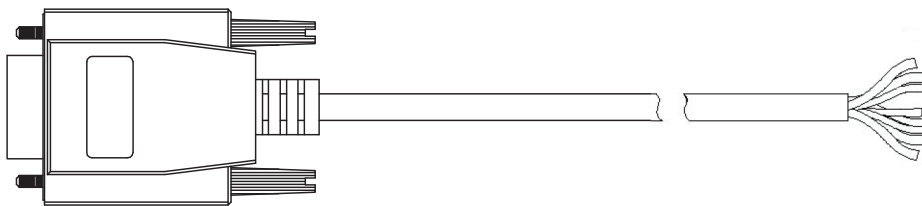

Pin number	When used for RS232 control		When used for SPI control		Pigtail wire color
	Function	Description	Function	Description	
1	Vcc	Supply voltage	Vcc	Supply voltage	BLACK
2	Tx	RS232 transmit	N/A	Do not connect	BROWN
3	Rx	RS232 receive	N/A	Do not connect	RED
4	N/A	Do not connect	N/A	Do not connect	ORANGE
5	GND	Ground connection	GND	Ground connection	YELLOW
6	N/A	Do not connect	N/A	Do not connect	GREEN
7	N/A	Do not connect	LE	SPI latch enable	BLUE
8	N/A	Do not connect	Clock	SPI clock	PURPLE
9	N/A	Do not connect	Data	SPI data in	WHITE





DETAILED MODEL INFORMATION IS AVAILABLE ON OUR WEBSITE

Performance Data & Graphs	Data Graphs
Case Style	QF3370
Environmental Rating	ENV55T1
Software, User Guide & Programming Manual	https://www.minicircuits.com/softwaredownload/sg.html
Regulatory Compliance	<p>Refer to user guide for compliance information</p>  https://www.minicircuits.com/app/AN49-005.pdf
Support	testsolutions@minicircuits.com

INCLUDED ACCESSORIES

	Qty.	Part No.	Description
	1	MUSB-CBL-3+	3.3 ft (1.0 m) USB Cable: USB type A (Male) to USB type Mini-B (Male)

OPTIONAL ACCESSORIES

	Part No.	Description
	MUSB-CBL-3+ (Spare)	3.3 ft (1.0 m) USB Cable: USB type A (Male) to USB type Mini-B (Male)
	MUSB-CBL-7+	6.6 ft (2.0 m) USB Cable: USB type A (Male) to USB type Mini-B (Male)
See page 12	D-SUB9-MPT-3+	3.0 ft (1.0 m) I ² C Cable: 9 pin D-sub (Male) to Pig-Tail (Bare wires)
	USB-AC/DC-5	AC/DC +5V power adaptor with USB connector ^{12, 13}

12. Not used in USB control. USB-AC/DC-5 can be used to provide the 5V_{DC} power when control is via RS232 or SPI; units can also accept DC supply voltage at Pin#1 of the D-Sub connector.

13. Includes power plugs for US, UK, EU, IL, AU & China. Plugs for other countries are also available. If you need a power cord for a country not listed please contact testsolutions@minicircuits.com

NOTES:

- Performance and quality attributes and conditions not expressly stated in this specification document are intended to be excluded and do not form a part of this specification document.
- Electrical specifications and performance data contained in this specification document are based on Mini-Circuit's applicable established test performance criteria and measurement instructions.
- The parts covered by this specification document are subject to Mini-Circuits standard limited warranty and terms and conditions (collectively, "Standard Terms"); Purchasers of this part are entitled to the rights and benefits contained therein. For a full statement of the Standard Terms and the exclusive rights and remedies thereunder, please visit Mini-Circuits' website at <https://www.minicircuits.com/terms/viewterm.html>

Programmable Attenuator RUDAT-13G-60

Typical Performance Data @ 0°C

FREQUENCY (MHz)	Attenuation relative to Insertion Loss (dB)							
	0.5 dB	10 dB	15 dB	20 dB	30 dB	40 dB	50 dB	60 dB
15	0.37	10.05	15.68	20.28	30.41	39.19	49.39	59.87
20	0.39	10.12	15.76	20.37	30.50	39.24	49.47	59.85
50	0.42	10.20	15.83	20.46	30.57	39.33	49.45	59.23
100	0.43	10.23	15.86	20.48	30.61	39.39	49.49	59.29
200	0.43	10.24	15.87	20.48	30.61	39.38	49.51	59.31
500	0.41	10.19	15.78	20.44	30.53	39.32	49.45	59.28
750	0.37	10.07	15.62	20.32	30.39	39.19	49.33	59.15
1000	0.33	9.93	15.43	20.18	30.22	39.04	49.17	58.97
1500	0.27	9.75	15.16	19.99	30.00	38.85	48.97	58.81
2000	0.26	9.76	15.18	20.01	30.04	38.91	49.04	58.91
2500	0.32	9.93	15.43	20.20	30.32	39.19	49.33	59.19
3000	0.37	10.02	15.62	20.30	30.53	39.39	49.54	59.40
3500	0.38	9.97	15.60	20.23	30.52	39.39	49.58	59.48
4000	0.32	9.73	15.33	19.99	30.28	39.22	49.37	59.29
4500	0.25	9.54	15.03	19.79	30.03	39.09	49.24	59.24
5000	0.20	9.44	14.85	19.71	29.91	39.06	49.18	59.21
5500	0.18	9.44	14.81	19.72	29.92	39.14	49.30	59.43
6000	0.19	9.50	14.92	19.79	30.07	39.38	49.55	59.82
6500	0.23	9.63	15.13	19.94	30.31	39.67	49.91	60.30
7000	0.28	9.75	15.35	20.10	30.61	40.01	50.30	60.79
7500	0.32	9.91	15.56	20.32	30.90	40.33	50.74	61.34
8000	0.30	9.81	15.46	20.26	30.94	40.39	50.93	61.61
8500	0.24	9.64	15.22	20.09	30.79	40.27	50.84	61.50
9000	0.20	9.51	15.08	19.93	30.68	40.10	50.73	61.10
9500	0.23	9.51	15.12	19.91	30.69	40.04	50.67	60.82
10000	0.28	9.35	15.04	19.69	30.51	39.81	50.35	60.26
10500	0.29	9.12	14.82	19.38	30.18	39.44	49.91	59.66
11000	0.25	9.00	14.65	19.19	29.91	39.25	49.53	59.23
11500	0.21	9.11	14.65	19.28	29.86	39.30	49.44	59.10
12000	0.17	9.15	14.56	19.31	29.71	39.29	49.14	58.87
12500	0.12	9.14	14.37	19.26	29.46	39.12	48.85	58.48
13000	0.06	9.03	14.14	19.09	29.11	38.77	48.49	58.17

Notes

- A. Performance and quality attributes and conditions not expressly stated in this specification document are intended to be excluded and do not form a part of this specification document.
- B. Electrical specifications and performance data contained in this specification document are based on Mini-Circuits' applicable established test performance criteria and measurement instructions.
- C. The parts covered by this specification document are subject to Mini-Circuits' standard limited warranty and terms and conditions (collectively, "Standard Terms"). Purchasers of this part are entitled to the rights and benefits contained therein. For a full statement of the Standard Terms and the exclusive rights and remedies thereunder, please visit Mini-Circuits' website at www.minicircuits.com/MCLStore/terms.jsp



Programmable Attenuator

RUDAT-13G-60

Typical Performance Data @ 0°C

FREQUENCY (MHz)	Attenuation accuracy relative to nominal attenuation setting (dB)							
	0.5 dB	10 dB	15 dB	20 dB	30 dB	40 dB	50 dB	60 dB
15	0.13	-0.05	-0.68	-0.28	-0.41	0.81	0.61	0.13
20	0.11	-0.12	-0.76	-0.37	-0.50	0.76	0.53	0.15
50	0.08	-0.20	-0.83	-0.46	-0.57	0.67	0.55	0.77
100	0.07	-0.23	-0.86	-0.48	-0.60	0.61	0.51	0.71
200	0.07	-0.24	-0.86	-0.48	-0.61	0.62	0.49	0.69
500	0.09	-0.19	-0.78	-0.44	-0.53	0.68	0.55	0.72
750	0.13	-0.07	-0.62	-0.32	-0.39	0.81	0.67	0.85
1000	0.17	0.07	-0.43	-0.18	-0.22	0.96	0.83	1.03
1500	0.23	0.25	-0.16	0.01	0.00	1.15	1.04	1.19
2000	0.24	0.24	-0.18	-0.01	-0.04	1.09	0.96	1.10
2500	0.18	0.07	-0.43	-0.19	-0.32	0.81	0.67	0.81
3000	0.13	-0.02	-0.62	-0.30	-0.53	0.61	0.46	0.60
3500	0.12	0.03	-0.60	-0.23	-0.52	0.61	0.42	0.52
4000	0.18	0.27	-0.33	0.01	-0.28	0.78	0.63	0.71
4500	0.25	0.47	-0.03	0.21	-0.03	0.92	0.76	0.76
5000	0.30	0.56	0.15	0.29	0.09	0.94	0.82	0.79
5500	0.32	0.56	0.19	0.28	0.08	0.86	0.70	0.57
6000	0.31	0.50	0.08	0.21	-0.07	0.63	0.45	0.18
6500	0.27	0.37	-0.13	0.06	-0.31	0.33	0.10	-0.29
7000	0.22	0.25	-0.35	-0.10	-0.61	-0.01	-0.30	-0.78
7500	0.18	0.09	-0.56	-0.32	-0.90	-0.33	-0.74	-1.34
8000	0.20	0.19	-0.46	-0.26	-0.94	-0.39	-0.93	-1.61
8500	0.26	0.36	-0.22	-0.09	-0.79	-0.27	-0.84	-1.50
9000	0.30	0.49	-0.08	0.07	-0.68	-0.10	-0.73	-1.10
9500	0.27	0.49	-0.12	0.09	-0.69	-0.04	-0.67	-0.82
10000	0.22	0.65	-0.04	0.31	-0.51	0.19	-0.35	-0.26
10500	0.21	0.88	0.18	0.62	-0.18	0.56	0.09	0.34
11000	0.25	1.00	0.35	0.81	0.09	0.75	0.47	0.77
11500	0.29	0.89	0.35	0.72	0.14	0.70	0.56	0.90
12000	0.33	0.85	0.44	0.69	0.29	0.71	0.86	1.13
12500	0.38	0.86	0.63	0.74	0.54	0.88	1.15	1.52
13000	0.44	0.97	0.86	0.91	0.89	1.23	1.51	1.83

Notes

- A. Performance and quality attributes and conditions not expressly stated in this specification document are intended to be excluded and do not form a part of this specification document.
- B. Electrical specifications and performance data contained in this specification document are based on Mini-Circuits' applicable established test performance criteria and measurement instructions.
- C. The parts covered by this specification document are subject to Mini-Circuits' standard limited warranty and terms and conditions (collectively, "Standard Terms"). Purchasers of this part are entitled to the rights and benefits contained therein. For a full statement of the Standard Terms and the exclusive rights and remedies thereunder, please visit Mini-Circuits' website at www.minicircuits.com/MCLStore/terms.jsp



Programmable Attenuator RUDAT-13G-60

Typical Performance Data @ 0°C

FREQUENCY (MHz)	Input VSWR (:1)							
	0.5 dB	10 dB	15 dB	20 dB	30 dB	40 dB	50 dB	60 dB
15	2.22	1.64	1.52	1.43	1.41	1.11	1.10	1.10
20	2.19	1.63	1.52	1.43	1.40	1.11	1.10	1.10
50	2.05	1.60	1.49	1.41	1.39	1.11	1.10	1.10
100	2.01	1.59	1.49	1.41	1.39	1.11	1.11	1.11
200	1.98	1.59	1.49	1.42	1.40	1.12	1.12	1.12
500	1.84	1.53	1.45	1.39	1.38	1.11	1.11	1.11
750	1.70	1.49	1.43	1.38	1.37	1.11	1.11	1.11
1000	1.55	1.45	1.41	1.36	1.36	1.11	1.10	1.10
1500	1.33	1.39	1.38	1.35	1.36	1.10	1.10	1.10
2000	1.34	1.39	1.37	1.34	1.36	1.10	1.10	1.10
2500	1.53	1.43	1.40	1.35	1.36	1.10	1.10	1.10
3000	1.73	1.50	1.44	1.38	1.37	1.12	1.11	1.11
3500	1.80	1.55	1.48	1.41	1.40	1.14	1.14	1.14
4000	1.66	1.53	1.48	1.42	1.41	1.17	1.16	1.16
4500	1.44	1.47	1.45	1.41	1.42	1.19	1.18	1.18
5000	1.28	1.41	1.43	1.39	1.42	1.20	1.20	1.20
5500	1.31	1.41	1.44	1.39	1.42	1.22	1.22	1.22
6000	1.46	1.45	1.47	1.39	1.41	1.25	1.24	1.24
6500	1.59	1.49	1.47	1.38	1.38	1.27	1.27	1.27
7000	1.58	1.45	1.42	1.33	1.32	1.28	1.28	1.28
7500	1.40	1.33	1.32	1.25	1.24	1.29	1.29	1.29
8000	1.16	1.16	1.18	1.15	1.15	1.31	1.31	1.31
8500	1.10	1.01	1.04	1.08	1.09	1.32	1.32	1.32
9000	1.19	1.14	1.10	1.16	1.15	1.33	1.33	1.33
9500	1.34	1.29	1.26	1.28	1.28	1.34	1.34	1.34
10000	1.65	1.46	1.42	1.40	1.40	1.34	1.34	1.34
10500	1.85	1.62	1.57	1.50	1.49	1.32	1.32	1.32
11000	1.75	1.67	1.63	1.55	1.53	1.29	1.29	1.29
11500	1.49	1.58	1.60	1.51	1.52	1.26	1.26	1.26
12000	1.27	1.45	1.52	1.44	1.47	1.28	1.28	1.28
12500	1.27	1.38	1.45	1.38	1.41	1.35	1.35	1.35
13000	1.46	1.38	1.40	1.35	1.35	1.45	1.45	1.45

Notes

- A. Performance and quality attributes and conditions not expressly stated in this specification document are intended to be excluded and do not form a part of this specification document.
- B. Electrical specifications and performance data contained in this specification document are based on Mini-Circuits' applicable established test performance criteria and measurement instructions.
- C. The parts covered by this specification document are subject to Mini-Circuits' standard limited warranty and terms and conditions (collectively, "Standard Terms"); Purchasers of this part are entitled to the rights and benefits contained therein. For a full statement of the Standard Terms and the exclusive rights and remedies thereunder, please visit Mini-Circuits' website at www.minicircuits.com/MCLStore/terms.jsp



Programmable Attenuator RUDAT-13G-60

Typical Performance Data @ 0°C

FREQUENCY (MHz)	Output VSWR (:1)							
	0.5 dB	10 dB	15 dB	20 dB	30 dB	40 dB	50 dB	60 dB
15	2.09	1.20	1.37	1.17	1.52	1.42	1.23	1.19
20	2.06	1.19	1.36	1.17	1.50	1.41	1.22	1.19
50	2.00	1.18	1.35	1.16	1.48	1.40	1.21	1.19
100	1.97	1.18	1.35	1.16	1.48	1.40	1.21	1.19
200	1.95	1.18	1.35	1.17	1.49	1.41	1.22	1.20
500	1.82	1.15	1.33	1.15	1.46	1.38	1.20	1.18
750	1.68	1.14	1.33	1.14	1.45	1.38	1.19	1.17
1000	1.55	1.12	1.33	1.13	1.45	1.37	1.19	1.17
1500	1.35	1.11	1.32	1.13	1.44	1.36	1.18	1.17
2000	1.35	1.10	1.31	1.12	1.41	1.34	1.17	1.16
2500	1.54	1.12	1.31	1.12	1.41	1.35	1.18	1.16
3000	1.78	1.18	1.34	1.16	1.44	1.39	1.21	1.20
3500	1.76	1.15	1.29	1.13	1.40	1.35	1.18	1.17
4000	1.67	1.17	1.33	1.17	1.43	1.39	1.21	1.22
4500	1.44	1.12	1.30	1.15	1.40	1.37	1.19	1.22
5000	1.28	1.12	1.31	1.17	1.40	1.39	1.21	1.25
5500	1.21	1.11	1.27	1.16	1.36	1.36	1.18	1.24
6000	1.35	1.19	1.31	1.21	1.39	1.41	1.22	1.30
6500	1.41	1.19	1.22	1.19	1.30	1.34	1.15	1.26
7000	1.56	1.25	1.27	1.25	1.34	1.39	1.20	1.33
7500	1.35	1.26	1.19	1.28	1.21	1.29	1.18	1.33
8000	1.20	1.15	1.08	1.18	1.11	1.18	1.09	1.22
8500	1.05	1.27	1.14	1.30	1.10	1.15	1.23	1.29
9000	1.18	1.26	1.21	1.26	1.18	1.10	1.28	1.17
9500	1.28	1.29	1.29	1.29	1.24	1.16	1.34	1.18
10000	1.74	1.45	1.51	1.38	1.45	1.37	1.48	1.27
10500	1.85	1.41	1.47	1.30	1.42	1.37	1.41	1.23
11000	1.99	1.52	1.61	1.42	1.61	1.59	1.52	1.41
11500	1.52	1.26	1.38	1.24	1.44	1.49	1.30	1.34
12000	1.37	1.23	1.37	1.26	1.46	1.54	1.31	1.41
12500	1.20	1.31	1.32	1.40	1.47	1.58	1.32	1.58
13000	1.25	1.28	1.16	1.30	1.24	1.33	1.19	1.39

Notes

- A. Performance and quality attributes and conditions not expressly stated in this specification document are intended to be excluded and do not form a part of this specification document.
- B. Electrical specifications and performance data contained in this specification document are based on Mini-Circuits' applicable established test performance criteria and measurement instructions.
- C. The parts covered by this specification document are subject to Mini-Circuits' standard limited warranty and terms and conditions (collectively, "Standard Terms"). Purchasers of this part are entitled to the rights and benefits contained therein. For a full statement of the Standard Terms and the exclusive rights and remedies thereunder, please visit Mini-Circuits' website at www.minicircuits.com/MCLStore/terms.jsp



Programmable Attenuator RUDAT-13G-60

Typical Performance Data @ 0°C

FREQUENCY (MHz)	IP3 (dBm)	Insertion Loss @P _{IN} =0 dBm (dB)	Insertion Loss @P _{IN} =+23 dBm (dB)
10	22.51	4.72	5.77
50	35.25	4.15	4.23
100	39.19	5.09	5.13
200	40.40	5.14	5.16
500	40.47	4.99	5.07
1000	40.42	5.00	5.06
2000	40.02	6.02	6.10
3000	39.31	5.89	5.99
4000	40.12	6.80	6.81
5000	40.59	7.82	7.84
6000	41.17	7.90	7.89
7000	39.04	7.75	7.72
8000	40.40	7.96	7.94
9000	39.07	8.62	8.80
10000	40.46	9.05	9.19
11000	41.03	9.64	9.84
12000	41.37	10.28	10.46
13000	41.17	11.18	11.32

Notes

- A. Performance and quality attributes and conditions not expressly stated in this specification document are intended to be excluded and do not form a part of this specification document.
B. Electrical specifications and performance data contained in this specification document are based on Mini-Circuits' applicable established test performance criteria and measurement instructions.
C. The parts covered by this specification document are subject to Mini-Circuits' standard limited warranty and terms and conditions (collectively, "Standard Terms"); Purchasers of this part are entitled to the rights and benefits contained therein. For a full statement of the Standard Terms and the exclusive rights and remedies thereunder, please visit Mini-Circuits' website at www.minicircuits.com/MCLStore/terms.jsp



Programmable Attenuator RUDAT-13G-60

Typical Performance Data @ +25°C

FREQUENCY (MHz)	Attenuation relative to Insertion Loss (dB)							
	0.5 dB	10 dB	15 dB	20 dB	30 dB	40 dB	50 dB	60 dB
15	0.34	10.18	15.85	20.47	30.67	39.47	49.69	59.85
20	0.38	10.25	15.91	20.54	30.76	39.50	49.76	59.87
50	0.42	10.33	16.00	20.64	30.85	39.60	49.76	59.61
100	0.44	10.37	16.04	20.68	30.90	39.66	49.84	59.69
200	0.45	10.39	16.05	20.70	30.92	39.68	49.87	59.69
500	0.43	10.32	15.95	20.63	30.84	39.60	49.79	59.66
750	0.40	10.22	15.80	20.52	30.70	39.49	49.67	59.54
1000	0.36	10.10	15.63	20.40	30.55	39.33	49.54	59.39
1500	0.31	9.93	15.38	20.22	30.35	39.16	49.35	59.22
2000	0.31	9.94	15.40	20.25	30.40	39.24	49.43	59.28
2500	0.36	10.09	15.64	20.42	30.66	39.48	49.69	59.58
3000	0.40	10.19	15.82	20.51	30.86	39.69	49.91	59.81
3500	0.41	10.09	15.77	20.41	30.81	39.66	49.90	59.80
4000	0.36	9.88	15.51	20.18	30.59	39.51	49.71	59.63
4500	0.30	9.71	15.25	20.02	30.37	39.39	49.60	59.59
5000	0.25	9.64	15.10	19.96	30.28	39.39	49.59	59.68
5500	0.24	9.65	15.07	19.98	30.30	39.49	49.70	59.85
6000	0.25	9.71	15.16	20.05	30.42	39.69	49.93	60.22
6500	0.29	9.81	15.35	20.17	30.65	39.96	50.26	60.66
7000	0.34	9.96	15.59	20.36	30.95	40.31	50.69	61.21
7500	0.37	10.06	15.75	20.51	31.22	40.62	51.07	61.72
8000	0.35	10.00	15.68	20.50	31.28	40.70	51.29	61.98
8500	0.30	9.81	15.44	20.30	31.12	40.54	51.18	61.85
9000	0.26	9.71	15.31	20.17	31.03	40.37	51.08	61.48
9500	0.29	9.71	15.36	20.14	31.03	40.31	50.98	61.11
10000	0.34	9.53	15.26	19.91	30.83	40.04	50.69	60.61
10500	0.34	9.27	15.00	19.56	30.45	39.66	50.17	59.95
11000	0.31	9.21	14.88	19.43	30.23	39.50	49.85	59.57
11500	0.28	9.31	14.88	19.52	30.18	39.58	49.72	59.37
12000	0.24	9.41	14.82	19.60	30.07	39.58	49.50	59.16
12500	0.19	9.36	14.61	19.50	29.77	39.33	49.11	58.78
13000	0.13	9.24	14.38	19.33	29.41	38.96	48.72	58.37

Notes

- A. Performance and quality attributes and conditions not expressly stated in this specification document are intended to be excluded and do not form a part of this specification document.
- B. Electrical specifications and performance data contained in this specification document are based on Mini-Circuits' applicable established test performance criteria and measurement instructions.
- C. The parts covered by this specification document are subject to Mini-Circuits' standard limited warranty and terms and conditions (collectively, "Standard Terms"). Purchasers of this part are entitled to the rights and benefits contained therein. For a full statement of the Standard Terms and the exclusive rights and remedies thereunder, please visit Mini-Circuits' website at www.minicircuits.com/MCLStore/terms.jsp



Programmable Attenuator

RUDAT-13G-60

Typical Performance Data @ +25°C

FREQUENCY (MHz)	Attenuation accuracy relative to nominal attenuation setting (dB)							
	0.5 dB	10 dB	15 dB	20 dB	30 dB	40 dB	50 dB	60 dB
15	0.16	-0.18	-0.85	-0.47	-0.67	0.53	0.31	0.15
20	0.12	-0.24	-0.91	-0.54	-0.76	0.51	0.24	0.13
50	0.08	-0.32	-0.99	-0.64	-0.85	0.40	0.24	0.39
100	0.06	-0.37	-1.04	-0.68	-0.90	0.34	0.16	0.31
200	0.05	-0.39	-1.05	-0.69	-0.92	0.33	0.13	0.31
500	0.07	-0.32	-0.95	-0.63	-0.84	0.40	0.21	0.34
750	0.11	-0.22	-0.80	-0.52	-0.70	0.51	0.33	0.46
1000	0.14	-0.10	-0.63	-0.40	-0.55	0.67	0.46	0.62
1500	0.19	0.07	-0.38	-0.22	-0.34	0.84	0.65	0.78
2000	0.19	0.06	-0.40	-0.25	-0.40	0.76	0.57	0.72
2500	0.15	-0.09	-0.64	-0.42	-0.66	0.52	0.31	0.42
3000	0.10	-0.19	-0.82	-0.51	-0.86	0.31	0.09	0.19
3500	0.09	-0.09	-0.77	-0.41	-0.81	0.34	0.10	0.20
4000	0.14	0.12	-0.51	-0.18	-0.59	0.49	0.29	0.38
4500	0.20	0.29	-0.25	-0.02	-0.37	0.61	0.40	0.41
5000	0.25	0.36	-0.10	0.04	-0.28	0.61	0.41	0.32
5500	0.26	0.35	-0.07	0.02	-0.30	0.51	0.30	0.15
6000	0.25	0.29	-0.16	-0.05	-0.42	0.31	0.07	-0.22
6500	0.21	0.19	-0.35	-0.17	-0.65	0.04	-0.26	-0.66
7000	0.17	0.04	-0.59	-0.36	-0.95	-0.31	-0.69	-1.21
7500	0.13	-0.06	-0.75	-0.51	-1.22	-0.62	-1.07	-1.72
8000	0.15	0.00	-0.68	-0.50	-1.28	-0.70	-1.29	-1.98
8500	0.20	0.19	-0.44	-0.30	-1.12	-0.54	-1.18	-1.85
9000	0.24	0.29	-0.31	-0.17	-1.03	-0.37	-1.08	-1.48
9500	0.21	0.30	-0.36	-0.14	-1.03	-0.31	-0.98	-1.11
10000	0.16	0.47	-0.26	0.09	-0.83	-0.03	-0.69	-0.61
10500	0.16	0.73	0.00	0.44	-0.45	0.34	-0.17	0.05
11000	0.19	0.79	0.12	0.57	-0.23	0.50	0.15	0.43
11500	0.22	0.69	0.12	0.48	-0.18	0.42	0.28	0.63
12000	0.26	0.59	0.18	0.40	-0.07	0.42	0.50	0.84
12500	0.31	0.64	0.39	0.50	0.23	0.67	0.89	1.22
13000	0.37	0.76	0.62	0.67	0.59	1.04	1.28	1.63

Notes

- A. Performance and quality attributes and conditions not expressly stated in this specification document are intended to be excluded and do not form a part of this specification document.
- B. Electrical specifications and performance data contained in this specification document are based on Mini-Circuits' applicable established test performance criteria and measurement instructions.
- C. The parts covered by this specification document are subject to Mini-Circuits' standard limited warranty and terms and conditions (collectively, "Standard Terms"). Purchasers of this part are entitled to the rights and benefits contained therein. For a full statement of the Standard Terms and the exclusive rights and remedies thereunder, please visit Mini-Circuits' website at www.minicircuits.com/MCLStore/terms.jsp



Programmable Attenuator RUDAT-13G-60

Typical Performance Data @ +25°C

FREQUENCY (MHz)	Input VSWR (:1)							
	0.5 dB	10 dB	15 dB	20 dB	30 dB	40 dB	50 dB	60 dB
15	2.08	1.61	1.50	1.42	1.39	1.10	1.10	1.10
20	2.05	1.60	1.49	1.41	1.38	1.10	1.10	1.10
50	1.99	1.58	1.47	1.40	1.38	1.10	1.10	1.10
100	1.96	1.57	1.47	1.39	1.37	1.10	1.10	1.10
200	1.93	1.56	1.46	1.39	1.37	1.10	1.10	1.10
500	1.81	1.52	1.44	1.38	1.37	1.10	1.10	1.10
750	1.68	1.49	1.42	1.37	1.36	1.10	1.10	1.10
1000	1.54	1.45	1.40	1.36	1.36	1.10	1.10	1.10
1500	1.31	1.38	1.37	1.34	1.35	1.10	1.09	1.09
2000	1.32	1.38	1.37	1.33	1.34	1.09	1.09	1.09
2500	1.52	1.43	1.40	1.35	1.35	1.10	1.10	1.10
3000	1.73	1.50	1.44	1.38	1.37	1.12	1.12	1.12
3500	1.77	1.54	1.47	1.40	1.39	1.14	1.14	1.14
4000	1.63	1.53	1.48	1.42	1.42	1.18	1.17	1.17
4500	1.44	1.48	1.47	1.42	1.43	1.20	1.19	1.19
5000	1.30	1.43	1.46	1.42	1.44	1.22	1.22	1.22
5500	1.32	1.42	1.45	1.40	1.43	1.23	1.23	1.23
6000	1.47	1.46	1.48	1.40	1.41	1.25	1.25	1.25
6500	1.58	1.48	1.47	1.37	1.37	1.26	1.26	1.26
7000	1.57	1.44	1.42	1.32	1.31	1.27	1.27	1.27
7500	1.40	1.33	1.33	1.25	1.25	1.29	1.29	1.29
8000	1.15	1.16	1.18	1.14	1.14	1.29	1.29	1.29
8500	1.10	1.01	1.04	1.07	1.07	1.30	1.31	1.31
9000	1.18	1.14	1.10	1.15	1.14	1.32	1.33	1.33
9500	1.33	1.28	1.25	1.27	1.26	1.33	1.33	1.33
10000	1.66	1.46	1.42	1.40	1.39	1.34	1.34	1.34
10500	1.86	1.62	1.57	1.51	1.49	1.33	1.32	1.32
11000	1.70	1.64	1.61	1.52	1.51	1.27	1.27	1.27
11500	1.48	1.59	1.61	1.52	1.53	1.27	1.27	1.27
12000	1.26	1.44	1.51	1.43	1.46	1.27	1.27	1.27
12500	1.27	1.38	1.45	1.37	1.40	1.34	1.34	1.34
13000	1.48	1.40	1.42	1.36	1.37	1.45	1.45	1.45

Notes

- A. Performance and quality attributes and conditions not expressly stated in this specification document are intended to be excluded and do not form a part of this specification document.
- B. Electrical specifications and performance data contained in this specification document are based on Mini-Circuits' applicable established test performance criteria and measurement instructions.
- C. The parts covered by this specification document are subject to Mini-Circuits' standard limited warranty and terms and conditions (collectively, "Standard Terms"). Purchasers of this part are entitled to the rights and benefits contained therein. For a full statement of the Standard Terms and the exclusive rights and remedies thereunder, please visit Mini-Circuits' website at www.minicircuits.com/MCLStore/terms.jsp



Programmable Attenuator RUDAT-13G-60

Typical Performance Data @ +25°C

FREQUENCY (MHz)	Output VSWR (:1)							
	0.5 dB	10 dB	15 dB	20 dB	30 dB	40 dB	50 dB	60 dB
15	2.05	1.19	1.36	1.17	1.49	1.41	1.22	1.19
20	2.02	1.19	1.35	1.17	1.48	1.40	1.22	1.19
50	1.97	1.18	1.34	1.16	1.46	1.39	1.20	1.18
100	1.93	1.17	1.33	1.15	1.45	1.39	1.20	1.18
200	1.90	1.16	1.33	1.15	1.45	1.38	1.20	1.18
500	1.80	1.15	1.33	1.15	1.44	1.38	1.19	1.17
750	1.67	1.14	1.32	1.14	1.44	1.37	1.19	1.17
1000	1.54	1.12	1.32	1.13	1.43	1.37	1.18	1.17
1500	1.33	1.10	1.30	1.12	1.41	1.35	1.17	1.16
2000	1.35	1.10	1.30	1.12	1.40	1.34	1.17	1.16
2500	1.54	1.13	1.31	1.13	1.40	1.35	1.18	1.17
3000	1.74	1.16	1.32	1.15	1.41	1.36	1.19	1.18
3500	1.77	1.17	1.32	1.16	1.41	1.37	1.20	1.20
4000	1.64	1.17	1.32	1.18	1.42	1.39	1.21	1.23
4500	1.44	1.14	1.32	1.17	1.41	1.40	1.21	1.24
5000	1.28	1.14	1.32	1.18	1.41	1.40	1.22	1.26
5500	1.24	1.15	1.31	1.19	1.40	1.41	1.22	1.28
6000	1.32	1.18	1.28	1.20	1.37	1.39	1.20	1.29
6500	1.46	1.22	1.27	1.23	1.34	1.38	1.19	1.30
7000	1.51	1.23	1.23	1.24	1.28	1.35	1.16	1.30
7500	1.40	1.22	1.19	1.24	1.22	1.30	1.15	1.30
8000	1.16	1.19	1.11	1.23	1.12	1.20	1.14	1.26
8500	1.05	1.21	1.09	1.24	1.06	1.11	1.18	1.23
9000	1.13	1.25	1.18	1.26	1.14	1.07	1.27	1.19
9500	1.31	1.32	1.32	1.31	1.28	1.19	1.37	1.20
10000	1.70	1.42	1.47	1.35	1.41	1.33	1.45	1.25
10500	1.95	1.47	1.54	1.37	1.49	1.44	1.47	1.30
11000	1.89	1.46	1.55	1.36	1.54	1.54	1.46	1.37
11500	1.59	1.32	1.44	1.29	1.49	1.54	1.37	1.39
12000	1.30	1.22	1.35	1.29	1.46	1.56	1.30	1.46
12500	1.12	1.23	1.24	1.30	1.38	1.48	1.24	1.47
13000	1.31	1.34	1.23	1.37	1.31	1.39	1.26	1.46

Notes

- A. Performance and quality attributes and conditions not expressly stated in this specification document are intended to be excluded and do not form a part of this specification document.
- B. Electrical specifications and performance data contained in this specification document are based on Mini-Circuits' applicable established test performance criteria and measurement instructions.
- C. The parts covered by this specification document are subject to Mini-Circuits' standard limited warranty and terms and conditions (collectively, "Standard Terms"). Purchasers of this part are entitled to the rights and benefits contained therein. For a full statement of the Standard Terms and the exclusive rights and remedies thereunder, please visit Mini-Circuits' website at www.minicircuits.com/MCLStore/terms.jsp



Programmable Attenuator RUDAT-13G-60

Typical Performance Data @ +25°C

FREQUENCY (MHz)	IP3 (dBm)	Insertion Loss @P _{IN} =0 dBm (dB)	Insertion Loss @P _{IN} =+23 dBm (dB)
10	22.82	4.72	5.77
50	35.45	4.15	4.23
100	40.17	5.09	5.13
200	41.87	5.14	5.16
500	41.14	4.99	5.07
1000	40.40	5.00	5.06
2000	40.16	6.02	6.10
3000	40.24	5.89	5.99
4000	41.09	6.80	6.81
5000	40.72	7.82	7.84
6000	41.30	7.90	7.89
7000	41.01	7.75	7.72
8000	40.39	7.96	7.94
9000	40.70	8.62	8.80
10000	41.45	9.05	9.19
11000	42.67	9.64	9.84
12000	43.88	10.28	10.46
13000	42.61	11.18	11.32

Notes

- A. Performance and quality attributes and conditions not expressly stated in this specification document are intended to be excluded and do not form a part of this specification document.
B. Electrical specifications and performance data contained in this specification document are based on Mini-Circuits' applicable established test performance criteria and measurement instructions.
C. The parts covered by this specification document are subject to Mini-Circuits' standard limited warranty and terms and conditions (collectively, "Standard Terms"). Purchasers of this part are entitled to the rights and benefits contained therein. For a full statement of the Standard Terms and the exclusive rights and remedies thereunder, please visit Mini-Circuits' website at www.minicircuits.com/MCLStore/terms.jsp



Programmable Attenuator RUDAT-13G-60

Typical Performance Data @ +50°C

FREQUENCY (MHz)	Attenuation relative to Insertion Loss (dB)							
	0.5 dB	10 dB	15 dB	20 dB	30 dB	40 dB	50 dB	60 dB
15	0.45	10.33	16.00	20.62	30.90	39.60	49.92	60.01
20	0.47	10.38	16.05	20.68	30.95	39.63	49.95	60.02
50	0.49	10.44	16.11	20.76	31.02	39.73	49.89	59.72
100	0.50	10.47	16.14	20.79	31.06	39.77	49.96	59.82
200	0.50	10.49	16.16	20.81	31.08	39.79	49.99	59.82
500	0.48	10.41	16.04	20.72	30.97	39.69	49.90	59.76
750	0.45	10.30	15.90	20.62	30.85	39.57	49.77	59.64
1000	0.42	10.19	15.73	20.50	30.69	39.44	49.65	59.52
1500	0.37	10.02	15.49	20.33	30.49	39.26	49.47	59.34
2000	0.37	10.04	15.51	20.35	30.54	39.33	49.55	59.43
2500	0.42	10.20	15.74	20.52	30.80	39.60	49.82	59.74
3000	0.46	10.27	15.91	20.61	30.99	39.77	50.00	59.91
3500	0.46	10.17	15.85	20.50	30.94	39.74	50.00	59.94
4000	0.41	9.94	15.57	20.24	30.69	39.55	49.77	59.70
4500	0.36	9.80	15.34	20.11	30.50	39.46	49.68	59.64
5000	0.32	9.74	15.21	20.07	30.42	39.49	49.67	59.75
5500	0.31	9.75	15.17	20.08	30.43	39.59	49.80	59.96
6000	0.32	9.80	15.26	20.14	30.54	39.77	50.02	60.30
6500	0.35	9.92	15.45	20.28	30.77	40.05	50.38	60.83
7000	0.39	10.05	15.68	20.45	31.08	40.38	50.79	61.33
7500	0.42	10.16	15.85	20.62	31.35	40.72	51.17	61.79
8000	0.40	10.06	15.75	20.55	31.37	40.74	51.33	62.02
8500	0.35	9.89	15.52	20.38	31.22	40.59	51.24	61.86
9000	0.32	9.79	15.40	20.25	31.12	40.44	51.12	61.55
9500	0.35	9.78	15.44	20.22	31.13	40.35	51.06	61.19
10000	0.39	9.61	15.34	19.99	30.92	40.10	50.71	60.59
10500	0.39	9.36	15.09	19.64	30.55	39.70	50.25	59.99
11000	0.37	9.30	14.97	19.51	30.32	39.58	49.89	59.56
11500	0.34	9.42	14.99	19.64	30.29	39.66	49.78	59.42
12000	0.30	9.50	14.90	19.69	30.14	39.62	49.54	59.22
12500	0.25	9.46	14.70	19.60	29.86	39.38	49.13	58.82
13000	0.19	9.34	14.47	19.40	29.47	38.99	48.73	58.42

Notes

- A. Performance and quality attributes and conditions not expressly stated in this specification document are intended to be excluded and do not form a part of this specification document.
- B. Electrical specifications and performance data contained in this specification document are based on Mini-Circuits' applicable established test performance criteria and measurement instructions.
- C. The parts covered by this specification document are subject to Mini-Circuits' standard limited warranty and terms and conditions (collectively, "Standard Terms"). Purchasers of this part are entitled to the rights and benefits contained therein. For a full statement of the Standard Terms and the exclusive rights and remedies thereunder, please visit Mini-Circuits' website at www.minicircuits.com/MCLStore/terms.jsp



Programmable Attenuator

RUDAT-13G-60

Typical Performance Data @ +50°C

FREQUENCY (MHz)	Attenuation accuracy relative to nominal attenuation setting (dB)							
	0.5 dB	10 dB	15 dB	20 dB	30 dB	40 dB	50 dB	60 dB
15	0.05	-0.33	-1.00	-0.62	-0.90	0.40	0.08	-0.01
20	0.03	-0.38	-1.05	-0.68	-0.95	0.37	0.05	-0.02
50	0.01	-0.44	-1.11	-0.76	-1.02	0.28	0.11	0.28
100	0.00	-0.47	-1.14	-0.79	-1.06	0.23	0.04	0.18
200	0.00	-0.49	-1.16	-0.81	-1.08	0.21	0.01	0.18
500	0.02	-0.40	-1.04	-0.72	-0.97	0.31	0.10	0.24
750	0.05	-0.30	-0.90	-0.62	-0.84	0.44	0.23	0.36
1000	0.08	-0.19	-0.73	-0.50	-0.69	0.56	0.35	0.48
1500	0.13	-0.02	-0.48	-0.33	-0.49	0.74	0.53	0.66
2000	0.13	-0.04	-0.51	-0.35	-0.54	0.67	0.45	0.57
2500	0.08	-0.19	-0.74	-0.52	-0.80	0.40	0.18	0.26
3000	0.04	-0.27	-0.91	-0.61	-0.99	0.23	0.00	0.09
3500	0.04	-0.17	-0.85	-0.50	-0.93	0.26	0.00	0.06
4000	0.09	0.06	-0.57	-0.24	-0.69	0.45	0.23	0.30
4500	0.14	0.20	-0.34	-0.10	-0.50	0.54	0.32	0.36
5000	0.18	0.26	-0.21	-0.07	-0.42	0.51	0.33	0.26
5500	0.19	0.25	-0.17	-0.08	-0.43	0.41	0.20	0.04
6000	0.18	0.20	-0.26	-0.14	-0.54	0.23	-0.02	-0.29
6500	0.15	0.08	-0.45	-0.28	-0.77	-0.05	-0.38	-0.83
7000	0.11	-0.05	-0.68	-0.45	-1.08	-0.38	-0.79	-1.33
7500	0.08	-0.16	-0.85	-0.62	-1.35	-0.72	-1.17	-1.79
8000	0.10	-0.06	-0.75	-0.55	-1.37	-0.74	-1.33	-2.02
8500	0.15	0.11	-0.52	-0.38	-1.22	-0.59	-1.24	-1.86
9000	0.18	0.21	-0.40	-0.25	-1.12	-0.44	-1.12	-1.55
9500	0.15	0.22	-0.44	-0.22	-1.13	-0.35	-1.06	-1.19
10000	0.11	0.39	-0.34	0.01	-0.92	-0.10	-0.71	-0.59
10500	0.11	0.64	-0.09	0.36	-0.55	0.30	-0.25	0.01
11000	0.13	0.70	0.03	0.49	-0.32	0.42	0.11	0.44
11500	0.16	0.58	0.01	0.36	-0.29	0.34	0.22	0.58
12000	0.20	0.50	0.10	0.31	-0.14	0.38	0.46	0.78
12500	0.25	0.54	0.30	0.40	0.14	0.62	0.87	1.18
13000	0.31	0.67	0.53	0.60	0.53	1.01	1.27	1.58

Notes

- A. Performance and quality attributes and conditions not expressly stated in this specification document are intended to be excluded and do not form a part of this specification document.
- B. Electrical specifications and performance data contained in this specification document are based on Mini-Circuits' applicable established test performance criteria and measurement instructions.
- C. The parts covered by this specification document are subject to Mini-Circuits' standard limited warranty and terms and conditions (collectively, "Standard Terms"). Purchasers of this part are entitled to the rights and benefits contained therein. For a full statement of the Standard Terms and the exclusive rights and remedies thereunder, please visit Mini-Circuits' website at www.minicircuits.com/MCLStore/terms.jsp



Programmable Attenuator RUDAT-13G-60

Typical Performance Data @ +50°C

FREQUENCY (MHz)	Input VSWR (:1)							
	0.5 dB	10 dB	15 dB	20 dB	30 dB	40 dB	50 dB	60 dB
15	2.12	1.62	1.51	1.42	1.39	1.10	1.09	1.09
20	2.10	1.62	1.50	1.41	1.39	1.10	1.09	1.09
50	2.00	1.58	1.47	1.40	1.37	1.10	1.09	1.09
100	1.96	1.56	1.46	1.39	1.37	1.10	1.09	1.09
200	1.92	1.55	1.45	1.38	1.36	1.09	1.09	1.09
500	1.81	1.52	1.44	1.38	1.36	1.10	1.10	1.10
750	1.68	1.49	1.42	1.37	1.36	1.10	1.10	1.10
1000	1.54	1.45	1.41	1.36	1.36	1.10	1.10	1.10
1500	1.31	1.38	1.37	1.34	1.35	1.10	1.09	1.09
2000	1.32	1.38	1.37	1.33	1.34	1.09	1.09	1.09
2500	1.52	1.42	1.39	1.34	1.35	1.10	1.09	1.09
3000	1.72	1.49	1.44	1.37	1.36	1.11	1.11	1.11
3500	1.77	1.54	1.47	1.41	1.39	1.14	1.14	1.14
4000	1.64	1.54	1.49	1.43	1.42	1.18	1.17	1.17
4500	1.45	1.50	1.49	1.44	1.45	1.21	1.21	1.21
5000	1.31	1.45	1.47	1.43	1.46	1.23	1.23	1.23
5500	1.33	1.44	1.47	1.42	1.44	1.24	1.24	1.24
6000	1.47	1.47	1.48	1.41	1.42	1.25	1.25	1.25
6500	1.58	1.49	1.47	1.38	1.37	1.26	1.26	1.26
7000	1.58	1.46	1.43	1.33	1.32	1.28	1.28	1.28
7500	1.39	1.32	1.31	1.24	1.23	1.28	1.28	1.28
8000	1.15	1.15	1.18	1.14	1.14	1.29	1.30	1.30
8500	1.11	1.02	1.03	1.07	1.07	1.30	1.30	1.30
9000	1.19	1.14	1.10	1.15	1.14	1.31	1.31	1.31
9500	1.34	1.28	1.25	1.27	1.26	1.32	1.33	1.33
10000	1.65	1.45	1.42	1.39	1.38	1.32	1.32	1.32
10500	1.82	1.60	1.55	1.48	1.46	1.30	1.30	1.30
11000	1.70	1.64	1.61	1.52	1.51	1.27	1.27	1.27
11500	1.43	1.55	1.56	1.48	1.48	1.24	1.23	1.23
12000	1.25	1.43	1.50	1.42	1.45	1.26	1.26	1.26
12500	1.24	1.35	1.42	1.35	1.38	1.31	1.31	1.31
13000	1.43	1.36	1.37	1.32	1.32	1.39	1.39	1.39

Notes

- A. Performance and quality attributes and conditions not expressly stated in this specification document are intended to be excluded and do not form a part of this specification document.
- B. Electrical specifications and performance data contained in this specification document are based on Mini-Circuits' applicable established test performance criteria and measurement instructions.
- C. The parts covered by this specification document are subject to Mini-Circuits' standard limited warranty and terms and conditions (collectively, "Standard Terms"); Purchasers of this part are entitled to the rights and benefits contained therein. For a full statement of the Standard Terms and the exclusive rights and remedies thereunder, please visit Mini-Circuits' website at www.minicircuits.com/MCLStore/terms.jsp



Programmable Attenuator RUDAT-13G-60

Typical Performance Data @ +50°C

FREQUENCY (MHz)	Output VSWR (:1)							
	0.5 dB	10 dB	15 dB	20 dB	30 dB	40 dB	50 dB	60 dB
15	2.05	1.19	1.36	1.17	1.48	1.40	1.22	1.18
20	2.02	1.19	1.35	1.16	1.47	1.40	1.21	1.18
50	1.96	1.17	1.34	1.16	1.45	1.39	1.20	1.18
100	1.93	1.16	1.33	1.15	1.44	1.38	1.19	1.17
200	1.90	1.15	1.32	1.14	1.43	1.37	1.19	1.17
500	1.80	1.16	1.33	1.15	1.44	1.38	1.19	1.18
750	1.68	1.14	1.33	1.14	1.44	1.38	1.19	1.17
1000	1.53	1.13	1.32	1.14	1.43	1.37	1.18	1.17
1500	1.33	1.10	1.31	1.12	1.41	1.35	1.17	1.16
2000	1.35	1.11	1.30	1.12	1.39	1.34	1.17	1.16
2500	1.53	1.12	1.30	1.12	1.39	1.34	1.17	1.15
3000	1.75	1.17	1.32	1.16	1.41	1.37	1.20	1.19
3500	1.74	1.15	1.29	1.14	1.38	1.35	1.18	1.18
4000	1.66	1.19	1.35	1.19	1.44	1.41	1.23	1.24
4500	1.44	1.15	1.32	1.18	1.41	1.40	1.22	1.24
5000	1.32	1.16	1.35	1.20	1.43	1.43	1.24	1.28
5500	1.24	1.16	1.32	1.20	1.40	1.41	1.22	1.28
6000	1.37	1.21	1.33	1.23	1.41	1.44	1.24	1.32
6500	1.44	1.23	1.24	1.23	1.30	1.36	1.17	1.30
7000	1.53	1.22	1.23	1.21	1.29	1.35	1.16	1.28
7500	1.38	1.25	1.20	1.27	1.22	1.30	1.17	1.32
8000	1.20	1.12	1.06	1.16	1.08	1.15	1.08	1.18
8500	1.01	1.22	1.10	1.25	1.08	1.15	1.17	1.25
9000	1.16	1.26	1.21	1.27	1.17	1.09	1.28	1.18
9500	1.26	1.26	1.26	1.25	1.21	1.13	1.30	1.16
10000	1.72	1.46	1.51	1.40	1.44	1.36	1.50	1.29
10500	1.87	1.41	1.48	1.31	1.44	1.40	1.41	1.26
11000	1.93	1.49	1.57	1.39	1.55	1.54	1.49	1.37
11500	1.55	1.31	1.44	1.31	1.51	1.58	1.37	1.44
12000	1.27	1.15	1.27	1.19	1.36	1.44	1.22	1.35
12500	1.18	1.28	1.32	1.37	1.45	1.57	1.31	1.54
13000	1.30	1.32	1.18	1.33	1.21	1.27	1.22	1.36

Notes

- A. Performance and quality attributes and conditions not expressly stated in this specification document are intended to be excluded and do not form a part of this specification document.
- B. Electrical specifications and performance data contained in this specification document are based on Mini-Circuits' applicable established test performance criteria and measurement instructions.
- C. The parts covered by this specification document are subject to Mini-Circuits' standard limited warranty and terms and conditions (collectively, "Standard Terms"). Purchasers of this part are entitled to the rights and benefits contained therein. For a full statement of the Standard Terms and the exclusive rights and remedies thereunder, please visit Mini-Circuits' website at www.minicircuits.com/MCStore/terms.jsp



Programmable Attenuator RUDAT-13G-60

Typical Performance Data @ +50°C

FREQUENCY (MHz)	IP3 (dBm)	Insertion Loss @P _{IN} =0 dBm (dB)	Insertion Loss @P _{IN} =+23 dBm (dB)
10	23.09	4.66	5.62
50	36.23	4.11	4.19
100	40.78	4.97	4.99
200	41.20	5.03	5.04
500	41.01	4.90	4.94
1000	41.00	4.92	4.94
2000	41.04	5.97	5.99
3000	41.24	5.95	6.01
4000	40.52	6.94	6.95
5000	40.89	7.75	7.75
6000	42.00	7.81	7.79
7000	41.63	7.71	7.68
8000	41.11	7.91	7.89
9000	41.49	8.85	8.88
10000	42.27	9.11	9.27
11000	41.26	10.00	10.14
12000	41.44	10.41	10.58
13000	42.10	10.98	11.16

Notes

- A. Performance and quality attributes and conditions not expressly stated in this specification document are intended to be excluded and do not form a part of this specification document.
B. Electrical specifications and performance data contained in this specification document are based on Mini-Circuits' applicable established test performance criteria and measurement instructions.
C. The parts covered by this specification document are subject to Mini-Circuits' standard limited warranty and terms and conditions (collectively, "Standard Terms"); Purchasers of this part are entitled to the rights and benefits contained therein. For a full statement of the Standard Terms and the exclusive rights and remedies thereunder, please visit Mini-Circuits' website at www.minicircuits.com/MCLStore/terms.jsp



Programmable Attenuator

RUDAT-13G-60

Typical Performance Curves @ 0°C

Attenuation Accuracy vs. Frequency over Attenuation settings

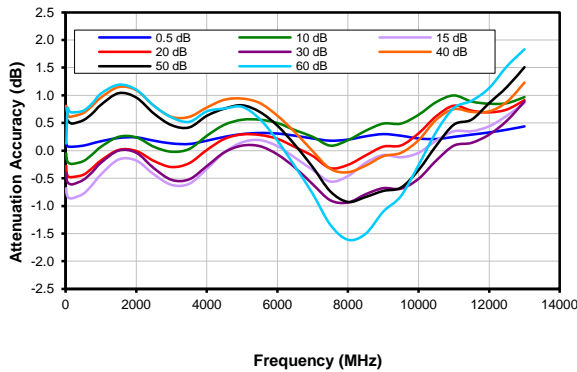

Attenuation relative to I.L. vs. Frequency over Attenuation settings

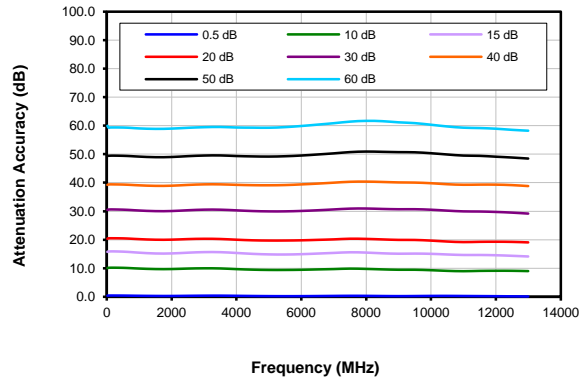

Input VSWR vs. Frequency over Attenuation settings

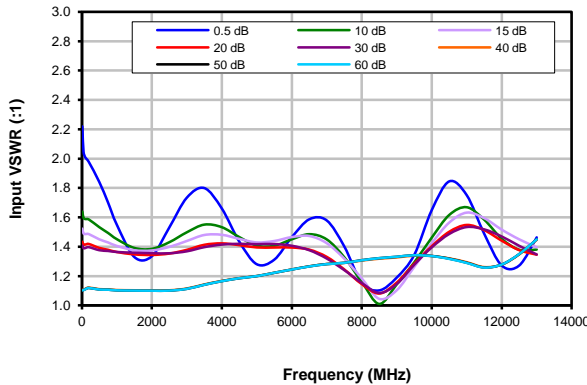

Output VSWR vs. Frequency over Attenuation settings

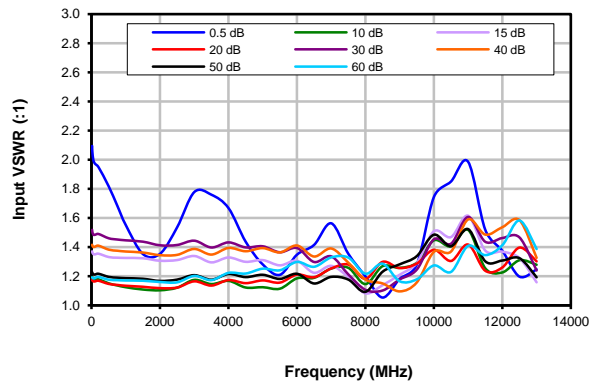

IP3 @ 0dB Attenuation

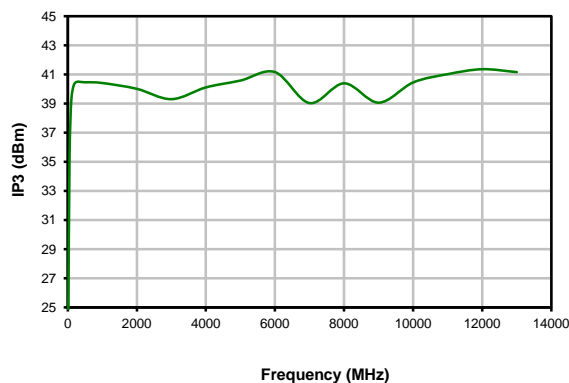

Insertion Loss

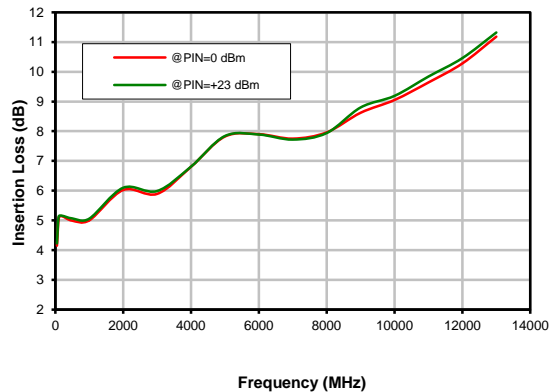

Notes

- A. Performance and quality attributes and conditions not expressly stated in this specification document are intended to be excluded and do not form a part of this specification document.
- B. Electrical specifications and performance data contained in this specification document are based on Mini-Circuits' applicable established test performance criteria and measurement instructions.
- C. The parts covered by this specification document are subject to Mini-Circuits' standard limited warranty and terms and conditions (collectively, "Standard Terms"); Purchasers of this part are entitled to the rights and benefits contained therein. For a full statement of the Standard Terms and the exclusive rights and remedies thereunder, please visit Mini-Circuits' website at www.minicircuits.com/MCLStore/terms.jsp

Programmable Attenuator

RUDAT-13G-60

Typical Performance Curves @ 25°C

Attenuation Accuracy vs. Frequency over Attenuation settings

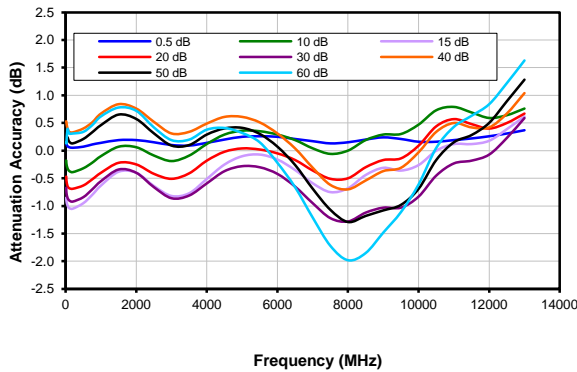

Attenuation relative to I.L. vs. Frequency over Attenuation settings

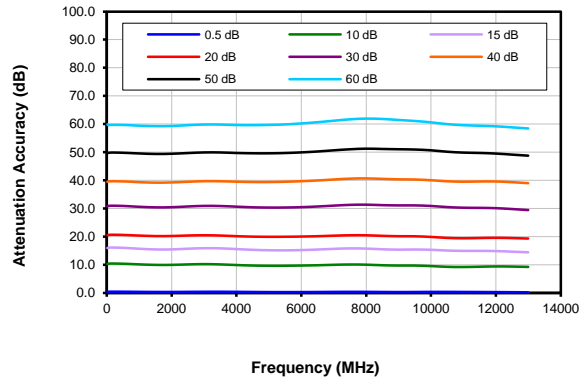

Input VSWR vs. Frequency over Attenuation settings

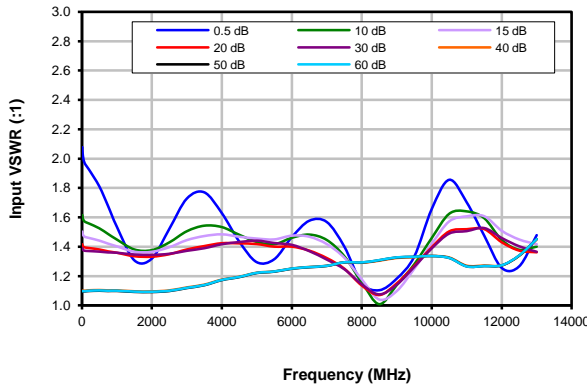

Output VSWR vs. Frequency over Attenuation settings

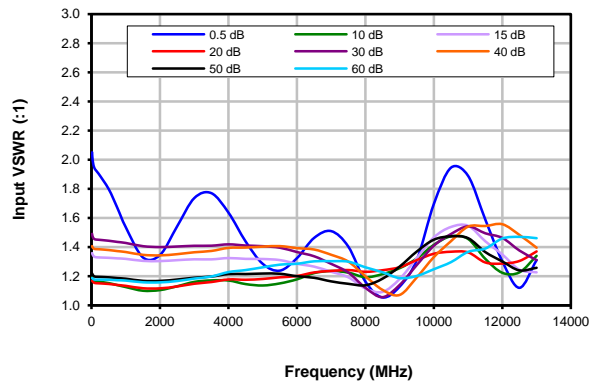

IP3 @ 0dB Attenuation

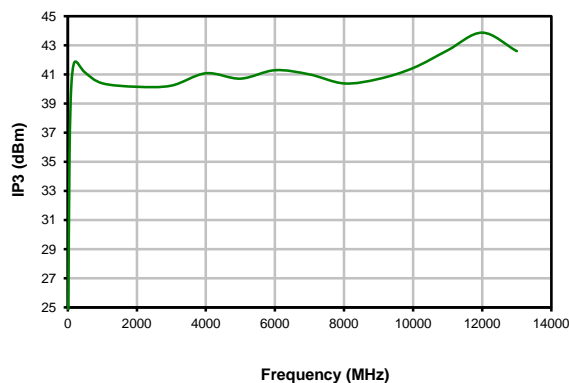

Insertion Loss

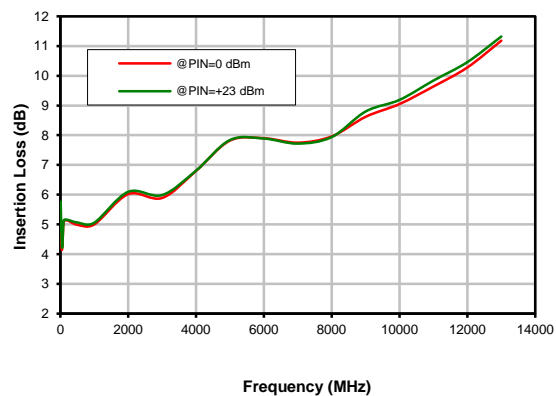

Notes

- A. Performance and quality attributes and conditions not expressly stated in this specification document are intended to be excluded and do not form a part of this specification document.
- B. Electrical specifications and performance data contained in this specification document are based on Mini-Circuits' applicable established test performance criteria and measurement instructions.
- C. The parts covered by this specification document are subject to Mini-Circuits' standard limited warranty and terms and conditions (collectively, "Standard Terms"); Purchasers of this part are entitled to the rights and benefits contained therein. For a full statement of the Standard Terms and the exclusive rights and remedies thereunder, please visit Mini-Circuits' website at www.minicircuits.com/MCLStore/terms.jsp

Programmable Attenuator

RUDAT-13G-60

Typical Performance Curves @ 50°C

Attenuation Accuracy vs. Frequency over Attenuation settings

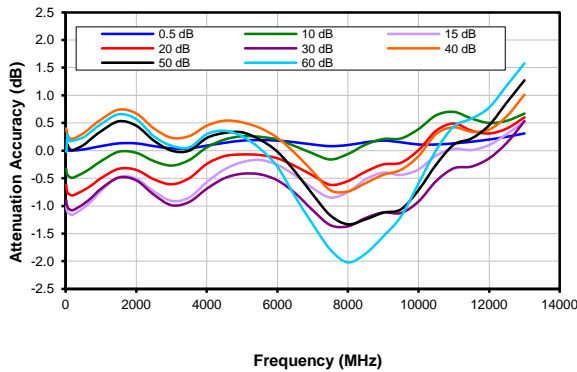

Attenuation relative to I.L. vs. Frequency over Attenuation settings

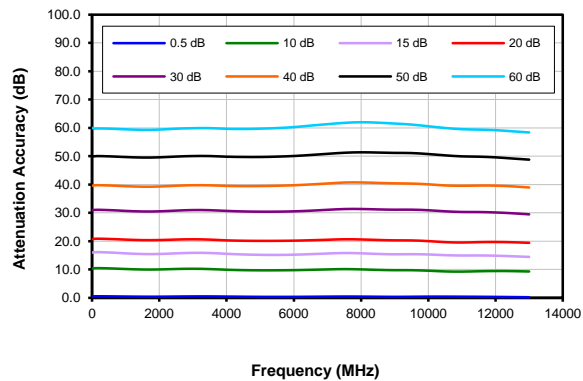

Input VSWR vs. Frequency over Attenuation settings

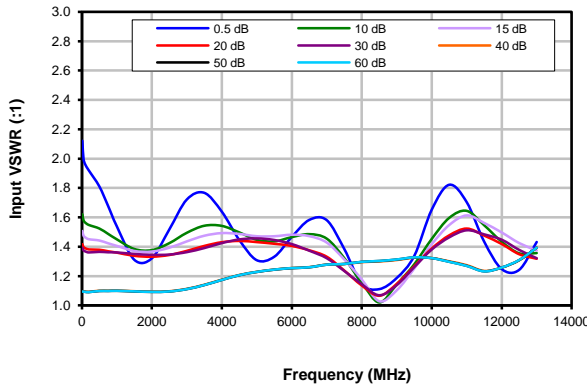

Output VSWR vs. Frequency over Attenuation settings

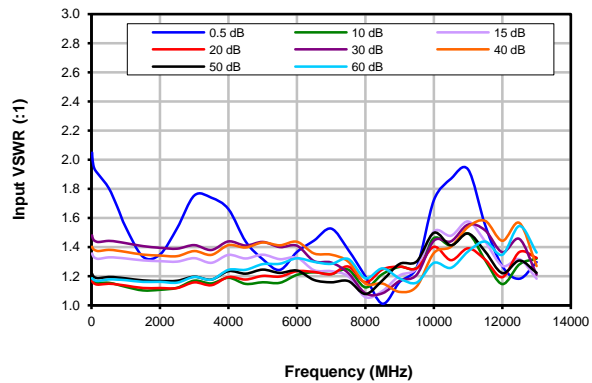

IP3 @ 0dB Attenuation

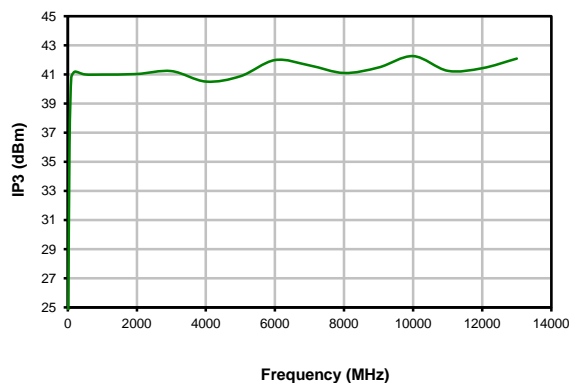

Insertion Loss

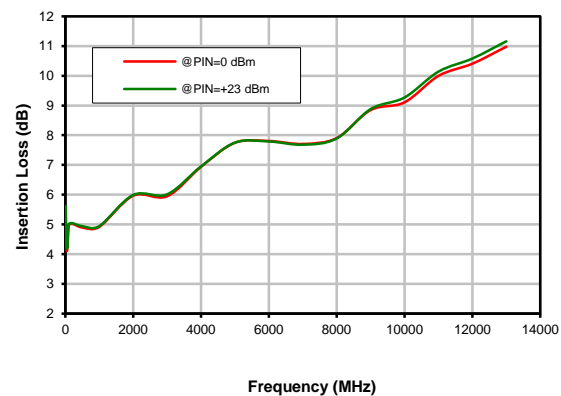

Notes

- A. Performance and quality attributes and conditions not expressly stated in this specification document are intended to be excluded and do not form a part of this specification document.
- B. Electrical specifications and performance data contained in this specification document are based on Mini-Circuits' applicable established test performance criteria and measurement instructions.
- C. The parts covered by this specification document are subject to Mini-Circuits' standard limited warranty and terms and conditions (collectively, "Standard Terms"); Purchasers of this part are entitled to the rights and benefits contained therein. For a full statement of the Standard Terms and the exclusive rights and remedies thereunder, please visit Mini-Circuits' website at www.minicircuits.com/MCLStore/terms.jsp

Case Style

QF

Outline Dimensions

QF3370

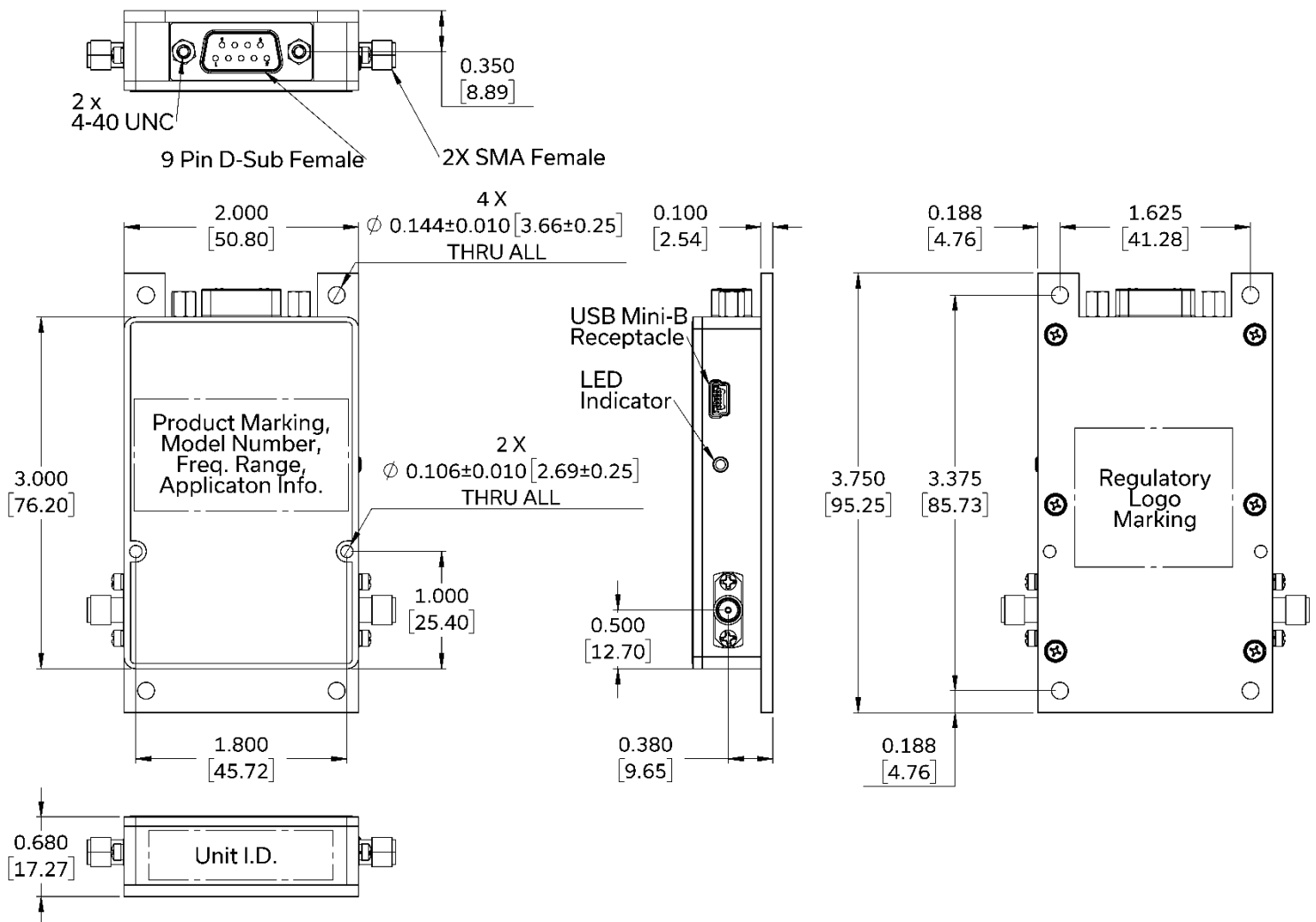

NOTES:

1. Case material: Aluminum alloy.
2. Case Finish: Nickel Plate.
3. Dimensions: 2 Pl. ± 0.03 inch; 3 Pl. ± 0.015 inch.
4. Weight: 150 grams.
5. Marking may contain other features or characters for internal lot control.



www.minicircuits.com P.O. Box 350166, Brooklyn, NY 11235-0003 (718) 934-4500 sales@minicircuits.com



Environmental Specifications **ENV55T1**

All Mini-Circuits products are manufactured under exacting quality assurance and control standards, and are capable of meeting published specifications after being subjected to any or all of the following physical and environmental test.

Specification	Test/Inspection Condition	Reference/Spec
Operating Temperature	-0° to 50° C Ambient Environment	Individual Model Data Sheet
Storage Temperature	-20° to 85° C Ambient Environment	Individual Model Data Sheet
Operating and Storage Humidity	5% to 85% RH (non-condensing)	Ambient
Bench Handling Test	Bench Top Tip 45° & Drop	MIL-PRF-28800F
Transit Drop Test	Free Fall Drop, 20 cm (7.9 inches)	MIL-PRF-28800F Class 3