



COAXIAL

# Termination

ROSE-50+

Mini-Circuits

50Ω DC to 6000 MHz SMB-Female

## FEATURES

- SMB Connector with female center contact
- Wideband, DC to 6000 MHz
- Rugged Construction



Generic photo used for illustration purposes only

Model No.	ROSE-50+
Case Style	LL604
Connectors	SMB-Female

### +RoHS Compliant

The +Suffix identifies RoHS Compliance. See our website for methodologies and qualifications

## APPLICATIONS

- Cellular Communications
- Test Setup
- Instrumentation
- PCS

## ELECTRICAL SPECIFICATIONS

Parameter	Frequency (MHz)	Min.	Typ.	Max.	Units
Frequency Range		DC		6000	MHz
Impedance			50		Ohms
Return Loss	DC - 2000	30	—	—	dB
	DC - 4000	23	—	—	
	DC - 6000	20	—	—	
Power Rating <sup>1</sup>	DC - 6000	—	—	0.50	W

1. At 70°C, derate linearly at 0.005W/°C to .35W at 100°C.

## ABSOLUTE MAXIMUM RATINGS<sup>1</sup>

Parameter	Ratings
Operating Temperature	-55°C to +100°C
Storage Temperature	-55°C to +100°C

1. Permanent damage may occur if any of these limits are exceeded.





COAXIAL

# Termination

ROSE-50+

Mini-Circuits

50Ω DC to 6000 MHz SMB-Female

## OUTLINE DRAWING

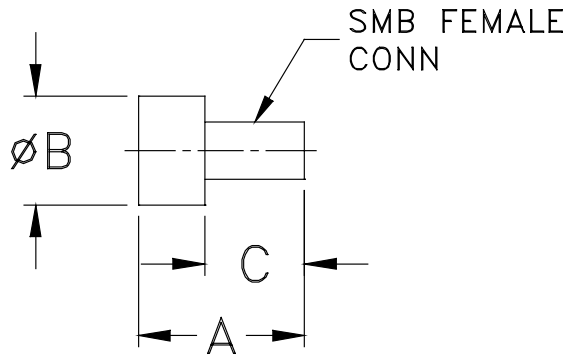

## OUTLINE DIMENSIONS (Inch mm)

A	B	D	wt
0.55	0.36	0.33	grams
13.97	9.14	8.38	4.0



COAXIAL

# Termination

ROSE-50+

Mini-Circuits

50Ω DC to 6000 MHz SMB-Female

## TYPICAL PERFORMANCE DATA

Frequency (MHz)	Return Loss (dB)
10	37.6
100	37.4
200	37.4
500	37.4
1000	38.3
2000	39.7
3000	35.3
4000	33.2
5000	31.8
6000	26.8

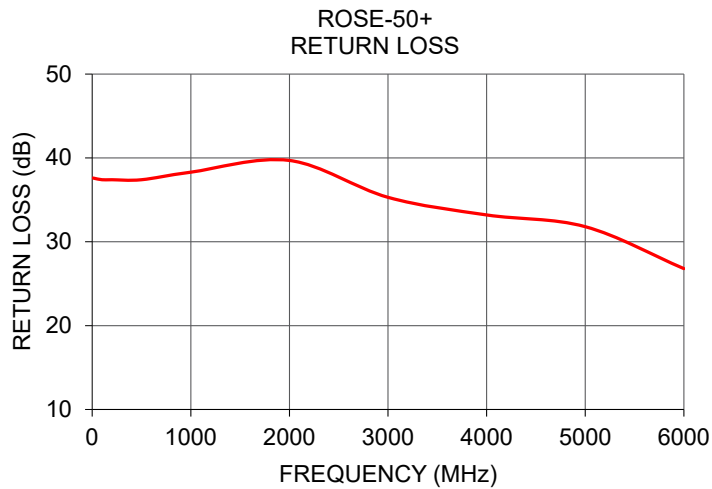

## Typical Performance Data

FREQUENCY (MHz)	RETURN LOSS (dB)
1	69.84
100	70.87
200	65.00
500	50.04
1000	49.61
2000	45.48
3000	47.04
4000	35.88
5000	28.01
6000	24.18

## Typical Performance Curves



## Outline Dimensions

LL604

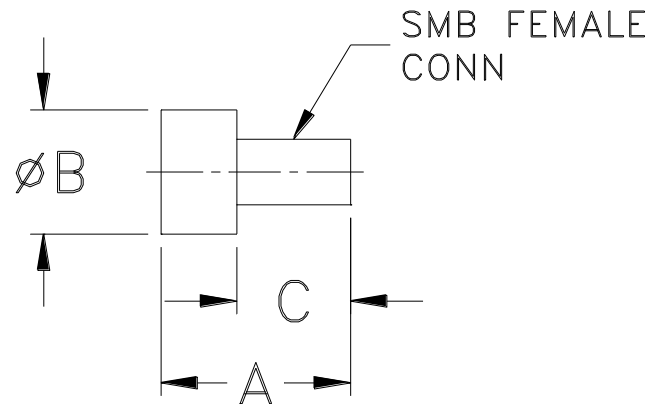

CASE #.	A	B	C	WT GRAMS
LL604	.55 (13.97)	.36 (9.14)	.33 (8.38)	4.0

Dimensions are in inches (mm). Tolerances: 2Pl.  $\pm .03$ ; 3Pl.  $\pm .015$

### Notes:

1. Case Material: Brass.
2. Case Finish: Gold plate.



P.O. Box 350166, Brooklyn, New York 11235-0003 (718) 934-4500 Fax (718) 332-4661 For detailed performance specs & shopping online see Mini-Circuits web site



The Design Engineers Search Engine Provides ACTUAL Data Instantly From MINI-CIRCUITS At: [www.minicircuits.com](http://www.minicircuits.com)

RF/IF MICROWAVE COMPONENTS



All Mini-Circuits products are manufactured under exacting quality assurance and control standards, and are capable of meeting published specifications after being subjected to any or all of the following physical and environmental test.

<b>Specification</b>	<b>Test/Inspection Condition</b>	<b>Reference/Spec</b>
Operating Temperature	-55° to 100°C Ambient Environment	Individual Model Data Sheet
Storage Temperature	-55° to 100° C Ambient Environment	Individual Model Data Sheet
Barometric Pressure	100,000 Feet	MIL-STD-202, Method 105, Condition D
Humidity	90% RH, 65°C Units may require bake-out after humidity to restore full performance.	MIL-STD-202, Method 103
Thermal Shock	-65° to 125°C, 5 cycles	MIL-STD-202, Method 107, Condition B
Vibration (High Frequency)	20g peak, 10-2000 Hz, 12 times in each of three perpendicular directions (total 36)	MIL-STD-202, Method 204, Condition D
Mechanical Shock	100g, 6ms sawtooth, 3 shocks each direction 3 axes (total 18)	MIL-STD-202, Method 213, Condition I