



THE BIG DEAL

- Low mainline loss, 1.7 dB typ. at 1.8 GHz
- Good Return Loss, 18 dB
- Excellent coupling flatness, ±0.2 dB
- Supports DOCSIS® 3.1 Systems

APPLICATIONS

- DOCSIS 3.1
- Cable TV



Generic photo used for illustration purposes only

CASE STYLE: TT2315

+RoHS Compliant
 The +Suffix identifies RoHS Compliance.
 See our website for methodologies and qualifications

PRODUCT OVERVIEW

Mini-Circuits RDC-10-182-75X+ surface-mount directional coupler provides 10 dB coupling with excellent flatness, low mainline loss, high directivity, and good return loss for 75Ω applications from 5 to 1800 MHz, supporting a variety of broadband applications including DOCSIS 3.1 systems and equipment. This model features core and wire construction with wrap-around terminations for good solderability and easy visual inspection.

KEY FEATURES

Feature	Advantages
Broadband, 5 to 1800 MHz	Supports bandwidth requirements for DOCSIS 3.1 systems and equipment.
Low mainline loss, 1.7 dB	Provides excellent through-path signal transmission and maintains low heat dissipation, avoiding the need for special heat sinking methods.
Power handling, up to 1W	Usable in systems with a variety of signal power requirements.
Excellent return loss, 18 dB typ.	Provides excellent matching for 75Ω systems.
Top Hat feature	Improves speed and accuracy of pick and place assembly.



ELECTRICAL SPECIFICATIONS AT 25°C

Parameter	Condition (MHz)	Min.	Typ.	Max.	Unit
Frequency Range		5		1800	MHz
Mainline Loss ¹	5 - 1250	—	1.3	1.8	dB
	1250 - 1800	—	1.9	2.8	
Nominal Coupling	5 - 1800	—	10±0.5	—	dB
Coupling Flatness(±)	5 - 1800	—	0.1	0.5	dB
Directivity	5 - 870	15	20	—	dB
	870 - 1250	14	20	—	
	1250 - 1800	10	15	—	
Return Loss (Input)	5 - 1800	—	18	—	dB
Return Loss (Output)	5 - 1800	—	20	—	dB
Return Loss (Coupled)	5 - 1800	—	18	—	dB
Input Power	5 - 1800	—	—	1.0	W

1. Mainline loss includes theoretical power loss at coupled port.

MAXIMUM RATINGS

Parameter	Ratings
Operating Temperature	-40°C to 85°C
Storage Temperature	-55°C to 100°C

Permanent damage may occur if any of these limits are exceeded.

ELECTRICAL SCHEMATIC

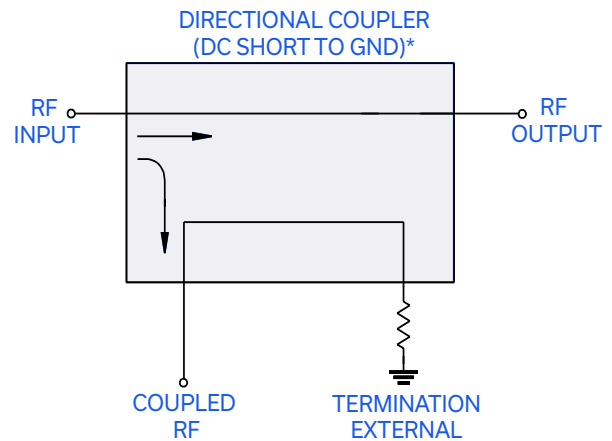

*Electrical schematic is for Directional coupler with internal transformer(s) and external termination



Directional Coupler

RDC-10-182-75X+

75Ω 10dB 5 to 1800 MHz

PIN CONNECTIONS

Function	Pad Number
INPUT	1
OUTPUT	6
COUPLED	3
GROUND	2
75Ω TERM EXTERNAL	4
ISOLATE (DO NOT USE)	5

PRODUCT MARKING: US

DEMO BOARD MCL P/N: TB-917+
SUGGESTED PCB LAYOUT (PL-452)

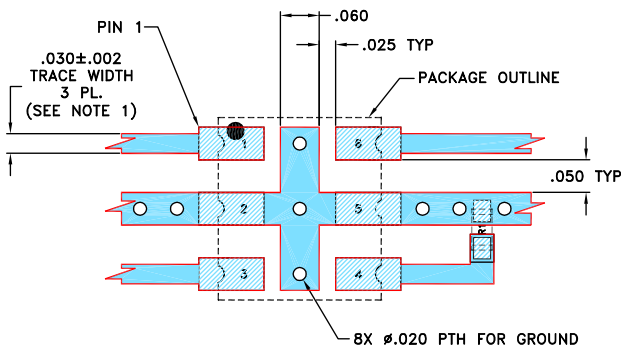

NOTES:

- TRACE WIDTH IS SHOWN FOR ROGERS R04350B WITH DIELECTRIC THICKNESS .030" ± .002"; COPPER: 1/2 OZ. EACH SIDE. FOR OTHER MATERIALS TRACE WIDTH MAY NEED TO BE MODIFIED.
- .0603 SIZE CHIP RESISTOR FOOT PRINT SHOWN FOR REFERENCE. FOR RESISTOR VALUE REFER TO TB-917+.
- BOTTOM SIDE OF THE PCB IS CONTINUOUS GROUND PLANE.

DENOTES PCB COPPER LAYOUT WITH SMOBC (SOLDER MASK OVER BARE COPPER)

DENOTES COPPER LAND PATTERN FREE OF SOLDER MASK

OUTLINE DRAWING

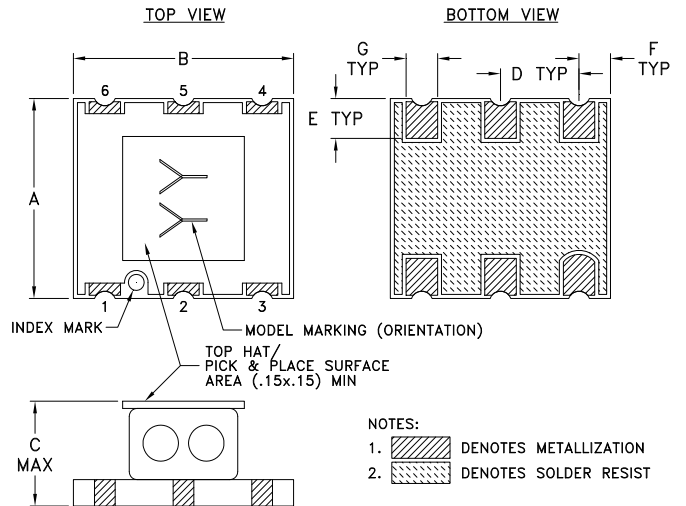

PCB Land Pattern

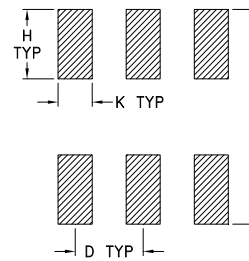

Suggested Layout,
Tolerance to be within ±.002

OUTLINE DIMENSIONS (Inches/mm)

A	B	C	D	E	F	G	H	J	K
.250	.280	.140	.100	.050	.040	.040	.100	.310	.050
6.35	7.11	3.56	2.54	1.27	1.02	1.02	2.54	7.87	1.27

Weight: 0.35 grams

TAPE & REEL INFORMATION: F34



75Ω 10dB 5 to 1800 MHz

TYPICAL PERFORMANCE DATA

Frequency (MHz)	Mainline Loss (dB) In-Out	Coupling (dB) In-Cpl	Directivity (dB)	Return Loss (dB)		
				In	Out	Cpl
5	1.05	9.94	21.99	19.68	29.18	19.42
20	1.02	9.92	21.90	20.50	50.34	20.13
50	1.06	9.95	21.59	20.39	43.13	19.99
100	1.10	9.98	21.36	20.49	37.38	19.91
200	1.13	10.02	20.98	20.65	30.84	20.17
400	1.15	10.02	19.99	21.04	25.05	20.63
800	1.26	9.96	18.38	20.78	21.42	21.79
900	1.30	9.95	17.97	20.62	21.41	21.85
1000	1.33	9.94	17.50	20.39	21.40	21.71
1218	1.43	9.92	16.18	20.34	21.08	20.35
1500	1.63	9.97	14.15	19.39	19.20	17.16
1600	1.76	10.03	13.43	18.15	18.36	15.81
1800	2.05	10.19	12.43	15.89	16.67	13.50

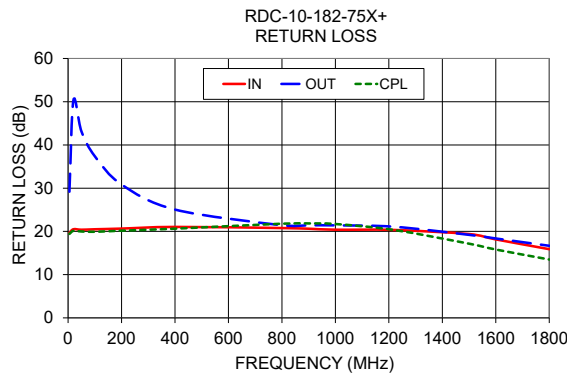
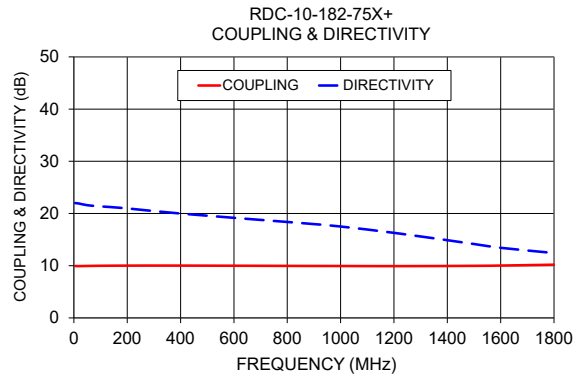
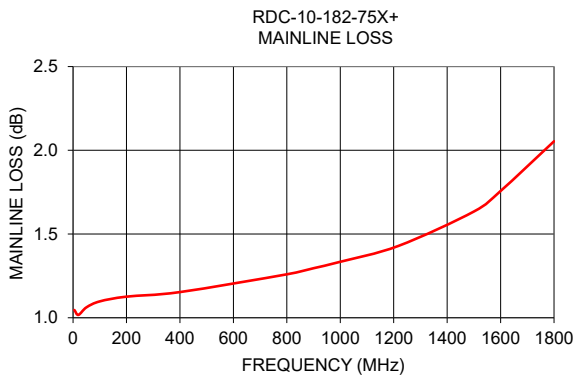

- NOTES**
- A. Performance and quality attributes and conditions not expressly stated in this specification document are intended to be excluded and do not form a part of this specification document.
 - B. Electrical specifications and performance data contained in this specification document are based on Mini-Circuit's applicable established test performance criteria and measurement instructions.
 - C. The parts covered by this specification document are subject to Mini-Circuits standard limited warranty and terms and conditions (collectively, "Standard Terms"); Purchasers of this part are entitled to the rights and benefits contained therein. For a full statement of the standard. Terms and the exclusive rights and remedies thereunder, please visit Mini-Circuits' website at www.minicircuits.com/MCLStore/terms.jsp

Outline Dimensions

TT2315

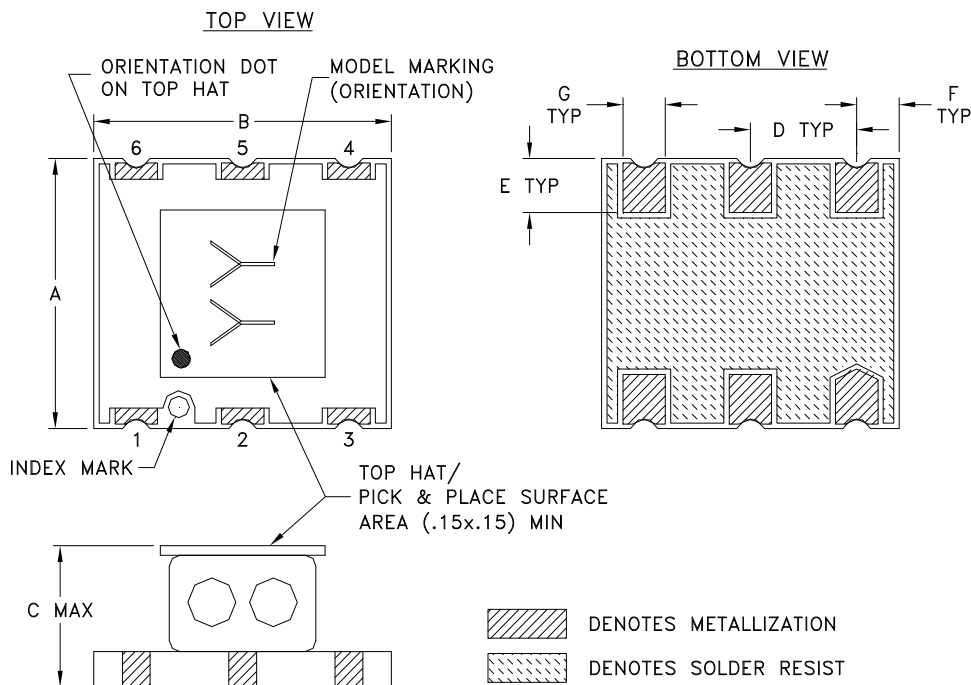

PCB Land Pattern

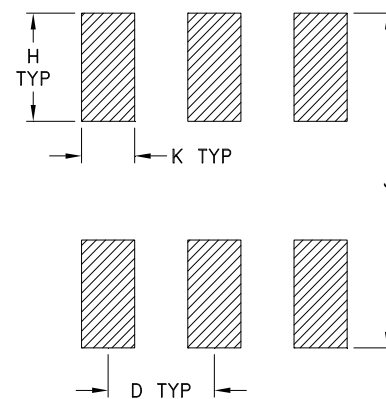

SUGGESTED LAYOUT
TOLERANCE TO BE WITHIN ± 0.02

CASE #	A	B	C	D	E	F	G	H	J	K	WT. GRAMS
TT2315	.250 (6.35)	.280 (7.11)	.140 (3.56)	.100 (2.54)	.050 (1.27)	.040 (1.02)	.040 (1.02)	.100 (2.54)	.310 (7.87)	.050 (1.27)	.35

Dimensions are in inches (mm). Tolerances: 2Pl. $\pm .01$; 3 Pl. $\pm .005$

Notes:

1. Open style, Base material: Printed wiring laminate.
2. Termination finish: 3-5 μ inch (.08-.13 microns) Gold over 120-240 μ inch (3.05-6.10 microns) Nickel plate. All models, (+) suffix.
3. Top-Hat total thickness: .013 inches MAX.
4. Orientation Dot on Top Hat & PCB corresponds to Pin #1.

THIRD ANGLE PROJECTION

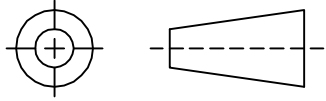

REVISIONS

REV	ECN No.	DESCRIPTION	DATE	DR	AUTH
OR	M158078	NEW RELEASE	09/16/16	CA	IL

**SUGGESTED MOUNTING CONFIGURATION
FOR TT2315 CASE STYLE, "06DC03" PIN CODE**

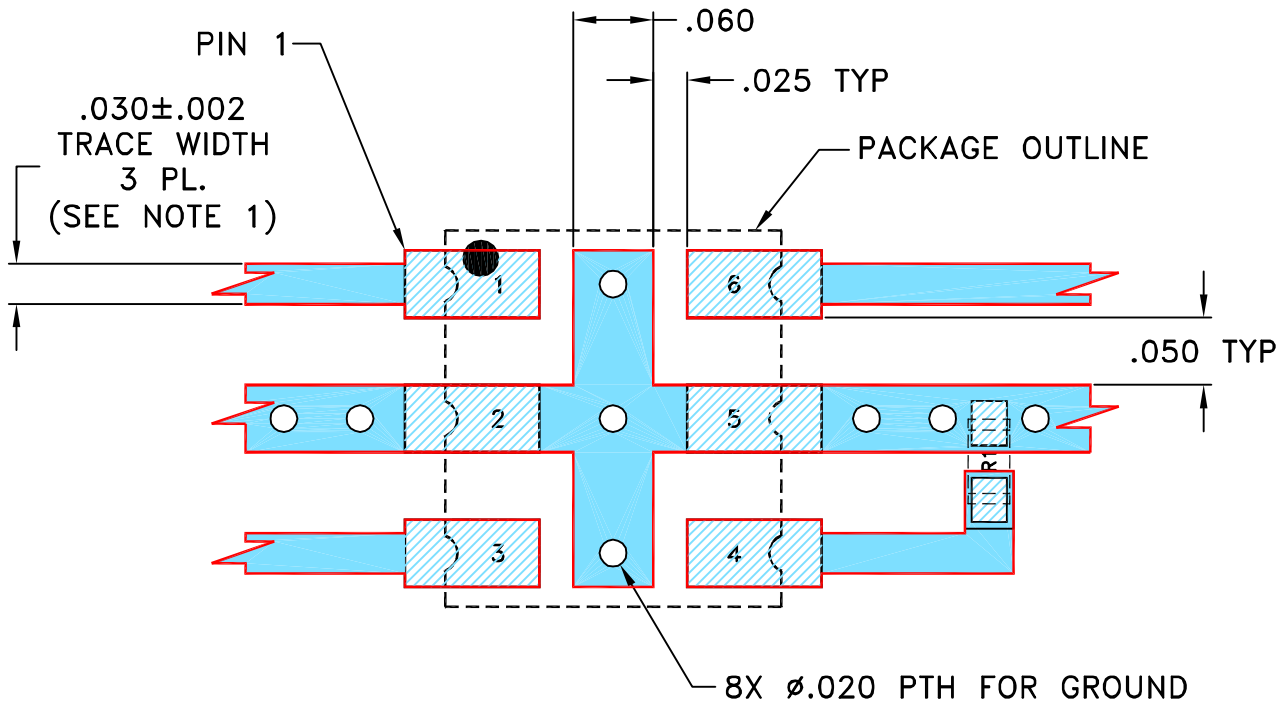

NOTES:

1. TRACE WIDTH IS SHOWN FOR ROGERS R04350B WITH DIELECTRIC THICKNESS .030" ± .002"; COPPER: 1/2 OZ. EACH SIDE.
FOR OTHER MATERIALS TRACE WIDTH MAY NEED TO BE MODIFIED.
2. 0603 SIZE CHIP RESISTOR FOOT PRINT SHOWN FOR REFERENCE,
FOR RESISTOR VALUE REFER TO TB-917+.
3. BOTTOM SIDE OF THE PCB IS CONTINUOUS GROUND PLANE.

DENOTES PCB COPPER LAYOUT WITH SMOBC (SOLDER MASK OVER BARE COPPER)

DENOTES COPPER LAND PATTERN FREE OF SOLDER MASK

UNLESS OTHERWISE SPECIFIED	INITIALS	DATE
DIMENSIONS ARE IN INCHES TOLERANCES ON: 2 PL DECIMALS ± 3 PL DECIMALS ± .005 ANGLES ± FRACTIONS ±	DRAWN	CA 09/15/16
	CHECKED	IL 09/16/16
	APPROVED	YL 09/16/16

Mini-Circuits® 13 Neptune Avenue
Brooklyn NY 11235

PL, 06DC03, TT2315, TB-917+

Mini-Circuits®
THIS DOCUMENT AND ITS CONTENTS ARE THE PROPERTY OF MINI-CIRCUITS. EXCEPT FOR USE EXPRESSLY GRANTED, IN WRITING, TO ITS VENDORS, VENDEE AND THE UNITED STATES GOVERNMENT, MINI-CIRCUITS RESERVES ALL PROPRIETARY DESIGN, USE, MANUFACTURING AND REPRODUCTION RIGHTS THERETO. THESE CONTENTS SHALL NOT BE USED, DUPLICATED OR DISCLOSED TO ANY OUTSIDE PARTY, IN WHOLE OR IN PART, WITHOUT WRITTEN PERMISSION OF MINI-CIRCUITS.

SIZE A	CODE IDENT 15542	DRAWING NO: 98-PL-452	REV: OR
FILE: 98PL452	SCALE: 7:1	SHEET: 1 OF 1	

Evaluation Board and Circuit

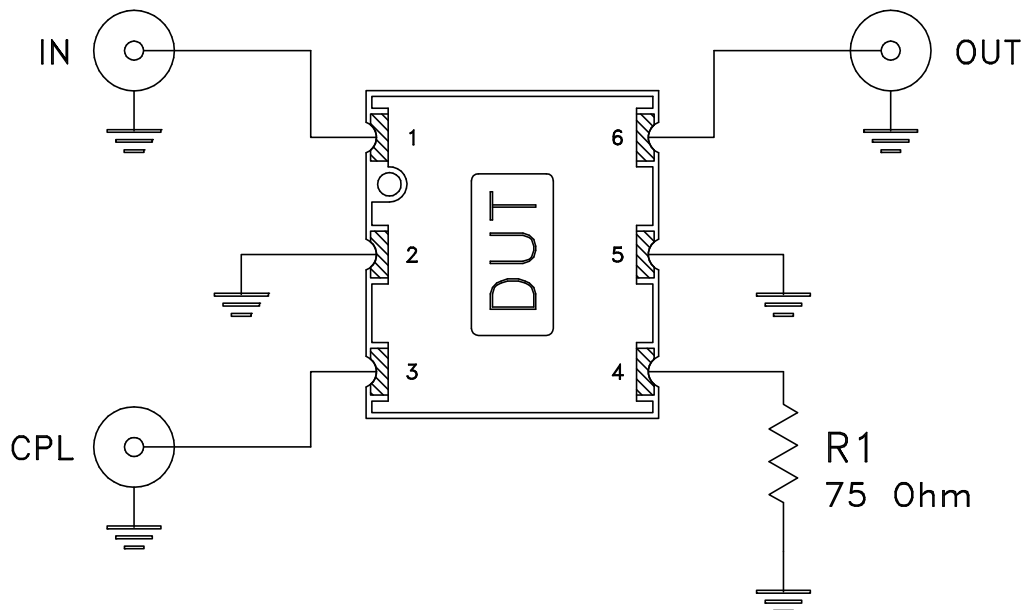
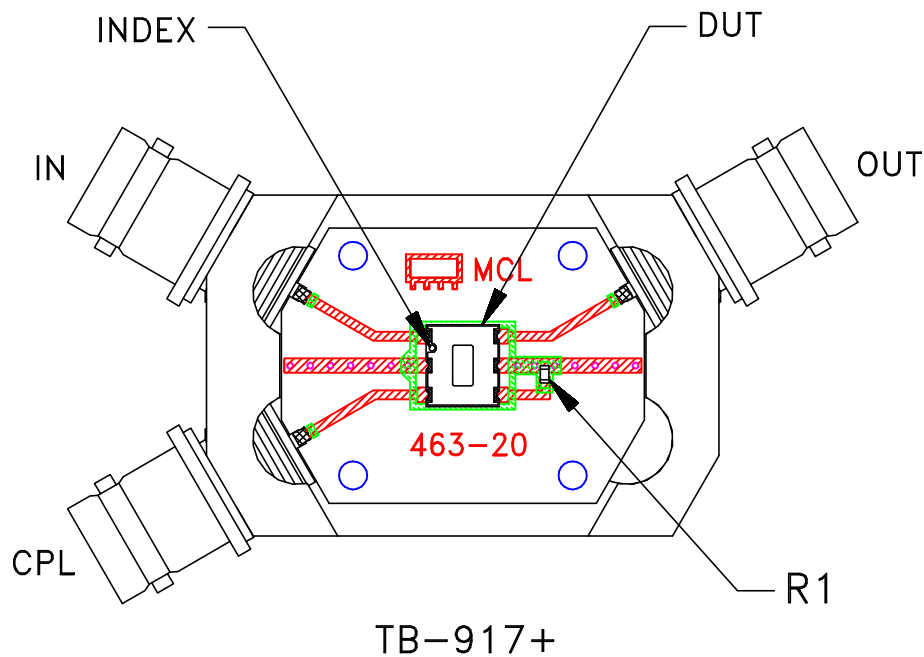

Schematic Diagram

Notes:

1. 75 Ohm BNC connectors.
2. PCB Material: R04350 or equivalent,
Dielectric Constant=3.5, Thickness=.030 inch.

 **Mini-Circuits®**



All Mini-Circuits products are manufactured under exacting quality assurance and control standards, and are capable of meeting published specifications after being subjected to any or all of the following physical and environmental test.

Specification	Test/Inspection Condition	Reference/Spec
Operating Temperature	-40° to 85°C Ambient Environment	Individual Model Data Sheet
Storage Temperature	-55° to 100° C Ambient Environment	Individual Model Data Sheet
Humidity	90 to 95% RH, 240 hours, 50°C	MIL-STD-202, Method 103, Condition A, Except 50°C and end-point electrical test done within 12 hours
Thermal Shock	-55° to 100°C, 100 cycles	MIL-STD-202, Method 107, Condition A-3, except +100°C
Solder Reflow Heat	Sn-Pb Eutetic Process: 225°C peak Pb-Free Process 245° - 250°C peak	J-STD-020, Table 4-1, 4-2 and 5-2, Figure 5-1
Solderability	10X Magnification	J-STD-002, 95% Coverage
Vibration (High Frequency)	20g peak, 10-2000 Hz, 12 times in each of three perpendicular directions (total 36)	MIL-STD-202, Method 204, Condition D
Mechanical Shock	50g, 11 ms, 1/2-sine, 18 shocks: 3 each direction, each of 3 axes	MIL-STD-202, Method 213, Condition A
Marking Resistance to Solvents	Isopropyl alcohol + mineral spirits at 25°C; terpene defluxer at 25°C; distilled water + proylene glycol monomethyl ether + monoethanolamine at 63°C to 70°C	MIL-STD-202, Method 215