



THE BIG DEAL

- Super wide bandwidth, solid-state design
- High isolation, absorptive switch
- USB & Ethernet control and automation
- Daisy-chain control of up to 25 modules

APPLICATIONS

- RF & millimeter wave signal routing / switch matrices
- Satellite communications up to V band
- Military radio, radar & electronic warfare
- Microwave radio / cellular infrastructure
- Test & measurement systems



Generic photo used for illustration purposes only

PRODUCT OVERVIEW

Mini-Circuits' RCS-1SP2T-A673 is a fast switching absorptive SPDT covering an ultra-wide bandwidth, from 0.1 to 67 GHz. The solid-state design features an impressive combination of high isolation, low insertion loss and good linearity across the entire band, with internal terminations on ports 1 to 2.

The switch is supplied in a low profile package (3.35" x 2.62" x 0.575") with the 3 precision 1.85 mm connectors mounted on the same face for ease of access when installed in integrated test systems. Control and power connections are kept clear on the opposite face, including USB type C for local power and control, RJ45 for Ethernet control and 2 serial data bus connections for daisy-chaining with additional switch modules.

Full software support is provided, including our user-friendly GUI application for Windows and a full API with programming instructions for Windows and Linux environments.

KEY FEATURES

Feature	Advantages
Fast switching sequences	Program automated switching sequences to run with extremely fast transitions and no external control.
High performance	Solid-state design combining high isolation with low insertion loss from 0.1 to 67 GHz.
Dynamic daisy-chain control	Control up to 25 switches through a single USB or LAN interface.
USB & Ethernet control	USB HID and Ethernet interfaces provides easy compatibility with a wide range of software setups and programming environments.
Full software support	User friendly Windows GUI (graphical user interface) allows manual control straight out of the box, while the comprehensive API (application programming interface) with examples and instructions allows easy automation in most programming environments.

Trademarks:

Windows is a registered trademark of Microsoft Corporation in the United States and other countries ; Linux is a registered trademark of Linus Torvalds ; Pentium is a registered trademark of Intel Corporation. Neither Mini-Circuits nor the Mini-Circuits products are affiliated with or endorsed by the owners of the referenced trademarks. Mini-Circuits and the Mini-Circuits logo are registered trademarks of Scientific Components Corporation.



ELECTRICAL SPECIFICATIONS AT 0 TO 50°C

Parameter	Ports	Condition (GHz)	Min.	Typ.	Max.	Unit
Frequency Range	-	-	0.1	-	67	GHz
Insertion Loss	COM to any active port	0.1 - 18	-	2.0	3.5	dB
		18 - 40	-	3.5	6.0	
		40 - 60	-	5.0	7.5	
		60 - 67	-	7.0	-	
Isolation	Between ports 1 to 2	0.1 - 18	40	60	-	dB
		18 - 40	35	48	-	
		40 - 60	35	45	-	
		60 - 67	-	40	-	
	COM to any terminated port (including disconnected state)	0.1 - 18	40	55	-	
		18 - 40	35	45	-	
		40 - 60	33	45	-	
		60 - 67	-	40	-	
Return Loss	COM port (in all active states)	0.1 - 18	-	17	-	dB
		18 - 40	-	15	-	
		40 - 60	-	9	-	
		60 - 67	-	7	-	
	Any port connected to COM	0.1 - 18	-	17	-	
		18 - 40	-	15	-	
		40 - 60	-	10	-	
		60 - 67	-	8	-	
	Any terminated port	0.1 - 18	-	20	-	
		18 - 40	-	13	-	
		40 - 60	-	10	-	
		60 - 67	-	8	-	
Power Input @1 dB Compression	COM to any active port	0.1 - 67	-	+28	-	dBm
IP3	COM to any active port	0.1 - 67	-	+50	-	dBm
Transition Time ¹	-	-	-	600	-	ns
Minimum Dwell Time ²	High-speed mode	-	-	20	-	μs
Switching Time (USB) ³	-	-	-	2	-	ms

1. Transition Time spec represents the time that the RF signal paths are interrupted during switching and thus is specified without communication delays.

2. Minimum Dwell Time is the shortest time that can be achieved between 2 switch transitions when programming an automated switch sequence.

3. Switching Time (USB) is the time from issuing a single software command via USB to the switch state changing. The most significant factor is the host PC, influenced by CPU load and USB protocol. The time shown is an estimate for a medium CPU load and USB 2.0 connection.



ELECTRICAL SPECIFICATIONS AT 0 TO 50°C (CONTINUED)

Parameter	Ports	Condition (GHz)	Min.	Typ.	Max.	Unit
Supply Voltage (Vcc)	USB port	-	4.75	5	5.25	V _{DC}
Supply Current (Icc) ⁴	Ethernet disabled	-	-	280	340	mA
	Ethernet enabled	-	-	340	400	
Current Pass-Through ⁵	-	-	-	-	500	mA
Operating RF Input Power	Through path (Hot & Cold switching)	0.1 - 0.3	-	-	+24	dBm
		0.3 - 40	-	-	+26	
		40 - 67	-	-	+24	
	Into termination	0.1 - 0.3	-	-	+22	
		0.3 - 40	-	-	+24	
		40 - 67	-	-	+22	

4. USB Current draw for a single unit with no slave units.

5. Current Pass-Through is the maximum supply current handling of a unit with slave modules attached. If controlling a large number of slave modules additional power supplies should be included to ensure this limit is not exceeded.

ABSOLUTE MAXIMUM RATINGS⁶

Operating Temperature	0°C to 50°C
Storage Temperature	-20°C to 60°C
DC Supply Voltage Max @ USB and Pin 4 of D-Sub	6V
DC Voltage @ RF Ports	0V

6. Permanent damage may occur if any of these limits are exceeded. Operating in the range between operating power limits and absolute maximum ratings for extended periods of time may result in reduced life and reliability.



TYPICAL PERFORMANCE GRAPHS

Insertion Loss over Temperature (1 Active)

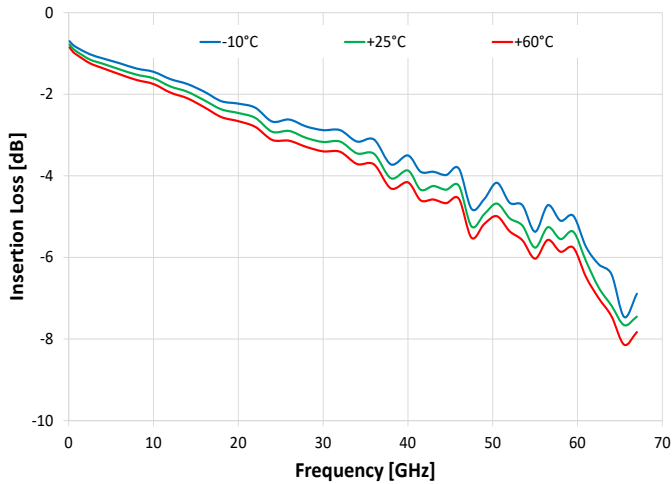

Insertion Loss 1 - 2 Active

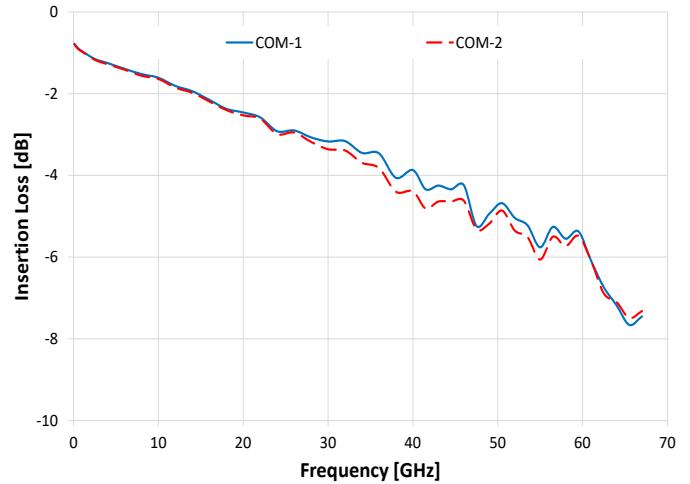

Isolation Com to 1 (2 Active)

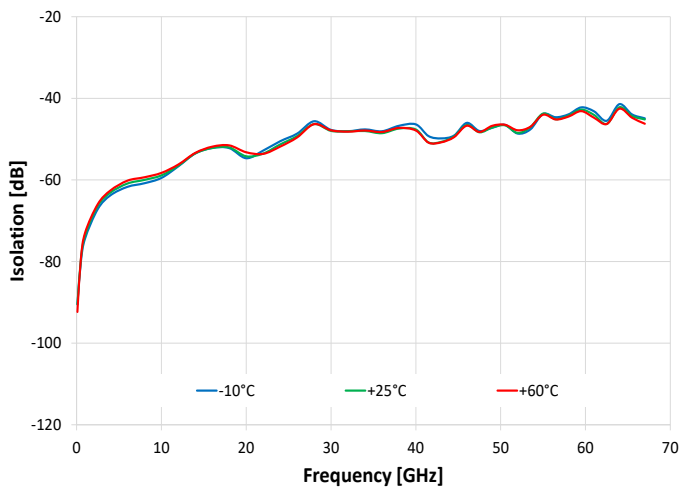

Isolation Com to 2 (1 Active)

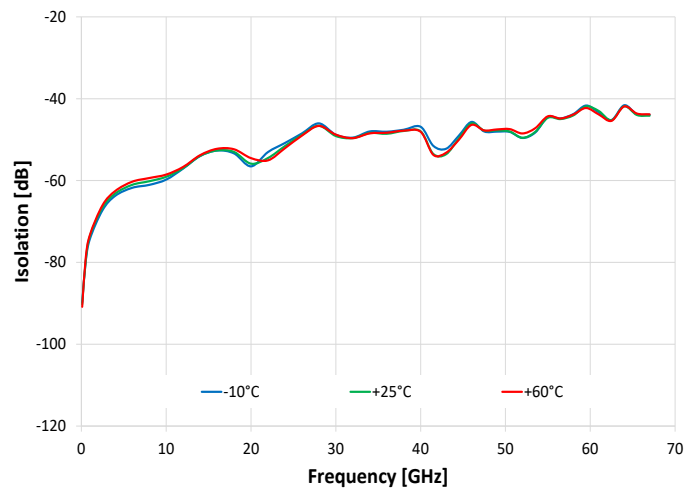

Isolation 1 to 2 (1 Active)

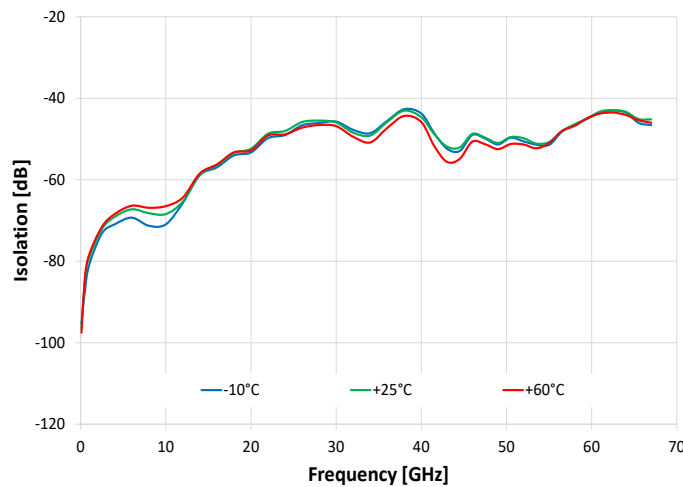



TYPICAL PERFORMANCE GRAPHS (CONTINUED)

Return Loss @ COM over Temperature (1 Active)

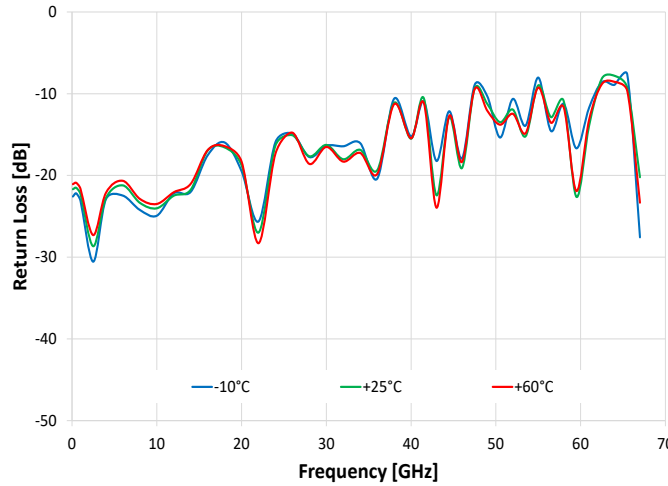

Return Loss @ 1 over Temperature (1 Active)

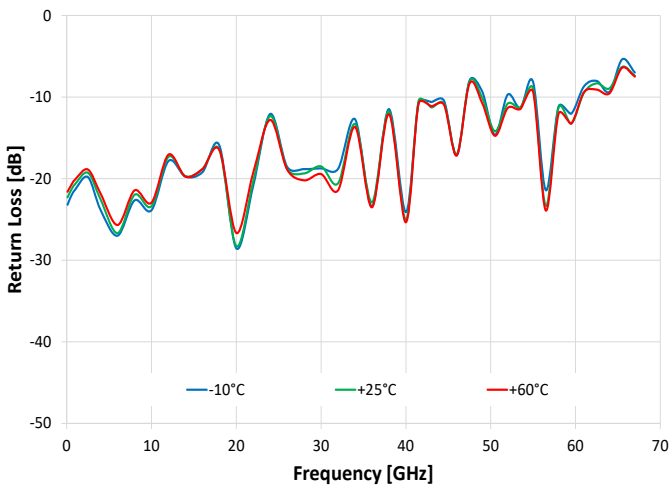

Return Loss @ 1 over Temperature (1 Terminated)

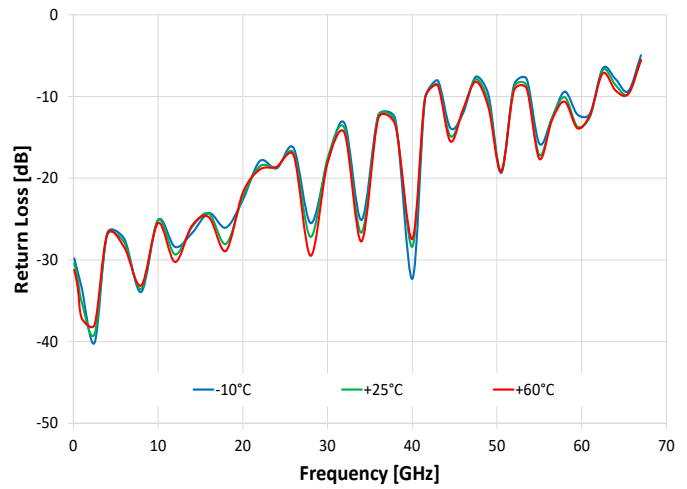

Return Loss @ 2 over Temperature (2 Active)

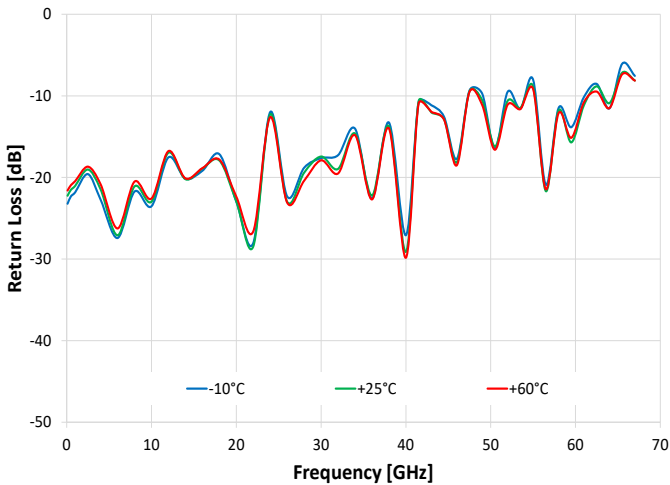

Return Loss @ 2 over Temperature (2 Terminated)

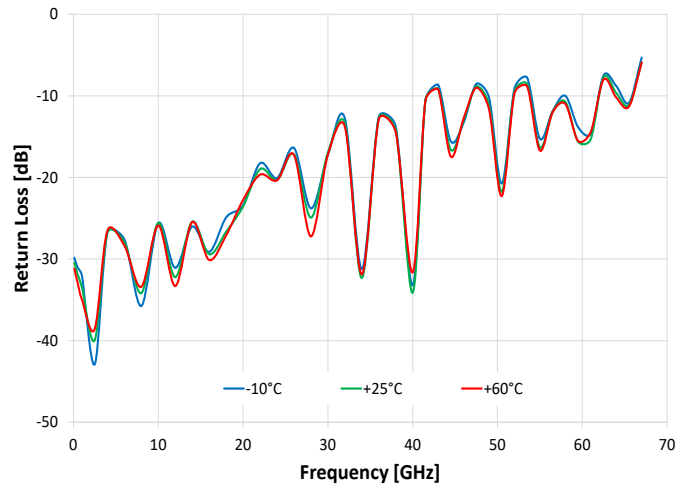



CONTROL INTERFACES

Ethernet Control	Supported Protocols	TCP / IP, HTTP, Telnet, SSH, DHCP, UDP (limited)
	Max Data Rate	100 Mbps (100 Base-T Full Duplex)
USB Control	Supported Protocols	HID (Human Interface Device) - High-speed
	Min Communication Time ⁷	400 μs typ (full transmit/receive cycle)

7. USB Min Communication Time is based on the polling interval of the USB HID protocol (125 μs polling interval, 64 bytes per packet), medium CPU load and no other high speed USB devices using the USB bus.

SOFTWARE & DOCUMENTATION

Mini-Circuits' full software and support package including user guide, Windows GUI, API, programming manual and examples can be downloaded free of charge (refer to the last page for the download path).

A comprehensive set of software control options is provided:

- GUI for Windows – Simple software interface for control via Ethernet and USB.
- Programming / automation via Ethernet:
 - Complete set of control commands which can be sent via any supported protocol.
 - Simple to implement in the majority of modern programming environments.
- Programming / automation via USB:
 - DLL files provide a full API for Windows with a set of intuitive functions which can be implemented in any programming environment supporting .Net Framework or ActiveX.
 - Direct USB programming is possible in any other environment (not supporting .Net or ActiveX).

Please contact testsolutions@minicircuits.com for support.

MINIMUM SYSTEM REQUIREMENTS

GUI	Windows 7 or later
USB API DLL	Windows 7 or later and programming environment with ActiveX or .NET support
USB Direct Programming	Linux, Windows 7 or later
Daisy-Chain Dynamic Addressing	An additional Mini-Circuits model supporting dynamic addressing
HTTP, Telnet or SSH	Any computer with a network port and Ethernet-TCP/IP (HTTP, Telnet or SSH protocols) support
Hardware	Intel i3 (or equivalent) or later



GRAPHICAL USER INTERFACE (GUI) FOR WINDOWS - KEY FEATURES

- Connect via USB
- Run GUI in "demo mode" to evaluate software without a hardware connection

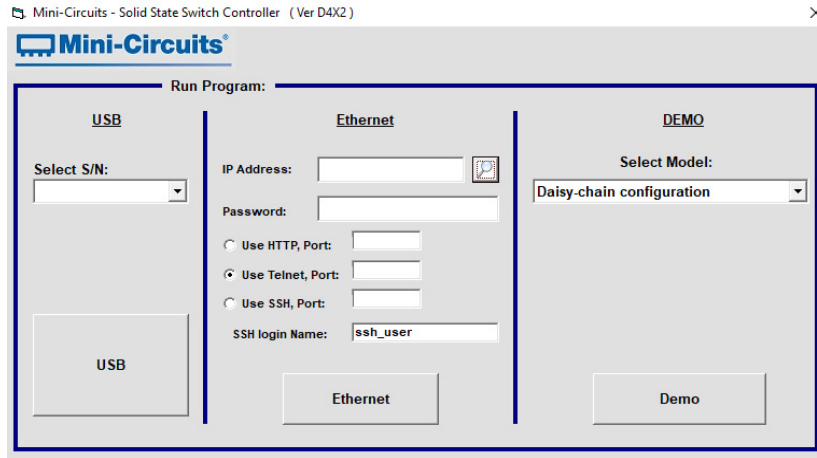

- View and set switch states at the click of a button
- Configure and run timed switching sequences

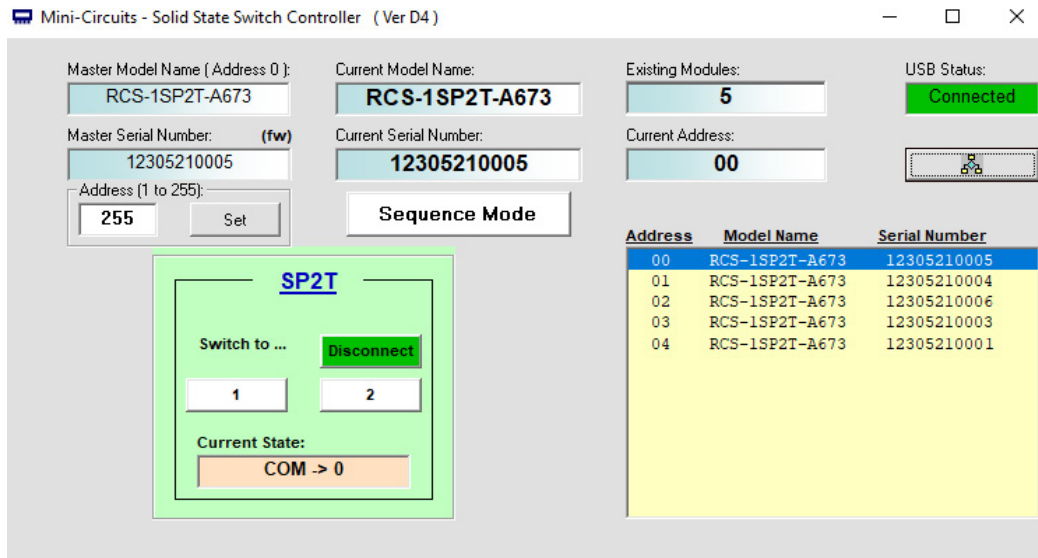



CONNECTING MULTIPLE MODULES (DAISY CHAIN)

The model is designed to connect up to 25 modules in series (daisy chain) using dynamic addressing, meaning there is no need to specifically set the address of the modules. The addresses will be set automatically as part of establishing the communications with the computer. The module connected to the computer's USB port will be assigned address 0 (master), the first module connected to it will get address 1 (slave) and subsequent modules incrementing up to address 24 (slave).

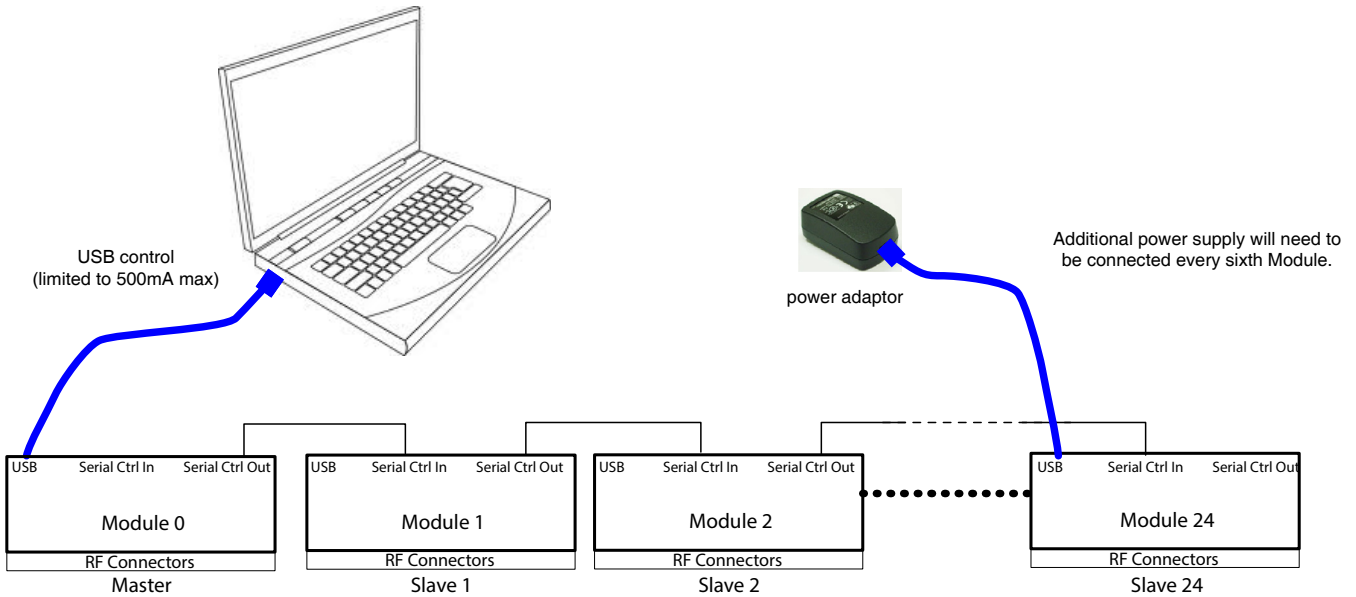

Connections between modules will be made using the serial in/out ports with the module connected to the PC act as a master and all other as slave modules. All control will be through the master module (address 0) which is the only one communicating with the PC. Serial control out port of each module should be connected to the serial control in port of the next module.

Power will be supplied from the PC via the master module up to a maximum of 500 mA. Generally, additional power supply will be needed to keep total current below 500 mA. All power supplies should be connected to the module via the module's USB port. Connecting an additional power supply will automatically cut off power draw from the serial control in port for that module.

The serial master/slave bus allows connecting modules of different types to the same daisy chain as long as all support Mini-Circuits Dynamic addressing setup. To add a new module to the setup, simply connect the module and refresh the address listing, no need to reset any of the existing modules or assign addresses manually.

Note: Different module types may have different current consumption which will change the number of units which can be connected before an additional power supply is needed. For example, if connecting units with a current consumption of 100 mA each, additional power supply is recommended every sixth module. If using units with current consumption of 50 mA additional power supply is recommended every eleventh module.



BLOCK DIAGRAM

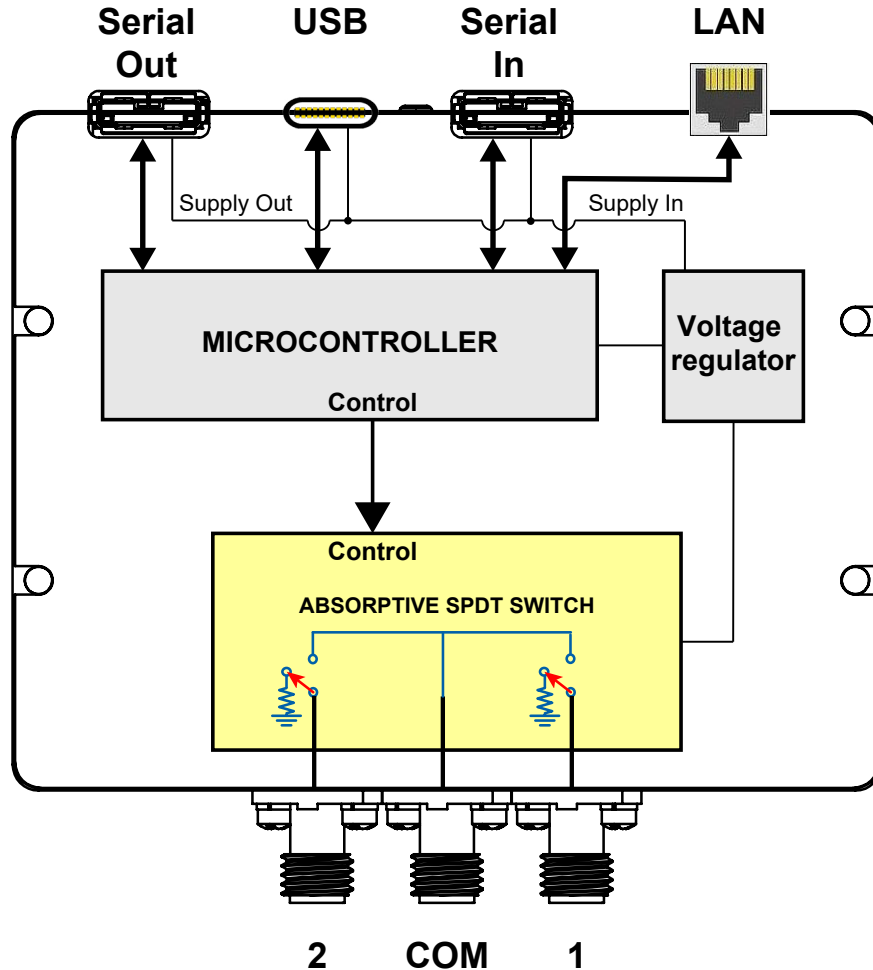

SWITCH STATE TABLE

State	Switch Path
0	All ports disconnected (COM Open, 1-2 Terminated)
1	Com to 1
2	Com to 2

CONNECTIONS

Port Name	Connector Type
RF Ports (COM, 1 and 2)	1.85 mm Female
USB	USB Type C Receptacle
LAN	RJ45 Socket
Serial In (digital control 2 port)	Digital Snap-Fit Connector ⁸
Serial Out (digital control 1 port)	Digital Snap-Fit Connector ⁸

8. Mating connector is Hirose ST40X-10S-CV(30).



CASE STYLE DRAWING (NR3502)

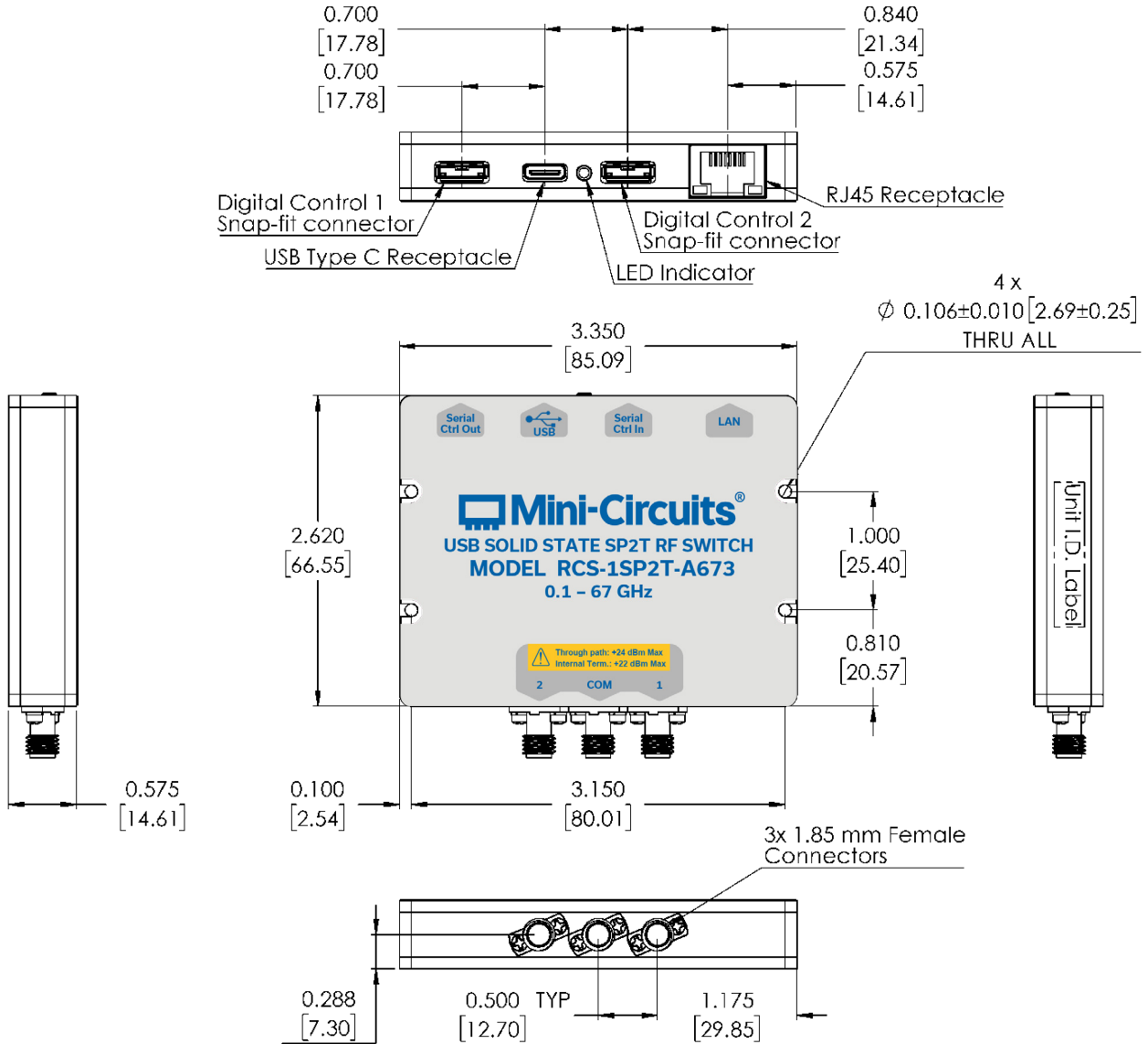

NOTES:

1. Case material: Aluminum alloy.
2. Case Finish: Nickel Plate.
3. Dimensions: Inches [mm].
Tolerances 2 Pl. ±.03 inch; 3 Pl. ±.015 inch.
4. Weight: 170 grams
5. Marking may contain other features or characters for internal lot control.



USB & ETHERNET

Solid-State Switch

RCS-1SP2T-A673



50Ω 0.1 to 67 GHz SP2T 1.85 mm female

DETAILED MODEL INFORMATION IS AVAILABLE ON OUR WEBSITE [CLICK HERE](#)

Performance Data & Graphs	Data Graphs
Case Style	NR3502
Environmental Rating	ENV55
Software, User Guide & Programming Manual	https://www.minicircuits.com/softwaredownload/solidstate.html
Regulatory Compliance	Refer to user guide for compliance information  https://www.minicircuits.com/app/AN49-012.pdf
Support	testsolutions@minicircuits.com

INCLUDED ACCESSORIES

	Part No.	Description
	USB-CBL-AC-3+	3.3 ft (1.0 m) USB cable: USB type A (Male) to USB type C (Male)

OPTIONAL ACCESSORIES

Part No.	Description
USB-CBL-AC-3+ (spare)	3.3 ft (1.0 m) USB Cable: USB type A (Male) to USB type C (Male)
CBL-1.5FT-MMD+	1.5 ft (0.45 m) Cable assembly for serial control daisy chain with snap fit connectors
CBL-RJ45-MM-5+	5.0 ft (1.5 m) Ethernet cable: RJ45 (Male) to RJ45 (Male) Cat 5E cable
USB-AC/DC-5	AC/DC +5V power adaptor with USB connector ^{9, 10}

9. The power adaptor may be used to provide additional power via USB port when connecting several units in daisy chain control.

10. Includes power plugs for US, UK, EU, IL, AU & China. Plugs for other countries are also available. If you need a power cord for a country not listed please contact testsolutions@minicircuits.com

NOTES:

- A. Performance and quality attributes and conditions not expressly stated in this specification document are intended to be excluded and do not form a part of this specification document.
- B. Electrical specifications and performance data contained in this specification document are based on Mini-Circuit's applicable established test performance criteria and measurement instructions.
- C. The parts covered by this specification document are subject to Mini-Circuits standard limited warranty and terms and conditions (collectively, "Standard Terms"); Purchasers of this part are entitled to the rights and benefits contained therein. For a full statement of the Standard Terms and the exclusive rights and remedies thereunder, please visit Mini-Circuits' website at <https://www.minicircuits.com/terms/viewterm.html>



SP2T Solid-State Switch

RCS-1SP2T-A673

Typical Performance Data

Test Conditions: @ Temperature = -10°C, Pin = 8 dBm.

Freq. (GHz)	Insertion Loss (dB)		Isolation, Active states (dB)			Isolation, Disconnected states (dB)		
	COM-1	COM-2	COM-1	COM-2	1-2	COM-1	COM-2	1-2
0.10	-0.70	-0.70	-90.52	-89.75	-95.29	-92.23	-92.74	-100.48
0.50	-0.79	-0.79	-80.26	-80.12	-87.38	-80.01	-77.70	-92.92
1.00	-0.86	-0.85	-74.39	-74.34	-80.96	-74.35	-71.12	-86.59
2.50	-1.02	-1.02	-67.15	-67.23	-73.16	-67.17	-64.09	-80.04
4.00	-1.12	-1.12	-63.76	-63.72	-70.94	-63.82	-61.06	-75.91
6.00	-1.24	-1.24	-61.69	-61.77	-69.31	-61.78	-59.30	-71.75
8.00	-1.37	-1.37	-60.81	-61.06	-71.29	-60.89	-58.75	-68.45
10.00	-1.45	-1.45	-59.51	-59.77	-70.95	-59.45	-58.50	-65.50
12.00	-1.63	-1.63	-56.66	-57.07	-65.70	-56.69	-56.71	-62.50
14.00	-1.75	-1.74	-53.50	-54.01	-58.88	-53.49	-53.95	-59.80
16.00	-1.94	-1.93	-52.15	-52.66	-56.96	-52.17	-52.77	-58.24
18.00	-2.17	-2.14	-52.20	-53.37	-54.03	-52.18	-54.05	-56.45
20.00	-2.23	-2.24	-54.68	-56.53	-53.31	-54.68	-57.13	-53.37
22.00	-2.33	-2.31	-52.81	-53.04	-49.80	-52.78	-57.79	-50.60
24.00	-2.67	-2.67	-50.52	-50.82	-49.03	-50.47	-59.92	-48.70
26.00	-2.62	-2.61	-48.65	-48.49	-46.63	-48.65	-59.18	-46.71
28.00	-2.79	-2.83	-45.62	-46.03	-46.08	-45.62	-53.26	-44.88
30.00	-2.88	-2.99	-47.74	-48.81	-45.74	-47.71	-50.25	-44.81
32.00	-2.88	-3.05	-48.06	-49.51	-47.76	-48.05	-50.16	-45.94
34.00	-3.16	-3.31	-47.62	-48.00	-48.57	-47.66	-49.06	-45.68
36.00	-3.11	-3.39	-48.07	-48.07	-45.53	-48.09	-48.78	-44.97
38.00	-3.72	-3.98	-46.74	-47.59	-42.68	-46.67	-47.96	-43.69
40.00	-3.50	-3.98	-46.39	-46.86	-43.76	-46.51	-47.63	-45.12
41.50	-3.90	-4.35	-49.26	-51.53	-48.53	-49.25	-49.08	-47.92
43.00	-3.90	-4.26	-49.82	-52.23	-52.36	-49.98	-51.62	-49.33
44.50	-3.98	-4.21	-49.13	-49.04	-52.96	-49.14	-52.31	-48.53
46.00	-3.82	-4.16	-46.02	-45.68	-48.99	-45.93	-51.24	-49.17
47.50	-4.81	-4.81	-48.01	-48.01	-49.91	-48.19	-50.01	-51.29
49.00	-4.57	-4.71	-47.21	-48.04	-51.34	-46.97	-48.97	-51.17
50.50	-4.17	-4.27	-46.50	-48.11	-49.68	-46.38	-47.53	-52.22
52.00	-4.66	-4.86	-48.63	-49.59	-50.59	-48.43	-46.69	-60.21
53.50	-4.72	-4.90	-47.62	-48.28	-51.40	-47.46	-45.38	-70.78
55.00	-5.37	-5.56	-43.84	-44.53	-51.45	-43.83	-42.60	-73.90
56.50	-4.72	-4.85	-44.64	-44.83	-48.24	-44.72	-41.71	-68.17
58.00	-5.10	-5.13	-43.93	-43.76	-46.55	-43.93	-42.37	-64.43
59.50	-4.98	-4.95	-42.22	-41.67	-44.87	-42.18	-43.91	-58.42
61.00	-5.74	-5.61	-43.18	-43.34	-43.39	-43.18	-46.23	-54.62
62.50	-6.17	-6.19	-45.51	-45.20	-43.03	-45.47	-48.66	-54.20
64.00	-6.41	-6.27	-41.43	-41.60	-43.50	-41.34	-47.44	-52.54
65.50	-7.46	-7.21	-43.96	-43.80	-46.04	-44.02	-44.81	-53.12
67.00	-6.89	-6.67	-44.91	-43.93	-46.59	-45.14	-44.27	-57.42

SP2T Solid-State Switch

RCS-1SP2T-A673

Typical Performance Data

Test Conditions: @ Temperature = -10°C, Pin = 8 dBm.

Freq. (GHz)	Return Loss, Active ports (dB)			RL, Terminated ports (dB)	
	COM	1	2	1	2
0.10	-22.58	-23.20	-23.22	-29.81	-29.84
0.50	-22.20	-22.19	-22.31	-31.41	-31.05
1.00	-23.12	-21.34	-21.82	-33.50	-32.05
2.50	-30.55	-19.81	-19.59	-40.13	-42.90
4.00	-22.91	-23.85	-22.73	-26.73	-26.77
6.00	-22.47	-26.99	-27.42	-27.40	-27.58
8.00	-24.22	-22.67	-21.73	-33.93	-35.75
10.00	-24.93	-23.87	-23.53	-25.12	-25.59
12.00	-22.19	-17.84	-17.54	-28.41	-31.07
14.00	-22.01	-19.74	-20.15	-26.72	-26.02
16.00	-17.54	-19.22	-19.18	-24.27	-29.12
18.00	-15.97	-15.92	-17.15	-26.05	-24.91
20.00	-19.48	-28.54	-22.96	-22.66	-23.39
22.00	-25.63	-20.86	-28.03	-17.91	-18.26
24.00	-15.91	-12.07	-11.98	-18.79	-20.08
26.00	-14.87	-18.56	-22.33	-16.32	-16.39
28.00	-17.75	-18.83	-18.81	-25.49	-23.79
30.00	-16.36	-18.74	-17.63	-18.07	-17.23
32.00	-16.43	-18.80	-17.27	-13.26	-12.77
34.00	-16.05	-12.72	-14.02	-25.11	-31.22
36.00	-20.40	-23.39	-22.57	-12.26	-12.56
38.00	-10.61	-11.48	-13.27	-12.74	-13.77
40.00	-15.21	-24.10	-27.08	-32.33	-33.22
41.50	-10.94	-10.72	-10.76	-10.38	-10.59
43.00	-18.23	-10.61	-11.15	-8.03	-8.65
44.50	-12.15	-10.46	-12.57	-13.85	-15.58
46.00	-17.92	-17.13	-17.72	-12.04	-13.30
47.50	-8.91	-7.98	-9.34	-7.59	-8.53
49.00	-10.34	-9.33	-9.74	-9.80	-10.19
50.50	-15.36	-14.63	-16.46	-19.35	-20.74
52.00	-10.64	-9.71	-9.50	-8.62	-9.11
53.50	-13.91	-11.32	-11.56	-7.84	-7.78
55.00	-8.03	-8.17	-8.02	-15.77	-15.25
56.50	-14.56	-21.42	-20.89	-12.63	-11.87
58.00	-11.24	-11.16	-11.49	-9.41	-10.00
59.50	-16.68	-12.03	-13.84	-12.21	-13.83
61.00	-11.71	-8.69	-10.13	-12.08	-14.59
62.50	-8.60	-8.03	-8.54	-6.54	-7.51
64.00	-8.91	-9.37	-11.53	-7.87	-8.79
65.50	-7.65	-5.38	-6.07	-9.36	-10.85
67.00	-27.57	-7.00	-7.55	-4.96	-5.31

SP2T Solid-State Switch

RCS-1SP2T-A673

Typical Performance Data

Test Conditions: @ Temperature = +25°C, Pin = 8 dBm.

Freq. (GHz)	Insertion Loss (dB)		Isolation, Active states (dB)			Isolation, Disconnected states (dB)		
	COM-1	COM-2	COM-1	COM-2	1-2	COM-1	COM-2	1-2
0.10	-0.78	-0.79	-90.45	-90.22	-96.39	-89.75	-90.98	-103.40
0.50	-0.88	-0.90	-79.58	-79.94	-84.40	-76.94	-76.93	-94.48
1.00	-0.96	-0.97	-73.61	-73.59	-79.17	-70.59	-70.84	-88.00
2.50	-1.15	-1.17	-66.37	-66.56	-72.09	-63.26	-63.17	-80.49
4.00	-1.25	-1.28	-63.09	-63.16	-69.11	-60.14	-60.06	-75.38
6.00	-1.39	-1.41	-60.88	-61.04	-67.26	-58.12	-58.11	-71.75
8.00	-1.52	-1.56	-59.99	-60.17	-68.20	-57.35	-57.39	-68.44
10.00	-1.61	-1.64	-58.89	-59.08	-68.43	-56.89	-57.04	-65.55
12.00	-1.81	-1.85	-56.50	-56.96	-65.35	-55.55	-55.88	-62.55
14.00	-1.94	-1.98	-53.50	-53.98	-58.74	-53.11	-53.67	-59.88
16.00	-2.15	-2.19	-52.18	-52.64	-56.55	-51.98	-52.49	-58.12
18.00	-2.37	-2.40	-52.04	-53.01	-53.43	-52.80	-53.42	-56.36
20.00	-2.46	-2.53	-54.21	-55.88	-52.39	-55.54	-56.15	-52.98
22.00	-2.58	-2.61	-53.54	-54.50	-48.70	-57.42	-57.71	-49.71
24.00	-2.92	-2.99	-51.31	-51.58	-48.04	-64.50	-60.28	-47.59
26.00	-2.90	-2.95	-49.26	-48.84	-45.84	-61.53	-60.49	-45.72
28.00	-3.07	-3.18	-46.32	-46.62	-45.50	-54.11	-54.40	-44.20
30.00	-3.17	-3.36	-47.98	-49.12	-45.95	-50.49	-50.97	-44.59
32.00	-3.16	-3.39	-48.07	-49.63	-48.45	-49.42	-50.15	-45.98
34.00	-3.45	-3.69	-48.01	-48.38	-49.16	-48.42	-49.01	-45.81
36.00	-3.46	-3.82	-48.54	-48.57	-45.79	-48.55	-48.73	-44.66
38.00	-4.06	-4.40	-47.41	-47.88	-43.04	-49.40	-48.09	-43.64
40.00	-3.87	-4.39	-47.64	-47.97	-44.67	-50.30	-47.72	-45.49
41.50	-4.34	-4.81	-50.82	-53.51	-48.79	-51.21	-49.09	-47.76
43.00	-4.25	-4.64	-50.67	-53.57	-51.85	-51.55	-51.13	-49.14
44.50	-4.34	-4.64	-49.35	-49.71	-52.08	-50.19	-51.84	-48.65
46.00	-4.24	-4.62	-46.54	-46.01	-48.73	-48.78	-51.20	-49.08
47.50	-5.24	-5.32	-48.32	-47.80	-49.68	-49.76	-50.24	-51.27
49.00	-4.94	-5.18	-47.17	-47.75	-50.98	-49.76	-49.20	-51.63
50.50	-4.68	-4.86	-46.61	-48.01	-49.53	-48.03	-47.84	-53.78
52.00	-5.04	-5.35	-48.49	-49.55	-49.82	-47.41	-46.75	-60.73
53.50	-5.22	-5.51	-47.05	-48.12	-51.13	-45.49	-45.23	-66.72
55.00	-5.76	-6.06	-43.74	-44.66	-50.76	-43.18	-42.68	-66.66
56.50	-5.26	-5.50	-45.12	-44.97	-48.08	-42.36	-41.63	-64.66
58.00	-5.55	-5.73	-44.23	-44.08	-46.36	-44.17	-42.47	-62.25
59.50	-5.37	-5.48	-42.77	-41.88	-45.05	-46.46	-44.04	-60.48
61.00	-6.09	-6.09	-44.06	-43.00	-43.27	-48.48	-45.54	-57.04
62.50	-6.74	-6.89	-46.28	-45.26	-42.92	-51.24	-48.23	-55.79
64.00	-7.18	-7.10	-42.19	-41.85	-43.32	-48.81	-47.31	-52.96
65.50	-7.66	-7.49	-44.35	-43.98	-45.11	-45.85	-44.96	-52.27
67.00	-7.45	-7.32	-45.17	-44.15	-45.18	-47.60	-45.66	-54.75

SP2T Solid-State Switch

RCS-1SP2T-A673

Typical Performance Data

Test Conditions: @ Temperature = +25°C, Pin = 8 dBm.

Freq. (GHz)	Return Loss, Active ports (dB)			RL, Terminated ports (dB)	
	COM	1	2	1	2
0.10	-21.69	-22.30	-22.24	-30.44	-30.46
0.50	-21.52	-21.44	-21.51	-32.21	-31.91
1.00	-22.29	-20.66	-21.03	-35.23	-33.49
2.50	-28.66	-19.28	-19.03	-39.06	-39.95
4.00	-22.77	-22.56	-21.47	-26.97	-26.78
6.00	-21.22	-26.68	-27.09	-27.85	-27.93
8.00	-23.35	-21.98	-21.10	-33.55	-34.17
10.00	-24.02	-23.37	-22.97	-25.10	-25.57
12.00	-22.48	-17.32	-16.96	-29.33	-32.22
14.00	-21.75	-19.70	-20.21	-25.98	-25.42
16.00	-16.96	-18.83	-18.91	-24.32	-29.41
18.00	-16.57	-16.44	-17.92	-28.05	-26.66
20.00	-18.76	-28.27	-22.94	-22.31	-23.55
22.00	-26.99	-20.29	-28.46	-18.55	-18.98
24.00	-16.34	-12.33	-12.27	-18.65	-20.30
26.00	-15.08	-18.82	-22.98	-16.96	-17.17
28.00	-17.66	-19.36	-19.41	-27.19	-24.92
30.00	-16.27	-18.50	-17.44	-17.58	-16.94
32.00	-18.02	-20.57	-18.95	-13.88	-13.39
34.00	-16.87	-13.30	-14.61	-26.67	-32.32
36.00	-19.37	-22.90	-22.21	-12.32	-12.71
38.00	-11.11	-11.75	-13.73	-13.15	-14.21
40.00	-15.50	-25.04	-29.12	-28.39	-34.13
41.50	-10.55	-10.45	-10.66	-10.17	-10.51
43.00	-22.43	-11.27	-12.03	-8.52	-9.13
44.50	-12.85	-10.82	-12.89	-14.85	-16.62
46.00	-19.10	-17.00	-18.15	-11.68	-13.00
47.50	-9.35	-8.11	-9.44	-7.88	-8.83
49.00	-11.27	-10.09	-10.56	-10.69	-11.07
50.50	-13.49	-14.19	-16.20	-19.09	-21.74
52.00	-11.94	-10.81	-10.60	-8.89	-9.45
53.50	-15.22	-11.26	-11.48	-8.64	-8.53
55.00	-8.98	-8.97	-8.86	-17.17	-16.32
56.50	-12.87	-23.34	-21.68	-12.67	-12.02
58.00	-10.89	-11.30	-11.79	-10.09	-10.73
59.50	-22.62	-13.26	-15.70	-13.70	-15.62
61.00	-13.92	-9.47	-11.13	-12.45	-15.30
62.50	-8.15	-8.32	-8.83	-6.76	-7.74
64.00	-7.81	-8.94	-10.89	-8.60	-9.64
65.50	-9.26	-6.30	-7.16	-9.73	-11.12
67.00	-20.22	-7.39	-8.12	-5.55	-5.94

SP2T Solid-State Switch

RCS-1SP2T-A673

Typical Performance Data

Test Conditions: @ Temperature = +60°C, Pin = 8 dBm.

Freq. (GHz)	Insertion Loss (dB)		Isolation, Active states (dB)			Isolation, Disconnected states (dB)		
	COM-1	COM-2	COM-1	COM-2	1-2	COM-1	COM-2	1-2
0.10	-0.85	-0.86	-92.35	-90.86	-97.55	-91.62	-87.64	-98.37
0.50	-0.96	-0.97	-79.46	-79.13	-84.11	-79.32	-76.27	-92.96
1.00	-1.04	-1.05	-72.94	-73.31	-78.40	-73.26	-69.95	-87.66
2.50	-1.24	-1.25	-65.93	-66.00	-71.56	-66.11	-62.47	-81.52
4.00	-1.36	-1.37	-62.57	-62.54	-68.43	-62.63	-59.36	-76.25
6.00	-1.51	-1.51	-60.18	-60.28	-66.38	-60.31	-57.24	-71.79
8.00	-1.65	-1.66	-59.35	-59.39	-66.88	-59.47	-56.36	-68.60
10.00	-1.75	-1.76	-58.28	-58.54	-66.48	-58.60	-55.97	-65.76
12.00	-1.96	-1.97	-56.22	-56.67	-64.37	-56.68	-55.13	-62.75
14.00	-2.10	-2.11	-53.37	-53.80	-58.44	-53.83	-53.27	-60.40
16.00	-2.32	-2.32	-51.85	-52.24	-56.25	-52.28	-51.96	-58.71
18.00	-2.56	-2.55	-51.54	-52.36	-53.28	-52.36	-52.66	-57.21
20.00	-2.66	-2.69	-53.22	-54.52	-52.82	-54.58	-55.23	-54.40
22.00	-2.80	-2.77	-53.61	-55.07	-49.14	-55.11	-57.20	-50.93
24.00	-3.12	-3.15	-51.84	-52.10	-48.87	-52.10	-59.92	-48.76
26.00	-3.14	-3.14	-49.59	-49.03	-47.22	-49.02	-62.06	-46.81
28.00	-3.29	-3.36	-46.33	-46.65	-46.57	-46.68	-55.31	-45.09
30.00	-3.40	-3.54	-47.84	-48.78	-46.84	-48.81	-51.15	-45.25
32.00	-3.41	-3.60	-48.17	-49.64	-49.45	-49.55	-49.80	-46.47
34.00	-3.71	-3.90	-47.89	-48.47	-50.84	-48.50	-48.65	-46.40
36.00	-3.72	-4.03	-48.26	-48.32	-47.29	-48.22	-48.40	-45.62
38.00	-4.31	-4.59	-47.26	-47.82	-44.34	-47.91	-47.82	-44.25
40.00	-4.16	-4.59	-47.89	-48.09	-45.85	-48.05	-47.53	-45.70
41.50	-4.60	-4.97	-50.87	-53.73	-51.67	-53.44	-49.08	-48.80
43.00	-4.58	-4.86	-50.78	-53.20	-55.61	-53.33	-50.74	-50.07
44.50	-4.67	-4.87	-49.52	-50.06	-54.89	-50.26	-51.42	-49.15
46.00	-4.56	-4.84	-46.71	-46.40	-50.64	-46.33	-51.69	-49.70
47.50	-5.52	-5.53	-48.24	-47.75	-51.30	-47.87	-50.48	-51.35
49.00	-5.18	-5.34	-46.74	-47.51	-52.49	-47.63	-49.19	-51.70
50.50	-4.99	-5.08	-46.48	-47.43	-51.24	-47.54	-47.50	-54.14
52.00	-5.36	-5.55	-47.83	-48.49	-51.34	-48.53	-46.13	-63.14
53.50	-5.58	-5.75	-46.97	-47.22	-52.28	-47.28	-44.60	-69.95
55.00	-6.03	-6.22	-44.02	-44.30	-51.01	-44.35	-42.37	-72.85
56.50	-5.57	-5.71	-45.18	-44.83	-48.05	-44.95	-41.76	-69.09
58.00	-5.86	-5.91	-44.47	-43.87	-46.77	-43.85	-42.99	-66.40
59.50	-5.76	-5.74	-43.14	-42.27	-44.90	-42.31	-44.48	-60.56
61.00	-6.48	-6.39	-44.75	-43.85	-43.77	-43.81	-46.20	-57.72
62.50	-7.00	-7.09	-46.29	-45.41	-43.51	-45.64	-48.65	-55.87
64.00	-7.44	-7.34	-42.54	-41.89	-44.09	-41.97	-47.39	-53.61
65.50	-8.14	-7.88	-44.77	-43.63	-45.40	-43.62	-45.07	-54.62
67.00	-7.83	-7.63	-46.23	-43.82	-46.00	-43.82	-44.96	-57.73

NOTES:

- A. Performance and quality attributes and conditions not expressly stated in this specification document are intended to be excluded and do not form a part of this specification document.
- B. Electrical specifications and performance data contained in this specification document are based on Mini-Circuits' applicable established test performance criteria and measurement instructions.
- C. The parts covered by this specification document are subject to Mini-Circuits standard limited warranty and terms and conditions (collectively, "Standard Terms"); Purchasers of this part are entitled to the rights and benefits contained therein. For a full statement of the Standard Terms and the exclusive rights and remedies thereunder, please visit Mini-Circuits' website at <https://www.minicircuits.com/terms/viewterm.html>



SP2T Solid-State Switch

RCS-1SP2T-A673

Typical Performance Data

Test Conditions: @ Temperature = +60°C, Pin = 8 dBm.

Freq. (GHz)	Return Loss, Active ports (dB)			RL, Terminated ports (dB)	
	COM	1	2	1	2
0.10	-21.07	-21.61	-21.60	-31.21	-31.18
0.50	-20.91	-20.85	-20.94	-33.29	-32.96
1.00	-21.64	-20.10	-20.45	-37.18	-34.98
2.50	-27.30	-18.88	-18.68	-37.93	-38.58
4.00	-22.13	-21.84	-20.84	-26.83	-26.52
6.00	-20.66	-25.68	-26.25	-28.46	-28.35
8.00	-22.87	-21.44	-20.51	-33.13	-33.40
10.00	-23.49	-22.94	-22.58	-25.49	-25.89
12.00	-22.06	-17.06	-16.77	-30.26	-33.31
14.00	-21.03	-19.75	-20.11	-25.81	-25.47
16.00	-16.90	-18.83	-18.86	-24.78	-30.11
18.00	-16.42	-16.49	-17.81	-28.90	-27.10
20.00	-18.30	-26.66	-22.35	-21.77	-22.75
22.00	-28.29	-19.25	-26.61	-18.94	-19.66
24.00	-17.33	-12.80	-12.61	-18.62	-20.35
26.00	-14.77	-18.89	-23.09	-17.20	-17.24
28.00	-18.59	-20.21	-20.40	-29.49	-27.22
30.00	-16.51	-19.44	-17.90	-18.12	-17.20
32.00	-18.31	-21.43	-19.51	-14.46	-13.79
34.00	-17.25	-13.67	-14.82	-27.74	-31.87
36.00	-19.83	-23.51	-22.69	-12.65	-12.90
38.00	-11.28	-12.10	-14.00	-13.50	-14.48
40.00	-15.45	-25.35	-29.84	-27.44	-31.64
41.50	-11.14	-10.76	-10.93	-10.28	-10.60
43.00	-23.95	-11.13	-11.96	-8.62	-9.20
44.50	-12.71	-10.96	-12.92	-15.50	-17.45
46.00	-18.35	-17.16	-18.51	-11.57	-12.79
47.50	-9.44	-8.35	-9.51	-8.19	-9.00
49.00	-12.10	-10.75	-11.14	-11.36	-11.64
50.50	-13.79	-14.75	-16.60	-19.22	-22.28
52.00	-12.46	-11.35	-11.08	-9.30	-9.71
53.50	-14.84	-11.46	-11.62	-9.02	-8.85
55.00	-9.25	-9.39	-9.18	-17.63	-16.70
56.50	-13.55	-23.91	-21.44	-12.90	-12.01
58.00	-11.67	-12.06	-12.13	-10.63	-10.99
59.50	-21.91	-13.23	-15.14	-13.89	-15.53
61.00	-13.18	-9.40	-10.77	-12.17	-14.42
62.50	-8.84	-9.09	-9.48	-7.16	-8.01
64.00	-8.55	-9.55	-11.50	-9.27	-10.20
65.50	-9.66	-6.41	-7.36	-9.66	-11.31
67.00	-23.33	-7.50	-8.13	-5.53	-5.90

NOTES:

- A. Performance and quality attributes and conditions not expressly stated in this specification document are intended to be excluded and do not form a part of this specification document.
- B. Electrical specifications and performance data contained in this specification document are based on Mini-Circuits' applicable established test performance criteria and measurement instructions.
- C. The parts covered by this specification document are subject to Mini-Circuits standard limited warranty and terms and conditions (collectively, "Standard Terms"); Purchasers of this part are entitled to the rights and benefits contained therein. For a full statement of the Standard Terms and the exclusive rights and remedies thereunder, please visit Mini-Circuits' website at <https://www.minicircuits.com/terms/viewterm.html>



SP2T Solid-State Switch

RCS-1SP2T-A673

Typical Performance Graphs

Test Conditions: @ Temperature = -10°C, Pin = 8 dBm.

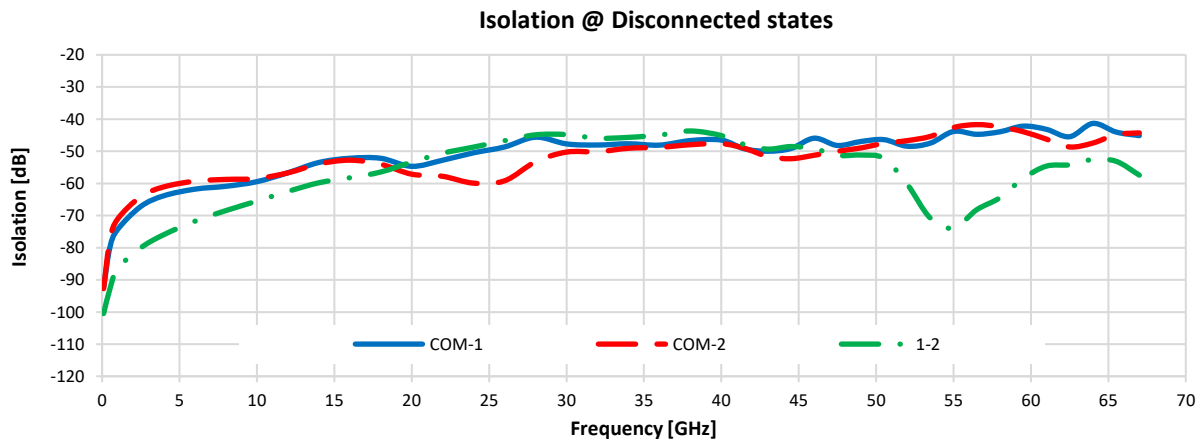
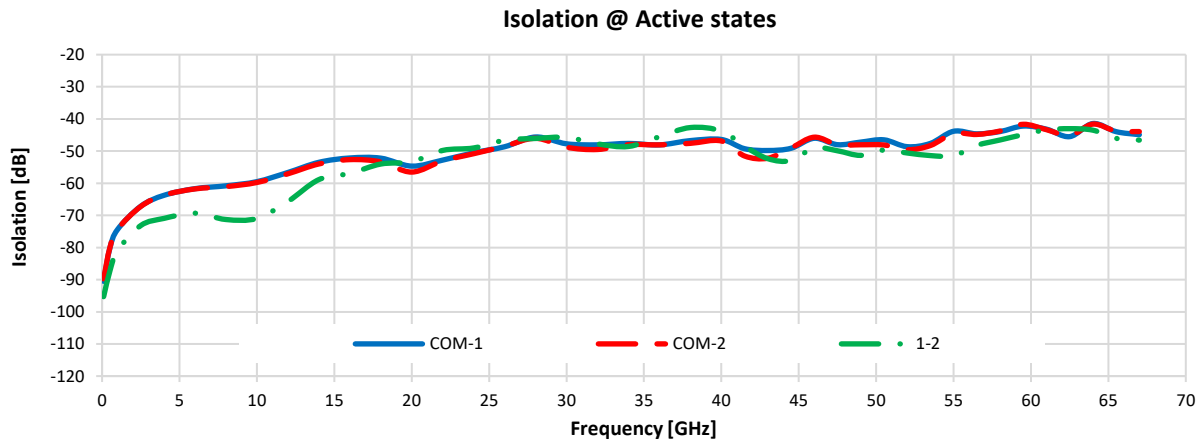
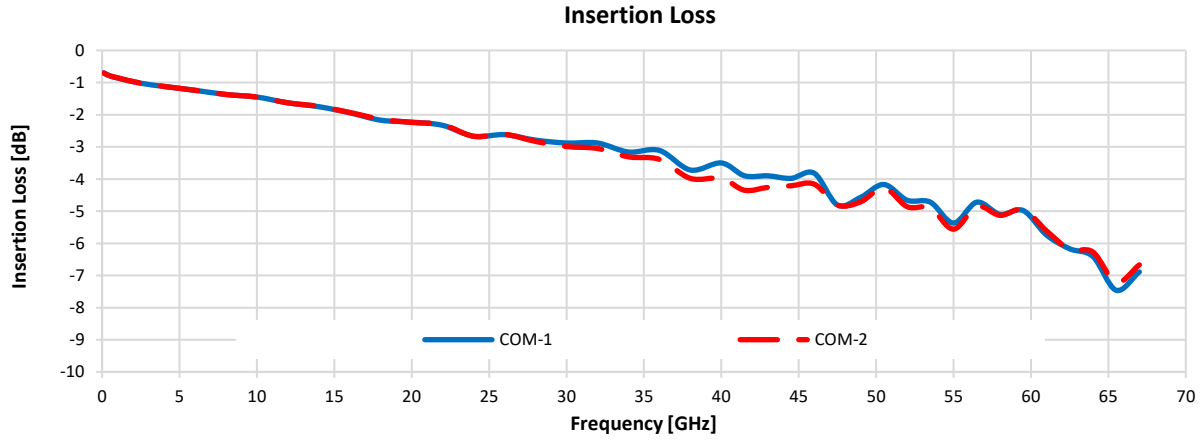

SP2T Solid-State Switch

RCS-1SP2T-A673

Typical Performance Graphs

Test Conditions: @ Temperature = -10°C, Pin = 8 dBm.

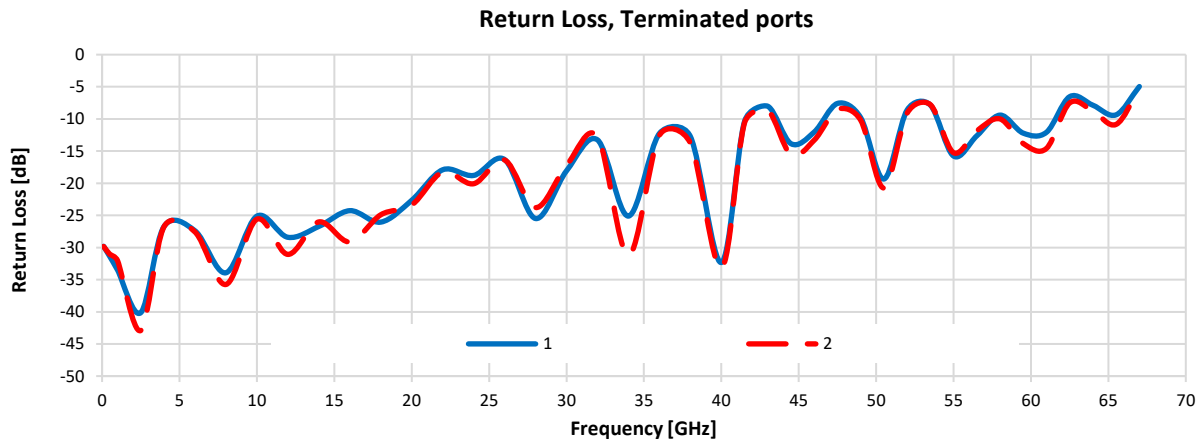
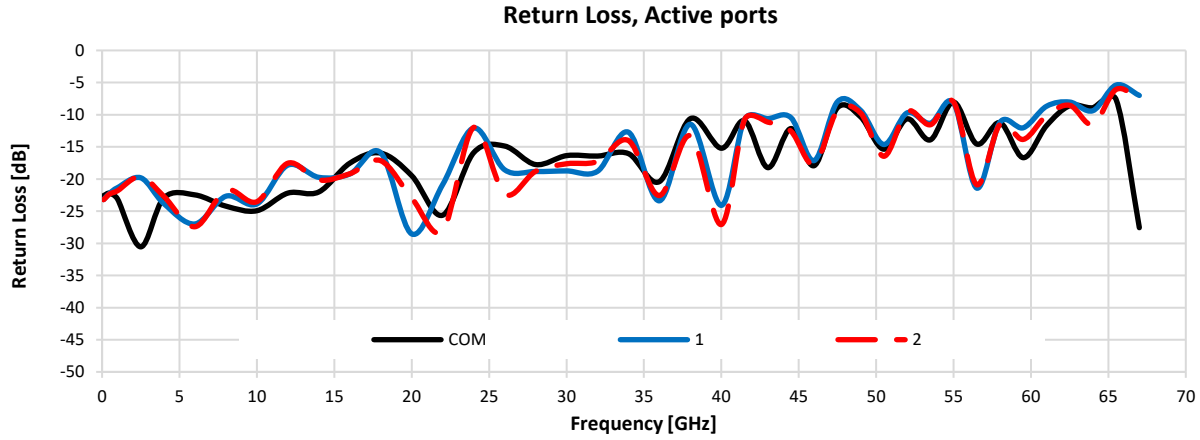

SP2T Solid-State Switch

RCS-1SP2T-A673

Typical Performance Graphs

Test Conditions: @ Temperature = +25°C, Pin = 8 dBm.

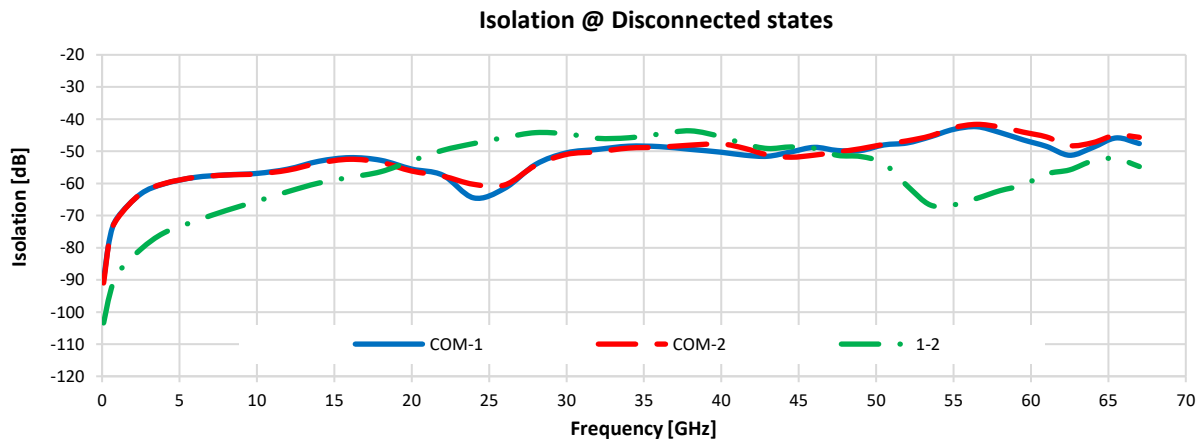
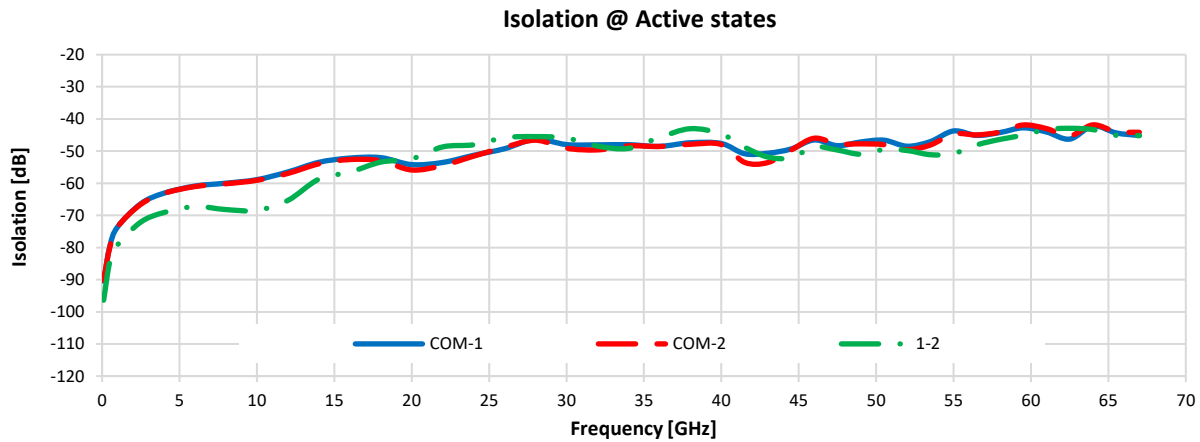
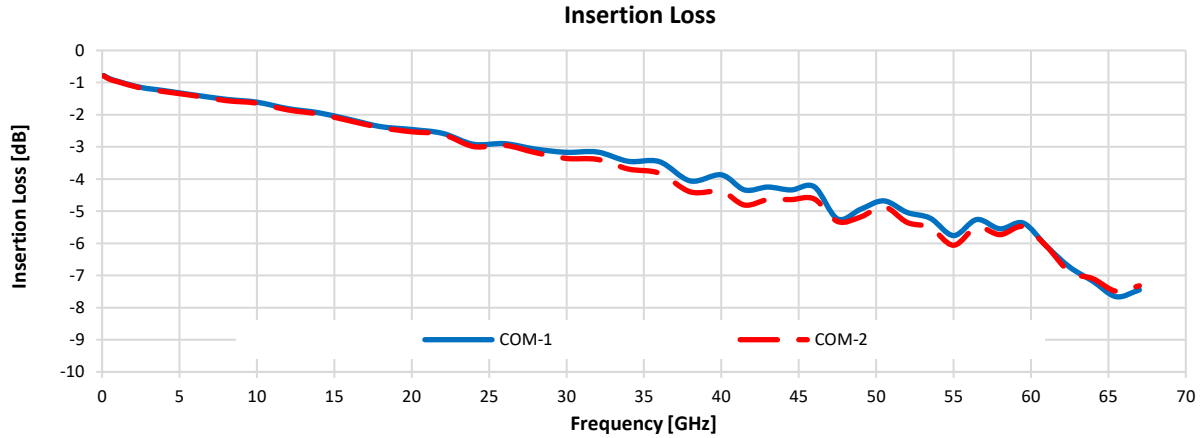

SP2T Solid-State Switch

RCS-1SP2T-A673

Typical Performance Graphs

Test Conditions: @ Temperature = +25°C, Pin = 8 dBm.

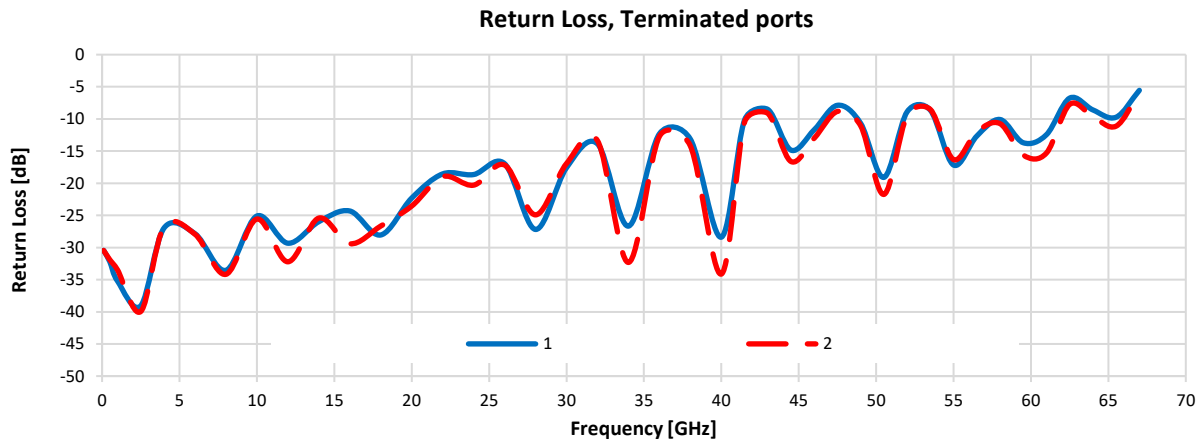
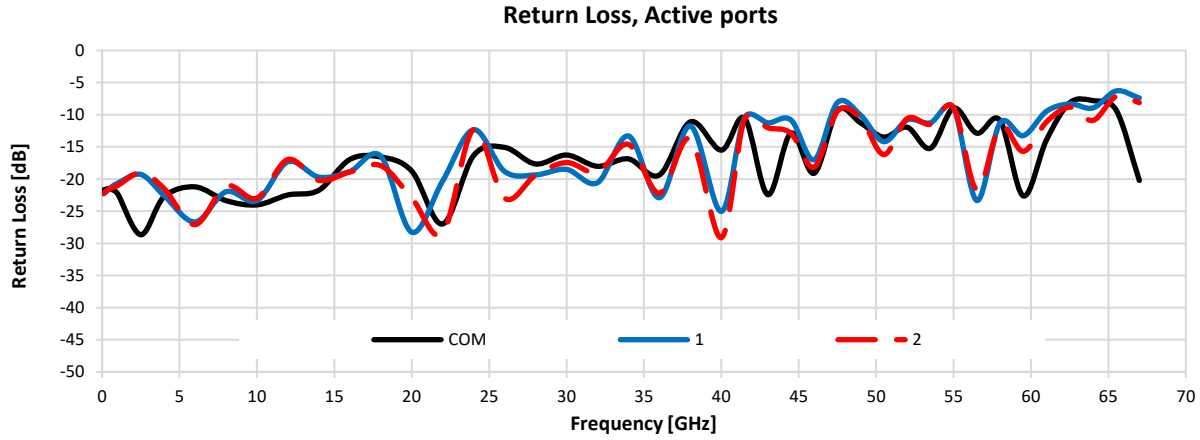

SP2T Solid-State Switch

RCS-1SP2T-A673

Typical Performance Graphs

Test Conditions: @ Temperature = +60°C, Pin = 8 dBm.

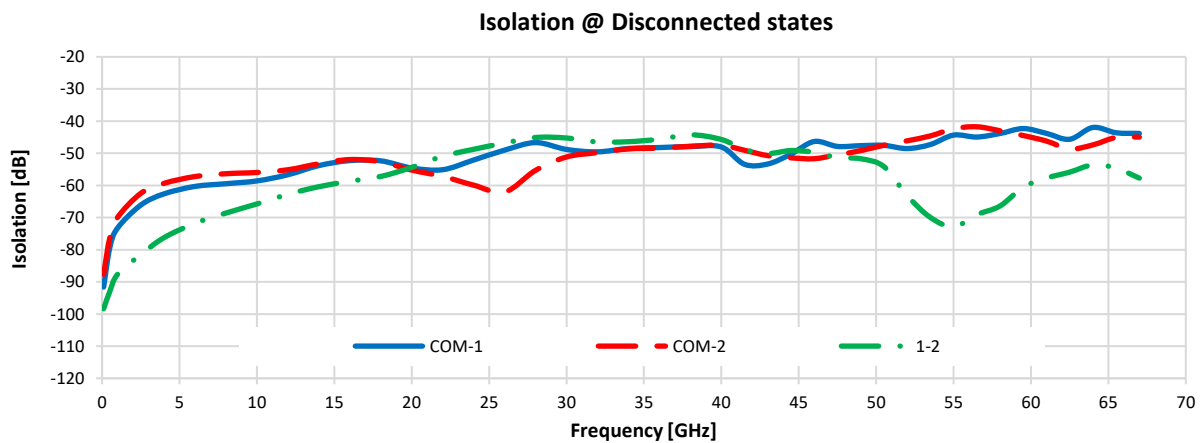
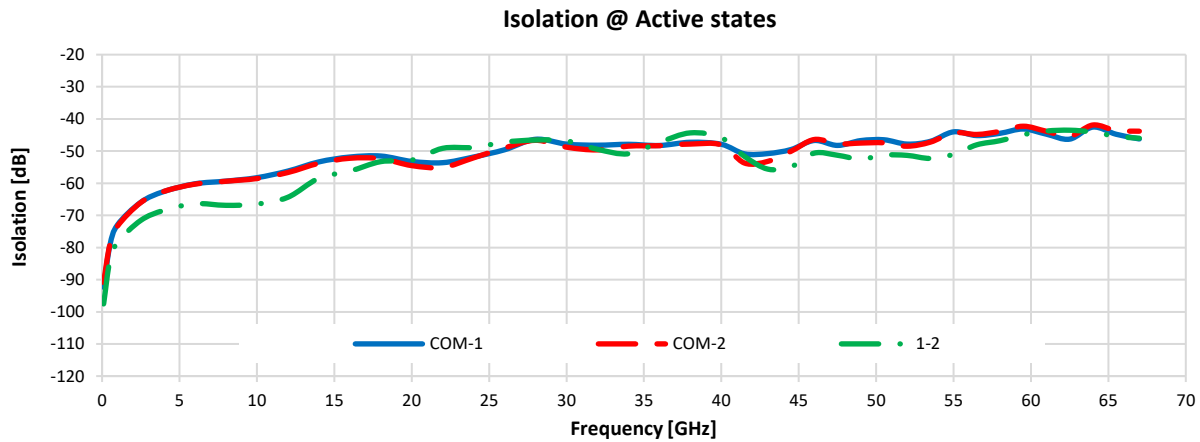
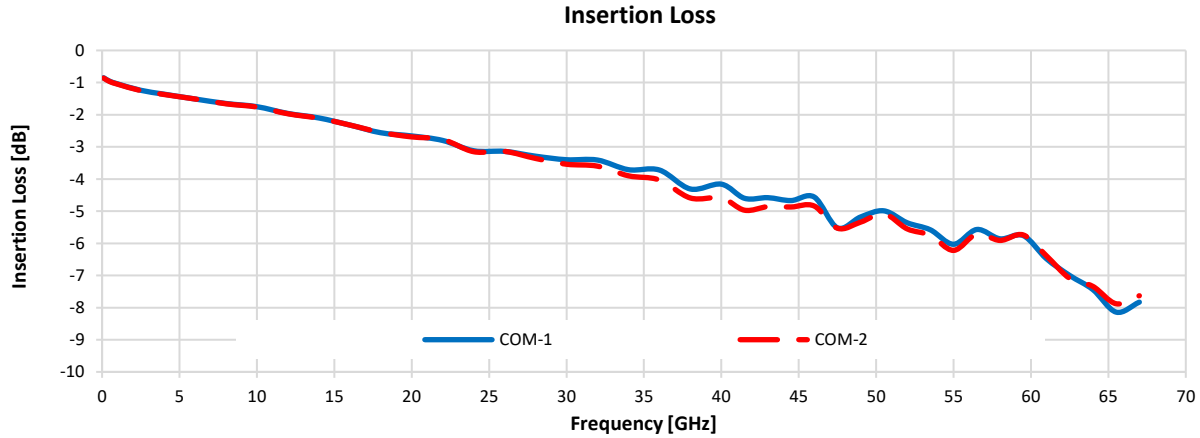

NOTES:

- A. Performance and quality attributes and conditions not expressly stated in this specification document are intended to be excluded and do not form a part of this specification document.
- B. Electrical specifications and performance data contained in this specification document are based on Mini-Circuits' applicable established test performance criteria and measurement instructions.
- C. The parts covered by this specification document are subject to Mini-Circuits standard limited warranty and terms and conditions (collectively, "Standard Terms"); Purchasers of this part are entitled to the rights and benefits contained therein. For a full statement of the Standard Terms and the exclusive rights and remedies thereunder, please visit Mini-Circuits' website at <https://www.minicircuits.com/terms/viewterm.html>



SP2T Solid-State Switch

RCS-1SP2T-A673

Typical Performance Graphs

Test Conditions: @ Temperature = +60°C, Pin = 8 dBm.

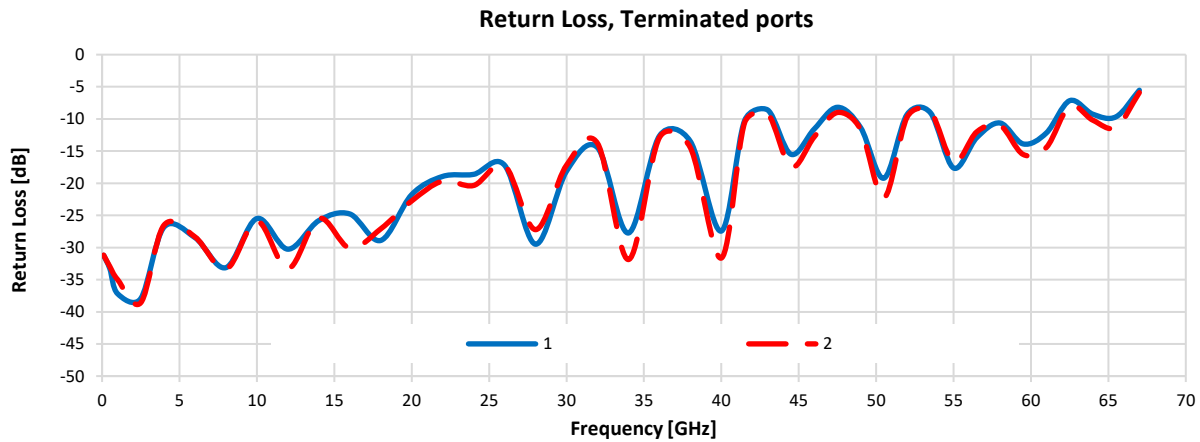
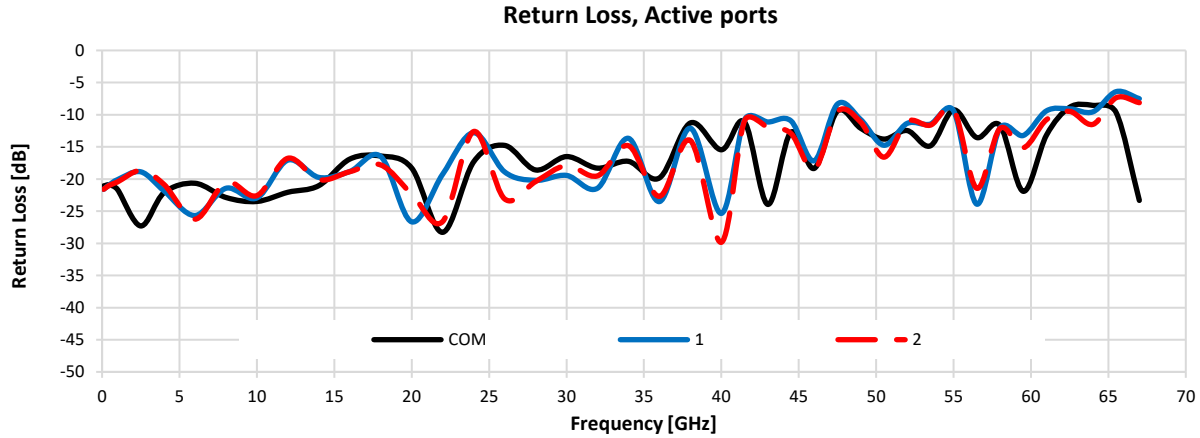

NOTES:

- A. Performance and quality attributes and conditions not expressly stated in this specification document are intended to be excluded and do not form a part of this specification document.
- B. Electrical specifications and performance data contained in this specification document are based on Mini-Circuits' applicable established test performance criteria and measurement instructions.
- C. The parts covered by this specification document are subject to Mini-Circuits standard limited warranty and terms and conditions (collectively, "Standard Terms"); Purchasers of this part are entitled to the rights and benefits contained therein. For a full statement of the Standard Terms and the exclusive rights and remedies thereunder, please visit Mini-Circuits' website at <https://www.minicircuits.com/terms/viewterm.html>



Case Style

NR

Outline Dimensions

NR3502

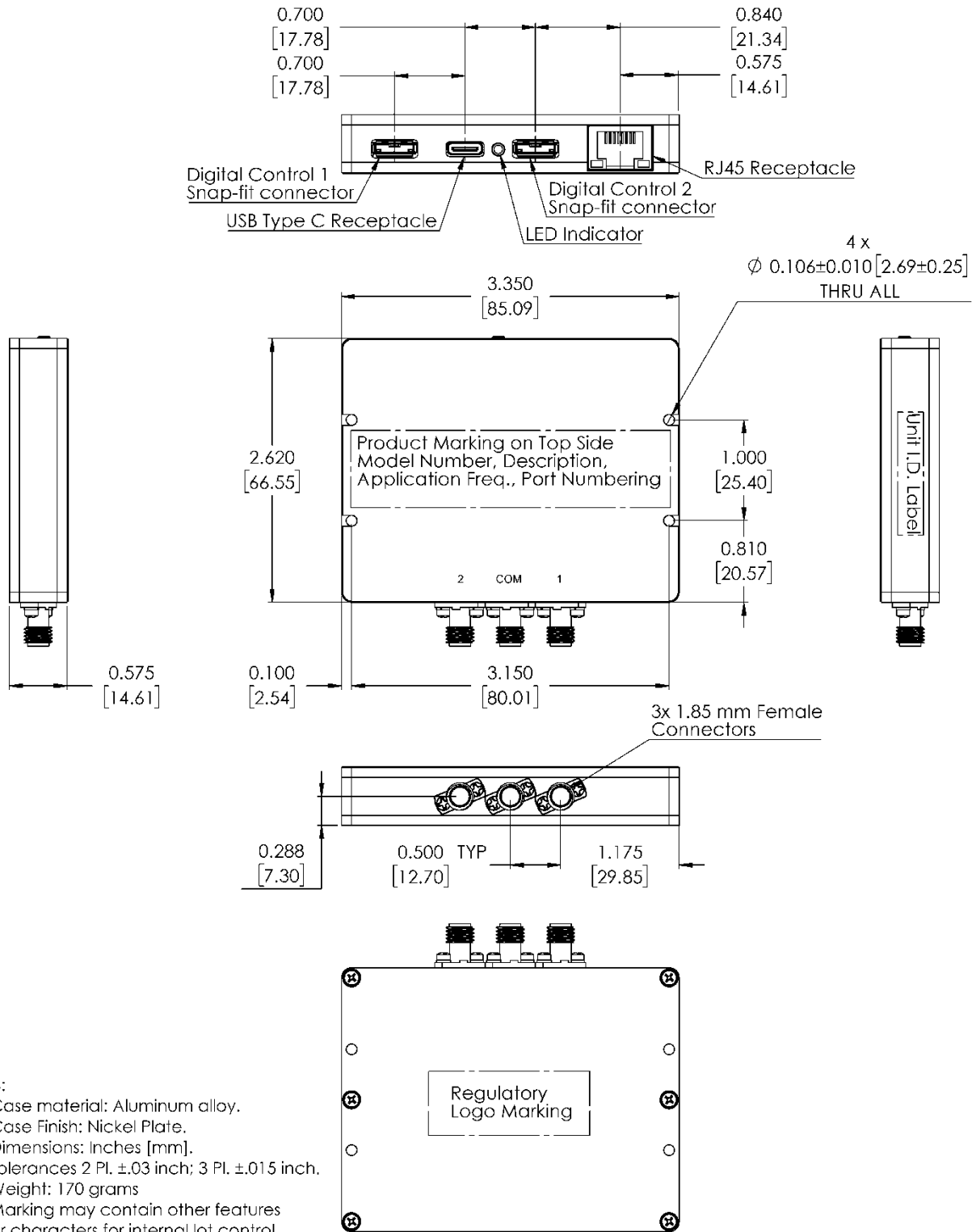

NOTES:

1. Case material: Aluminum alloy.
2. Case Finish: Nickel Plate.
3. Dimensions: Inches [mm].
Tolerances 2 Pl. ±.03 inch; 3 Pl. ±.015 inch.
4. Weight: 170 grams
5. Marking may contain other features or characters for internal lot control.

 Mini-Circuits®

www.minicircuits.com P.O. Box 350166, Brooklyn, NY 11235-0003 (718) 934-4500 sales@minicircuits.com



Environmental Specifications **ENV55**

All Mini-Circuits products are manufactured under exacting quality assurance and control standards, and are capable of meeting published specifications after being subjected to any or all of the following physical and environmental test.

Specification	Test/Inspection Condition	Reference/Spec
Operating Temperature	-0° to 50° C Ambient Environment	Individual Model Data Sheet
Storage Temperature	-20° to 60° C Ambient Environment	Individual Model Data Sheet
Operating and Storage Humidity	5% to 85% RH (non-condensing)	Ambient
Bench Handling Test	Bench Top Tip 45° & Drop	MIL-PRF-28800F
Transit Drop Test	Free Fall Drop, 20 cm (7.9 inches)	MIL-PRF-28800F Class 3