



USB & ETHERNET CONTROLLED

RF SP4T Switch Matrix RCM-3SP4T-18

50Ω DC to 18 GHz SMA Female

THE BIG DEAL

- 3 x mechanical SP4T absorptive switches
- Ethernet & USB control
- High isolation, 85 dB typ

APPLICATIONS

- Benchtop and rack mounted automated test systems
- 5G FR1, WiFi 6E, UWB, Bluetooth
- Military radio, radar & electronic warfare
- Test & measurement systems
- Fail-safe / redundancy switching

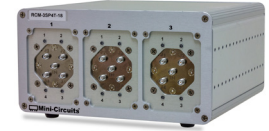

CASE STYLE: UV2068

DOWNLOAD

SOFTWARE PACKAGE

Refer to our website for compliance methodologies and qualifications



PRODUCT OVERVIEW

Mini-Circuits' RCM-3SP4T-18 comprises three independently controlled, electro-mechanical SP4T switches. Each switch operates over a wide bandwidth, from DC to 18 GHz with high isolation (85 dB typical), low insertion loss (0.2 dB typical) and high input power rating. The switches are of a fail-safe and break-before-make-configuration, with a life time of 10 million switching cycles when used within the noted specifications.

The switch box is constructed in a compact, rugged metal case (8.25 x 8.25 x 4.25") with all SMA (f) RF connectors on the front panel. The switches are controlled via USB or Ethernet, allowing control directly from a PC, or remotely over a network. Full software support is provided, including our user-friendly GUI application for Windows and a full API with programming instructions for Windows and Linux environments (both 32-bit and 64-bit systems).

KEY FEATURES

Feature	Advantages
Mechanical switches	Mechanical absorptive switches provide high reliability, repeatable performance and internal termination of input signals on the disconnected paths
Fail-safe design	The switches revert to a known default state when the DC supply is removed, allowing their use in systems that must continue to operate safely in the event of power failure
Break-before-make configuration	Prevents a momentary connection of the old and new signal paths, reducing the inconsistent transient effects that could otherwise be observed during switching
USB & Ethernet control	USB HID and Ethernet (HTTP / Telnet) interfaces provide easy compatibility with a wide range of software setups and programming environments
Full software support	User friendly Windows GUI (graphical user interface) allows manual control straight out of the box, while the comprehensive API (application programming interface) with examples and instructions allows easy automation in most programming environments

REV. A
ECO-016241
RCM-3SP4T
MCL NY
221221





USB & ETHERNET CONTROLLED

RF SP4T Switch Matrix RCM-3SP4T-18

Mini-Circuits

50Ω DC to 18 GHz SMA Female

ELECTRICAL SPECIFICATIONS AT 25°C

Parameter	Conditions (GHz)	Min.	Typ.	Max.	Units
Frequency Range		DC		18	GHz
Insertion Loss	DC - 8		0.15	0.3	dB
	8 - 12		0.25	0.4	
	12 - 18		0.5	0.8	
Isolation	DC - 8	80	100		dB
	8 - 12	75	95		
	12 - 18	60	80		
Return Loss ³	DC - 8		20		dB
	8 - 12		20		
	12 - 18		17		
Switching Time			25		ms
RF Input Power ¹	Cold switching			20	W
Switch Lifetime	100 mW hot switching ²	10			million cycles
	1W hot switching		1		
Rated Voltage	24V _{DC} input	23	24	25	V
	USB port		5		DC

1. Maximum power for any connected through path as stated; maximum power into any internal termination is 1W per port

2. Hot switching power above this level will degrade the switch lifetime

3. Ports 1-4 all states; Com in connected states only

ABSOLUTE MAXIMUM RATINGS

Parameters	Ratings
Operating Temperature	0°C to 40°C
Storage Temperature	-15°C to 85°C
Supply Voltage	26V





USB & ETHERNET CONTROLLED

RF SP4T Switch Matrix RCM-3SP4T-18

50Ω DC to 18 GHz SMA Female

SWITCHING STATES (PER SWITCH)

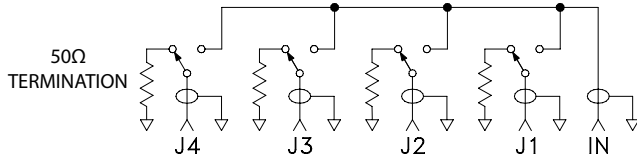

CONNECTIONS

Port Name	Connector Type
RF Switch 1 (In & 1-4)	SMA female
RF Switch 2 (In & 1-4)	SMA female
RF Switch 3 (In & 1-4)	SMA female
USB	USB type-B
Ethernet / LAN	RJ45
24V DC Input	2.1mm center positive DC socket

OUTLINE DRAWING

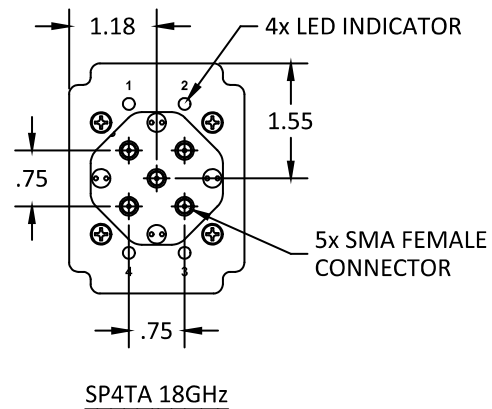
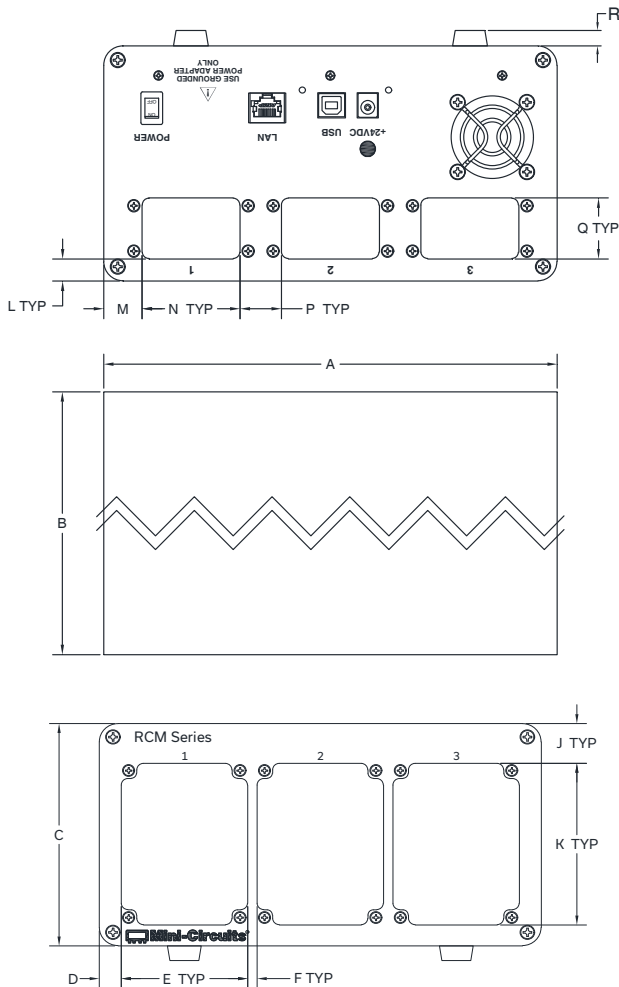

OUTLINE DIMENSIONS (Inches mm)

A	B	C	D	E	F	J	K	L	M	N	P	Q	R	wt
8.25	8.25	4.25	.41	2.36	.18	.76	3.09	.40	.70	1.78	.76	1.10	.28	grms
209.55	209.55	107.95	10.41	59.94	4.57	19.30	78.49	10.16	17.78	45.21	19.30	27.94	7.1	2350





USB & ETHERNET CONTROLLED

RF SP4T Switch Matrix RCM-3SP4T-18

50Ω DC to 18 GHz SMA Female

TYPICAL PERFORMANCE CURVES

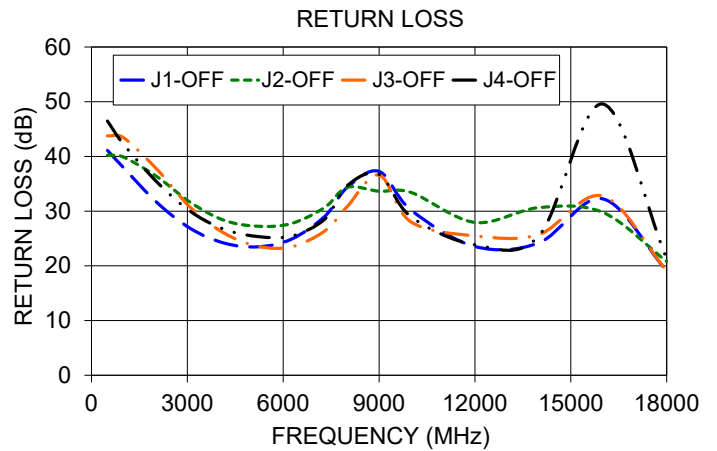
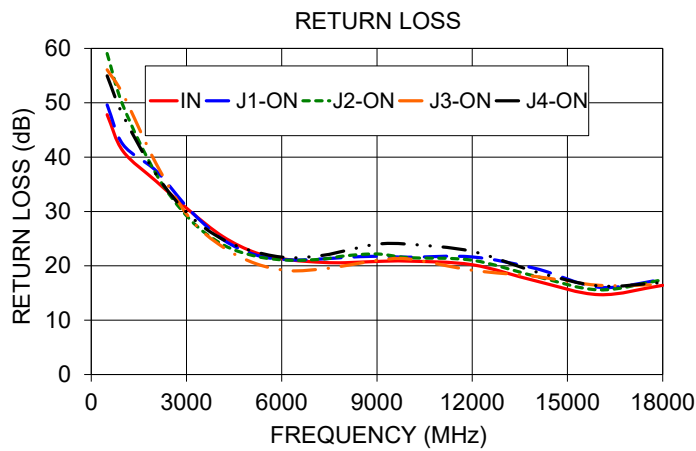
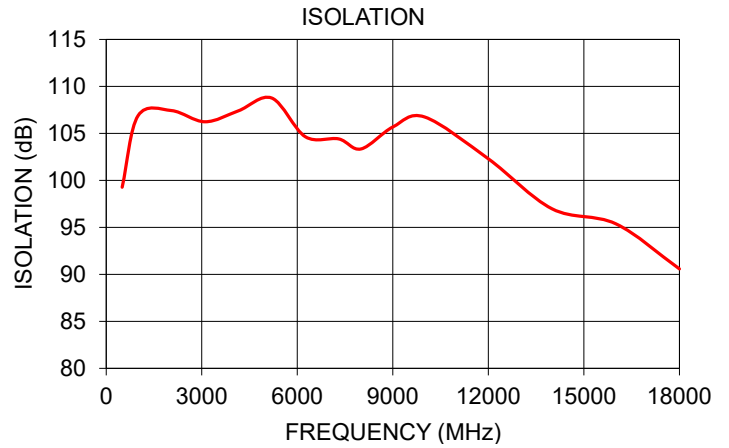
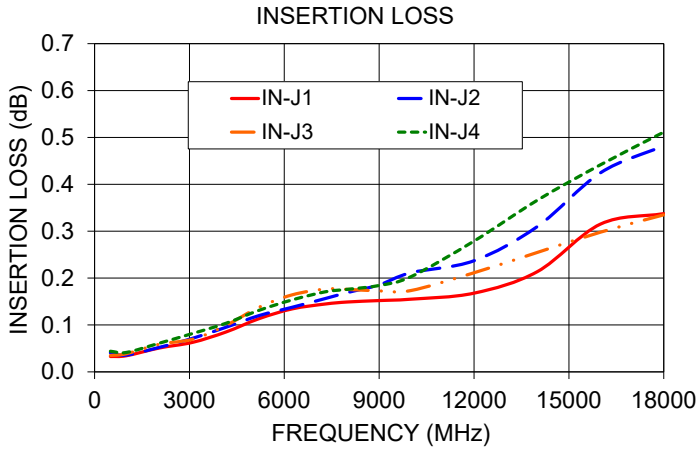



SOFTWARE SPECIFICATIONS

SOFTWARE & DOCUMENTATION DOWNLOAD:

- Mini-Circuits' full software and support package including user guide, Windows GUI, DLL files, programming manual and examples can be downloaded free of charge from: https://www.minicircuits.com/softwaredownload/ztm_rcm.html
- Please contact testsolutions@minicircuits.com for support

MINIMUM SYSTEM REQUIREMENTS:

Parameter	Requirements	
Interface	USB HID & Ethernet (HTTP & Telnet)	
System Requirements	GUI	Windows 7 or later
	USB API DLL	Windows 7 or later and programming environment with ActiveX or .NET support
	USB Direct Programming	Linux, Windows 7 or later
	Ethernet	Windows, Linux or Mac computer with a network port and Ethernet TCP/IP support
Hardware	Intel i3 or equivalent	

APPLICATION PROGRAMMING INTERFACE (API)

ETHERNET SUPPORT:

- Simple ASCII / SCPI command set for attenuator control
- Communication via HTTP or Telnet
- Supported by most common programming environment

USB SUPPORT (WINDOWS):

- ActiveX COM DLL file for creation of 32-bit programs
- .NET library DLL file for creation of 32 / 64-bit programs
- Supported by most common programming environments (refer to application note AN-49-001 for summary of supported environments)

USB SUPPORT (LINUX):

- Direct USB programming using a series of USB interrupt codes

Full programming instructions and examples available for a wide range of programming environments / languages.



USB & ETHERNET CONTROLLED

RF SP4T Switch Matrix RCM-3SP4T-18

50Ω DC to 18 GHz SMA Female

GRAPHICAL USER INTERFACE (GUI) FOR WINDOWS - KEY FEATURES

- Connect via USB or Ethernet
- Run GUI in "demo mode" to evaluate software without a hardware connection

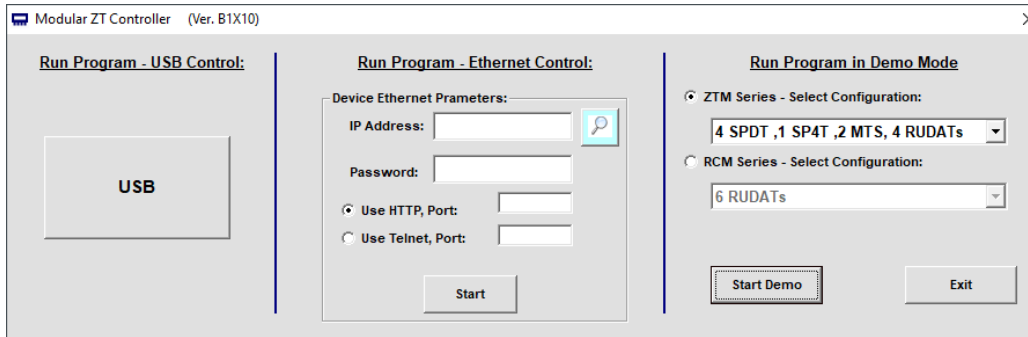

- View and set switch states at the click of a button
- Configure and run timed switching sequences
- Set start-up switch state
- Configure Ethernet IP settings

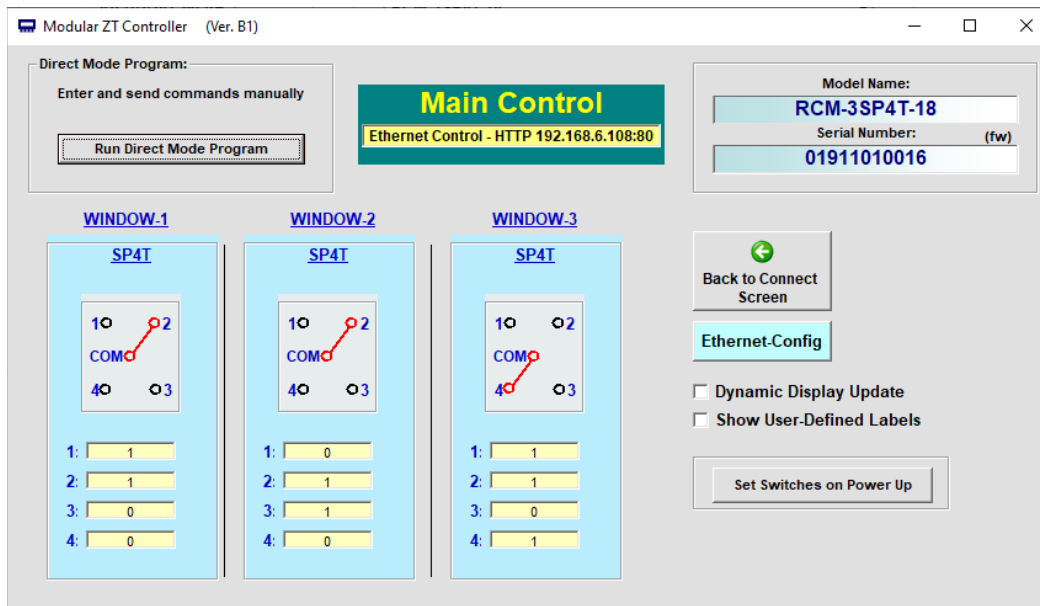



USB & ETHERNET CONTROLLED

RF SP4T Switch Matrix **RCM-3SP4T-18**

Mini-Circuits

50Ω DC to 18 GHz SMA Female

ORDERING INFORMATION

Refer to Mini-Circuits' website for pricing and availability information:

<https://www.minicircuits.com/WebStore/dashboard.html?model=RCM-3SP4T-18>

Model	Description
RCM-3SP4T-18	USB & Ethernet controlled transfer switch matrix

Included Accessories	Part No.	Description
	AC/DC-24-3W1	AC/DC 24V _{DC} Grounded Power Adaptor. Operating temperature: 0°C to +40°C, I _{Max} =2.5A
See Below	CBL-3W1-XX	AC Power Cord (Select one power cord from below with each Switch Matrix box)
	USB-CBL-AB-3+	2.7 ft (0.8 m) USB Cable: USB type A(Male) to USB type B(Male)

AC Power Cords ⁵	Part No.	Description
	CBL-3W1-US	Power Cord for United States
	CBL-3W1-EU	Power Cord for Europe
	CBL-3W1-UK	Power Cord for United Kingdom
	CBL-3W1-AU	Power Cord for Australia and China
	CBL-3W1-IL	Power Cord for Israel

⁵ If you need a Power cord for a country not listed please contact testsolutions@minicircuits.com

OPTIONAL ACCESSORIES

USB-CBL-AB-3+	2.7 ft (0.8 m) USB Cable: USB type A(Male) to USB type B(Male)
USB-CBL-AB-7+	6.8 ft (2.1 m) USB Cable: USB type A(Male) to USB type B(Male)
USB-CBL-AB-11+	11 ft (3.4 m) USB Cable: USB type A(Male) to USB type B(Male)
CBL-RJ45-MM-5+	5 ft (1.5 m) Ethernet cable: RJ45(Male) to RJ45(Male) Cat 5E cable

- NOTES**
- Performance and quality attributes and conditions not expressly stated in this specification document are intended to be excluded and do not form a part of this specification document.
 - Electrical specifications and performance data contained in this specification document are based on Mini-Circuit's applicable established test performance criteria and measurement instructions.
 - The parts covered by this specification document are subject to Mini-Circuits standard limited warranty and terms and conditions (collectively, "Standard Terms"); Purchasers of this part are entitled to the rights and benefits contained therein. For a full statement of the standard. Terms and the exclusive rights and remedies thereunder, please visit Mini-Circuits' website at www.minicircuits.com/MCLStore/terms.jsp



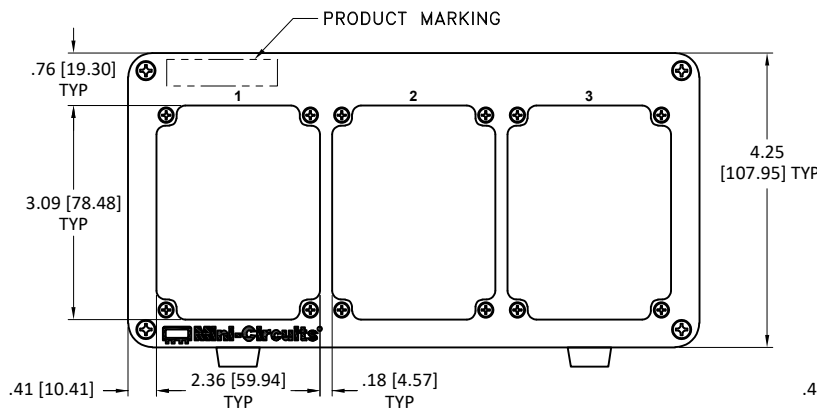
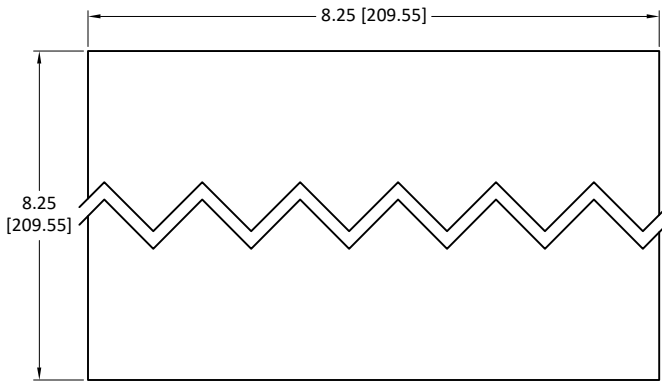
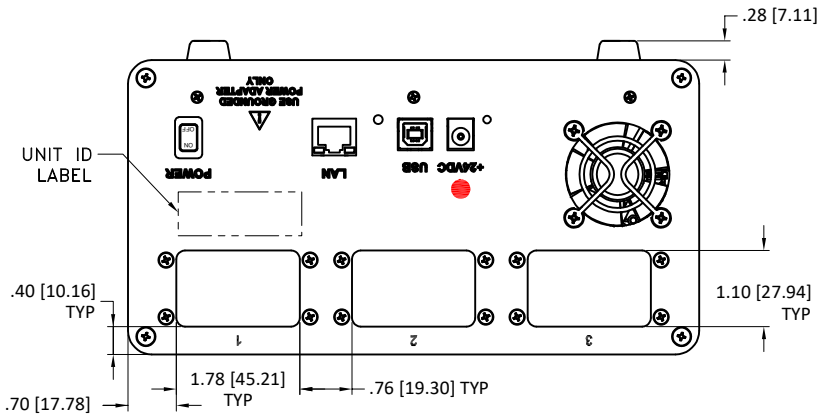

FRONT PANEL FOR RCM WITH RUDAT, SPDT, SP4T, SP6T & MTS SWITCHES

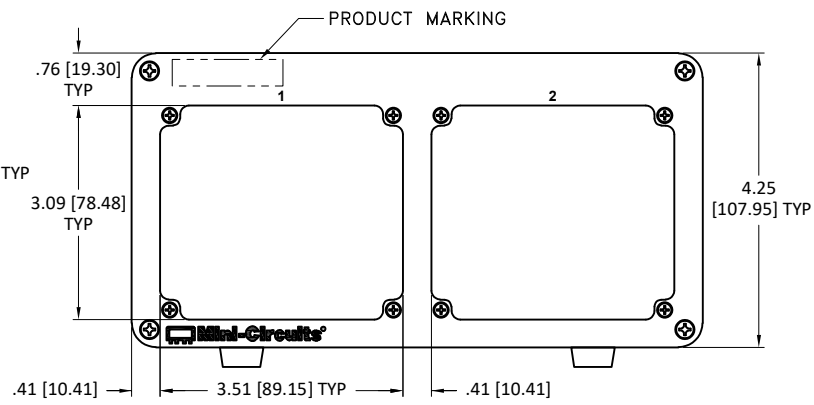

FRONT PANEL FOR RCM WITH SP8T SWITCHES

Notes:

1. Case material: Aluminum alloy.
2. Finish: Clear chemical conversion coating
3. Dimensions are in inches [mm]. Tolerances: 2 Pl. $\pm .03$ inch; 3 Pl. $\pm .015$ inch
4. Weight: 2350 grams.
5. Marking may contain other features or characters for internal lot control.



P.O. Box 350166, Brooklyn, New York 11235-0003 (718) 934-4500 Fax (718) 332-4661 For detailed performance specs & shopping online see Mini-Circuits web site



The Design Engineers Search Engine Provides ACTUAL Data Instantly From MINI-CIRCUITS At: www.minicircuits.com

RF/IF MICROWAVE COMPONENTS

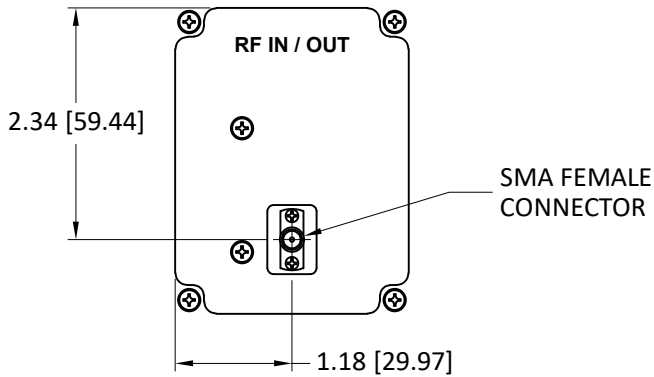

FRONT PANEL

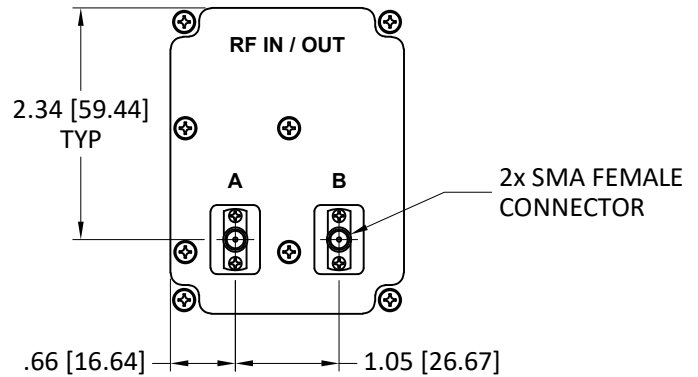

FRONT PANEL

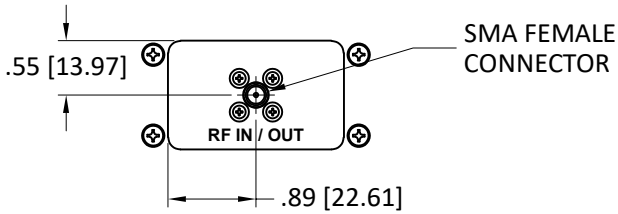

REAR PANEL

SINGLE RUDAT

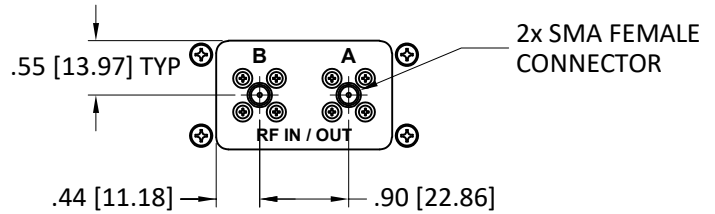

REAR PANEL

DUAL RUDAT

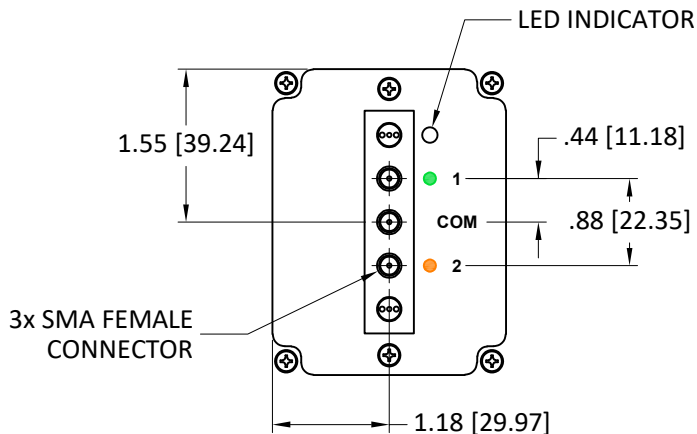

SPDTA 18GHz
SPDTA 26GHz

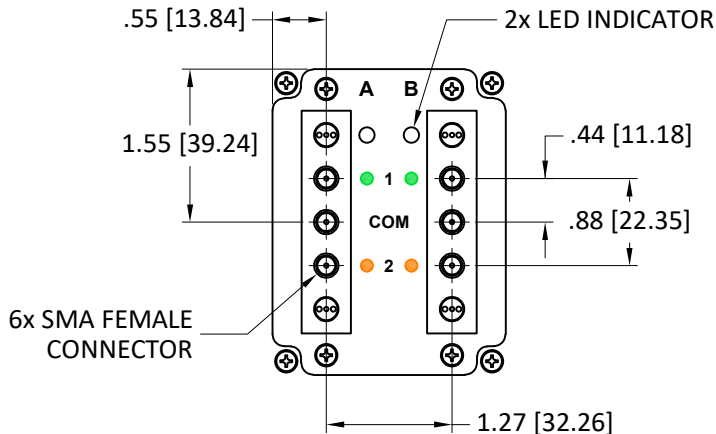

DUAL SPDTA 18GHz
DUAL SPDTA 26GHz

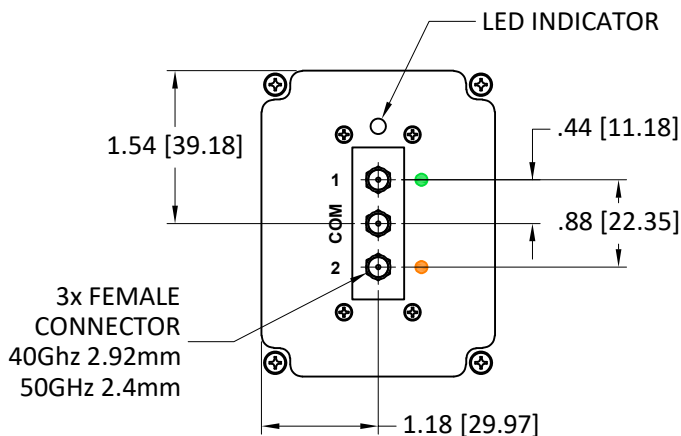

SPDT 40GHz
SPDT 50GHz

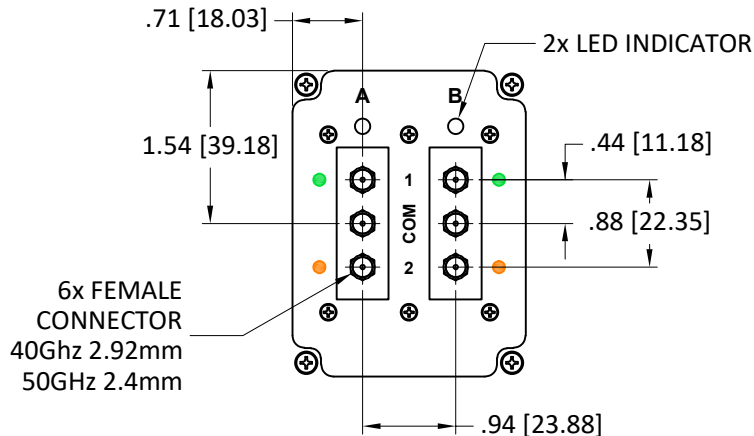

DUAL SPDT 40GHz
DUAL SPDT 50GHz

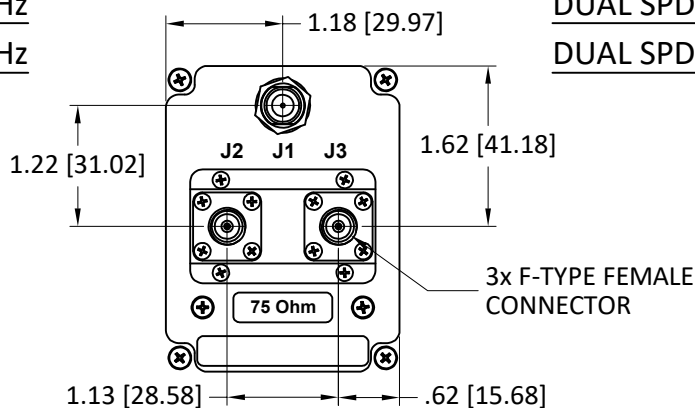

SPDT 2.15GHz

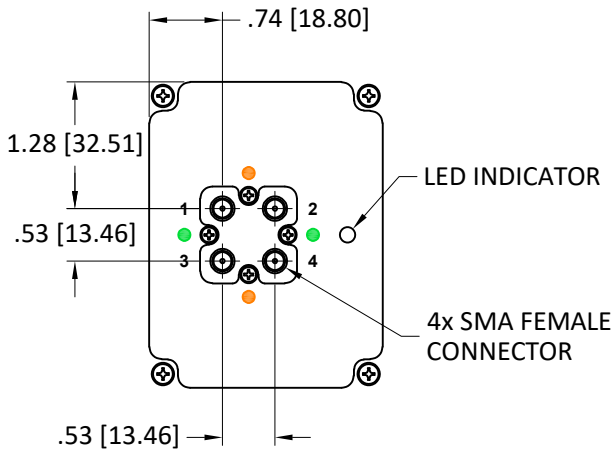

MTS 18GHz

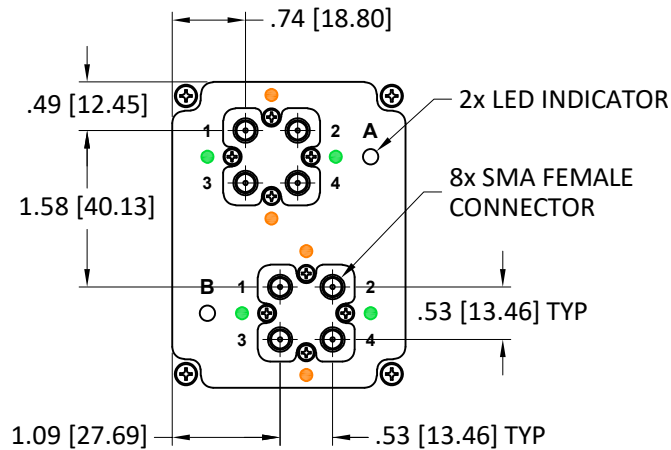

DUAL MTS 18GHz

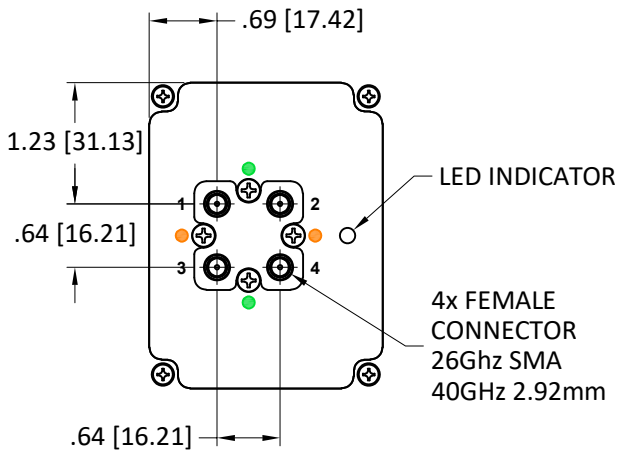

MTS 26GHz
MTS 40GHz

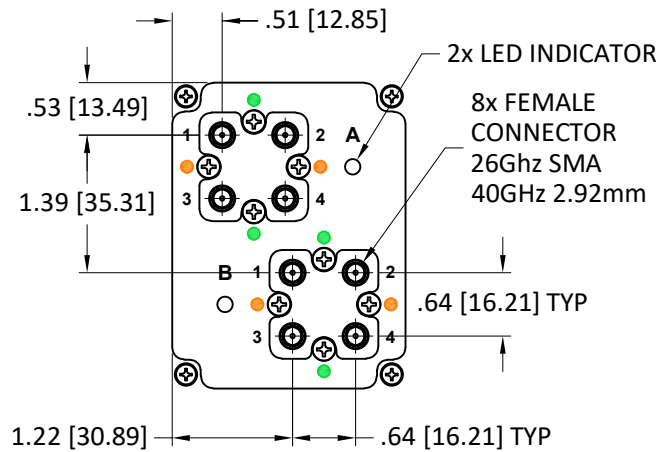

DUAL MTS 26GHz
DUAL MTS 40GHz

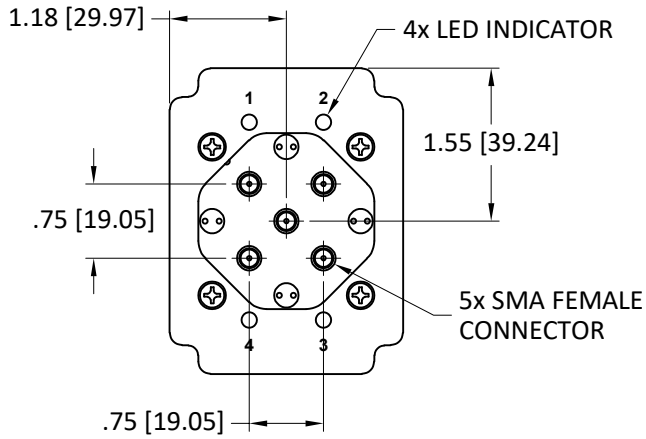

SP4TA 18GHz

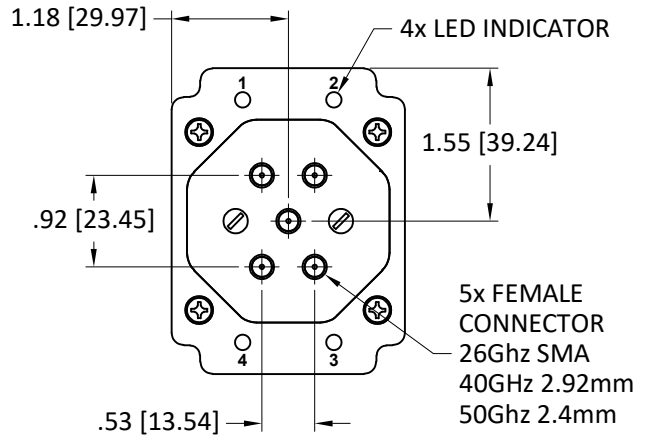

SP4TA 26GHz
SP4TA 40GHz
SP4TA 50GHz

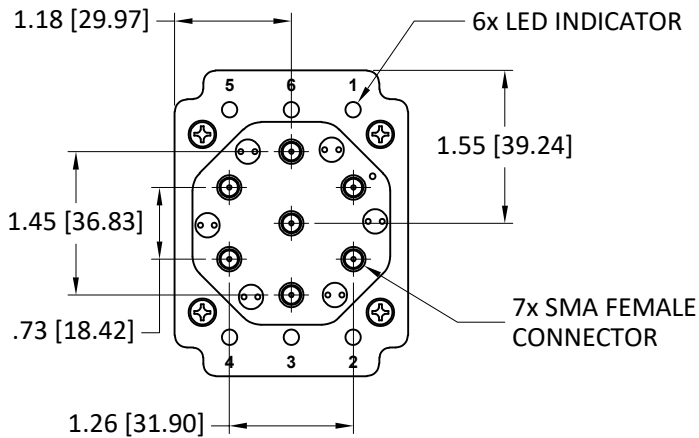

SP6TA 12GHz
SP6TA 18GHz

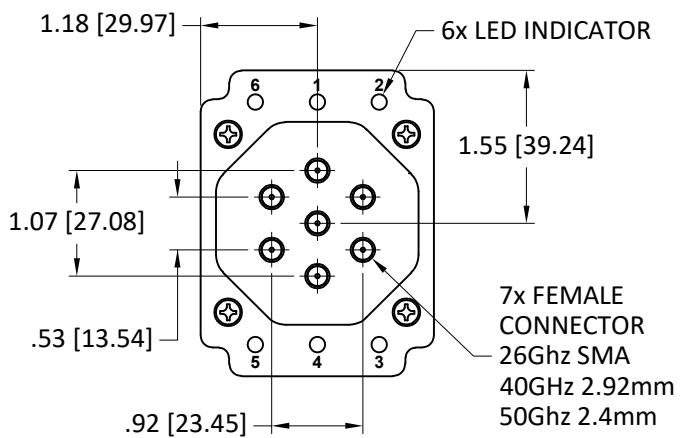

SP6TA 26GHz
SP6TA 40GHz
SP6TA 50GHz

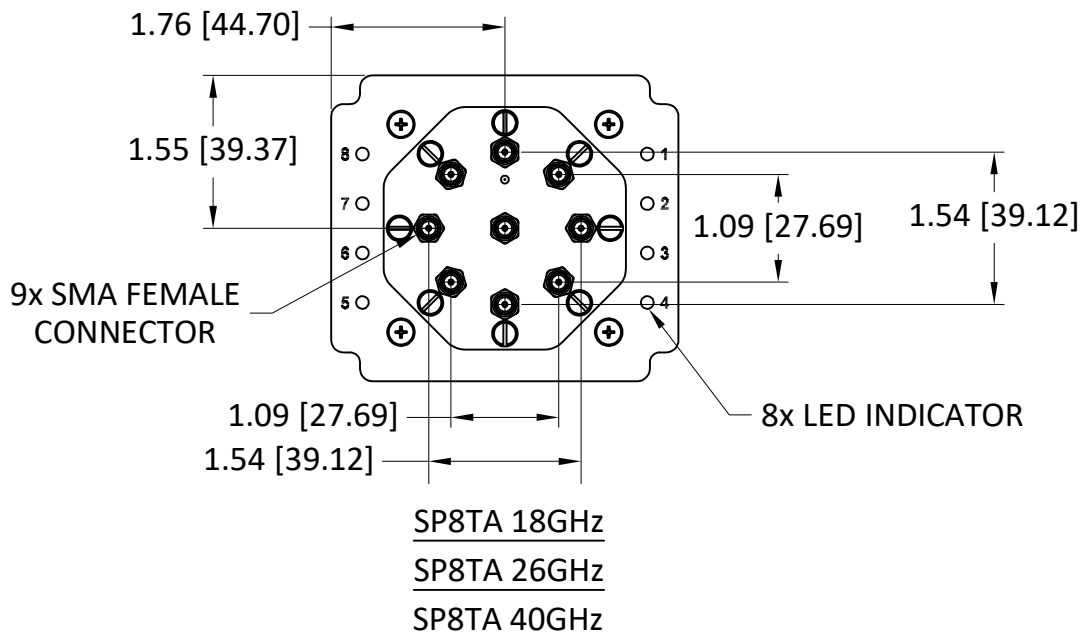
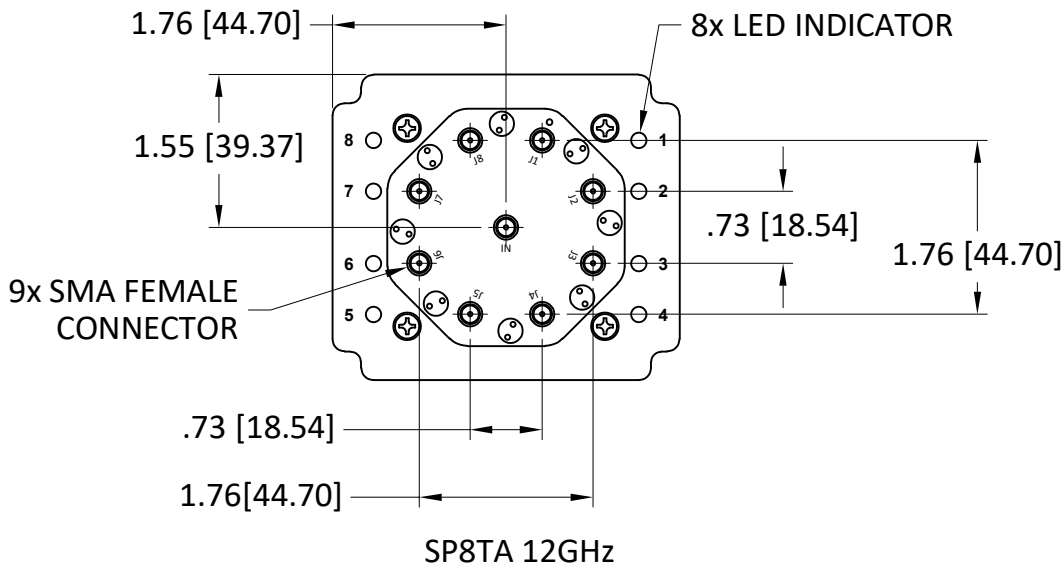

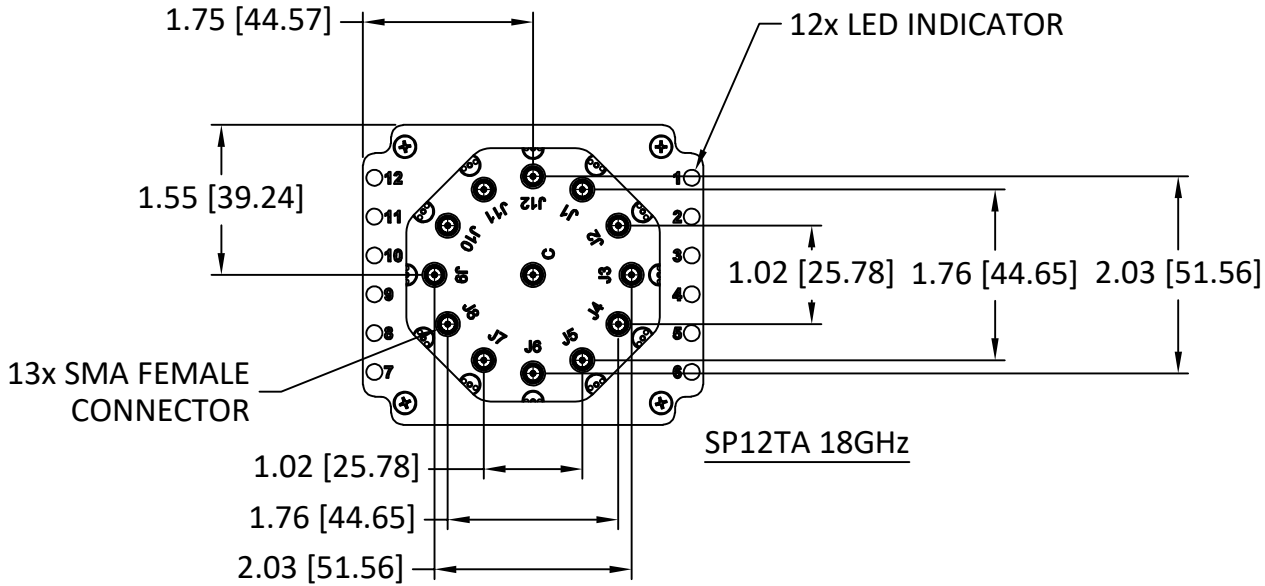



Environmental Specifications **ENV55**

All Mini-Circuits products are manufactured under exacting quality assurance and control standards, and are capable of meeting published specifications after being subjected to any or all of the following physical and environmental test.

Specification	Test/Inspection Condition	Reference/Spec
Operating Temperature	-0° to 50° C Ambient Environment	Individual Model Data Sheet
Storage Temperature	-20° to 60° C Ambient Environment	Individual Model Data Sheet
Operating and Storage Humidity	5% to 85% RH (non-condensing)	Ambient
Bench Handling Test	Bench Top Tip 45° & Drop	MIL-PRF-28800F
Transit Drop Test	Free Fall Drop, 20 cm (7.9 inches)	MIL-PRF-28800F Class 3