



USB & ETHERNET CONTROLLED

# RF SP8T Switch Matrix RCM-1SP8T-26

50Ω DC to 26.5 GHz

## THE BIG DEAL

- Mechanical SP8T switch
- Excellent performance to 26.5 GHz
- High reliability, 2 million switch cycles
- 5W power rating (cold switching)

## APPLICATIONS

- 5G node / device testing
- Automated test equipment
- Fail-safe / redundancy switching



CASE STYLE: UV2068

DOWNLOAD

SOFTWARE PACKAGE

**RoHS Compliant**

See our website for RoHS Compliance methodologies and qualifications

## PRODUCT OVERVIEW

Mini-Circuits' RCM-1SP8T-26 is a software controlled, electro-mechanical SP8T switch. It operates over an extremely wide bandwidth, from DC to 26.5 GHz with high isolation and low insertion loss. The absorptive switch is of a failsafe and break-before-make-configuration, with a minimum lifetime of 2 million switching cycles per switch position, when used within the noted specifications.

The switch box is constructed in a compact, rugged metal case (8.25 x 8.25 x 4.25") with all SMA (f) RF connectors on the front panel. The switches are controlled via USB or Ethernet, allowing control directly from a PC, or remotely over a network. Full software support is provided, including our user-friendly GUI application for Windows and a full API with programming instructions for Windows and Linux environments (both 32-bit and 64-bit systems).

## KEY FEATURES

Feature	Advantages
Mechanical SP8T switch	Mechanical absorptive switches provide high reliability, repeatable high performance and internal terminations of input signals on the disconnected paths
Operation from DC to 26.5 GHz	Supports a wide range of RF test and signal routing applications, including 2G, 3G, 4G, 5G, C / S / X / Ku bands with a single device.
Break-before-make configuration	Prevents a momentary connection of the old and new signal paths, reducing the inconsistent transient effects that could otherwise be observed during switching
USB & Ethernet control	USB HID and Ethernet (HTTP / Telnet) interfaces provide easy compatibility with a wide range of software setups and programming environments
Full software support	User friendly Windows GUI (graphical user interface) allows manual control straight out of the box, while the comprehensive API (application programming interface) with examples and instructions allows easy automation in most programming environments

REV. B  
ECO-024239  
RCM-1SP8T-26  
MCL NY  
250129





## ELECTRICAL SPECIFICATIONS AT 25°C

Parameter	Conditions (GHz)	Min.	Typ.	Max.	Units
Frequency Range		DC		26.5	GHz
Insertion Loss	DC - 8	—	0.15	0.30	dB
	8 - 18	—	0.30	0.60	
	18 - 26.5	—	0.80	1.10	
Isolation	DC - 26.5	55	70	—	dB
VSWR	DC - 6	—	1.20	—	:1
	6 - 18	—	1.35	—	
	18 - 26.5	—	1.50	—	
Switching Time	—	—	25	—	ms
RF Input Power (Cold Switching) <sup>1</sup>	DC - 8	—	—	20	W
	8 - 18	—	—	10	
	18 - 26.5	—	—	5	
Switch Lifetime (per Switch)	100 mW hot switching <sup>2</sup>	2	—	—	million cycles
	1W hot switching	—	1	—	
Rated Voltage	24V <sub>DC</sub> input	23	24	25	V
	USB port	—	5	—	

1. Maximum power for any connected through path as stated; maximum power into any internal termination is 1W per port.  
 2. Hot switching powers above this level will degrade the switch lifetime.

## MAXIMUM RATINGS

Parameters	Ratings
Operating Temperature	0°C to 40°C
Storage Temperature	-15°C to 85°C
Supply Voltage	26V



USB & ETHERNET CONTROLLED

# RF SP8T Switch Matrix RCM-1SP8T-26

## SWITCHING CONFIGURATION:

- Normally open (all port disconnected)
- Absorptive (internal terminations on ports J1-J8)

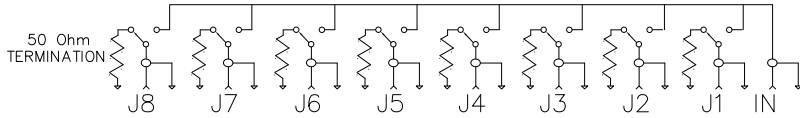

## CONNECTIONS

Port Name	Connector Type
RF Switch A (Com & 1-8)	SMA female
USB	USB type-B
Ethernet / LAN	RJ45
24V <sub>DC</sub> Input	2.1mm center positive DC socket

## OUTLINE DRAWING (UV2068)

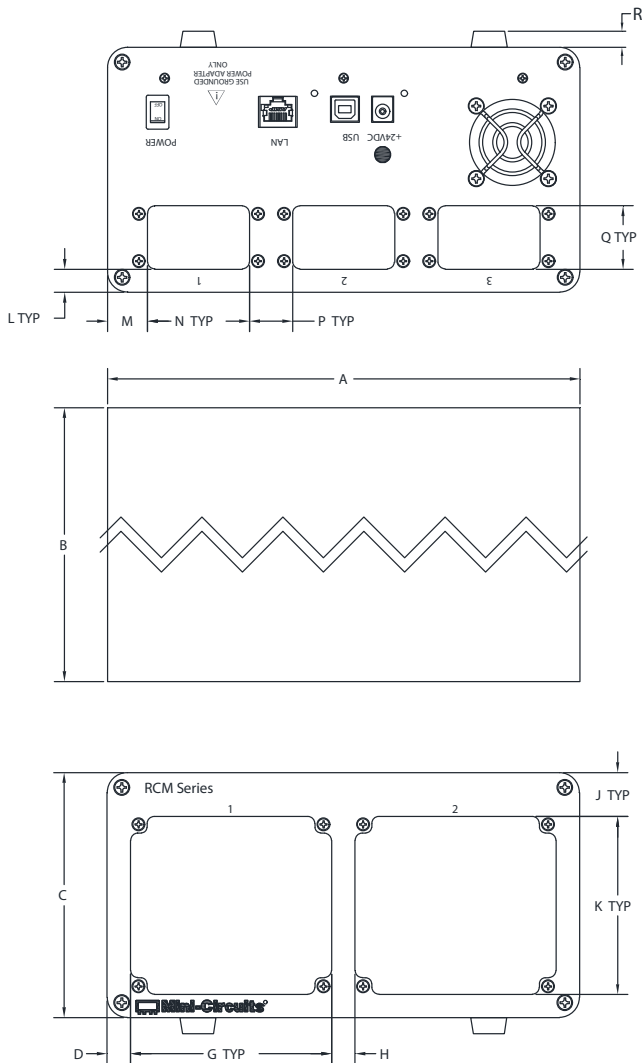

FRONT PANEL FOR RCM WITH SP8T SWITCHES

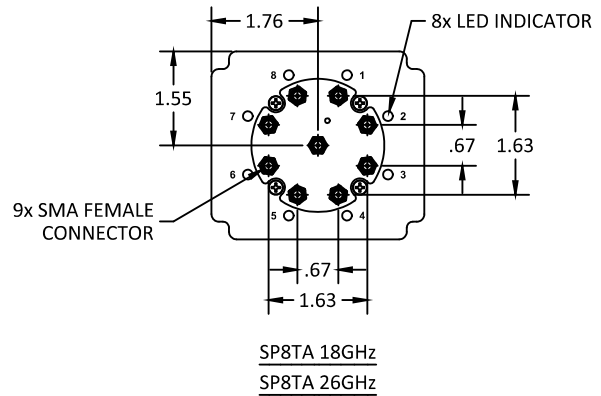
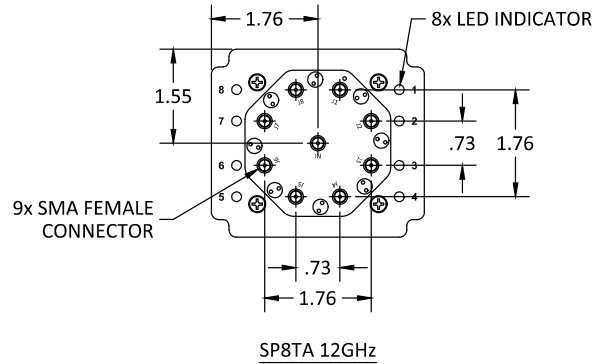

## OUTLINE DIMENSIONS (Inches / mm)

A	B	C	D	E	F	J	K	L	M	N	P	Q	R	wt
8.25	8.25	4.25	.41	2.36	.18	.76	3.09	.40	.70	1.78	.76	1.10	.28	grms
209.55	209.55	107.95	10.41	59.94	4.57	19.30	78.49	10.16	17.78	45.21	19.30	27.94	7.1	2350





## TYPICAL PERFORMANCE DATA (PER SWITCH)

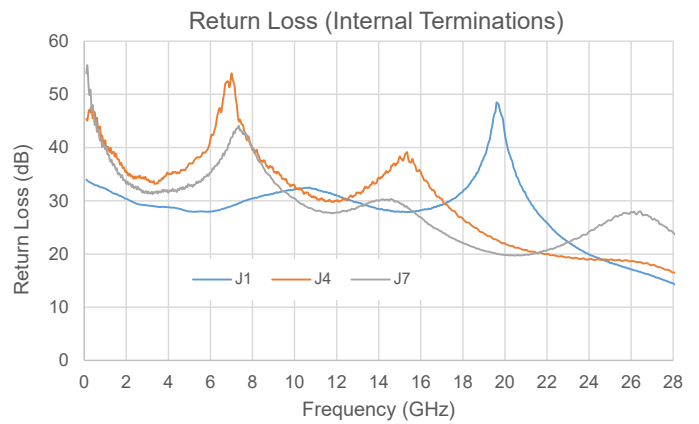
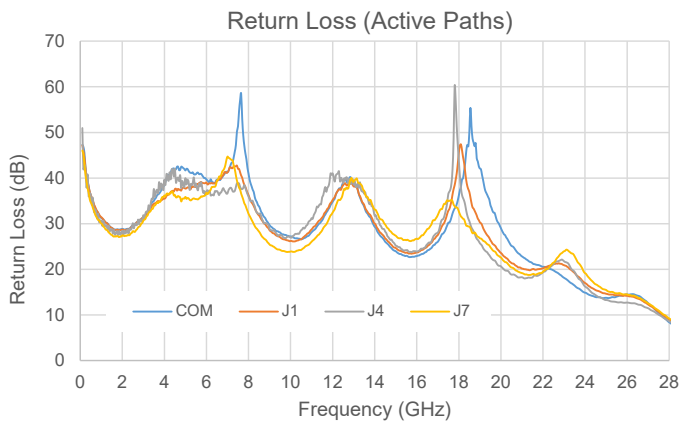
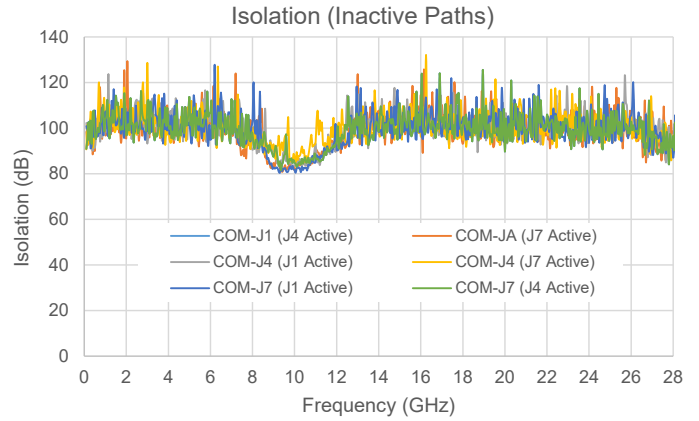
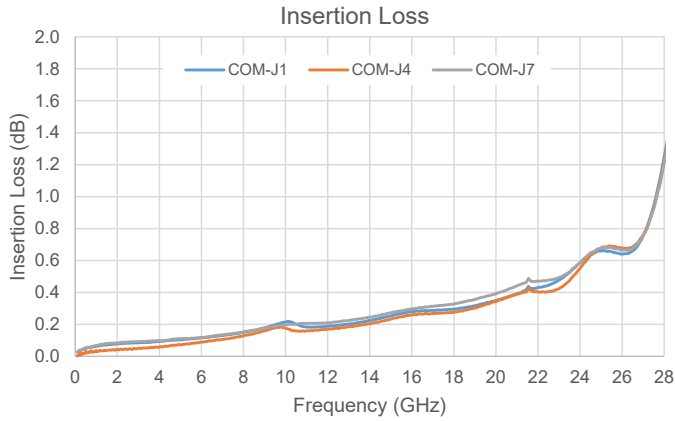



## SOFTWARE SPECIFICATIONS

### SOFTWARE & DOCUMENTATION DOWNLOAD:

- Mini-Circuits' full software and support package including user guide, Windows GUI, DLL files, programming manual and examples can be downloaded free of charge from: [www.minicircuits.com/softwaredownload/rfswitchcontroller.html](http://www.minicircuits.com/softwaredownload/rfswitchcontroller.html)
- Please contact [testsolutions@minicircuits.com](mailto:testsolutions@minicircuits.com) for support

### MINIMUM SYSTEM REQUIREMENTS:

Parameter	Requirements	
Interface	USB HID & Ethernet (HTTP & Telnet)	
System Requirements	GUI	Windows 98 or later
	USB API DLL	Windows 98 or later and programming environment with ActiveX or .NET support
	USB Direct Programming	Linux, Windows 98 or later
	Ethernet	Windows, Linux or Mac computer with a network port and Ethernet TCP/IP support
Hardware	Pentium II or later with 256 MB RAM	

## APPLICATION PROGRAMMING INTERFACE (API)

### ETHERNET SUPPORT:

- Simple ASCII / SCPI command set for attenuator control
- Communication via HTTP or Telnet
- Supported by most common programming environments

### USB SUPPORT (WINDOWS):

- ActiveX COM DLL file for creation of 32-bit programs
- .NET library DLL file for creation of 32 / 64-bit programs
- Supported by most common programming environments (refer to application note AN-49-001 for summary of supported environments)

### USB SUPPORT (LINUX):

- Direct USB programming using a series of USB interrupt codes

Full programming instructions and examples available for a wide range of programming environments / languages.



### GRAPHICAL USER INTERFACE (GUI) FOR WINDOWS - KEY FEATURES

- Connect via USB or Ethernet
- Run GUI in "demo mode" to evaluate software without a hardware connection

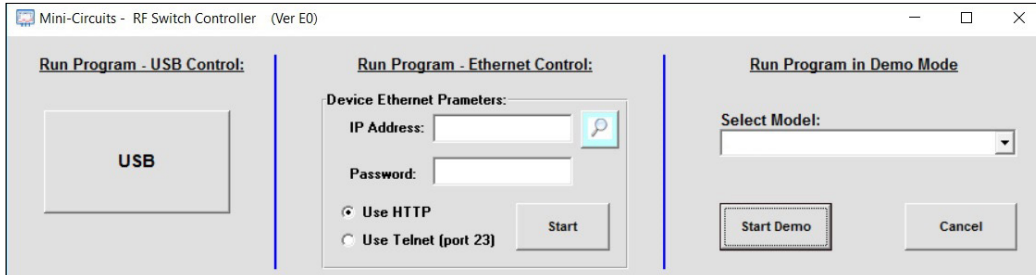

- View and set switch states at the click of a button
- Configure and run timed switching sequences
- Set start-up switch state
- Configure Ethernet IP settings

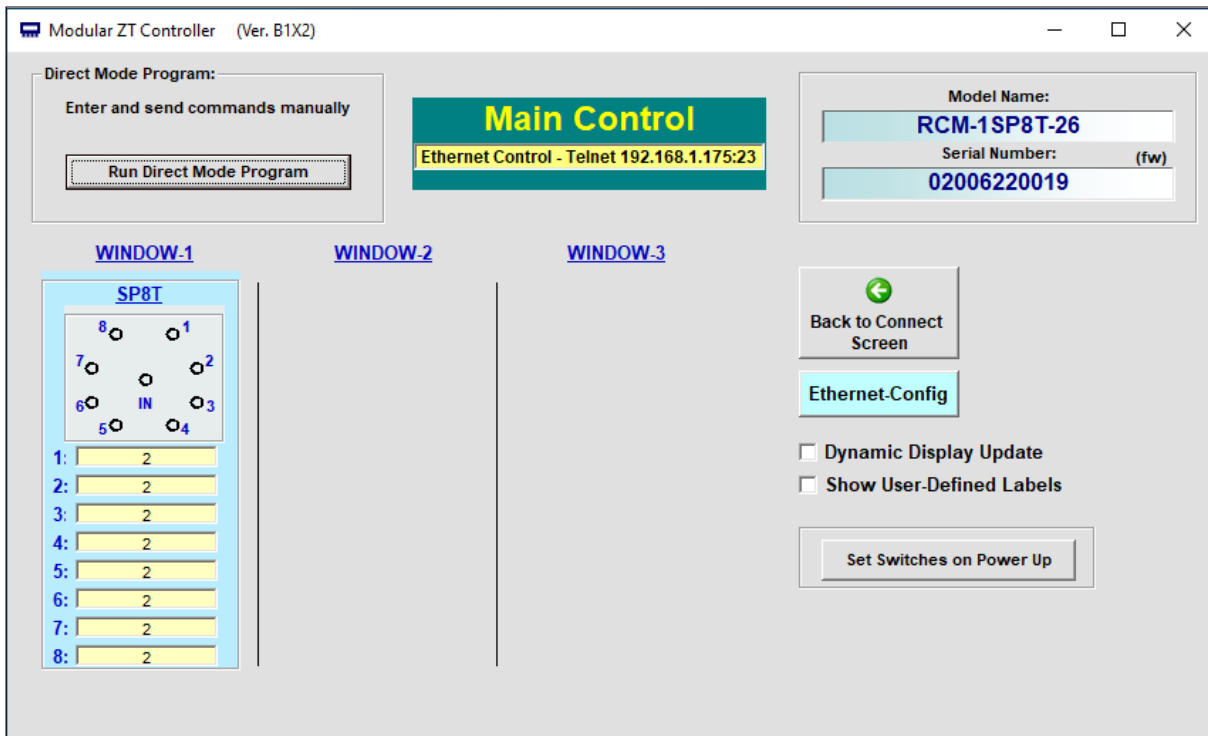









## ORDERING INFORMATION

Please contact Mini-Circuits' Test Solutions department for price and availability: [testsolutions@minicircuits.com](mailto:testsolutions@minicircuits.com)

Model	Description
RCM-1SP8T-26	USB & Ethernet controlled SP8T switch matrix

Included Accessories	Part No.	Description
	AC/DC-24-3W1	AC/DC 24V <sub>DC</sub> Grounded Power Adaptor. Operating temperature: 0°C to +40°C, I <sub>Max</sub> =2.5A
See Below	CBL-3W1-XX	AC Power Cord (Select one power cord from below with each Switch Matrix box)
	USB-CBL-AB-3+	2.7 ft (0.8 m) USB Cable: USB type A(Male) to USB type B(Male)

AC Power Cords <sup>5</sup>	Part No.	Description
	CBL-3W1-US	Power Cord for United States
	CBL-3W1-EU	Power Cord for Europe
	CBL-3W1-UK	Power Cord for United Kingdom
	CBL-3W1-AU	Power Cord for Australia and China
	CBL-3W1-IL	Power Cord for Israel

5. If you need a Power cord for a country not listed please contact [testsolutions@minicircuits.com](mailto:testsolutions@minicircuits.com)

## OPTIONAL ACCESSORIES

USB-CBL-AB-3+	2.7 ft (0.8 m) USB Cable: USB type A(Male) to USB type B(Male)
USB-CBL-AB-7+	6.8 ft (2.1 m) USB Cable: USB type A(Male) to USB type B(Male)
USB-CBL-AB-11+	11 ft (3.4 m) USB Cable: USB type A(Male) to USB type B(Male)
CBL-RJ45-MM-5+	5 ft (1.5 m) Ethernet cable: RJ45(Male) to RJ45(Male) Cat 5E cable

- NOTES**
- A. Performance and quality attributes and conditions not expressly stated in this specification document are intended to be excluded and do not form a part of this specification document.
  - B. Electrical specifications and performance data contained in this specification document are based on Mini-Circuit's applicable established test performance criteria and measurement instructions.
  - C. The parts covered by this specification document are subject to Mini-Circuits standard limited warranty and terms and conditions (collectively, "Standard Terms"); Purchasers of this part are entitled to the rights and benefits contained therein. For a full statement of the standard. Terms and the exclusive rights and remedies thereunder, please visit Mini-Circuits' website at [www.minicircuits.com/MCLStore/terms.jsp](http://www.minicircuits.com/MCLStore/terms.jsp)





# USB & Ethernet Controlled RF SP8T Switch Matrix RCM-1SP8T-26

## Typical Performance Curves

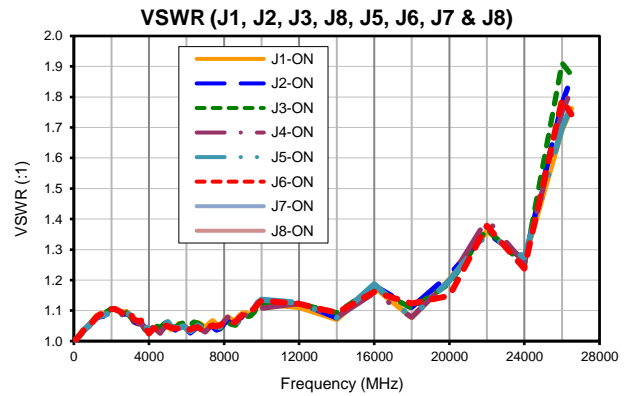
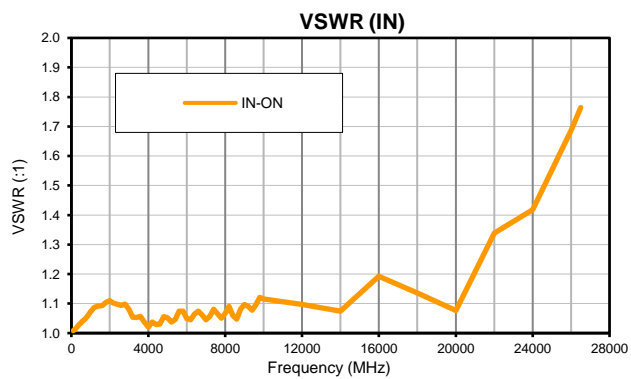
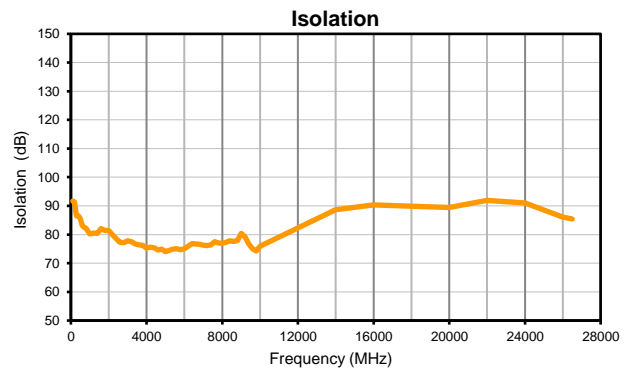
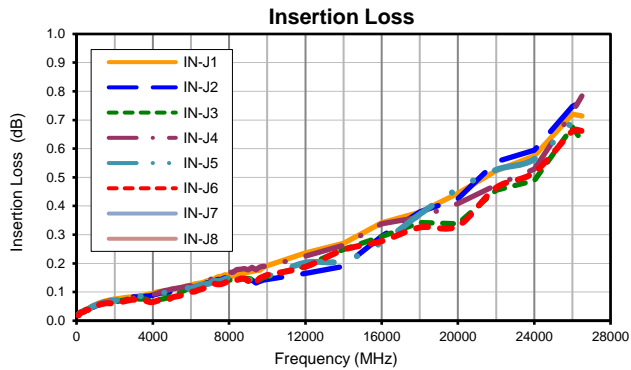

## Outline Dimensions

UV2068

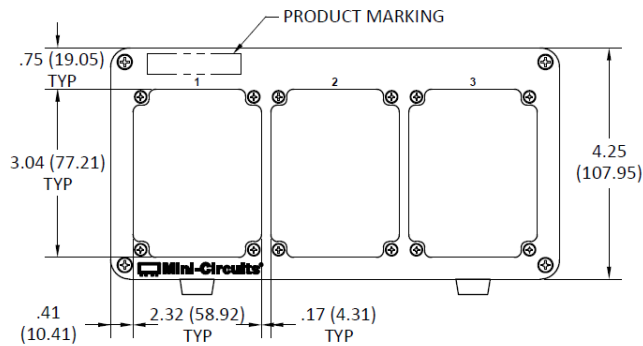
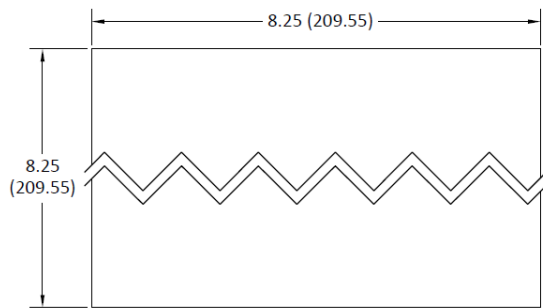
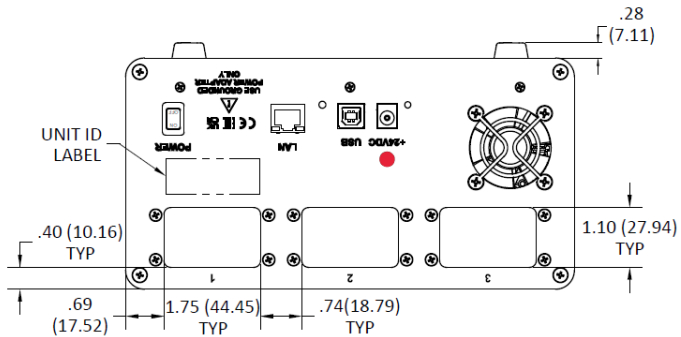

FRONT PANEL FOR RCM WITH RUDAT, SPDT, SP4T, SP6T & MTS SWITCHES

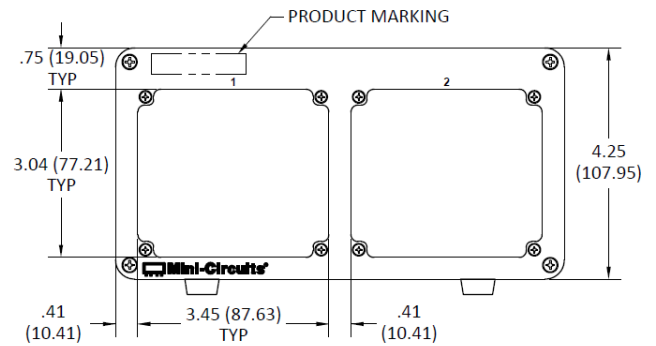

FRONT PANEL FOR RCM WITH SP8T SWITCHES

### Notes:

1. Case material: Aluminum alloy.
2. Finish: Clear chemical conversion coating
3. Dimensions are in inches (mm). Tolerances: 2 Pl.  $\pm 0.03$  inch; 3 Pl.  $\pm 0.015$  inch
4. Weight: 2350 grams.
5. Marking may contain other features or characters for internal lot control.



Distribution Centers NORTH AMERICA 800-654-7949 • 417-335-5935 • Fax 417-335-5945 • EUROPE 44-1252-832600 • Fax 44-1252-837010

Mini-Circuits ISO 9001 & ISO 14001 Certified

INTERNET <http://www.minicircuits.com>

P.O. Box 350166, Brooklyn, New York 11235-0003 (718) 934-4500 Fax (718) 332-4661

## RUDAT Programmable Attenuator Options:

UV2068

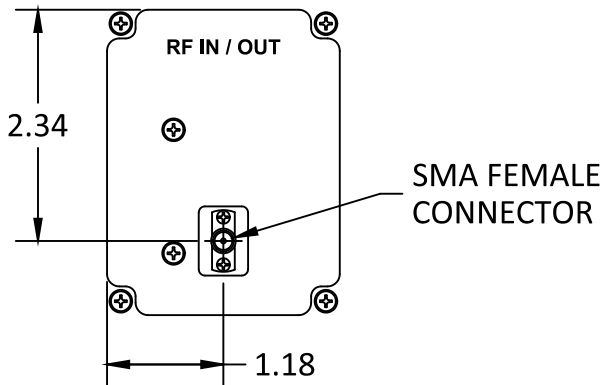

FRONT PANEL

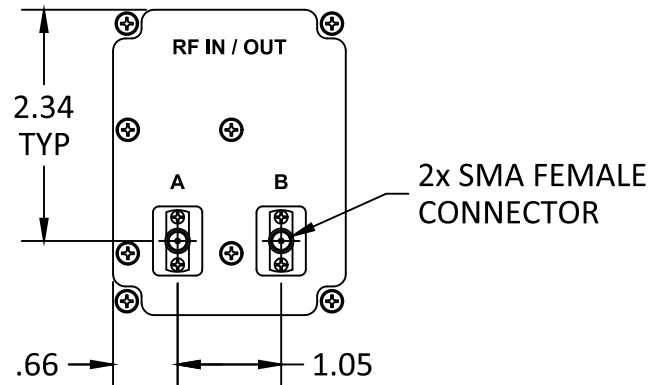

FRONT PANEL

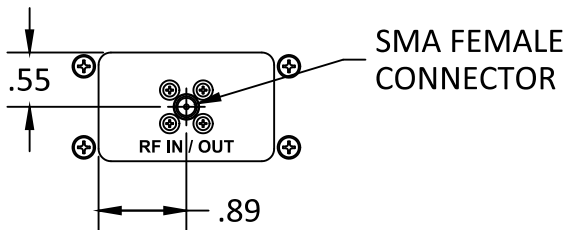

REAR PANEL

SINGLE RUDAT

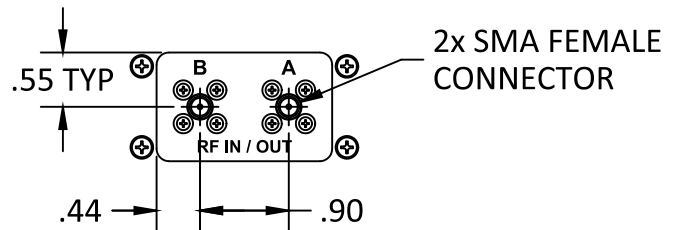

REAR PANEL

DUAL RUDAT

## SPDT Switch Options:

UV2068

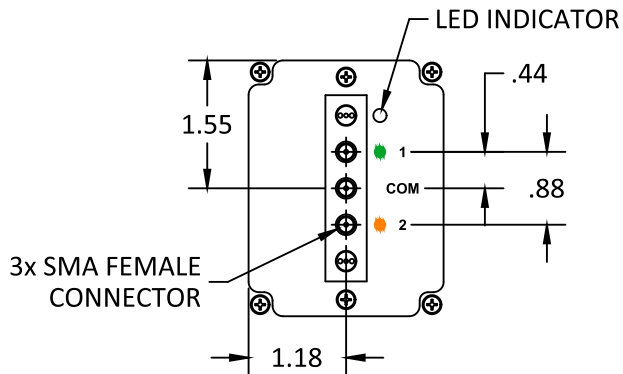

SPDTA 18GHz  
SPDTA 26GHz

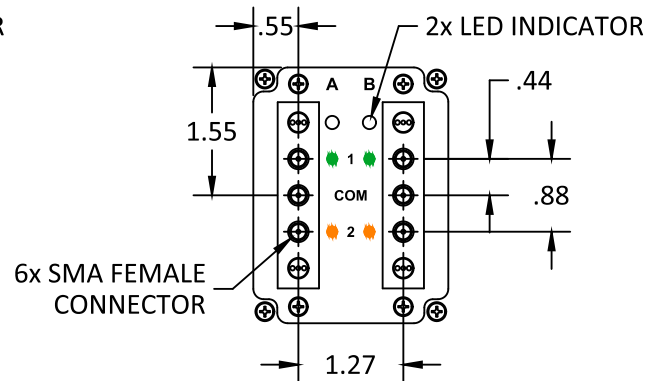

DUAL SPDTA 18GHz  
DUAL SPDTA 26GHz

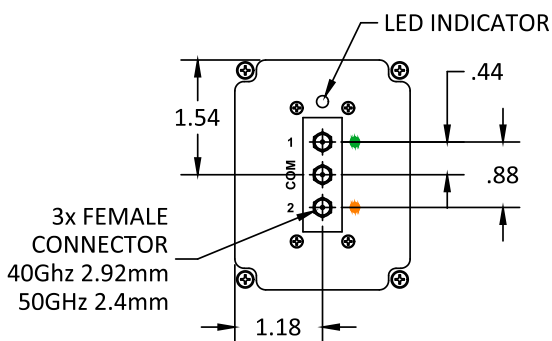

SPDT 40GHz  
SPDT 50GHz

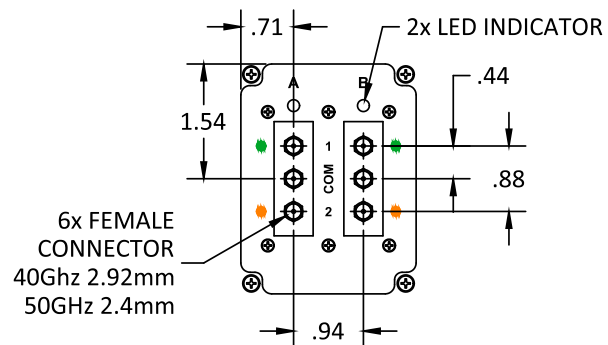

DUAL SPDT 40GHz  
DUAL SPDT 50GHz

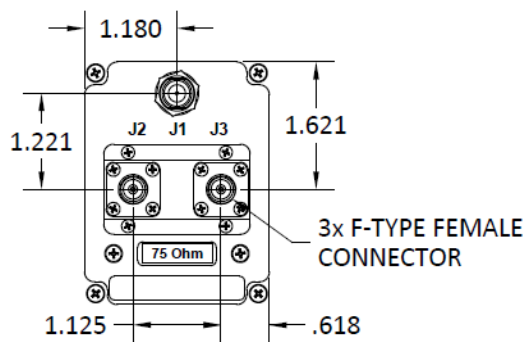

SPDT 2.15GHz

## MTS (Transfer) Switch Options:

UV2068

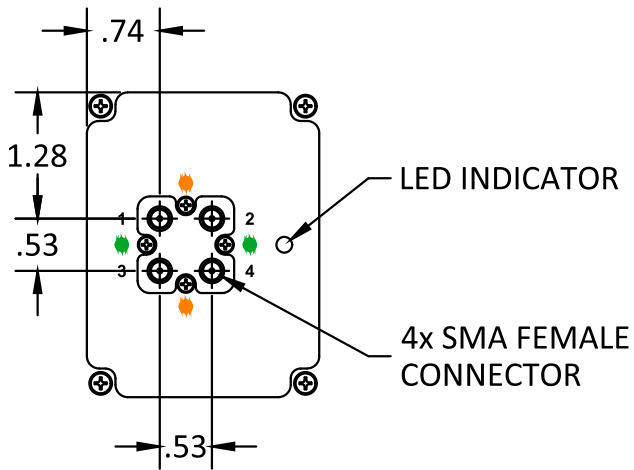

MTS 18GHz

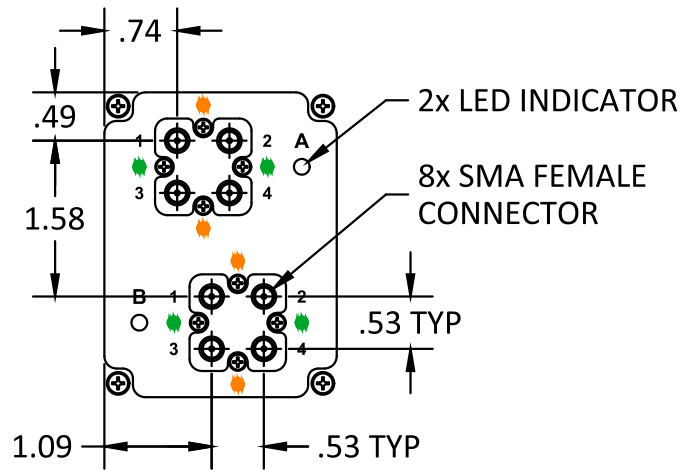

DUAL MTS 18GHz

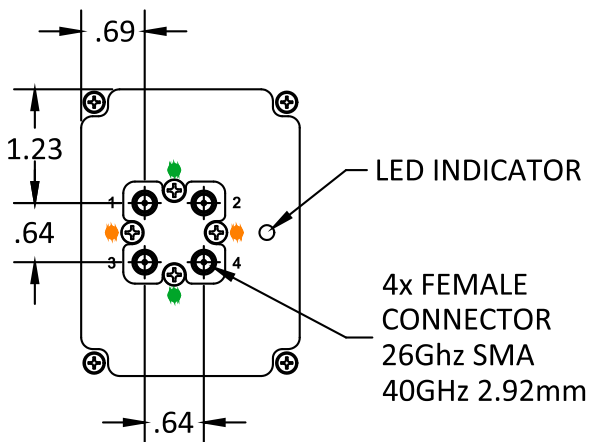

MTS 26GHz

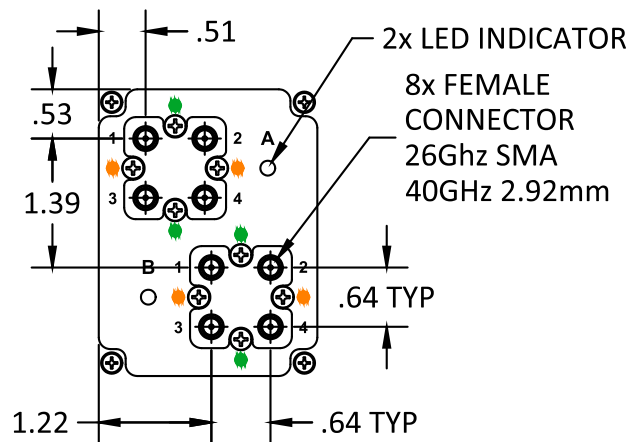

DUAL MTS 26GHz

## SP4T and SP6T Switch Options:

UV2068

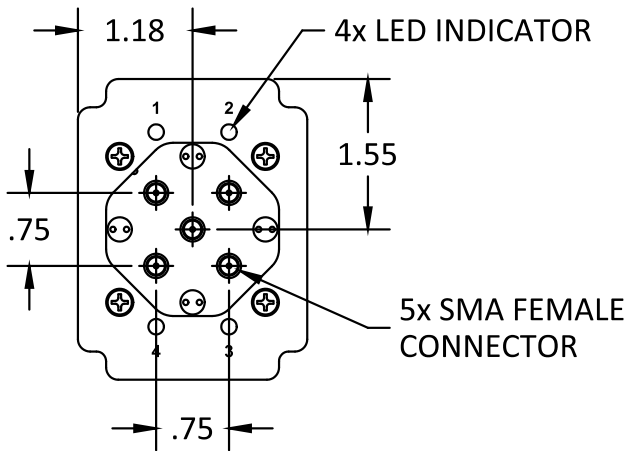

SP4TA 18GHz

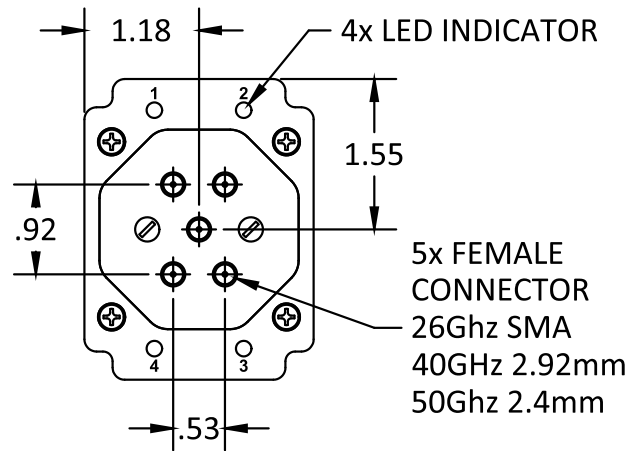

SP4TA 26GHz  
SP4TA 40GHz  
SP4TA 50GHz

5x FEMALE  
CONNECTOR  
26GHz SMA  
40GHz 2.92mm  
50GHz 2.4mm

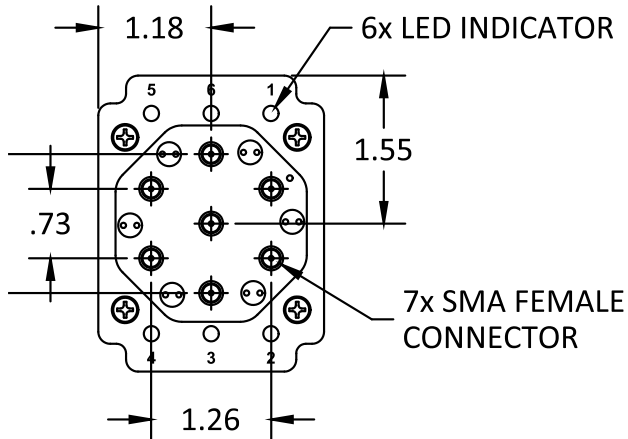

SP6TA 12GHz  
SP6TA 18GHz

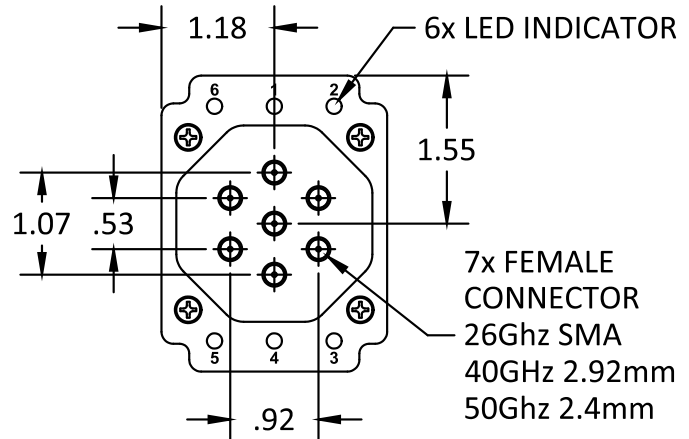

SP6TA 26GHz  
SP6TA 40GHz  
SP6TA 50GHz

7x FEMALE  
CONNECTOR  
26GHz SMA  
40GHz 2.92mm  
50GHz 2.4mm

## SP8T Switch Options:

UV2068

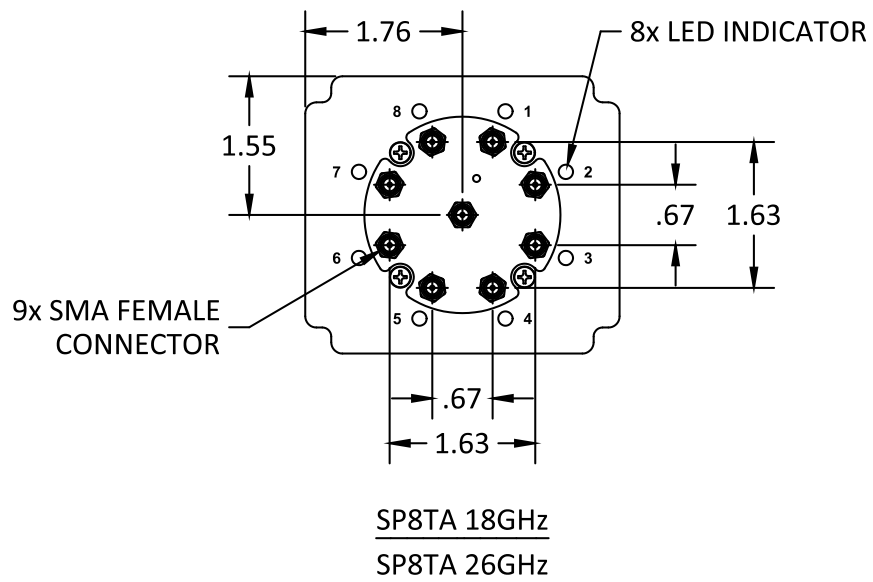
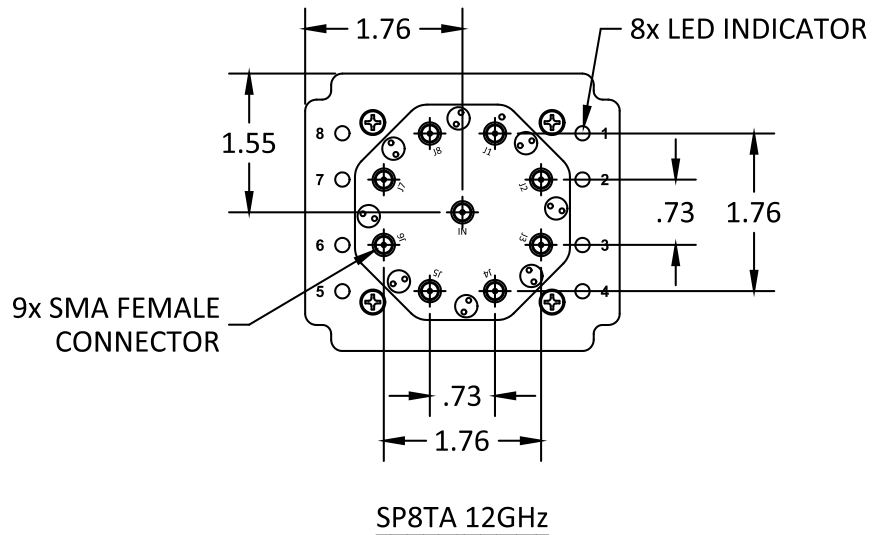

INTERNET <http://www.minicircuits.com>

P.O. Box 350166, Brooklyn, New York 11235-0003 (718) 934-4500 Fax (718) 332-4661

Distribution Centers NORTH AMERICA 800-654-7949 • 417-335-5935 • Fax 417-335-5945 • EUROPE 44-1252-832600 • Fax 44-1252-837010

Mini-Circuits ISO 9001 & ISO 14001 Certified



Environmental Specifications **ENV56**

All Mini-Circuits products are manufactured under exacting quality assurance and control standards, and are capable of meeting published specifications after being subjected to any or all of the following physical and environmental test.

Specification	Test/Inspection Condition	Reference/Spec
Operating Temperature	-0° to 40° C Ambient Environment	Individual Model Data Sheet
Storage Temperature	-15° to 85° C Ambient Environment	Individual Model Data Sheet
Operating and Storage Humidity	5% to 85% RH (non-condensing)	Ambient
Bench Handling Test	Bench Top Tip 45° & Drop	MIL-PRF-28800F
Transit Drop Test	Free Fall Drop, 20 cm (7.9 inches)	MIL-PRF-28800F Class 3