



## USB & ETHERNET CONTROLLED

# Millimeter Wave Switch Matrix **RC-3MTS-50**

50Ω DC to 50 GHz 2.4mm-Female

### THE BIG DEAL

- Millimeter wave switching (up to 50 GHz)
- 3 x mechanical transfer / DPDT switches
- Ethernet & USB control
- High reliability, 2 million switch cycles

### APPLICATIONS

- 5G FR1 & FR2 node / device testing
- Automated test equipment
- Fail-safe / redundancy switching
- Switch matrices



CASE STYLE: SH3143

[DOWNLOAD](#)

SOFTWARE PACKAGE

### RoHS Compliant

See our website for RoHS Compliance methodologies and qualifications

### PRODUCT OVERVIEW

Mini-Circuits' RC-3MTS-50 comprises of three independently controlled, electro-mechanical transfer switches. Each switch operates over a wide bandwidth, from DC to 50 GHz with high isolation (65 dB typical), low insertion loss (0.8 dB typical) and high input power rating. The switches are of a fail-safe and break-before-make-configuration, with a minimum life time of 2 million switching cycles when used within the noted specifications.

The switch box is constructed in a compact, rugged metal case (4.5 x 6.0 x 2.25") with all 2.4 mm connectors on the front panel. The switches are controlled via USB or Ethernet, allowing control directly from a PC, or remotely over a network. Full software support is provided, including our user-friendly GUI application for Windows and a full API with programming instructions for Windows and Linux environments (both 32-bit and 64-bit systems).

### KEY FEATURES

Feature	Advantages
Three transfer switches	Transfer switches provide a simple DPDT switch application (2 input to 2 output switch matrix) and are a useful building block in much larger switch matrices
Fail-safe design	The switches revert to a known default state when the DC supply is removed, allowing their use in systems that must continue to operate safely in the event of power failure
Break-before-make configuration	Prevents a momentary connection of the old and new signal paths, reducing the inconsistent transient effects that could otherwise be observed during switching
USB & Ethernet control	USB HID and Ethernet (HTTP / Telnet) interfaces provide easy compatibility with a wide range of software setups and programming environments
Full software support	User friendly Windows GUI (graphical user interface) allows manual control straight out of the box, while the comprehensive API (application programming interface) with examples and instructions allows easy automation in most programming environments

REV. A  
ECO-015206  
RC-3MTS-40  
MCL NY  
240226





USB & ETHERNET CONTROLLED

# Millimeter Wave Switch Matrix **RC-3MTS-50**

Mini-Circuits

50Ω DC to 50 GHz 2.4mm-Female

## ELECTRICAL SPECIFICATIONS AT 25°C

Parameter	Conditions	Min.	Typ.	Max.	Units
Frequency Range		DC		50	GHz
Insertion Loss	DC - 12 GHz		0.15	0.40	dB
	12 - 26 GHz		0.25	0.70	
	26 - 40 GHz		0.50	0.80	
	40 - 50 GHz		0.80	1.10	
Isolation	DC - 12 GHz	60	85		dB
	12 - 26 GHz	55	80		
	26 - 40 GHz	50	72		
	40 - 50 GHz	50	65		
Return Loss	DC - 12 GHz		19		dB
	12 - 26 GHz		17		
	26 - 40 GHz		14		
	40 - 50 GHz		11		
RF Input Power (Cold Switching) <sup>1</sup>	DC - 12 GHz			20	W
	12 - 26 GHz			10	
	26 - 40 GHz			5	
	40 - 50 GHz			3	
Switching Time			25		ms
Switch Lifetime (per Switch)	Up to 100 mW hot switching <sup>1</sup>	2			million cycles
Rated Voltage	24V <sub>DC</sub> input	23	24	25	V
	USB port		5		
Rated Current (24V DC Input)	All switches in state 2		530		mA
	All switches in state 1		90	120	
Rated Current (USB)			10	20	mA

1. Hot switching above this level will degrade the switch lifetime

## ABSOLUTE MAXIMUM RATINGS

Parameters	Ratings
Operating Temperature	0°C to 40°C
Storage Temperature	-15°C to 85°C
Supply Voltage	26V





# USB & ETHERNET CONTROLLED

# Millimeter Wave Switch Matrix **RC-3MTS-50**

50Ω DC to 50 GHz 2.4mm-Female

## SWITCHING STATES (PER SWITCH)



## CONNECTIONS

Port Name	Connector Type
RF Switch A (J1, J2, J3 & J4)	2.4mm female
RF Switch B (J1, J2, J3 & J4)	2.4mm female
RF Switch C (J1, J2, J3 & J4)	2.4mm female
USB	USB type-B
Ethernet / LAN	RJ45
24V <sub>DC</sub> Input	2.1mm center positive DC socket

## OUTLINE DRAWING (SH3143)

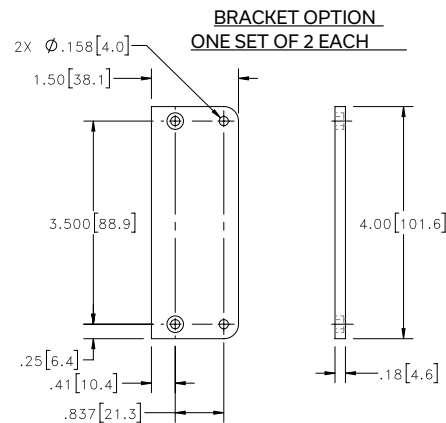
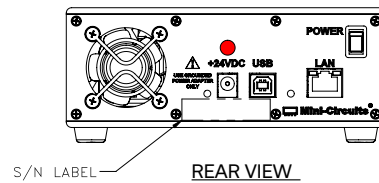
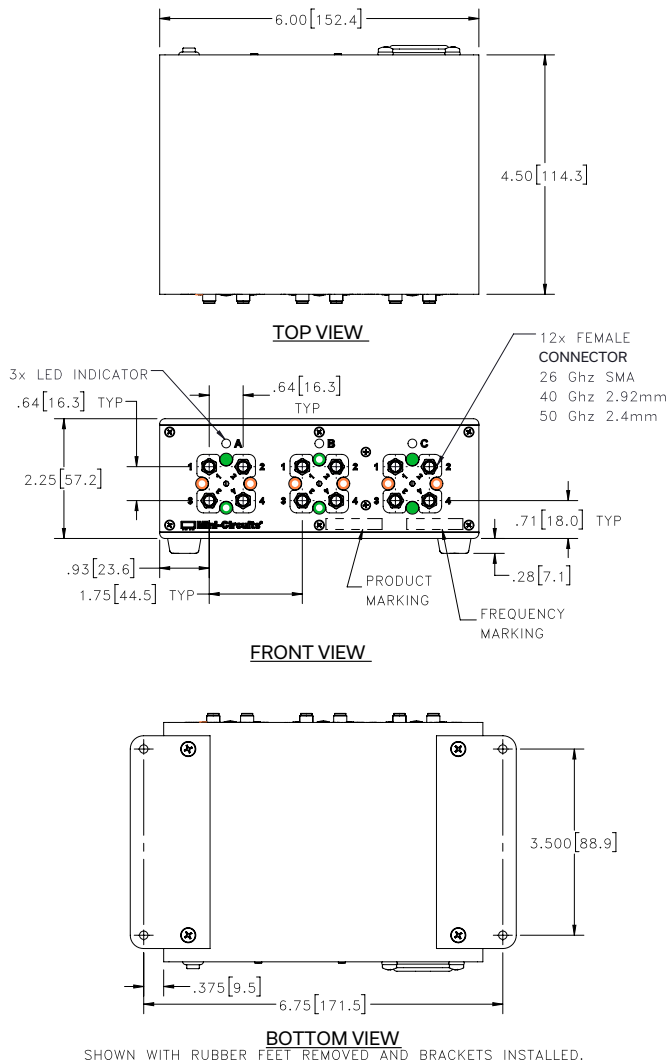

TOLERANCE: ±.005

INSTRUCTIONS FOR MOUNTING BRACKETS:

TOOL REQUIRED: PHILLIPS HEAD SCREWDRIVER

STEP 1: REMOVE RUBBER FEET FROM THE BOTTOM OF THE UNIT. DO NOT DISCARD THE FASTENERS.

STEP 2: MOUNT THE BRACKETS WITH THE FASTENERS REMOVED IN STEP 1. USING THE COUNTER BORE HOLES IN THE BRACKET.

Weight: 960 grams

Dimensions are in inches [mm]. Tolerances: 2 Pl. ±.03 inch; 3Pl. ±.015 inch





USB & ETHERNET CONTROLLED

# Millimeter Wave Switch Matrix **RC-3MTS-50**

50Ω DC to 50 GHz 2.4mm-Female

Insertion Loss

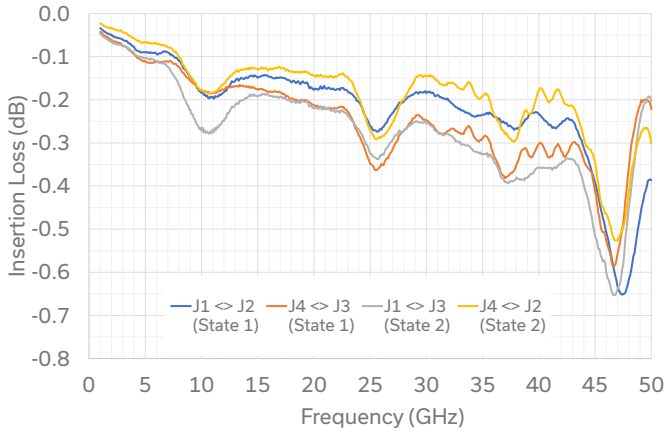

Return Loss

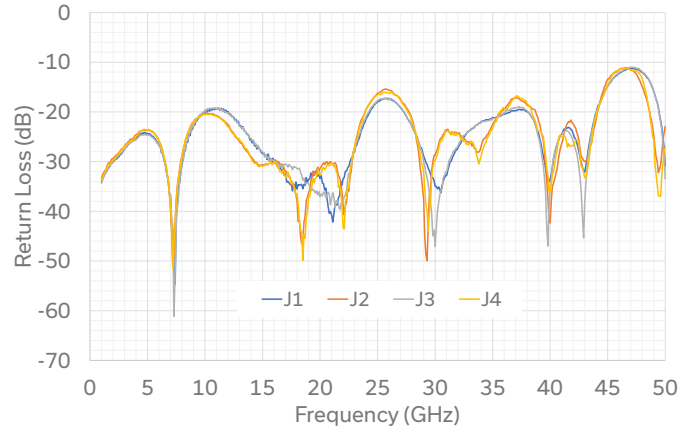

Isolation (Disconnected Paths)

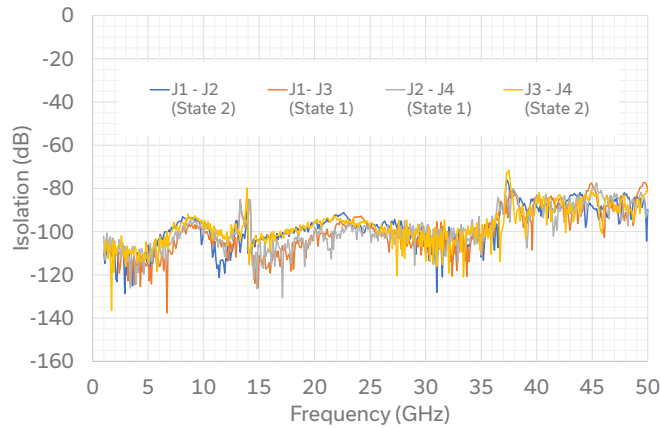



## USB & ETHERNET CONTROLLED

# Millimeter Wave Switch Matrix **RC-3MTS-50**

Mini-Circuits

50Ω DC to 50 GHz 2.4mm-Female

### SOFTWARE SPECIFICATIONS

#### SOFTWARE & DOCUMENTATION DOWNLOAD:

- Mini-Circuits' full software and support package including user guide, Windows GUI, DLL files, programming manual and examples can be downloaded free of charge from: <https://www.minicircuits.com/softwaredownload/rfswitchcontroller.html>
- Please contact [testsolutions@minicircuits.com](mailto:testsolutions@minicircuits.com) for support

#### MINIMUM SYSTEM REQUIREMENTS:

Parameter	Requirements	
Interface	USB HID & Ethernet (HTTP & Telnet)	
System Requirements	GUI	Windows 98 or later
	USB API DLL	Windows 98 or later and programming environment with ActiveX or .NET support
	USB Direct Programming	Linux, Windows 98 or later
	Ethernet	Windows, Linux or Mac computer with a network port and Ethernet TCP/IP support
Hardware	Pentium II or later with 256 MB RAM	

#### APPLICATION PROGRAMMING INTERFACE (API)

##### ETHERNET SUPPORT:

- Simple ASCII / SCPI command set for attenuator control
- Communication via HTTP or Telnet
- Supported by most common programming environment

##### USB SUPPORT (WINDOWS):

- ActiveX COM DLL file for creation of 32-bit programs
- .NET library DLL file for creation of 32 / 64-bit programs
- Supported by most common programming environments (refer to application note AN-49-001 for summary of supported environments)

##### USB SUPPORT (LINUX):

- Direct USB programming using a series of USB interrupt codes

Full programming instructions and examples available for a wide range of programming environments / languages.



## USB & ETHERNET CONTROLLED

# Millimeter Wave Switch Matrix **RC-3MTS-50**

50Ω DC to 50 GHz 2.4mm-Female

### GRAPHICAL USER INTERFACE (GUI) FOR WINDOWS - KEY FEATURES

- Connect via USB or Ethernet
- Run GUI in "demo mode" to evaluate software without a hardware connection

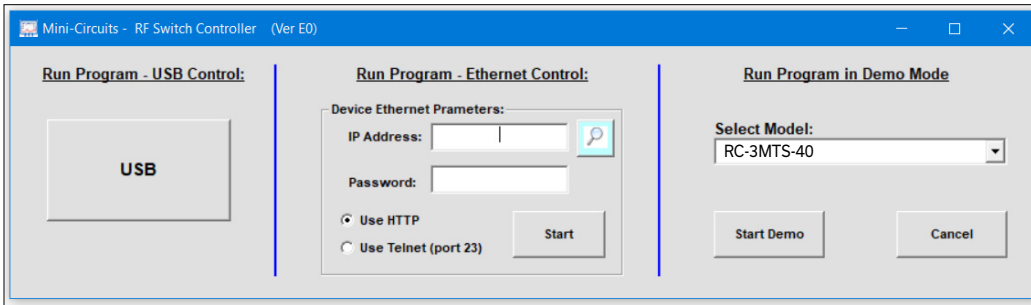

- View and set switch states at the click of a button
- Configure and run timed switching sequences
- Set start-up switch state
- Configure Ethernet IP settings

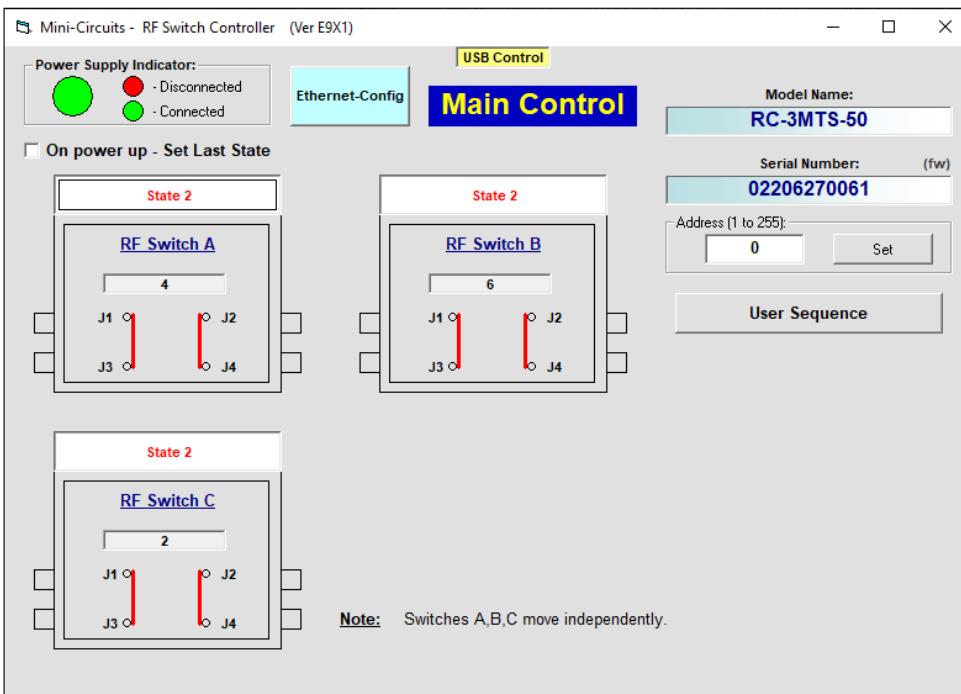



## USB & ETHERNET CONTROLLED

# Millimeter Wave Switch Matrix **RC-3MTS-50**



50Ω DC to 50 GHz 2.4mm-Female





### ORDERING INFORMATION

Refer to Mini-Circuits' website for pricing and availability information:

<https://www.minicircuits.com/WebStore/dashboard.html?model=RC-3MTS-50>

Model	Description
RC-3MTS-50	USB & Ethernet controlled transfer switch matrix

Included Accessories	Part No.	Description
	AC/DC-24-3W1	AC/DC 24V <sub>DC</sub> Grounded Power Adaptor. Operating temperature: 0°C to +40°C, I <sub>Max</sub> =2.5A
See Below	CBL-3W1-XX	AC Power Cord (Select one power cord from below with each Switch Matrix box)
	USB-CBL-AB-3+	2.7 ft (0.8 m) USB Cable: USB type A(Male) to USB type B(Male)

AC Power Cords <sup>3</sup>	Part No.	Description
	CBL-3W1-US	Power Cord for United States
	CBL-3W1-EU	Power Cord for Europe
	CBL-3W1-UK	Power Cord for United Kingdom
	CBL-3W1-AU	Power Cord for Australia and China
	CBL-3W1-IL	Power Cord for Israel

3. If you need a Power cord for a country not listed please contact [testsolutions@minicircuits.com](mailto:testsolutions@minicircuits.com)

### OPTIONAL ACCESSORIES

USB-CBL-AB-3+	2.7 ft (0.8 m) USB Cable: USB type A(Male) to USB type B(Male)
USB-CBL-AB-7+	6.8 ft (2.1 m) USB Cable: USB type A(Male) to USB type B(Male)
USB-CBL-AB-11+	11 ft (3.4 m) USB Cable: USB type A(Male) to USB type B(Male)
CBL-RJ45-MM-5+	5 ft (1.5 m) Ethernet cable: RJ45(Male) to RJ45(Male) Cat 5E cable
BKT-272-08+	Bracket (One set of 2 each)

- NOTES**
- A. Performance and quality attributes and conditions not expressly stated in this specification document are intended to be excluded and do not form a part of this specification document.
  - B. Electrical specifications and performance data contained in this specification document are based on Mini-Circuit's applicable established test performance criteria and measurement instructions.
  - C. The parts covered by this specification document are subject to Mini-Circuits standard limited warranty and terms and conditions (collectively, "Standard Terms"); Purchasers of this part are entitled to the rights and benefits contained therein. For a full statement of the standard. Terms and the exclusive rights and remedies thereunder, please visit Mini-Circuits' website at [www.minicircuits.com/MCLStore/terms.jsp](http://www.minicircuits.com/MCLStore/terms.jsp)



# RF Transfer Switch Matrix

# RC-3MTS-50

## Typical Performance Data per Switch

FREQUENCY (GHz)	INSERTION LOSS (dB)				ISOLATION (dB)				Return Loss (dB)			
	State 1		State 2		State 1		State 2		J1	J2	J3	J4
	J1-J2	J4-J3	J1-J3	J4-J2	J1-J3	J4-J2	J1-J2	J4-J3				
1	-0.03	-0.04	-0.05	-0.02	-109	-102	-109	-110	-34	-33	-34	-34
2	-0.05	-0.06	-0.06	-0.03	-108	-104	-111	-106	-30	-30	-30	-30
3	-0.06	-0.08	-0.08	-0.04	-109	-116	-116	-116	-28	-27	-27	-27
4	-0.08	-0.09	-0.09	-0.06	-110	-116	-110	-115	-25	-25	-26	-25
5	-0.09	-0.11	-0.10	-0.07	-111	-111	-106	-114	-24	-24	-25	-24
6	-0.09	-0.11	-0.11	-0.07	-116	-105	-103	-104	-27	-26	-27	-26
7	-0.09	-0.11	-0.12	-0.08	-109	-105	-100	-101	-37	-39	-36	-39
8	-0.11	-0.12	-0.17	-0.10	-100	-100	-96	-96	-31	-29	-30	-29
9	-0.15	-0.16	-0.22	-0.15	-98	-97	-94	-95	-23	-22	-23	-22
10	-0.18	-0.18	-0.27	-0.18	-99	-101	-99	-98	-20	-20	-20	-21
11	-0.19	-0.18	-0.27	-0.18	-101	-104	-104	-98	-19	-21	-19	-21
12	-0.18	-0.18	-0.25	-0.16	-109	-107	-112	-103	-20	-23	-20	-23
13	-0.16	-0.17	-0.21	-0.14	-105	-99	-95	-100	-23	-26	-23	-26
14	-0.15	-0.17	-0.20	-0.13	-96	-95	-110	-101	-25	-29	-25	-29
15	-0.15	-0.18	-0.19	-0.13	-111	-107	-105	-106	-28	-31	-28	-31
16	-0.15	-0.18	-0.19	-0.13	-119	-108	-104	-109	-30	-30	-30	-30
17	-0.15	-0.18	-0.19	-0.13	-109	-111	-103	-101	-32	-32	-30	-33
18	-0.16	-0.20	-0.21	-0.14	-105	-108	-99	-101	-36	-38	-31	-36
19	-0.16	-0.20	-0.20	-0.13	-106	-105	-99	-97	-34	-36	-34	-37
20	-0.18	-0.21	-0.22	-0.14	-99	-98	-96	-95	-33	-31	-37	-33
21	-0.17	-0.22	-0.22	-0.15	-102	-104	-96	-94	-41	-30	-37	-30
22	-0.18	-0.22	-0.23	-0.15	-96	-103	-92	-95	-33	-39	-38	-43
23	-0.18	-0.23	-0.24	-0.15	-97	-94	-94	-95	-28	-27	-28	-27
24	-0.21	-0.28	-0.27	-0.20	-93	-97	-97	-98	-21	-19	-21	-19
25	-0.26	-0.35	-0.32	-0.27	-98	-99	-96	-97	-18	-16	-18	-16
26	-0.27	-0.35	-0.33	-0.29	-102	-102	-99	-97	-17	-16	-17	-16
27	-0.23	-0.31	-0.29	-0.25	-103	-101	-95	-108	-19	-18	-19	-18
28	-0.20	-0.27	-0.27	-0.20	-98	-106	-98	-99	-23	-22	-23	-22
29	-0.18	-0.24	-0.25	-0.15	-110	-116	-99	-99	-29	-38	-30	-32
30	-0.18	-0.25	-0.25	-0.15	-101	-110	-109	-114	-35	-29	-47	-30
31	-0.19	-0.27	-0.27	-0.16	-95	-104	-128	-116	-33	-24	-32	-24
32	-0.20	-0.27	-0.28	-0.16	-100	-103	-105	-105	-27	-24	-27	-24
33	-0.22	-0.28	-0.30	-0.17	-103	-105	-99	-100	-24	-26	-24	-26
34	-0.24	-0.27	-0.31	-0.17	-107	-105	-105	-99	-22	-27	-22	-29
35	-0.23	-0.29	-0.33	-0.19	-102	-111	-112	-104	-21	-23	-21	-23
36	-0.24	-0.33	-0.34	-0.23	-96	-93	-98	-97	-20	-19	-20	-19
37	-0.25	-0.38	-0.39	-0.28	-91	-91	-92	-97	-20	-17	-19	-17
38	-0.27	-0.35	-0.38	-0.29	-83	-81	-83	-94	-20	-19	-20	-18
39	-0.24	-0.32	-0.38	-0.23	-94	-100	-88	-103	-24	-22	-25	-24
40	-0.23	-0.30	-0.36	-0.18	-83	-84	-89	-85	-34	-42	-35	-36
41	-0.26	-0.33	-0.36	-0.20	-84	-87	-94	-87	-24	-26	-25	-25
42	-0.26	-0.32	-0.35	-0.19	-85	-88	-87	-83	-24	-22	-26	-27
43	-0.25	-0.30	-0.34	-0.21	-99	-84	-83	-87	-32	-30	-38	-33
44	-0.31	-0.34	-0.40	-0.29	-89	-93	-83	-84	-20	-21	-20	-21
45	-0.39	-0.41	-0.52	-0.35	-78	-80	-88	-83	-15	-13	-15	-14
46	-0.51	-0.53	-0.60	-0.46	-100	-84	-90	-91	-12	-11	-12	-12
47	-0.63	-0.56	-0.64	-0.53	-90	-82	-85	-90	-11	-12	-11	-12
48	-0.62	-0.36	-0.45	-0.41	-91	-88	-83	-90	-12	-15	-12	-13
49	-0.47	-0.21	-0.25	-0.29	-83	-88	-84	-85	-16	-25	-16	-26
50	-0.39	-0.22	-0.20	-0.30	-80	-90	-90	-82	-31	-23	-33	-27





## Typical Performance Curves per Switch

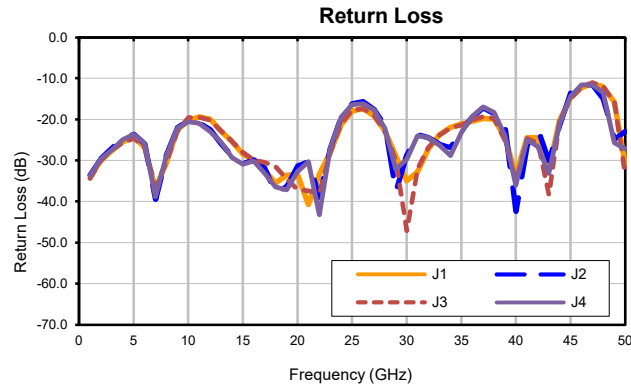
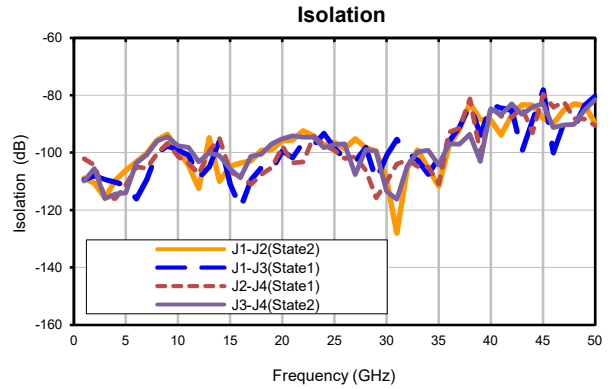
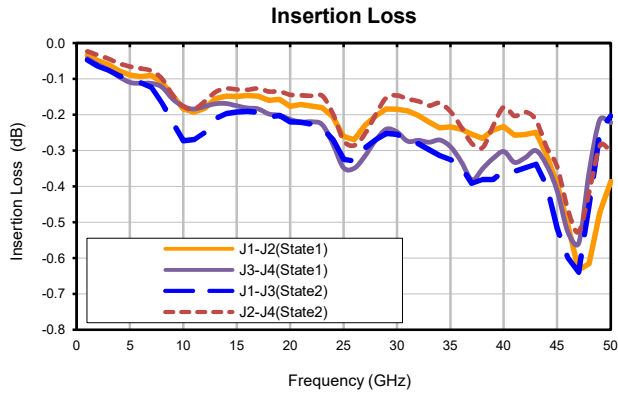

## Outline Dimensions

SH3143

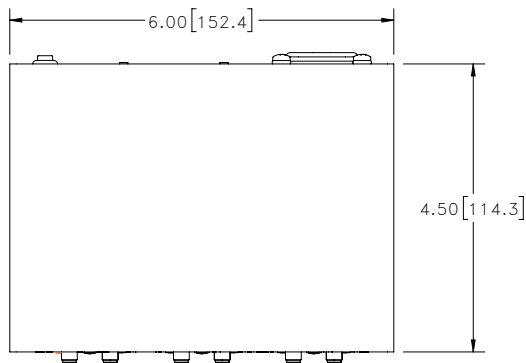

TOP VIEW

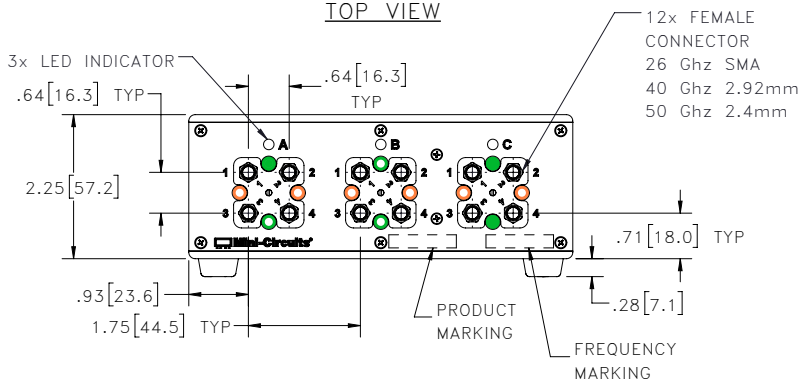

FRONT VIEW

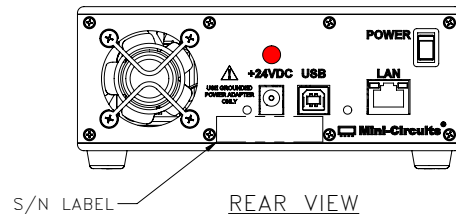

REAR VIEW

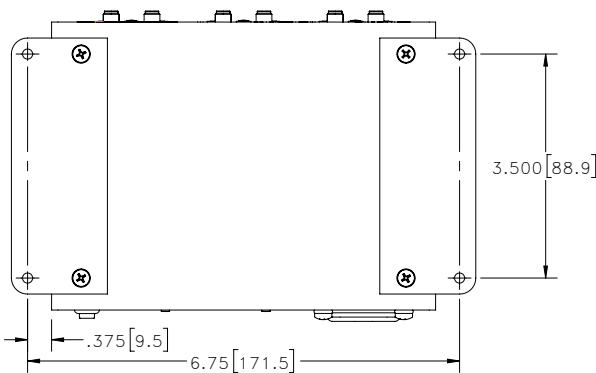

BOTTOM VIEW

SHOWN WITH RUBBER FEET REMOVED AND BRACKETS INSTALLED.

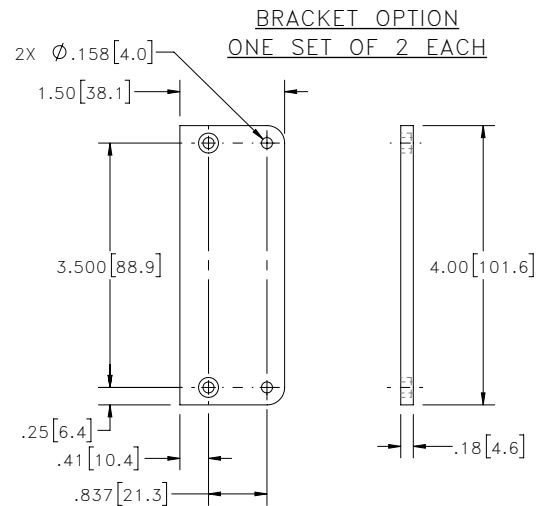

TOLERANCE:  $\pm 0.005$

### Notes:

1. Case material: Aluminum (with protective coating to prevent corrosion).
2. Dimensions are in inches [mm]. Tolerances: 2 Pl.  $\pm 0.03$  inch; 3 Pl.  $\pm 0.015$  inch.
3. Weight: 960 grams.
4. Marking may contain other features or characters for internal lot control.

INSTRUCTIONS FOR MOUNTING BRACKETS:  
 TOOL REQUIRED: PHILLIPS HEAD SCREWDRIVER  
 STEP 1: REMOVE RUBBER FEET FROM THE BOTTOM OF THE UNIT. DO NOT DISCARD THE FASTENERS.  
 STEP 2: MOUNT THE BRACKETS WITH THE FASTENERS REMOVED IN STEP 1, USING THE COUNTER BORE HOLES IN THE BRACKET.



P.O. Box 350166, Brooklyn, New York 11235-0003 (718) 934-4500 Fax (718) 332-4661 For detailed performance specs & shopping online see Mini-Circuits web site



The Design Engineers Search Engine Provides ACTUAL Data Instantly From MINI-CIRCUITS At: [www.minicircuits.com](http://www.minicircuits.com)

RF/IF MICROWAVE COMPONENTS



All Mini-Circuits products are manufactured under exacting quality assurance and control standards, and are capable of meeting published specifications after being subjected to any or all of the following physical and environmental test.

Specification	Test/Inspection Condition	Reference/Spec
Operating Temperature	0° to 40° C Ambient Environment	Individual Model Data Sheet
Storage Temperature	-15° to 85°C Ambient Environment	Individual Model Data Sheet
Operating and Storage Humidity	5% to 85% RH (non-condensing)	Ambient
Bench Handling Test	Bench Top Tip 45° & Drop	MIL-PRF-28800F
Transit Drop Test	Free Fall Drop, 20 cm (7.9 inches)	MIL-PRF-28800F class 3