

# High Power 2 Way-90° Power Splitter

QCH-63B+

50Ω 2 Way-90° Up to 70W\* 800 to 6000 MHz

## The Big Deal

- High power handling up to 70W
- Ultra wide bandwidth
- Good Amplitude Unbalance, 0.80 dB
- Good Phase Unbalance, ±5 deg



CASE STYLE: PQ2181

## Product Overview

Mini-Circuits' new 2-way 90° power splitter, QCH-63B+ capable of handling up to 70W with amplitude unbalance of 0.80 dB typ and phase unbalance of ±5 deg. typ. Operating over a frequency range of 800 to 6000 MHz, the good phase and amplitude unbalance make this component a versatile building block for use in a variety of systems and sub-system designs from balanced amplifiers and antenna feeds to military applications and more. The splitter is fabricated using laminated PCB process (1.8 x 0.4 x 0.19") and includes wrap-around terminations for good solderability and easy visual inspection.

## Key Features

Feature	Advantages
Ultra wide bandwidth	The QCH-63B+ wide band width (800 - 6000 MHz) makes it suitable for a wide range of applications.
High power handling: 70W @ +85°C 50W @ +105°C	Usable in many systems with high-power requirements such as antenna feeds, power amplifiers, and others that require balanced high power outputs.
Good Phase and Amplitude Unbalance: • 0.80 dB Amplitude Unbalance • ±5° Phase Unbalance	QCH-63B+ produces nearly equal signals with 90° phase shift - ideal for I/Q systems, balanced amplifiers, antenna feeds, phase shifters, and many more applications.

\*See power derating on page 2



# High Power Power Splitter/Combiner

## QCH-63B+

50Ω 2 Way-90° Up to 70W\* 800 to 6000 MHz

### Maximum Ratings

Operating Temperature, case**	-55°C to 105°C
Storage Temperature	-55°C to 105°C
Power Input*	70W @ +85°C, case

\*Derate to 60W at +95°C and 50W at +105°C case temperature  
 \*\*Case temperature is defined as temperature on base plate.  
 Permanent damage may occur if any of these limits are exceeded.

### Pad Connections\*\*\*

SUM	1
ISOLATION	2
PORT 1 (0°)	3
PORT 2 (+90°)	4
GROUND	5

\*\*\*Model is symmetrical and all ports are interchangeable, see port configuration table.

### Outline Drawing

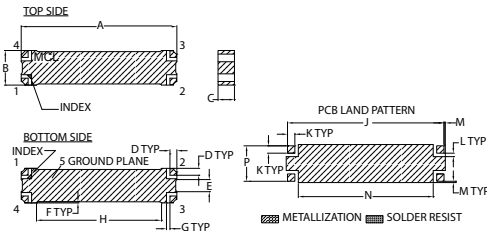

Base material: Printed wiring laminate.  
 Termination Finish: 2-5 µinch (0.05-0.13 microns) Immersion Gold

### Outline Dimensions (inch/mm)

A	B	C	D	E	F	G	
1.800	.400	.190	.080	.140	.013	.040	
45.72	10.16	4.83	2.03	3.56	0.33	1.02	
H	J	K	L	M	N	P	wt.
1.446	1.810	.085	.040	.015	1.560	.410	grams
36.73	45.97	2.16	1.02	0.38	39.62	10.41	1.0

### Demo Board MCL P/N: TB-998+ Suggested PCB Layout (PL-539)

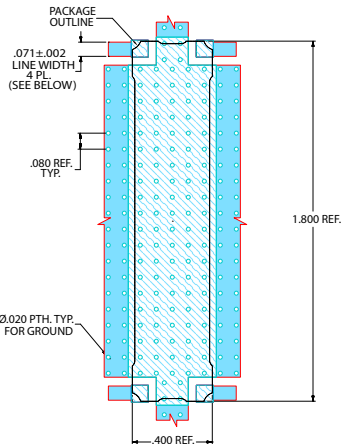

NOTES:  
 1. TRACE WIDTH IS SHOWN FOR ROGERS RO4003C WITH DIELECTRIC THICKNESS. 0.032" ± .003". COPPER: 1 OZ. EACH SIDE.  
 FOR OTHER MATERIALS TRACE WIDTH MAY NEED TO BE MODIFIED.  
 2. BOTTOM SIDE OF THE PCB IS CONTINUOUS GROUND PLANE.  
 ■ DENOTES PCB COPPER LAYOUT WITH SMOBC (SOLDER MASK OVER BARE COPPER)  
 ■ DENOTES COPPER LAND PATTERN FREE OF SOLDERMASK

### Features

- high power, up to 70W
- ultra wide bandwidth
- good amplitude unbalance, 0.80 dB Typ
- good phase unbalance, ±5 deg Typ

### Applications

- Balanced amplifiers
- I&Q Modulators
- Defense and military



CASE STYLE: PQ2181

### +RoHS Compliant

The +Suffix identifies RoHS Compliance. See our web site for RoHS Compliance methodologies and qualifications

### Electrical Specifications @ +25°C

Parameter	Condition (MHz)	Min.	Typ.	Max.	Units
<b>Frequency Range</b>		800		6000	MHz
<b>Insertion Loss</b> (Avg. of Coupled outputs less 3 dB)	800 - 6000	—	0.50	1.10	dB
<b>Isolation</b>	800 - 6000	14.5	20	—	dB
<b>Phase Unbalance</b>	800 - 6000	—	±5	—	deg
<b>Amplitude Unbalance</b> (Peak-to-Peak)	800 - 5800	—	0.80	1.70	dB
	5800 - 6000	—	1.50	2.60	
<b>VSWR</b>	800 - 6000	—	1.20	1.60	:1
<b>Input RF Power</b>	@ +85°C, case	800 - 6000	—	70	W
	@ +95°C, case	800 - 6000	—	60	
	@ +105°C, case	800 - 6000	—	50	
<b>Thermal Resistance</b>	800 - 6000	—	1	—	°C/W

### Electrical Schematic

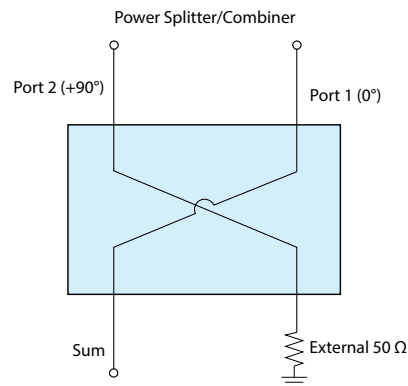

### Port Function Configurations

Config.	Sum	Isolation	Port 1 (0°)	Port 2 (90°)
A	1	2	3	4
B	2	1	4	3
C	3	4	1	2
D	4	3	2	1

## Typical Performance Data <sup>1</sup>

Frequency (MHz)	Total Loss <sup>2</sup> (dB) Sum to Port 1			Total Loss <sup>2</sup> (dB) Sum to Port 2			Amplitude Unbalance (dB) Peak-Peak	Phase Unbalance (deg) Relative to 90°	Isolation (dB) Sum to Isolation			VSWR (:1) Sum Port 1 Port 2 Iso			
	-55°C	+25°C	+105°C	-55°C	+25°C	+105°C			-55°C	+25°C	+105°C	Sum	Port 1	Port 2	Iso
	800	2.51	2.48	2.46	3.89	3.94			3.96	1.46	0.82	25.00	25.50	26.60	1.11
1100	3.30	3.27	3.24	3.00	3.05	3.07	0.22	0.99	26.48	27.76	28.80	1.06	1.05	1.07	1.10
1400	3.73	3.70	3.68	2.68	2.73	2.75	0.97	1.39	25.46	26.07	25.43	1.09	1.09	1.12	1.12
1700	3.87	3.84	3.81	2.64	2.72	2.74	1.13	1.83	22.83	22.25	21.58	1.14	1.15	1.18	1.16
2000	3.82	3.80	3.74	2.80	2.89	2.89	0.91	1.56	19.78	19.44	19.28	1.19	1.20	1.22	1.20
2300	3.73	3.72	3.67	2.99	3.08	3.04	0.64	-0.16	17.85	17.76	17.94	1.23	1.26	1.25	1.26
2600	3.74	3.76	3.67	3.09	3.17	3.12	0.58	-0.88	17.36	17.43	17.76	1.28	1.28	1.26	1.29
2800	3.74	3.75	3.65	3.13	3.22	3.18	0.53	-0.33	17.53	17.81	18.26	1.31	1.26	1.26	1.28
3000	3.61	3.62	3.53	3.16	3.31	3.25	0.31	0.62	18.67	18.84	19.35	1.29	1.21	1.24	1.24
3200	3.41	3.43	3.36	3.31	3.45	3.39	0.03	0.84	20.93	20.59	21.18	1.23	1.14	1.18	1.18
3400	3.22	3.25	3.18	3.44	3.59	3.54	0.34	0.36	25.52	24.02	24.38	1.15	1.07	1.12	1.10
3600	3.13	3.14	3.07	3.57	3.68	3.66	0.53	0.03	33.61	31.33	30.97	1.08	1.04	1.12	1.02
3800	3.06	3.08	3.00	3.70	3.78	3.76	0.70	-0.34	31.14	33.57	32.45	1.02	1.07	1.20	1.10
4100	3.08	3.13	3.03	3.77	3.86	3.83	0.73	-0.88	20.61	22.12	22.16	1.10	1.15	1.31	1.24
4400	3.44	3.48	3.31	3.61	3.82	3.73	0.33	-1.72	17.05	17.93	18.07	1.25	1.26	1.34	1.35
4700	3.93	3.91	3.83	3.38	3.66	3.46	0.25	-0.56	16.05	16.38	16.18	1.39	1.36	1.33	1.43
5000	4.15	4.20	4.16	3.23	3.57	3.29	0.63	0.78	16.25	15.60	15.55	1.48	1.35	1.35	1.47
5300	4.08	4.10	4.10	3.29	3.53	3.37	0.58	1.87	16.55	15.68	15.87	1.45	1.24	1.32	1.45
5500	3.80	3.84	3.79	3.49	3.62	3.55	0.22	1.64	16.94	16.19	16.33	1.38	1.15	1.24	1.40
5800	3.20	3.23	3.18	4.11	4.15	4.17	0.92	0.75	17.72	17.81	17.90	1.29	1.08	1.15	1.25
6000	2.67	2.72	2.70	4.92	4.98	5.03	2.26	-0.21	18.27	18.78	18.85	1.21	1.10	1.18	1.12

1. Data corresponds to Configuration A at +25°C unless specified otherwise.  
 2. Total loss is the loss from Sum to each coupled port including the 3dB theoretical split.

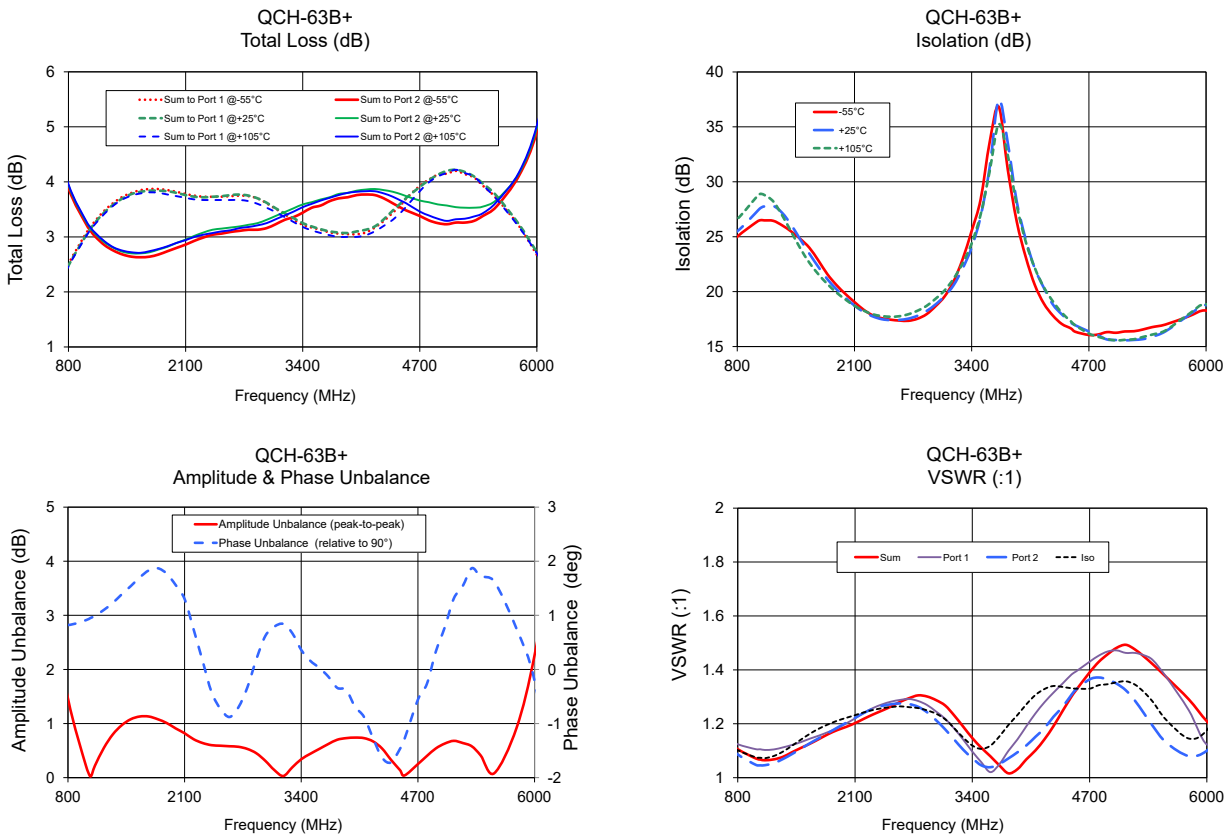

### Additional Notes

- A. Performance and quality attributes and conditions not expressly stated in this specification document are intended to be excluded and do not form a part of this specification document.
- B. Electrical specifications and performance data contained in this specification document are based on Mini-Circuit's applicable established test performance criteria and measurement instructions.
- C. The parts covered by this specification document are subject to Mini-Circuits standard limited warranty and terms and conditions (collectively, "Standard Terms"); Purchasers of this part are entitled to the rights and benefits contained therein. For a full statement of the Standard Terms and the exclusive rights and remedies thereunder, please visit Mini-Circuits' website at [www.minicircuits.com/MCLStore/terms.jsp](http://www.minicircuits.com/MCLStore/terms.jsp)

# 2 Way 90° Power Splitter/Combiner

# QCH-63B+

## Typical Performance Data

Test Conditions: Input Power =+5 dBm @Temperature = -55°C, Configuration A

Freq. (MHz)	Total Loss <sup>1</sup> (dB)			Amp. Unbal. (dB) (Peak-Peak)	Phase Unbal. (deg) (Rel. to 90°)	Isolation (dB) Port 1 - Port 2	VSWR (:1)			
	Sum-Port 1	Sum-Port 2	Avg				Sum	Port 1	Port 2	Iso
400	1.06	7.41	3.17	6.35	1.07	24.11	1.19	1.19	1.18	1.18
600	1.82	5.13	3.17	3.32	0.92	23.38	1.18	1.17	1.17	1.18
800	2.51	3.89	3.15	1.38	0.75	25.00	1.11	1.09	1.10	1.13
1000	3.08	3.22	3.15	0.14	0.94	26.25	1.09	1.07	1.08	1.11
1050	3.19	3.10	3.14	0.10	0.98	26.49	1.09	1.07	1.08	1.11
1100	3.30	3.00	3.15	0.30	1.04	26.48	1.09	1.06	1.07	1.11
1200	3.48	2.85	3.15	0.63	1.17	26.44	1.08	1.07	1.09	1.12
1300	3.62	2.75	3.16	0.87	1.29	26.02	1.09	1.07	1.11	1.13
1400	3.73	2.68	3.17	1.05	1.38	25.46	1.09	1.07	1.12	1.14
1500	3.80	2.64	3.18	1.17	1.53	24.79	1.10	1.09	1.13	1.14
1600	3.85	2.63	3.20	1.23	1.70	23.99	1.11	1.12	1.14	1.14
1700	3.87	2.64	3.21	1.23	1.85	22.83	1.13	1.13	1.17	1.14
1800	3.87	2.68	3.23	1.19	1.96	21.58	1.15	1.15	1.19	1.16
1900	3.85	2.74	3.26	1.12	1.94	20.60	1.16	1.18	1.21	1.17
2000	3.82	2.80	3.28	1.02	1.73	19.78	1.17	1.19	1.22	1.19
2100	3.78	2.86	3.30	0.92	1.44	19.05	1.19	1.21	1.23	1.20
2200	3.75	2.93	3.32	0.82	0.91	18.36	1.21	1.24	1.24	1.22
2300	3.73	2.99	3.34	0.75	0.42	17.85	1.23	1.26	1.25	1.24
2400	3.73	3.04	3.37	0.70	-0.12	17.58	1.25	1.27	1.26	1.25
2500	3.73	3.06	3.38	0.67	-0.51	17.44	1.27	1.28	1.27	1.27
2600	3.74	3.09	3.40	0.66	-0.74	17.36	1.28	1.29	1.27	1.28
2700	3.75	3.11	3.42	0.64	-0.73	17.34	1.30	1.28	1.27	1.29
2800	3.74	3.13	3.42	0.61	-0.53	17.53	1.31	1.27	1.27	1.29
2900	3.70	3.13	3.41	0.57	0.00	17.94	1.31	1.24	1.27	1.28
3000	3.61	3.16	3.38	0.45	0.60	18.67	1.29	1.21	1.24	1.26
3100	3.51	3.23	3.37	0.28	0.97	19.56	1.26	1.17	1.20	1.22
3200	3.41	3.31	3.36	0.11	1.09	20.93	1.23	1.13	1.17	1.18
3300	3.31	3.36	3.33	0.05	1.10	22.95	1.18	1.09	1.14	1.14
3400	3.22	3.44	3.33	0.22	1.02	25.52	1.15	1.08	1.14	1.08
3500	3.17	3.53	3.35	0.36	0.69	28.41	1.11	1.06	1.14	1.03
3600	3.13	3.57	3.34	0.44	0.57	33.61	1.08	1.05	1.15	1.01
3700	3.08	3.65	3.36	0.57	0.37	36.83	1.04	1.06	1.18	1.06
3800	3.06	3.70	3.37	0.63	0.19	31.14	1.01	1.08	1.21	1.12
3900	3.05	3.72	3.37	0.67	0.04	26.38	1.04	1.10	1.24	1.17
4000	3.05	3.76	3.39	0.70	-0.33	23.14	1.08	1.13	1.28	1.24
4100	3.08	3.77	3.41	0.68	-0.75	20.61	1.12	1.17	1.32	1.29
4200	3.17	3.76	3.45	0.58	-1.44	18.92	1.17	1.21	1.33	1.32
4300	3.29	3.70	3.49	0.40	-1.92	17.82	1.22	1.23	1.32	1.34
4400	3.44	3.61	3.52	0.16	-2.11	17.05	1.27	1.27	1.31	1.35
4500	3.60	3.52	3.56	0.09	-2.00	16.65	1.32	1.30	1.31	1.37
4550	3.70	3.48	3.59	0.22	-1.78	16.34	1.35	1.32	1.30	1.38
4700	3.93	3.38	3.65	0.56	-0.76	16.05	1.40	1.34	1.29	1.44
4800	4.04	3.30	3.65	0.74	-0.22	16.09	1.43	1.35	1.30	1.45
4900	4.13	3.25	3.67	0.88	0.48	16.31	1.43	1.35	1.30	1.45
5000	4.15	3.23	3.67	0.92	1.40	16.25	1.43	1.33	1.31	1.45
5100	4.20	3.26	3.70	0.94	1.65	16.37	1.46	1.29	1.32	1.44
5200	4.14	3.26	3.68	0.89	1.94	16.39	1.46	1.26	1.33	1.42
5300	4.08	3.29	3.67	0.79	2.29	16.55	1.44	1.21	1.30	1.41
5400	3.93	3.38	3.65	0.55	2.30	16.76	1.41	1.16	1.27	1.37
5550	3.70	3.55	3.62	0.15	1.75	17.00	1.34	1.12	1.19	1.34
5800	3.20	4.11	3.63	0.92	0.90	17.72	1.28	1.10	1.17	1.22
6000	2.67	4.92	3.65	2.26	-0.12	18.27	1.20	1.12	1.17	1.12
6200	2.10	6.46	3.75	4.36	-1.42	17.10	1.16	1.23	1.28	1.16
6400	1.63	9.19	3.94	7.57	-5.14	14.59	1.25	1.32	1.45	1.39

Note 1 Total loss is the loss from Sum to each coupled port including the 3dB theoretical split.

**Notes**

- A. Performance and quality attributes and conditions not expressly stated in this specification document are intended to be excluded and do not form a part of this specification document.
- B. Electrical specifications and performance data contained in this specification document are based on Mini-Circuits' applicable established test performance criteria and measurement instructions.
- C. The parts covered by this specification document are subject to Mini-Circuits' standard limited warranty and terms and conditions (collectively, "Standard Terms"); Purchasers of this part are entitled to the rights and benefits contained therein. For a full statement of the Standard Terms and the exclusive rights and remedies thereunder, please visit Mini-Circuits' website at [www.minicircuits.com/MCUStore/terms.jsp](http://www.minicircuits.com/MCUStore/terms.jsp)



# 2 Way 90° Power Splitter/Combiner

# QCH-63B+

## Typical Performance Data

Test Conditions: Input Power =+5 dBm @Temperature = -55°C, Configuration B

Freq. (MHz)	Total Loss <sup>1</sup> (dB)			Amp. Unbal. (dB) (Peak-Peak)	Phase Unbal. (deg) (Rel. to 90°)	Isolation (dB) Port 1 - Port 2	VSWR (:1)			
	Sum-Port 1	Sum-Port 2	Avg				Sum	Port 1	Port 2	Iso
400	1.06	7.41	3.17	6.36	0.39	24.10	1.18	1.18	1.19	1.19
600	1.82	5.14	3.17	3.33	-0.15	23.39	1.18	1.17	1.17	1.18
800	2.51	3.89	3.15	1.39	-0.62	25.02	1.13	1.10	1.09	1.11
1000	3.08	3.22	3.15	0.15	-0.81	26.25	1.11	1.08	1.07	1.09
1050	3.20	3.11	3.15	0.08	-0.86	26.51	1.11	1.08	1.07	1.09
1100	3.30	3.01	3.15	0.29	-0.89	26.43	1.11	1.07	1.06	1.09
1200	3.49	2.86	3.16	0.62	-0.95	26.39	1.12	1.09	1.07	1.08
1300	3.63	2.76	3.17	0.87	-1.01	26.00	1.13	1.11	1.07	1.09
1400	3.74	2.69	3.18	1.05	-1.03	25.46	1.14	1.12	1.07	1.09
1500	3.82	2.65	3.20	1.17	-1.03	24.82	1.14	1.13	1.09	1.10
1600	3.86	2.64	3.21	1.22	-1.02	23.96	1.14	1.14	1.12	1.11
1700	3.89	2.64	3.22	1.24	-1.03	22.81	1.14	1.17	1.13	1.13
1800	3.89	2.68	3.24	1.21	-0.99	21.57	1.16	1.19	1.15	1.15
1900	3.86	2.73	3.26	1.13	-1.07	20.57	1.17	1.21	1.18	1.16
2000	3.83	2.79	3.28	1.03	-1.30	19.75	1.19	1.22	1.19	1.17
2100	3.79	2.86	3.30	0.92	-1.59	18.98	1.20	1.23	1.21	1.19
2200	3.75	2.93	3.32	0.81	-2.16	18.30	1.22	1.24	1.24	1.21
2300	3.73	2.99	3.34	0.73	-2.82	17.81	1.24	1.25	1.26	1.23
2400	3.72	3.03	3.36	0.68	-3.42	17.58	1.25	1.26	1.27	1.25
2500	3.72	3.05	3.37	0.66	-3.80	17.43	1.27	1.27	1.28	1.27
2600	3.73	3.07	3.39	0.65	-4.05	17.33	1.28	1.27	1.29	1.28
2700	3.73	3.07	3.39	0.65	-3.99	17.31	1.29	1.27	1.28	1.30
2800	3.73	3.08	3.39	0.65	-3.67	17.49	1.29	1.27	1.27	1.31
2900	3.70	3.10	3.39	0.59	-3.03	17.95	1.28	1.27	1.24	1.31
3000	3.60	3.14	3.36	0.46	-2.41	18.71	1.26	1.24	1.21	1.29
3100	3.51	3.19	3.35	0.31	-2.04	19.57	1.22	1.20	1.17	1.26
3200	3.41	3.26	3.33	0.14	-1.78	20.93	1.18	1.17	1.13	1.23
3300	3.30	3.32	3.31	0.02	-1.68	22.92	1.14	1.14	1.09	1.18
3400	3.22	3.41	3.31	0.19	-1.69	25.46	1.08	1.14	1.08	1.15
3500	3.17	3.49	3.33	0.32	-1.88	28.32	1.03	1.14	1.06	1.11
3600	3.12	3.53	3.32	0.41	-1.95	33.23	1.01	1.15	1.05	1.08
3700	3.10	3.62	3.35	0.53	-2.07	36.67	1.06	1.18	1.06	1.04
3800	3.11	3.68	3.39	0.57	-2.27	31.19	1.12	1.21	1.08	1.01
3900	3.12	3.70	3.40	0.58	-2.21	26.34	1.17	1.24	1.10	1.04
4000	3.15	3.75	3.44	0.61	-2.49	23.05	1.24	1.28	1.13	1.08
4100	3.19	3.78	3.47	0.59	-2.68	20.56	1.29	1.32	1.17	1.12
4200	3.28	3.76	3.51	0.48	-3.13	18.93	1.32	1.33	1.21	1.17
4300	3.37	3.70	3.53	0.32	-3.39	17.83	1.34	1.32	1.23	1.22
4400	3.49	3.64	3.56	0.14	-3.65	17.05	1.35	1.31	1.27	1.27
4500	3.62	3.52	3.57	0.10	-3.54	16.64	1.37	1.31	1.30	1.32
4550	3.70	3.50	3.60	0.20	-3.46	16.33	1.38	1.30	1.32	1.35
4700	3.91	3.39	3.64	0.52	-3.02	16.05	1.44	1.29	1.34	1.40
4800	4.03	3.35	3.68	0.68	-2.49	16.09	1.45	1.30	1.35	1.43
4900	4.10	3.29	3.68	0.81	-2.28	16.29	1.45	1.30	1.35	1.43
5000	4.13	3.26	3.67	0.87	-1.88	16.22	1.45	1.31	1.33	1.43
5100	4.16	3.24	3.68	0.92	-1.88	16.35	1.44	1.32	1.29	1.46
5200	4.13	3.26	3.67	0.86	-1.55	16.37	1.42	1.33	1.26	1.46
5300	4.05	3.31	3.66	0.74	-1.76	16.52	1.41	1.30	1.21	1.44
5400	3.93	3.32	3.61	0.61	-2.08	16.73	1.37	1.27	1.16	1.41
5550	3.71	3.51	3.61	0.19	-2.67	16.92	1.34	1.19	1.12	1.34
5800	3.19	4.03	3.59	0.84	-4.26	17.68	1.22	1.17	1.10	1.28
6000	2.66	4.85	3.62	2.20	-5.98	18.23	1.12	1.17	1.12	1.20
6200	2.11	6.39	3.74	4.28	-8.69	17.09	1.16	1.28	1.23	1.16
6400	1.72	9.10	4.00	7.40	-13.53	14.63	1.39	1.45	1.32	1.25

Note 1 Total loss is the loss from Sum to each coupled port including the 3dB theoretical split.

**Notes**

- A. Performance and quality attributes and conditions not expressly stated in this specification document are intended to be excluded and do not form a part of this specification document.
- B. Electrical specifications and performance data contained in this specification document are based on Mini-Circuits' applicable established test performance criteria and measurement instructions.
- C. The parts covered by this specification document are subject to Mini-Circuits' standard limited warranty and terms and conditions (collectively, "Standard Terms"); Purchasers of this part are entitled to the rights and benefits contained therein. For a full statement of the Standard Terms and the exclusive rights and remedies thereunder, please visit Mini-Circuits' website at [www.minicircuits.com/MCStore/terms.jsp](http://www.minicircuits.com/MCStore/terms.jsp)



# 2 Way 90° Power Splitter/Combiner

# QCH-63B+

## Typical Performance Data

Test Conditions: Input Power =+5 dBm @Temperature = -55°C, Configuration C

Freq. (MHz)	Total Loss <sup>1</sup> (dB)			Amp. Unbal. (dB) (Peak-Peak)	Phase Unbal. (deg) (Rel. to 90°)	Isolation (dB) Port 1 - Port 2	VSWR (:1)			
	Sum-Port 1	Sum-Port 2	Avg				Sum	Port 1	Port 2	Iso
400	1.07	7.42	3.18	6.35	0.66	24.66	1.19	1.19	1.18	1.18
600	1.82	5.14	3.17	3.32	0.26	24.71	1.17	1.18	1.18	1.17
800	2.52	3.90	3.16	1.38	-0.12	27.61	1.09	1.11	1.13	1.10
1000	3.08	3.23	3.15	0.15	-0.14	28.56	1.07	1.09	1.11	1.08
1050	3.20	3.11	3.15	0.08	-0.15	29.07	1.07	1.09	1.11	1.08
1100	3.31	3.02	3.16	0.29	-0.15	29.08	1.06	1.09	1.11	1.07
1200	3.49	2.87	3.17	0.61	-0.14	28.11	1.07	1.08	1.12	1.09
1300	3.63	2.76	3.17	0.86	-0.11	27.07	1.07	1.09	1.13	1.11
1400	3.73	2.69	3.18	1.04	-0.11	26.10	1.07	1.09	1.14	1.12
1500	3.81	2.65	3.19	1.15	-0.06	24.57	1.09	1.10	1.14	1.13
1600	3.86	2.64	3.21	1.22	-0.03	23.07	1.12	1.11	1.14	1.14
1700	3.88	2.64	3.22	1.23	0.06	21.79	1.13	1.13	1.14	1.17
1800	3.88	2.68	3.24	1.19	0.15	20.58	1.15	1.15	1.16	1.19
1900	3.86	2.73	3.26	1.12	0.13	19.59	1.18	1.16	1.17	1.21
2000	3.82	2.80	3.28	1.02	-0.05	18.89	1.19	1.17	1.19	1.22
2100	3.79	2.86	3.30	0.92	-0.38	18.30	1.21	1.19	1.20	1.23
2200	3.76	2.93	3.33	0.82	-0.89	17.87	1.24	1.21	1.22	1.24
2300	3.74	2.99	3.35	0.74	-1.39	17.66	1.26	1.23	1.24	1.25
2400	3.73	3.03	3.37	0.70	-1.93	17.57	1.27	1.25	1.25	1.26
2500	3.73	3.05	3.38	0.68	-2.23	17.51	1.28	1.27	1.27	1.27
2600	3.74	3.07	3.39	0.67	-2.38	17.66	1.29	1.28	1.28	1.27
2700	3.75	3.07	3.40	0.67	-2.25	18.08	1.28	1.30	1.29	1.27
2800	3.74	3.08	3.40	0.66	-1.82	18.61	1.27	1.31	1.29	1.27
2900	3.71	3.10	3.39	0.60	-1.10	19.33	1.24	1.31	1.28	1.27
3000	3.62	3.14	3.37	0.48	-0.40	20.41	1.21	1.29	1.26	1.24
3100	3.52	3.20	3.36	0.32	0.08	21.80	1.17	1.26	1.22	1.20
3200	3.42	3.26	3.34	0.15	0.44	23.37	1.13	1.23	1.18	1.17
3300	3.32	3.33	3.32	0.01	0.66	24.97	1.09	1.18	1.14	1.14
3400	3.23	3.41	3.32	0.19	0.73	25.47	1.08	1.15	1.08	1.14
3500	3.17	3.49	3.33	0.32	0.64	25.84	1.06	1.11	1.03	1.14
3600	3.14	3.54	3.34	0.41	0.70	25.86	1.05	1.08	1.01	1.15
3700	3.08	3.62	3.34	0.54	0.69	24.57	1.06	1.04	1.06	1.18
3800	3.07	3.68	3.36	0.62	0.62	23.61	1.08	1.01	1.12	1.21
3900	3.06	3.70	3.37	0.65	0.62	22.32	1.10	1.04	1.17	1.24
4000	3.06	3.75	3.39	0.70	0.27	21.00	1.13	1.08	1.24	1.28
4100	3.10	3.78	3.43	0.69	-0.06	19.96	1.17	1.12	1.29	1.32
4200	3.19	3.76	3.47	0.58	-0.66	19.23	1.21	1.17	1.32	1.33
4300	3.30	3.69	3.49	0.41	-1.06	18.78	1.23	1.22	1.34	1.32
4400	3.45	3.63	3.54	0.20	-1.34	18.35	1.27	1.27	1.35	1.31
4500	3.62	3.52	3.57	0.08	-1.17	18.25	1.30	1.32	1.37	1.31
4550	3.71	3.50	3.60	0.20	-1.03	18.32	1.32	1.35	1.38	1.30
4700	3.95	3.40	3.67	0.54	-0.28	19.19	1.34	1.40	1.44	1.29
4800	4.06	3.35	3.69	0.70	0.32	19.49	1.35	1.43	1.45	1.30
4900	4.14	3.29	3.69	0.84	0.72	19.87	1.35	1.43	1.45	1.30
5000	4.16	3.27	3.69	0.88	1.24	20.24	1.33	1.43	1.45	1.31
5100	4.21	3.25	3.70	0.96	1.40	20.69	1.29	1.46	1.44	1.32
5200	4.15	3.27	3.69	0.88	1.71	20.99	1.26	1.46	1.42	1.33
5300	4.09	3.31	3.68	0.77	1.67	21.78	1.21	1.44	1.41	1.30
5400	3.94	3.32	3.62	0.61	1.40	22.60	1.16	1.41	1.37	1.27
5550	3.70	3.52	3.61	0.19	0.84	23.26	1.12	1.34	1.34	1.19
5800	3.20	4.03	3.60	0.83	-0.67	22.82	1.10	1.28	1.22	1.17
6000	2.67	4.85	3.62	2.19	-2.21	21.85	1.12	1.20	1.12	1.17
6200	2.10	6.39	3.74	4.28	-4.56	18.35	1.23	1.16	1.16	1.28
6400	1.63	9.10	3.92	7.47	-9.35	15.73	1.32	1.25	1.39	1.45

Note 1 Total loss is the loss from Sum to each coupled port including the 3dB theoretical split.

Notes

- A. Performance and quality attributes and conditions not expressly stated in this specification document are intended to be excluded and do not form a part of this specification document.
- B. Electrical specifications and performance data contained in this specification document are based on Mini-Circuits' applicable established test performance criteria and measurement instructions.
- C. The parts covered by this specification document are subject to Mini-Circuits' standard limited warranty and terms and conditions (collectively, "Standard Terms"); Purchasers of this part are entitled to the rights and benefits contained therein. For a full statement of the Standard Terms and the exclusive rights and remedies thereunder, please visit Mini-Circuits' website at [www.minicircuits.com/MCStore/terms.jsp](http://www.minicircuits.com/MCStore/terms.jsp)





# 2 Way 90° Power Splitter/Combiner

# QCH-63B+

## Typical Performance Data

Test Conditions: Input Power =+5 dBm @Temperature = -55°C, Configuration D

Freq. (MHz)	Total Loss <sup>1</sup> (dB)			Amp. Unbal. (dB) (Peak-Peak)	Phase Unbal. (deg) (Rel. to 90°)	Isolation (dB) Port 1 - Port 2	VSWR (:1)			
	Sum-Port 1	Sum-Port 2	Avg				Sum	Port 1	Port 2	Iso
400	1.06	7.42	3.17	6.35	0.82	24.65	1.18	1.18	1.19	1.19
600	1.81	5.14	3.16	3.32	0.50	24.74	1.17	1.18	1.18	1.17
800	2.51	3.89	3.15	1.38	0.26	27.62	1.10	1.13	1.11	1.09
1000	3.08	3.22	3.15	0.13	0.27	28.51	1.08	1.11	1.09	1.07
1050	3.20	3.10	3.15	0.10	0.28	29.10	1.08	1.11	1.09	1.07
1100	3.30	3.01	3.15	0.30	0.31	29.06	1.07	1.11	1.09	1.06
1200	3.48	2.86	3.16	0.63	0.35	28.09	1.09	1.12	1.08	1.07
1300	3.63	2.75	3.17	0.89	0.40	27.07	1.11	1.13	1.09	1.07
1400	3.74	2.69	3.18	1.06	0.46	26.11	1.12	1.14	1.09	1.07
1500	3.82	2.64	3.19	1.18	0.57	24.58	1.13	1.14	1.10	1.09
1600	3.86	2.63	3.20	1.24	0.70	23.06	1.14	1.14	1.11	1.12
1700	3.89	2.65	3.23	1.24	0.76	21.76	1.17	1.14	1.13	1.13
1800	3.89	2.69	3.25	1.21	0.83	20.57	1.19	1.16	1.15	1.15
1900	3.86	2.74	3.26	1.13	0.77	19.59	1.21	1.17	1.16	1.18
2000	3.83	2.80	3.28	1.04	0.51	18.89	1.22	1.19	1.17	1.19
2100	3.79	2.87	3.31	0.93	0.24	18.33	1.23	1.20	1.19	1.21
2200	3.74	2.94	3.32	0.81	-0.34	17.89	1.24	1.22	1.21	1.24
2300	3.72	2.99	3.34	0.74	-0.99	17.66	1.25	1.24	1.23	1.26
2400	3.71	3.04	3.36	0.68	-1.58	17.57	1.26	1.25	1.25	1.27
2500	3.71	3.06	3.37	0.66	-2.08	17.51	1.27	1.27	1.27	1.28
2600	3.72	3.09	3.39	0.64	-2.41	17.67	1.27	1.28	1.28	1.29
2700	3.73	3.11	3.41	0.62	-2.47	18.09	1.27	1.29	1.30	1.28
2800	3.73	3.13	3.42	0.61	-2.40	18.60	1.27	1.29	1.31	1.27
2900	3.69	3.13	3.40	0.57	-1.93	19.30	1.27	1.28	1.31	1.24
3000	3.60	3.17	3.38	0.44	-1.42	20.38	1.24	1.26	1.29	1.21
3100	3.50	3.24	3.37	0.27	-1.16	21.74	1.20	1.22	1.26	1.17
3200	3.40	3.31	3.35	0.10	-1.13	23.34	1.17	1.18	1.23	1.13
3300	3.30	3.37	3.33	0.06	-1.23	24.93	1.14	1.14	1.18	1.09
3400	3.22	3.45	3.33	0.22	-1.40	25.46	1.14	1.08	1.15	1.08
3500	3.17	3.54	3.35	0.36	-1.82	25.88	1.14	1.03	1.11	1.06
3600	3.12	3.58	3.34	0.45	-2.06	25.86	1.15	1.01	1.08	1.05
3700	3.10	3.65	3.37	0.55	-2.40	24.56	1.18	1.06	1.04	1.06
3800	3.10	3.70	3.39	0.59	-2.71	23.58	1.21	1.12	1.01	1.08
3900	3.12	3.72	3.41	0.60	-2.81	22.26	1.24	1.17	1.04	1.10
4000	3.15	3.76	3.44	0.61	-3.08	20.93	1.28	1.24	1.08	1.13
4100	3.19	3.78	3.47	0.59	-3.38	19.94	1.32	1.29	1.12	1.17
4200	3.27	3.76	3.51	0.48	-3.93	19.20	1.33	1.32	1.17	1.21
4300	3.37	3.70	3.53	0.33	-4.25	18.78	1.32	1.34	1.22	1.23
4400	3.50	3.62	3.56	0.12	-4.40	18.34	1.31	1.35	1.27	1.27
4500	3.62	3.53	3.57	0.10	-4.29	18.25	1.31	1.37	1.32	1.30
4550	3.70	3.49	3.59	0.22	-4.16	18.30	1.30	1.38	1.35	1.32
4700	3.91	3.39	3.64	0.53	-3.49	19.15	1.29	1.44	1.40	1.34
4800	4.03	3.31	3.66	0.72	-3.00	19.49	1.30	1.45	1.43	1.35
4900	4.11	3.26	3.66	0.86	-2.47	19.86	1.30	1.45	1.43	1.35
5000	4.13	3.24	3.66	0.90	-1.65	20.27	1.31	1.45	1.43	1.33
5100	4.17	3.27	3.70	0.90	-1.57	20.73	1.32	1.44	1.46	1.29
5200	4.13	3.27	3.68	0.87	-1.26	21.04	1.33	1.42	1.46	1.26
5300	4.05	3.30	3.66	0.76	-1.11	21.82	1.30	1.41	1.44	1.21
5400	3.93	3.39	3.65	0.54	-1.16	22.65	1.27	1.37	1.41	1.16
5550	3.71	3.55	3.63	0.16	-1.84	23.44	1.19	1.34	1.34	1.12
5800	3.19	4.12	3.63	0.92	-2.85	22.97	1.17	1.22	1.28	1.10
6000	2.65	4.93	3.64	2.27	-4.08	22.02	1.17	1.12	1.20	1.12
6200	2.11	6.47	3.76	4.34	-5.78	18.45	1.28	1.16	1.16	1.23
6400	1.71	9.20	4.01	7.47	-9.43	15.78	1.45	1.39	1.25	1.32

Note 1 Total loss is the loss from Sum to each coupled port including the 3dB theoretical split.

**Notes**

- A. Performance and quality attributes and conditions not expressly stated in this specification document are intended to be excluded and do not form a part of this specification document.
- B. Electrical specifications and performance data contained in this specification document are based on Mini-Circuits' applicable established test performance criteria and measurement instructions.
- C. The parts covered by this specification document are subject to Mini-Circuits' standard limited warranty and terms and conditions (collectively, "Standard Terms"); Purchasers of this part are entitled to the rights and benefits contained therein. For a full statement of the Standard Terms and the exclusive rights and remedies thereunder, please visit Mini-Circuits' website at [www.minicircuits.com/MCStore/terms.jsp](http://www.minicircuits.com/MCStore/terms.jsp)



# 2 Way 90° Power Splitter/Combiner

# QCH-63B+

## Typical Performance Data

Test Conditions: Input Power =+5 dBm @Temperature = +25°C, Configuration A

Freq. (MHz)	Total Loss <sup>1</sup> (dB)			Amp. Unbal. (dB) (Peak-Peak)	Phase Unbal. (deg) (Rel. to 90°)	Isolation (dB) Port 1 - Port 2	VSWR (:1)			
	Sum-Port 1	Sum-Port 2	Avg				Sum	Port 1	Port 2	Iso
400	1.04	7.47	3.16	6.44	0.93	25.34	1.17	1.17	1.16	1.16
600	1.79	5.17	3.16	3.38	0.86	24.62	1.15	1.14	1.14	1.15
800	2.48	3.94	3.15	1.46	0.82	25.50	1.11	1.09	1.10	1.12
1000	3.04	3.26	3.15	0.22	0.91	27.13	1.07	1.05	1.08	1.11
1050	3.16	3.15	3.15	0.02	0.95	27.56	1.07	1.05	1.07	1.11
1100	3.27	3.05	3.16	0.22	0.99	27.76	1.06	1.05	1.07	1.10
1200	3.45	2.90	3.17	0.55	1.10	27.80	1.07	1.05	1.08	1.10
1300	3.59	2.80	3.18	0.80	1.23	27.16	1.08	1.07	1.10	1.11
1400	3.70	2.73	3.19	0.97	1.39	26.07	1.09	1.09	1.12	1.12
1500	3.78	2.70	3.21	1.08	1.54	24.74	1.11	1.11	1.14	1.13
1600	3.82	2.70	3.22	1.13	1.70	23.46	1.13	1.13	1.16	1.14
1700	3.84	2.72	3.24	1.13	1.83	22.25	1.14	1.15	1.18	1.16
1800	3.84	2.77	3.27	1.08	1.87	21.13	1.16	1.17	1.20	1.17
1900	3.83	2.82	3.30	1.01	1.77	20.23	1.18	1.19	1.21	1.18
2000	3.80	2.89	3.32	0.91	1.56	19.44	1.19	1.20	1.22	1.20
2100	3.76	2.95	3.34	0.82	1.30	18.74	1.20	1.22	1.23	1.22
2200	3.73	3.02	3.36	0.71	0.74	18.16	1.22	1.24	1.24	1.24
2300	3.72	3.08	3.39	0.64	0.16	17.76	1.23	1.26	1.25	1.26
2400	3.73	3.13	3.42	0.60	-0.42	17.50	1.25	1.27	1.26	1.27
2500	3.74	3.15	3.43	0.59	-0.73	17.41	1.26	1.27	1.26	1.28
2600	3.76	3.17	3.45	0.58	-0.88	17.43	1.28	1.28	1.26	1.29
2700	3.77	3.19	3.47	0.57	-0.70	17.55	1.29	1.27	1.26	1.29
2800	3.75	3.22	3.48	0.53	-0.33	17.81	1.31	1.26	1.26	1.28
2900	3.70	3.25	3.47	0.45	0.19	18.24	1.30	1.24	1.25	1.27
3000	3.62	3.31	3.46	0.31	0.62	18.84	1.29	1.21	1.24	1.24
3100	3.52	3.38	3.45	0.14	0.79	19.60	1.27	1.18	1.22	1.22
3200	3.43	3.45	3.44	0.03	0.84	20.59	1.23	1.14	1.18	1.18
3300	3.34	3.52	3.43	0.19	0.67	22.11	1.19	1.10	1.15	1.14
3400	3.25	3.59	3.42	0.34	0.36	24.02	1.15	1.07	1.12	1.10
3500	3.19	3.63	3.40	0.44	0.16	26.86	1.11	1.05	1.11	1.06
3600	3.14	3.68	3.40	0.53	0.03	31.33	1.08	1.04	1.12	1.02
3700	3.10	3.72	3.40	0.62	-0.13	37.45	1.05	1.05	1.15	1.05
3800	3.08	3.78	3.42	0.70	-0.34	33.57	1.02	1.07	1.20	1.10
3900	3.07	3.80	3.42	0.73	-0.38	28.21	1.03	1.09	1.23	1.14
4000	3.10	3.84	3.45	0.74	-0.69	24.76	1.07	1.12	1.27	1.19
4100	3.13	3.86	3.48	0.73	-0.88	22.12	1.10	1.15	1.31	1.24
4200	3.19	3.87	3.52	0.67	-1.27	20.36	1.14	1.18	1.33	1.28
4300	3.32	3.85	3.58	0.54	-1.63	18.84	1.19	1.23	1.34	1.32
4400	3.48	3.82	3.65	0.33	-1.72	17.93	1.25	1.26	1.34	1.35
4500	3.63	3.77	3.70	0.14	-1.47	17.19	1.30	1.31	1.33	1.38
4550	3.71	3.74	3.72	0.04	-1.29	16.94	1.32	1.33	1.33	1.39
4700	3.91	3.66	3.78	0.25	-0.56	16.38	1.39	1.36	1.33	1.43
4800	4.03	3.63	3.83	0.40	-0.27	16.04	1.43	1.37	1.34	1.45
4900	4.13	3.59	3.85	0.54	0.33	15.65	1.46	1.36	1.35	1.47
5000	4.20	3.57	3.87	0.63	0.78	15.60	1.48	1.35	1.35	1.47
5100	4.22	3.54	3.87	0.68	1.31	15.57	1.49	1.32	1.36	1.46
5200	4.18	3.53	3.84	0.64	1.54	15.61	1.48	1.29	1.35	1.46
5300	4.10	3.53	3.81	0.58	1.87	15.68	1.45	1.24	1.32	1.45
5400	3.97	3.55	3.75	0.41	1.72	15.89	1.42	1.19	1.28	1.44
5550	3.75	3.67	3.71	0.08	1.63	16.39	1.37	1.13	1.21	1.37
5800	3.23	4.15	3.67	0.92	0.75	17.81	1.29	1.08	1.15	1.25
6000	2.72	4.98	3.70	2.26	-0.21	18.78	1.21	1.10	1.18	1.12
6200	2.19	6.49	3.83	4.29	-2.30	17.60	1.15	1.18	1.30	1.15
6400	1.75	9.16	4.04	7.40	-6.58	14.94	1.24	1.31	1.46	1.42

Note 1 Total loss is the loss from Sum to each coupled port including the 3dB theoretical split.

**Notes**

- A. Performance and quality attributes and conditions not expressly stated in this specification document are intended to be excluded and do not form a part of this specification document.
- B. Electrical specifications and performance data contained in this specification document are based on Mini-Circuits applicable established test performance criteria and measurement instructions.
- C. The parts covered by this specification document are subject to Mini-Circuits standard limited warranty and terms and conditions (collectively, "Standard Terms"); Purchasers of this part are entitled to the rights and benefits contained therein. For a full statement of the Standard Terms and the exclusive rights and remedies thereunder, please visit Mini-Circuits' website at [www.minicircuits.com/MCStore/terms.jsp](http://www.minicircuits.com/MCStore/terms.jsp)





# 2 Way 90° Power Splitter/Combiner

# QCH-63B+

## Typical Performance Data

Test Conditions: Input Power =+5 dBm @Temperature = +25°C, Configuration B

Freq. (MHz)	Total Loss <sup>1</sup> (dB)			Amp. Unbal. (dB) (Peak-Peak)	Phase Unbal. (deg) (Rel. to 90°)	Isolation (dB) Port 1 - Port 2	VSWR (:1)			
	Sum-Port 1	Sum-Port 2	Avg				Sum	Port 1	Port 2	Iso
400	1.03	7.47	3.15	6.44	0.25	25.34	1.16	1.16	1.17	1.17
600	1.79	5.17	3.16	3.38	-0.17	24.58	1.15	1.14	1.14	1.15
800	2.49	3.94	3.15	1.45	-0.57	25.45	1.12	1.10	1.09	1.11
1000	3.06	3.26	3.16	0.21	-0.76	27.11	1.11	1.08	1.05	1.07
1050	3.17	3.15	3.16	0.02	-0.81	27.50	1.11	1.07	1.05	1.07
1100	3.28	3.05	3.16	0.23	-0.84	27.77	1.10	1.07	1.05	1.06
1200	3.46	2.90	3.17	0.56	-0.90	27.78	1.10	1.08	1.05	1.07
1300	3.60	2.80	3.18	0.81	-0.93	27.13	1.11	1.10	1.07	1.08
1400	3.71	2.73	3.19	0.99	-0.94	26.02	1.12	1.12	1.09	1.09
1500	3.79	2.69	3.21	1.10	-0.92	24.73	1.13	1.14	1.11	1.11
1600	3.84	2.69	3.23	1.15	-0.90	23.46	1.14	1.16	1.13	1.13
1700	3.86	2.71	3.25	1.15	-0.92	22.26	1.16	1.18	1.15	1.14
1800	3.86	2.75	3.27	1.11	-0.97	21.14	1.17	1.20	1.17	1.16
1900	3.84	2.80	3.29	1.04	-1.13	20.22	1.18	1.21	1.19	1.18
2000	3.81	2.87	3.31	0.94	-1.41	19.45	1.20	1.22	1.20	1.19
2100	3.78	2.93	3.33	0.84	-1.84	18.74	1.22	1.23	1.22	1.20
2200	3.75	3.00	3.36	0.75	-2.44	18.15	1.24	1.24	1.24	1.22
2300	3.73	3.05	3.38	0.68	-3.04	17.76	1.26	1.25	1.26	1.23
2400	3.74	3.09	3.40	0.66	-3.63	17.49	1.27	1.26	1.27	1.25
2500	3.75	3.10	3.41	0.66	-3.88	17.39	1.28	1.26	1.27	1.26
2600	3.76	3.12	3.43	0.65	-3.99	17.41	1.29	1.26	1.28	1.28
2700	3.76	3.12	3.43	0.64	-3.75	17.53	1.29	1.26	1.27	1.29
2800	3.74	3.14	3.43	0.60	-3.30	17.80	1.28	1.26	1.26	1.31
2900	3.69	3.17	3.42	0.52	-2.64	18.23	1.27	1.25	1.24	1.30
3000	3.62	3.22	3.42	0.40	-2.13	18.84	1.24	1.24	1.21	1.29
3100	3.53	3.28	3.40	0.25	-1.81	19.61	1.22	1.22	1.18	1.27
3200	3.44	3.35	3.39	0.09	-1.39	20.61	1.18	1.18	1.14	1.23
3300	3.35	3.42	3.38	0.07	-1.33	22.12	1.14	1.15	1.10	1.19
3400	3.27	3.51	3.39	0.24	-1.45	24.04	1.10	1.12	1.07	1.15
3500	3.19	3.57	3.38	0.38	-1.55	26.82	1.06	1.11	1.05	1.11
3600	3.15	3.62	3.38	0.48	-1.67	31.42	1.02	1.12	1.04	1.08
3700	3.13	3.68	3.40	0.55	-1.97	37.47	1.05	1.15	1.05	1.05
3800	3.13	3.72	3.41	0.59	-2.23	33.68	1.10	1.20	1.07	1.02
3900	3.14	3.72	3.42	0.59	-2.20	28.33	1.14	1.23	1.09	1.03
4000	3.17	3.74	3.45	0.57	-2.44	24.80	1.19	1.27	1.12	1.07
4100	3.22	3.74	3.47	0.53	-2.55	22.12	1.24	1.31	1.15	1.10
4200	3.31	3.73	3.51	0.42	-2.82	20.33	1.28	1.33	1.18	1.14
4300	3.42	3.69	3.55	0.27	-3.11	18.80	1.32	1.34	1.23	1.19
4400	3.56	3.62	3.59	0.06	-2.93	17.90	1.35	1.34	1.26	1.25
4500	3.69	3.57	3.63	0.12	-2.62	17.17	1.38	1.33	1.31	1.30
4550	3.74	3.55	3.64	0.20	-2.50	16.88	1.39	1.33	1.33	1.32
4700	3.94	3.48	3.70	0.46	-2.18	16.35	1.43	1.33	1.36	1.39
4800	4.05	3.44	3.73	0.61	-2.13	16.01	1.45	1.34	1.37	1.43
4900	4.11	3.38	3.73	0.72	-1.99	15.63	1.47	1.35	1.36	1.46
5000	4.16	3.32	3.72	0.84	-1.91	15.59	1.47	1.35	1.35	1.48
5100	4.19	3.27	3.71	0.92	-1.53	15.57	1.46	1.36	1.32	1.49
5200	4.18	3.27	3.70	0.91	-1.37	15.61	1.46	1.35	1.29	1.48
5300	4.11	3.29	3.68	0.81	-1.11	15.71	1.45	1.32	1.24	1.45
5400	3.99	3.35	3.66	0.63	-1.30	15.92	1.44	1.28	1.19	1.42
5550	3.76	3.50	3.63	0.25	-1.99	16.43	1.37	1.21	1.13	1.37
5800	3.23	3.98	3.59	0.76	-3.41	17.84	1.25	1.15	1.08	1.29
6000	2.69	4.77	3.61	2.09	-5.12	18.76	1.12	1.18	1.10	1.21
6200	2.20	6.28	3.78	4.08	-7.03	17.57	1.15	1.30	1.18	1.15
6400	1.81	9.05	4.07	7.21	-11.44	14.93	1.42	1.46	1.31	1.24

Note 1 Total loss is the loss from Sum to each coupled port including the 3dB theoretical split.

**Notes**

- A. Performance and quality attributes and conditions not expressly stated in this specification document are intended to be excluded and do not form a part of this specification document.
- B. Electrical specifications and performance data contained in this specification document are based on Mini-Circuits' applicable established test performance criteria and measurement instructions.
- C. The parts covered by this specification document are subject to Mini-Circuits' standard limited warranty and terms and conditions (collectively, "Standard Terms"); Purchasers of this part are entitled to the rights and benefits contained therein. For a full statement of the Standard Terms and the exclusive rights and remedies thereunder, please visit Mini-Circuits' website at [www.minicircuits.com/MCLStore/terms.jsp](http://www.minicircuits.com/MCLStore/terms.jsp)



# 2 Way 90° Power Splitter/Combiner

# QCH-63B+

## Typical Performance Data

Test Conditions: Input Power =+5 dBm @Temperature = +25°C, Configuration C

Freq. (MHz)	Total Loss <sup>1</sup> (dB)			Amp. Unbal. (dB) (Peak-Peak)	Phase Unbal. (deg) (Rel. to 90°)	Isolation (dB) Port 1 - Port 2	VSWR (:1)			
	Sum-Port 1	Sum-Port 2	Avg				Sum	Port 1	Port 2	Iso
400	1.04	7.47	3.16	6.43	0.51	25.77	1.17	1.17	1.16	1.16
600	1.79	5.17	3.16	3.38	0.22	25.60	1.14	1.15	1.15	1.14
800	2.48	3.94	3.15	1.45	-0.05	27.47	1.09	1.11	1.12	1.10
1000	3.05	3.26	3.15	0.22	-0.14	30.08	1.05	1.07	1.11	1.08
1050	3.16	3.15	3.15	0.02	-0.15	30.49	1.05	1.07	1.11	1.07
1100	3.27	3.05	3.16	0.22	-0.17	30.58	1.05	1.06	1.10	1.07
1200	3.45	2.90	3.17	0.55	-0.16	29.70	1.05	1.07	1.10	1.08
1300	3.59	2.80	3.18	0.79	-0.13	27.78	1.07	1.08	1.11	1.10
1400	3.70	2.73	3.19	0.97	-0.08	25.85	1.09	1.09	1.12	1.12
1500	3.78	2.69	3.20	1.08	-0.02	24.01	1.11	1.11	1.13	1.14
1600	3.82	2.69	3.22	1.14	0.04	22.55	1.13	1.13	1.14	1.16
1700	3.85	2.71	3.24	1.14	0.08	21.34	1.15	1.14	1.16	1.18
1800	3.84	2.75	3.26	1.10	0.09	20.31	1.17	1.16	1.17	1.20
1900	3.83	2.80	3.28	1.03	-0.03	19.52	1.19	1.18	1.18	1.21
2000	3.80	2.87	3.31	0.93	-0.24	18.84	1.20	1.19	1.20	1.22
2100	3.76	2.93	3.33	0.83	-0.59	18.26	1.22	1.20	1.22	1.23
2200	3.73	3.00	3.35	0.74	-1.18	17.86	1.24	1.22	1.24	1.24
2300	3.72	3.05	3.37	0.67	-1.72	17.68	1.26	1.23	1.26	1.25
2400	3.73	3.09	3.40	0.64	-2.27	17.63	1.27	1.25	1.27	1.26
2500	3.74	3.10	3.41	0.64	-2.48	17.66	1.27	1.26	1.28	1.26
2600	3.76	3.11	3.42	0.64	-2.54	17.85	1.28	1.28	1.29	1.26
2700	3.77	3.12	3.43	0.64	-2.23	18.22	1.27	1.29	1.29	1.26
2800	3.75	3.14	3.43	0.60	-1.61	18.73	1.26	1.31	1.28	1.26
2900	3.69	3.17	3.42	0.52	-0.88	19.43	1.24	1.30	1.27	1.25
3000	3.62	3.22	3.42	0.40	-0.27	20.20	1.21	1.29	1.24	1.24
3100	3.52	3.28	3.40	0.24	0.10	21.13	1.18	1.27	1.22	1.22
3200	3.43	3.35	3.39	0.08	0.53	22.42	1.14	1.23	1.18	1.18
3300	3.34	3.42	3.38	0.08	0.71	23.85	1.10	1.19	1.14	1.15
3400	3.25	3.51	3.38	0.26	0.65	25.70	1.07	1.15	1.10	1.12
3500	3.20	3.57	3.38	0.37	0.62	27.10	1.05	1.11	1.06	1.11
3600	3.14	3.62	3.37	0.48	0.70	27.19	1.04	1.08	1.02	1.12
3700	3.10	3.68	3.38	0.58	0.56	26.14	1.05	1.05	1.05	1.15
3800	3.08	3.72	3.39	0.64	0.39	24.64	1.07	1.02	1.10	1.20
3900	3.07	3.73	3.39	0.65	0.38	23.09	1.09	1.03	1.14	1.23
4000	3.10	3.74	3.41	0.64	0.11	21.88	1.12	1.07	1.19	1.27
4100	3.12	3.74	3.42	0.61	-0.04	20.67	1.15	1.10	1.24	1.31
4200	3.19	3.72	3.45	0.53	-0.40	19.77	1.18	1.14	1.28	1.33
4300	3.32	3.69	3.50	0.37	-0.87	19.09	1.23	1.19	1.32	1.34
4400	3.48	3.62	3.55	0.14	-0.83	18.74	1.26	1.25	1.35	1.34
4500	3.63	3.57	3.60	0.07	-0.52	18.56	1.31	1.30	1.38	1.33
4550	3.70	3.54	3.62	0.16	-0.38	18.48	1.33	1.32	1.39	1.33
4700	3.91	3.48	3.69	0.44	0.13	18.67	1.36	1.39	1.43	1.33
4800	4.04	3.44	3.73	0.59	0.15	18.75	1.37	1.43	1.45	1.34
4900	4.13	3.38	3.74	0.75	0.44	19.00	1.36	1.46	1.47	1.35
5000	4.20	3.32	3.74	0.88	0.69	19.34	1.35	1.48	1.47	1.35
5100	4.22	3.27	3.72	0.95	1.40	19.68	1.32	1.49	1.46	1.36
5200	4.18	3.27	3.70	0.91	1.63	20.38	1.29	1.48	1.46	1.35
5300	4.10	3.29	3.68	0.81	1.86	21.12	1.24	1.45	1.45	1.32
5400	3.96	3.35	3.64	0.62	1.77	22.04	1.19	1.42	1.44	1.28
5550	3.75	3.50	3.62	0.25	1.14	22.96	1.13	1.37	1.37	1.21
5800	3.22	3.98	3.58	0.75	-0.15	24.10	1.08	1.29	1.25	1.15
6000	2.72	4.78	3.63	2.05	-1.43	21.92	1.10	1.21	1.12	1.18
6200	2.19	6.28	3.77	4.09	-3.26	18.85	1.18	1.15	1.15	1.30
6400	1.75	9.03	4.02	7.30	-7.50	16.08	1.31	1.24	1.42	1.46

Note 1 Total loss is the loss from Sum to each coupled port including the 3dB theoretical split.

Notes

- A. Performance and quality attributes and conditions not expressly stated in this specification document are intended to be excluded and do not form a part of this specification document.
- B. Electrical specifications and performance data contained in this specification document are based on Mini-Circuits' applicable established test performance criteria and measurement instructions.
- C. The parts covered by this specification document are subject to Mini-Circuits' standard limited warranty and terms and conditions (collectively, "Standard Terms"); Purchasers of this part are entitled to the rights and benefits contained therein. For a full statement of the Standard Terms and the exclusive rights and remedies thereunder, please visit Mini-Circuits' website at [www.minicircuits.com/MQLStore/terms.jsp](http://www.minicircuits.com/MQLStore/terms.jsp)



# 2 Way 90° Power Splitter/Combiner

# QCH-63B+

## Typical Performance Data

Test Conditions: Input Power = +5 dBm @ Temperature = +25°C, Configuration D

Freq. (MHz)	Total Loss <sup>1</sup> (dB)			Amp. Unbal. (dB) (Peak-Peak)	Phase Unbal. (deg) (Rel. to 90°)	Isolation (dB) Port 1 - Port 2	VSWR (:1)			
	Sum-Port 1	Sum-Port 2	Avg				Sum	Port 1	Port 2	Iso
400	1.03	7.47	3.15	6.44	0.69	25.78	1.16	1.16	1.17	1.17
600	1.79	5.17	3.16	3.38	0.46	25.64	1.14	1.15	1.15	1.14
800	2.49	3.94	3.15	1.45	0.28	27.47	1.10	1.12	1.11	1.09
1000	3.05	3.26	3.15	0.21	0.29	30.07	1.08	1.11	1.07	1.05
1050	3.17	3.15	3.16	0.03	0.29	30.51	1.07	1.11	1.07	1.05
1100	3.28	3.05	3.16	0.23	0.33	30.62	1.07	1.10	1.06	1.05
1200	3.46	2.90	3.17	0.56	0.37	29.71	1.08	1.10	1.07	1.05
1300	3.60	2.79	3.18	0.81	0.45	27.81	1.10	1.11	1.08	1.07
1400	3.71	2.73	3.19	0.98	0.55	25.86	1.12	1.12	1.09	1.09
1500	3.79	2.70	3.21	1.09	0.64	24.01	1.14	1.13	1.11	1.11
1600	3.84	2.69	3.23	1.14	0.75	22.55	1.16	1.14	1.13	1.13
1700	3.86	2.72	3.25	1.14	0.83	21.34	1.18	1.16	1.14	1.15
1800	3.86	2.76	3.28	1.09	0.82	20.30	1.20	1.17	1.16	1.17
1900	3.84	2.82	3.30	1.02	0.68	19.50	1.21	1.18	1.18	1.19
2000	3.81	2.88	3.32	0.93	0.40	18.82	1.22	1.20	1.19	1.20
2100	3.77	2.95	3.34	0.83	0.06	18.25	1.23	1.22	1.20	1.22
2200	3.75	3.02	3.37	0.73	-0.54	17.85	1.24	1.24	1.22	1.24
2300	3.73	3.08	3.39	0.65	-1.16	17.67	1.25	1.26	1.23	1.26
2400	3.74	3.13	3.42	0.62	-1.82	17.62	1.26	1.27	1.25	1.27
2500	3.75	3.15	3.44	0.60	-2.14	17.65	1.26	1.28	1.26	1.27
2600	3.76	3.17	3.45	0.60	-2.31	17.85	1.26	1.29	1.28	1.28
2700	3.76	3.20	3.47	0.57	-2.21	18.22	1.26	1.29	1.29	1.27
2800	3.74	3.22	3.47	0.52	-2.01	18.73	1.26	1.28	1.31	1.26
2900	3.69	3.25	3.46	0.44	-1.57	19.43	1.25	1.27	1.30	1.24
3000	3.62	3.31	3.46	0.31	-1.27	20.20	1.24	1.24	1.29	1.21
3100	3.53	3.38	3.45	0.15	-1.12	21.12	1.22	1.22	1.27	1.18
3200	3.44	3.45	3.44	0.01	-1.09	22.40	1.18	1.18	1.23	1.14
3300	3.35	3.52	3.43	0.17	-1.35	23.85	1.15	1.14	1.19	1.10
3400	3.27	3.59	3.43	0.32	-1.75	25.65	1.12	1.10	1.15	1.07
3500	3.19	3.64	3.41	0.45	-2.02	27.10	1.11	1.06	1.11	1.05
3600	3.14	3.67	3.40	0.53	-2.33	27.18	1.12	1.02	1.08	1.04
3700	3.13	3.72	3.41	0.60	-2.64	26.14	1.15	1.05	1.05	1.05
3800	3.13	3.78	3.44	0.65	-2.96	24.67	1.20	1.10	1.02	1.07
3900	3.13	3.80	3.45	0.66	-2.97	23.11	1.23	1.14	1.03	1.09
4000	3.17	3.84	3.49	0.67	-3.26	21.89	1.27	1.19	1.07	1.12
4100	3.22	3.85	3.52	0.64	-3.42	20.64	1.31	1.24	1.10	1.15
4200	3.30	3.87	3.58	0.56	-3.67	19.73	1.33	1.28	1.14	1.18
4300	3.42	3.86	3.63	0.43	-3.88	19.06	1.34	1.32	1.19	1.23
4400	3.56	3.82	3.69	0.26	-3.83	18.74	1.34	1.35	1.25	1.26
4500	3.68	3.77	3.72	0.08	-3.61	18.56	1.33	1.38	1.30	1.31
4550	3.74	3.74	3.74	0.00	-3.46	18.46	1.33	1.39	1.32	1.33
4700	3.94	3.66	3.80	0.28	-2.94	18.66	1.33	1.43	1.39	1.36
4800	4.05	3.63	3.83	0.42	-2.61	18.75	1.34	1.45	1.43	1.37
4900	4.10	3.59	3.84	0.52	-2.16	18.99	1.35	1.47	1.46	1.36
5000	4.16	3.57	3.85	0.60	-1.89	19.33	1.35	1.47	1.48	1.35
5100	4.19	3.54	3.85	0.65	-1.68	19.66	1.36	1.46	1.49	1.32
5200	4.18	3.53	3.84	0.65	-1.53	20.35	1.35	1.46	1.48	1.29
5300	4.11	3.53	3.81	0.58	-1.17	21.13	1.32	1.45	1.45	1.24
5400	3.99	3.55	3.76	0.44	-1.39	22.04	1.28	1.44	1.42	1.19
5550	3.76	3.67	3.71	0.09	-1.52	22.92	1.21	1.37	1.37	1.13
5800	3.22	4.14	3.66	0.92	-2.46	24.01	1.15	1.25	1.29	1.08
6000	2.69	4.98	3.69	2.29	-3.78	21.79	1.18	1.12	1.21	1.10
6200	2.20	6.48	3.83	4.29	-5.91	18.78	1.30	1.15	1.15	1.18
6400	1.82	9.15	4.09	7.35	-10.40	16.07	1.46	1.42	1.24	1.31

Note 1 Total loss is the loss from Sum to each coupled port including the 3dB theoretical split.

**Notes**

- A. Performance and quality attributes and conditions not expressly stated in this specification document are intended to be excluded and do not form a part of this specification document.
- B. Electrical specifications and performance data contained in this specification document are based on Mini-Circuits' applicable established test performance criteria and measurement instructions.
- C. The parts covered by this specification document are subject to Mini-Circuits' standard limited warranty and terms and conditions (collectively, "Standard Terms"); Purchasers of this part are entitled to the rights and benefits contained therein. For a full statement of the Standard Terms and the exclusive rights and remedies thereunder, please visit Mini-Circuits' website at [www.minicircuits.com/MCULStore/terms.jsp](http://www.minicircuits.com/MCULStore/terms.jsp)



# 2 Way 90° Power Splitter/Combiner

# QCH-63B+

## Typical Performance Data

Test Conditions: Input Power = +5 dBm @ Temperature = +105°C, Configuration A

Freq. (MHz)	Total Loss <sup>1</sup> (dB)			Amp. Unbal. (dB) (Peak-Peak)	Phase Unbal. (deg) (Rel. to 90°)	Isolation (dB) Port 1 - Port 2	VSWR (:1)			
	Sum-Port 1	Sum-Port 2	Avg				Sum	Port 1	Port 2	Iso
400	1.03	7.52	3.16	6.49	0.83	25.54	1.18	1.18	1.17	1.17
600	1.77	5.20	3.15	3.43	0.67	25.37	1.14	1.13	1.13	1.14
800	2.46	3.96	3.15	1.50	0.61	26.60	1.09	1.07	1.08	1.10
1000	3.02	3.28	3.15	0.26	0.69	28.48	1.06	1.04	1.06	1.09
1050	3.14	3.16	3.15	0.02	0.74	28.88	1.06	1.04	1.06	1.09
1100	3.24	3.07	3.15	0.18	0.80	28.80	1.06	1.05	1.06	1.09
1200	3.42	2.92	3.16	0.51	0.92	28.21	1.06	1.06	1.08	1.10
1300	3.57	2.81	3.17	0.76	1.05	26.92	1.08	1.09	1.10	1.11
1400	3.68	2.75	3.19	0.93	1.18	25.43	1.10	1.10	1.13	1.13
1500	3.75	2.72	3.20	1.04	1.37	23.93	1.11	1.12	1.15	1.14
1600	3.79	2.71	3.22	1.08	1.53	22.63	1.13	1.14	1.17	1.16
1700	3.81	2.74	3.24	1.07	1.62	21.58	1.15	1.15	1.19	1.17
1800	3.80	2.78	3.26	1.02	1.62	20.69	1.16	1.17	1.20	1.18
1900	3.77	2.83	3.27	0.94	1.44	19.92	1.18	1.18	1.21	1.19
2000	3.74	2.89	3.29	0.85	1.13	19.28	1.19	1.20	1.22	1.21
2100	3.71	2.94	3.31	0.76	0.73	18.71	1.21	1.21	1.22	1.22
2200	3.68	3.00	3.33	0.68	0.21	18.28	1.22	1.23	1.23	1.24
2300	3.67	3.04	3.34	0.63	-0.31	17.94	1.24	1.25	1.24	1.26
2400	3.67	3.07	3.36	0.59	-0.76	17.78	1.25	1.26	1.24	1.27
2500	3.67	3.10	3.38	0.57	-1.01	17.71	1.26	1.27	1.25	1.28
2600	3.67	3.12	3.39	0.55	-1.10	17.76	1.27	1.26	1.25	1.28
2700	3.67	3.16	3.41	0.51	-1.04	17.94	1.29	1.26	1.25	1.27
2800	3.65	3.18	3.41	0.47	-0.81	18.26	1.29	1.24	1.25	1.26
2900	3.60	3.21	3.40	0.39	-0.43	18.70	1.29	1.23	1.25	1.25
3000	3.53	3.25	3.39	0.28	-0.09	19.35	1.27	1.20	1.24	1.23
3100	3.45	3.32	3.38	0.13	0.25	20.11	1.25	1.17	1.21	1.21
3200	3.36	3.39	3.37	0.03	0.36	21.18	1.22	1.14	1.19	1.18
3300	3.27	3.46	3.36	0.19	0.39	22.58	1.19	1.11	1.17	1.14
3400	3.18	3.54	3.36	0.36	0.27	24.38	1.15	1.08	1.14	1.10
3500	3.12	3.60	3.35	0.49	0.05	27.03	1.12	1.06	1.12	1.06
3600	3.07	3.66	3.35	0.58	-0.14	30.97	1.08	1.04	1.12	1.02
3700	3.03	3.71	3.36	0.68	-0.25	35.23	1.05	1.05	1.14	1.04
3800	3.00	3.76	3.36	0.75	-0.38	32.45	1.01	1.06	1.17	1.09
3900	3.00	3.80	3.38	0.79	-0.63	27.85	1.02	1.09	1.21	1.15
4000	3.00	3.82	3.39	0.82	-0.86	24.54	1.05	1.12	1.26	1.20
4100	3.03	3.83	3.41	0.79	-1.09	22.16	1.09	1.15	1.29	1.25
4200	3.10	3.83	3.45	0.72	-1.57	20.41	1.13	1.19	1.32	1.29
4300	3.20	3.79	3.48	0.60	-2.05	19.12	1.17	1.22	1.33	1.31
4400	3.31	3.73	3.51	0.41	-2.39	18.07	1.21	1.26	1.32	1.33
4500	3.46	3.65	3.55	0.19	-2.76	17.30	1.26	1.29	1.32	1.35
4550	3.55	3.61	3.58	0.05	-2.74	16.92	1.29	1.31	1.32	1.36
4700	3.83	3.46	3.64	0.37	-2.22	16.18	1.38	1.34	1.33	1.39
4800	3.99	3.39	3.68	0.59	-1.60	15.89	1.43	1.36	1.35	1.42
4900	4.10	3.33	3.70	0.77	-0.84	15.69	1.47	1.35	1.36	1.44
5000	4.16	3.29	3.70	0.86	0.06	15.55	1.48	1.33	1.36	1.47
5100	4.22	3.32	3.75	0.89	0.73	15.61	1.48	1.30	1.35	1.48
5200	4.16	3.33	3.73	0.83	1.15	15.66	1.47	1.27	1.33	1.49
5300	4.10	3.37	3.72	0.73	1.53	15.87	1.44	1.24	1.29	1.47
5400	3.94	3.43	3.68	0.50	1.66	16.08	1.40	1.19	1.25	1.44
5550	3.69	3.63	3.66	0.06	1.06	16.46	1.36	1.13	1.18	1.38
5800	3.18	4.17	3.65	0.98	-0.47	17.90	1.26	1.11	1.15	1.23
6000	2.70	5.03	3.71	2.32	-1.89	18.85	1.18	1.15	1.23	1.08
6200	2.18	6.57	3.84	4.39	-3.84	17.22	1.15	1.23	1.35	1.15
6400	1.77	9.08	4.04	7.31	-8.30	14.25	1.25	1.31	1.43	1.38

Note 1 Total loss is the loss from Sum to each coupled port including the 3dB theoretical split.

**Notes**

- A. Performance and quality attributes and conditions not expressly stated in this specification document are intended to be excluded and do not form a part of this specification document.
- B. Electrical specifications and performance data contained in this specification document are based on Mini-Circuits applicable established test performance criteria and measurement instructions.
- C. The parts covered by this specification document are subject to Mini-Circuits standard limited warranty and terms and conditions (collectively, "Standard Terms"); Purchasers of this part are entitled to the rights and benefits contained therein. For a full statement of the Standard Terms and the exclusive rights and remedies thereunder, please visit Mini-Circuits' website at [www.minicircuits.com/MCLStore/terms.jsp](http://www.minicircuits.com/MCLStore/terms.jsp)



# 2 Way 90° Power Splitter/Combiner

# QCH-63B+

## Typical Performance Data

Test Conditions: Input Power = +5 dBm @ Temperature = +105°C, Configuration B

Freq. (MHz)	Total Loss <sup>1</sup> (dB)			Amp. Unbal. (dB) (Peak-Peak)	Phase Unbal. (deg) (Rel. to 90°)	Isolation (dB) Port 1 - Port 2	VSWR (:1)			
	Sum-Port 1	Sum-Port 2	Avg				Sum	Port 1	Port 2	Iso
400	1.02	7.51	3.15	6.49	0.26	25.52	1.17	1.17	1.18	1.18
600	1.77	5.19	3.15	3.42	-0.18	25.33	1.14	1.13	1.13	1.14
800	2.46	3.95	3.14	1.49	-0.53	26.56	1.10	1.08	1.07	1.09
1000	3.03	3.27	3.15	0.24	-0.67	28.46	1.09	1.06	1.04	1.06
1050	3.14	3.16	3.15	0.01	-0.70	28.80	1.09	1.06	1.04	1.06
1100	3.25	3.06	3.15	0.19	-0.73	28.77	1.09	1.06	1.05	1.06
1200	3.43	2.91	3.16	0.52	-0.76	28.21	1.10	1.08	1.06	1.06
1300	3.58	2.80	3.17	0.77	-0.77	26.92	1.11	1.10	1.09	1.08
1400	3.69	2.74	3.19	0.95	-0.73	25.44	1.13	1.13	1.10	1.10
1500	3.77	2.70	3.20	1.06	-0.66	23.94	1.14	1.15	1.12	1.11
1600	3.81	2.70	3.22	1.11	-0.60	22.67	1.16	1.17	1.14	1.13
1700	3.83	2.72	3.24	1.11	-0.58	21.63	1.17	1.19	1.15	1.15
1800	3.82	2.76	3.26	1.06	-0.63	20.70	1.18	1.20	1.17	1.16
1900	3.79	2.81	3.27	0.98	-0.79	19.94	1.19	1.21	1.18	1.18
2000	3.75	2.87	3.29	0.89	-1.08	19.29	1.21	1.22	1.20	1.19
2100	3.72	2.93	3.31	0.79	-1.52	18.70	1.22	1.22	1.21	1.21
2200	3.69	2.99	3.33	0.70	-2.05	18.29	1.24	1.23	1.23	1.22
2300	3.68	3.04	3.35	0.64	-2.55	17.94	1.26	1.24	1.25	1.24
2400	3.67	3.07	3.36	0.60	-3.02	17.77	1.27	1.24	1.26	1.25
2500	3.67	3.09	3.37	0.58	-3.30	17.68	1.28	1.25	1.27	1.26
2600	3.66	3.11	3.38	0.56	-3.34	17.73	1.28	1.25	1.26	1.27
2700	3.66	3.12	3.38	0.54	-3.19	17.91	1.27	1.25	1.26	1.29
2800	3.64	3.15	3.39	0.50	-2.84	18.25	1.26	1.25	1.24	1.29
2900	3.59	3.18	3.38	0.42	-2.36	18.72	1.25	1.25	1.23	1.29
3000	3.53	3.22	3.37	0.31	-1.93	19.35	1.23	1.24	1.20	1.27
3100	3.44	3.28	3.36	0.16	-1.59	20.10	1.21	1.21	1.17	1.25
3200	3.36	3.35	3.35	0.01	-1.28	21.17	1.18	1.19	1.14	1.22
3300	3.28	3.42	3.35	0.14	-1.06	22.57	1.14	1.17	1.11	1.19
3400	3.20	3.51	3.35	0.31	-1.04	24.39	1.10	1.14	1.08	1.15
3500	3.13	3.57	3.34	0.44	-1.09	27.08	1.06	1.12	1.06	1.12
3600	3.08	3.63	3.35	0.55	-1.14	31.00	1.02	1.12	1.04	1.08
3700	3.04	3.70	3.36	0.66	-1.20	35.30	1.04	1.14	1.05	1.05
3800	3.04	3.75	3.38	0.71	-1.36	32.49	1.09	1.17	1.06	1.01
3900	3.06	3.78	3.41	0.73	-1.47	27.92	1.15	1.21	1.09	1.02
4000	3.09	3.82	3.44	0.74	-1.59	24.58	1.20	1.26	1.12	1.05
4100	3.13	3.84	3.47	0.71	-1.75	22.18	1.25	1.29	1.15	1.09
4200	3.20	3.82	3.50	0.63	-2.13	20.39	1.29	1.32	1.19	1.13
4300	3.29	3.77	3.52	0.48	-2.31	19.10	1.31	1.33	1.22	1.17
4400	3.39	3.72	3.55	0.33	-2.54	18.05	1.33	1.32	1.26	1.21
4500	3.52	3.63	3.57	0.12	-2.80	17.25	1.35	1.32	1.29	1.26
4550	3.59	3.59	3.59	0.00	-2.82	16.88	1.36	1.32	1.31	1.29
4700	3.82	3.44	3.63	0.38	-2.76	16.12	1.39	1.33	1.34	1.38
4800	3.97	3.35	3.65	0.61	-2.18	15.81	1.42	1.35	1.36	1.43
4900	4.08	3.29	3.67	0.78	-1.64	15.64	1.44	1.36	1.35	1.47
5000	4.16	3.25	3.68	0.90	-0.99	15.50	1.47	1.36	1.33	1.48
5100	4.22	3.27	3.72	0.93	-0.38	15.60	1.48	1.35	1.30	1.48
5200	4.18	3.31	3.72	0.86	0.01	15.65	1.49	1.33	1.27	1.47
5300	4.12	3.37	3.73	0.75	0.05	15.84	1.47	1.29	1.24	1.44
5400	3.98	3.44	3.70	0.53	-0.12	16.06	1.44	1.25	1.19	1.40
5550	3.73	3.62	3.67	0.12	-1.02	16.43	1.38	1.18	1.13	1.36
5800	3.18	4.09	3.61	0.90	-3.19	17.83	1.23	1.15	1.11	1.26
6000	2.70	4.92	3.67	2.21	-5.16	18.75	1.08	1.23	1.15	1.18
6200	2.20	6.42	3.82	4.21	-7.76	17.15	1.15	1.35	1.23	1.15
6400	1.83	9.05	4.09	7.22	-12.34	14.25	1.38	1.43	1.31	1.25

Note 1 Total loss is the loss from Sum to each coupled port including the 3dB theoretical split.

**Notes**

- A. Performance and quality attributes and conditions not expressly stated in this specification document are intended to be excluded and do not form a part of this specification document.
- B. Electrical specifications and performance data contained in this specification document are based on Mini-Circuits applicable established test performance criteria and measurement instructions.
- C. The parts covered by this specification document are subject to Mini-Circuits standard limited warranty and terms and conditions (collectively, "Standard Terms"); Purchasers of this part are entitled to the rights and benefits contained therein. For a full statement of the Standard Terms and the exclusive rights and remedies thereunder, please visit Mini-Circuits' website at [www.minicircuits.com/MCLStore/terms.jsp](http://www.minicircuits.com/MCLStore/terms.jsp)



# 2 Way 90° Power Splitter/Combiner

# QCH-63B+

## Typical Performance Data

Test Conditions: Input Power = +5 dBm @ Temperature = +105°C, Configuration C

Freq. (MHz)	Total Loss <sup>1</sup> (dB)			Amp. Unbal. (dB) (Peak-Peak)	Phase Unbal. (deg) (Rel. to 90°)	Isolation (dB) Port 1 - Port 2	VSWR (:1)			
	Sum-Port 1	Sum-Port 2	Avg				Sum	Port 1	Port 2	Iso
400	1.03	7.51	3.16	6.48	0.41	26.06	1.18	1.18	1.17	1.17
600	1.77	5.19	3.15	3.42	0.05	26.08	1.13	1.14	1.14	1.13
800	2.46	3.95	3.14	1.48	-0.21	28.47	1.07	1.09	1.10	1.08
1000	3.02	3.27	3.14	0.25	-0.30	31.58	1.04	1.06	1.09	1.06
1050	3.14	3.16	3.15	0.02	-0.31	31.79	1.04	1.06	1.09	1.06
1100	3.25	3.06	3.15	0.19	-0.32	31.21	1.05	1.06	1.09	1.06
1200	3.43	2.91	3.16	0.52	-0.31	29.38	1.06	1.06	1.10	1.08
1300	3.57	2.81	3.17	0.77	-0.27	27.13	1.09	1.08	1.11	1.10
1400	3.68	2.74	3.18	0.94	-0.22	25.17	1.10	1.10	1.13	1.13
1500	3.75	2.70	3.19	1.05	-0.12	23.51	1.12	1.11	1.14	1.15
1600	3.79	2.70	3.21	1.10	-0.04	22.21	1.14	1.13	1.16	1.17
1700	3.81	2.72	3.23	1.09	-0.01	21.16	1.15	1.15	1.17	1.19
1800	3.80	2.76	3.25	1.04	-0.04	20.27	1.17	1.16	1.18	1.20
1900	3.77	2.80	3.26	0.97	-0.19	19.57	1.18	1.18	1.19	1.21
2000	3.74	2.87	3.28	0.88	-0.48	19.00	1.20	1.19	1.21	1.22
2100	3.71	2.93	3.30	0.78	-0.88	18.56	1.21	1.21	1.22	1.22
2200	3.68	2.99	3.32	0.70	-1.36	18.22	1.23	1.22	1.24	1.23
2300	3.67	3.04	3.34	0.63	-1.86	18.01	1.25	1.24	1.26	1.24
2400	3.67	3.07	3.36	0.60	-2.31	17.98	1.26	1.25	1.27	1.24
2500	3.67	3.09	3.37	0.58	-2.53	18.03	1.27	1.26	1.28	1.25
2600	3.68	3.11	3.39	0.57	-2.53	18.20	1.26	1.27	1.28	1.25
2700	3.68	3.12	3.39	0.55	-2.30	18.52	1.26	1.29	1.27	1.25
2800	3.65	3.15	3.39	0.50	-1.89	18.98	1.24	1.29	1.26	1.25
2900	3.61	3.18	3.39	0.42	-1.30	19.56	1.23	1.29	1.25	1.25
3000	3.54	3.22	3.38	0.31	-0.82	20.26	1.20	1.27	1.23	1.24
3100	3.45	3.29	3.37	0.17	-0.39	21.04	1.17	1.25	1.21	1.21
3200	3.37	3.35	3.36	0.01	0.00	22.17	1.14	1.22	1.18	1.19
3300	3.27	3.42	3.34	0.15	0.24	23.45	1.11	1.19	1.14	1.17
3400	3.18	3.51	3.34	0.33	0.27	24.82	1.08	1.15	1.10	1.14
3500	3.12	3.57	3.34	0.45	0.26	26.05	1.06	1.12	1.06	1.12
3600	3.08	3.63	3.35	0.56	0.30	26.78	1.04	1.08	1.02	1.12
3700	3.03	3.70	3.35	0.67	0.32	26.21	1.05	1.05	1.04	1.14
3800	3.01	3.75	3.36	0.74	0.31	25.00	1.06	1.01	1.09	1.17
3900	3.00	3.79	3.38	0.79	0.20	23.41	1.09	1.02	1.15	1.21
4000	3.00	3.83	3.40	0.83	0.02	21.87	1.12	1.05	1.20	1.26
4100	3.04	3.84	3.42	0.81	-0.30	20.61	1.15	1.09	1.25	1.29
4200	3.11	3.83	3.46	0.72	-0.81	19.59	1.19	1.13	1.29	1.32
4300	3.20	3.77	3.48	0.58	-1.17	18.88	1.22	1.17	1.31	1.33
4400	3.32	3.72	3.52	0.41	-1.50	18.33	1.26	1.21	1.33	1.32
4500	3.47	3.63	3.55	0.17	-1.84	18.04	1.29	1.26	1.35	1.32
4550	3.56	3.59	3.57	0.04	-1.82	17.90	1.31	1.29	1.36	1.32
4700	3.83	3.44	3.63	0.39	-1.64	17.88	1.34	1.38	1.39	1.33
4800	3.99	3.36	3.66	0.64	-0.91	18.19	1.36	1.43	1.42	1.35
4900	4.11	3.30	3.69	0.81	-0.13	18.82	1.35	1.47	1.44	1.36
5000	4.17	3.26	3.69	0.91	0.63	19.43	1.33	1.48	1.47	1.36
5100	4.22	3.28	3.72	0.95	1.32	20.23	1.30	1.48	1.48	1.35
5200	4.17	3.32	3.72	0.85	1.66	21.04	1.27	1.47	1.49	1.33
5300	4.11	3.37	3.72	0.74	1.84	22.00	1.24	1.44	1.47	1.29
5400	3.94	3.44	3.68	0.50	1.69	22.68	1.19	1.40	1.44	1.25
5550	3.69	3.61	3.65	0.07	0.57	23.30	1.13	1.36	1.38	1.18
5800	3.19	4.09	3.62	0.91	-1.42	22.73	1.11	1.26	1.23	1.15
6000	2.70	4.93	3.67	2.23	-3.20	20.19	1.15	1.18	1.08	1.23
6200	2.17	6.42	3.79	4.24	-5.79	17.45	1.23	1.15	1.15	1.35
6400	1.77	9.06	4.04	7.28	-10.37	15.55	1.31	1.25	1.38	1.43

Note 1 Total loss is the loss from Sum to each coupled port including the 3dB theoretical split.

**Notes**

- A. Performance and quality attributes and conditions not expressly stated in this specification document are intended to be excluded and do not form a part of this specification document.
- B. Electrical specifications and performance data contained in this specification document are based on Mini-Circuits applicable established test performance criteria and measurement instructions.
- C. The parts covered by this specification document are subject to Mini-Circuits standard limited warranty and terms and conditions (collectively, "Standard Terms"); Purchasers of this part are entitled to the rights and benefits contained therein. For a full statement of the Standard Terms and the exclusive rights and remedies thereunder, please visit Mini-Circuits' website at [www.minicircuits.com/MCLStore/terms.jsp](http://www.minicircuits.com/MCLStore/terms.jsp)





# 2 Way 90° Power Splitter/Combiner

# QCH-63B+

## Typical Performance Data

Test Conditions: Input Power = +5 dBm @ Temperature = +105°C, Configuration D

Freq. (MHz)	Total Loss <sup>1</sup> (dB)			Amp. Unbal. (dB) (Peak-Peak)	Phase Unbal. (deg) (Rel. to 90°)	Isolation (dB) Port 1 - Port 2	VSWR (:1)			
	Sum-Port 1	Sum-Port 2	Avg				Sum	Port 1	Port 2	Iso
400	1.02	7.52	3.15	6.50	0.68	26.06	1.17	1.17	1.18	1.18
600	1.77	5.20	3.15	3.43	0.43	26.11	1.13	1.14	1.14	1.13
800	2.46	3.96	3.15	1.50	0.29	28.48	1.08	1.10	1.09	1.07
1000	3.03	3.28	3.15	0.25	0.32	31.53	1.06	1.09	1.06	1.04
1050	3.14	3.17	3.15	0.02	0.36	31.79	1.06	1.09	1.06	1.04
1100	3.25	3.07	3.16	0.18	0.39	31.14	1.06	1.09	1.06	1.05
1200	3.43	2.92	3.17	0.51	0.46	29.30	1.08	1.10	1.06	1.06
1300	3.58	2.81	3.18	0.76	0.55	27.16	1.10	1.11	1.08	1.09
1400	3.69	2.75	3.19	0.94	0.68	25.21	1.13	1.13	1.10	1.10
1500	3.77	2.72	3.21	1.05	0.83	23.55	1.15	1.14	1.11	1.12
1600	3.81	2.71	3.23	1.10	0.97	22.23	1.17	1.16	1.13	1.14
1700	3.82	2.74	3.25	1.09	1.05	21.15	1.19	1.17	1.15	1.15
1800	3.82	2.78	3.27	1.04	1.02	20.26	1.20	1.18	1.16	1.17
1900	3.79	2.83	3.28	0.96	0.86	19.57	1.21	1.19	1.18	1.18
2000	3.75	2.89	3.30	0.87	0.53	19.01	1.22	1.21	1.19	1.20
2100	3.72	2.95	3.32	0.78	0.07	18.55	1.22	1.22	1.21	1.21
2200	3.69	3.00	3.33	0.69	-0.48	18.21	1.23	1.24	1.22	1.23
2300	3.68	3.04	3.35	0.64	-1.00	17.99	1.24	1.26	1.24	1.25
2400	3.67	3.08	3.36	0.59	-1.47	17.98	1.24	1.27	1.25	1.26
2500	3.67	3.10	3.38	0.57	-1.80	18.04	1.25	1.28	1.26	1.27
2600	3.67	3.13	3.39	0.54	-1.93	18.20	1.25	1.28	1.27	1.26
2700	3.67	3.16	3.41	0.51	-1.93	18.54	1.25	1.27	1.29	1.26
2800	3.65	3.19	3.41	0.46	-1.79	18.98	1.25	1.26	1.29	1.24
2900	3.60	3.21	3.40	0.39	-1.50	19.59	1.25	1.25	1.29	1.23
3000	3.53	3.26	3.39	0.27	-1.20	20.28	1.24	1.23	1.27	1.20
3100	3.45	3.32	3.38	0.13	-0.97	21.03	1.21	1.21	1.25	1.17
3200	3.37	3.39	3.38	0.03	-0.93	22.13	1.19	1.18	1.22	1.14
3300	3.28	3.46	3.37	0.18	-0.90	23.39	1.17	1.14	1.19	1.11
3400	3.20	3.54	3.37	0.34	-1.05	24.74	1.14	1.10	1.15	1.08
3500	3.13	3.61	3.36	0.47	-1.32	25.97	1.12	1.06	1.12	1.06
3600	3.08	3.65	3.36	0.58	-1.59	26.65	1.12	1.02	1.08	1.04
3700	3.04	3.71	3.36	0.67	-1.79	26.08	1.14	1.04	1.05	1.05
3800	3.04	3.76	3.39	0.73	-2.08	24.83	1.17	1.09	1.01	1.06
3900	3.06	3.80	3.41	0.74	-2.32	23.26	1.21	1.15	1.02	1.09
4000	3.08	3.82	3.43	0.73	-2.46	21.76	1.26	1.20	1.05	1.12
4100	3.13	3.83	3.47	0.70	-2.54	20.53	1.29	1.25	1.09	1.15
4200	3.20	3.83	3.50	0.63	-2.88	19.57	1.32	1.29	1.13	1.19
4300	3.29	3.80	3.54	0.51	-3.16	18.87	1.33	1.31	1.17	1.22
4400	3.39	3.73	3.56	0.34	-3.40	18.34	1.32	1.33	1.21	1.26
4500	3.52	3.65	3.58	0.13	-3.65	18.06	1.32	1.35	1.26	1.29
4550	3.60	3.61	3.60	0.02	-3.69	17.92	1.32	1.36	1.29	1.31
4700	3.82	3.46	3.64	0.36	-3.30	17.91	1.33	1.39	1.38	1.34
4800	3.97	3.40	3.68	0.58	-2.83	18.22	1.35	1.42	1.43	1.36
4900	4.08	3.34	3.69	0.76	-2.32	18.80	1.36	1.44	1.47	1.35
5000	4.16	3.30	3.71	0.87	-1.49	19.41	1.36	1.47	1.48	1.33
5100	4.21	3.33	3.75	0.90	-0.98	20.17	1.35	1.48	1.48	1.30
5200	4.18	3.34	3.74	0.85	-0.52	20.99	1.33	1.49	1.47	1.27
5300	4.12	3.38	3.73	0.75	-0.29	21.93	1.29	1.47	1.44	1.24
5400	3.98	3.43	3.70	0.55	-0.14	22.62	1.25	1.44	1.40	1.19
5550	3.73	3.64	3.68	0.10	-0.50	23.20	1.18	1.38	1.36	1.13
5800	3.19	4.16	3.65	0.99	-2.28	22.65	1.15	1.23	1.26	1.11
6000	2.71	5.02	3.71	2.32	-3.89	20.11	1.23	1.08	1.18	1.15
6200	2.21	6.57	3.86	4.37	-5.93	17.41	1.35	1.15	1.15	1.23
6400	1.84	9.09	4.10	7.24	-10.35	15.54	1.43	1.38	1.25	1.31

Note 1 Total loss is the loss from Sum to each coupled port including the 3dB theoretical split.

**Notes**

- A. Performance and quality attributes and conditions not expressly stated in this specification document are intended to be excluded and do not form a part of this specification document.
- B. Electrical specifications and performance data contained in this specification document are based on Mini-Circuits applicable established test performance criteria and measurement instructions.
- C. The parts covered by this specification document are subject to Mini-Circuits standard limited warranty and terms and conditions (collectively, "Standard Terms"); Purchasers of this part are entitled to the rights and benefits contained therein. For a full statement of the Standard Terms and the exclusive rights and remedies thereunder, please visit Mini-Circuits' website at [www.minicircuits.com/MCLStore/terms.jsp](http://www.minicircuits.com/MCLStore/terms.jsp)



# 2 Way 90° Power Splitter/Combiner

# QCH-63B+

## Typical Performance Curves (Configuration A)

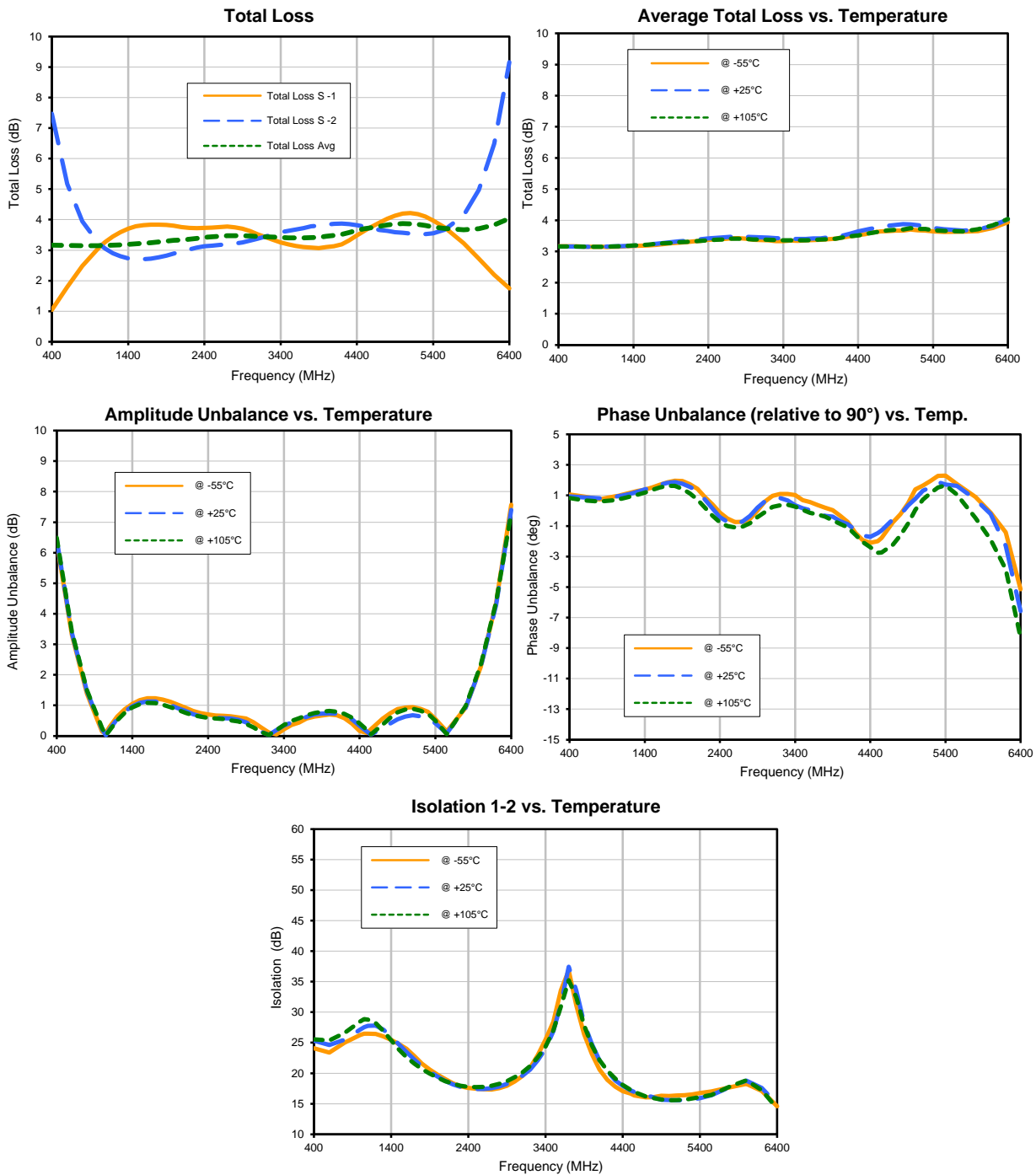

### Notes

- A. Performance and quality attributes and conditions not expressly stated in this specification document are intended to be excluded and do not form a part of this specification document.
- B. Electrical specifications and performance data contained in this specification document are based on Mini-Circuits' applicable established test performance criteria and measurement instructions.
- C. The parts covered by this specification document are subject to Mini-Circuits' standard limited warranty and terms and conditions (collectively, "Standard Terms"); Purchasers of this part are entitled to the rights and benefits contained therein. For a full statement of the Standard Terms and the exclusive rights and remedies thereunder, please visit Mini-Circuits' website at [www.minicircuits.com/MCLStore/terms.jsp](http://www.minicircuits.com/MCLStore/terms.jsp)



# 2 Way 90° Power Splitter/Combiner

# QCH-63B+

## Typical Performance Curves (Configuration B)

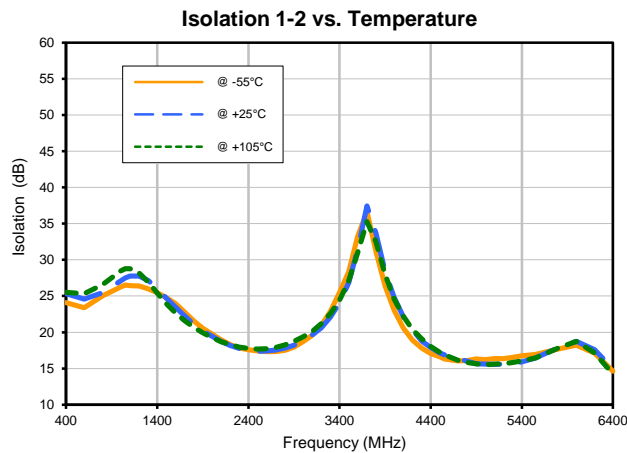
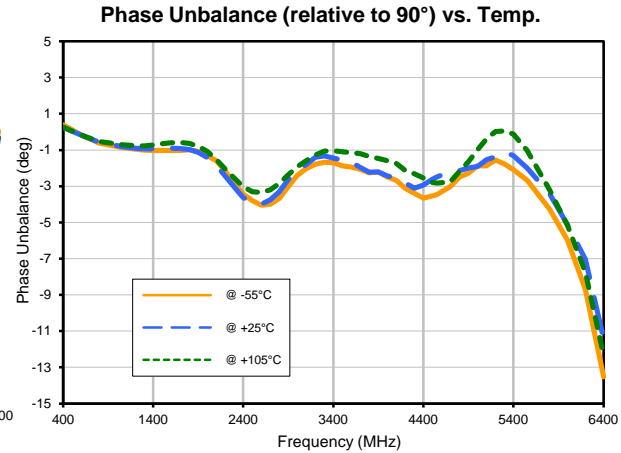
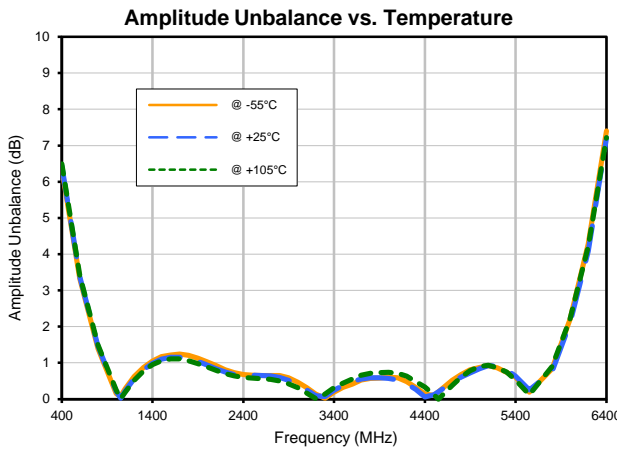
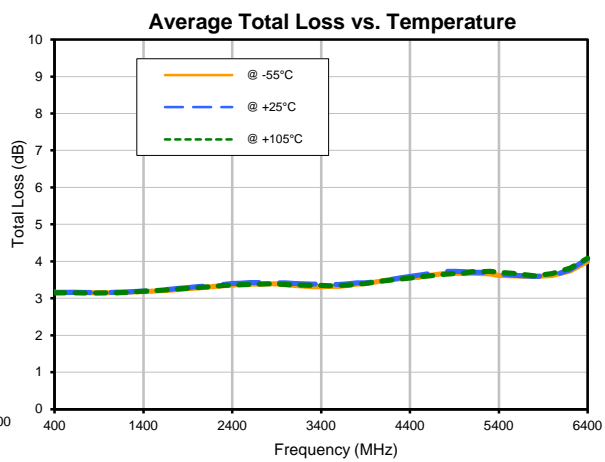
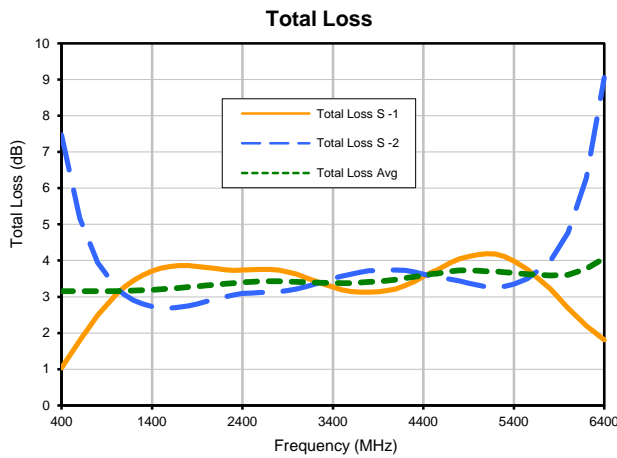

### Notes

- A. Performance and quality attributes and conditions not expressly stated in this specification document are intended to be excluded and do not form a part of this specification document.
- B. Electrical specifications and performance data contained in this specification document are based on Mini-Circuits' applicable established test performance criteria and measurement instructions.
- C. The parts covered by this specification document are subject to Mini-Circuits' standard limited warranty and terms and conditions (collectively, "Standard Terms"); Purchasers of this part are entitled to the rights and benefits contained therein. For a full statement of the Standard Terms and the exclusive rights and remedies thereunder, please visit Mini-Circuits' website at [www.minicircuits.com/MCLStore/terms.jsp](http://www.minicircuits.com/MCLStore/terms.jsp)



# 2 Way 90° Power Splitter/Combiner

# QCH-63B+

## Typical Performance Curves (Configuration C)

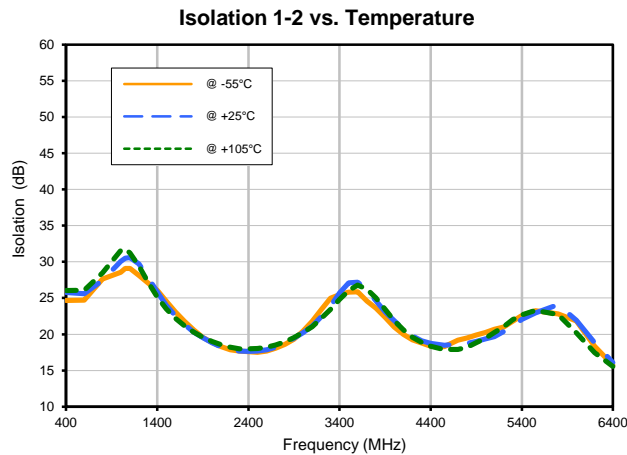
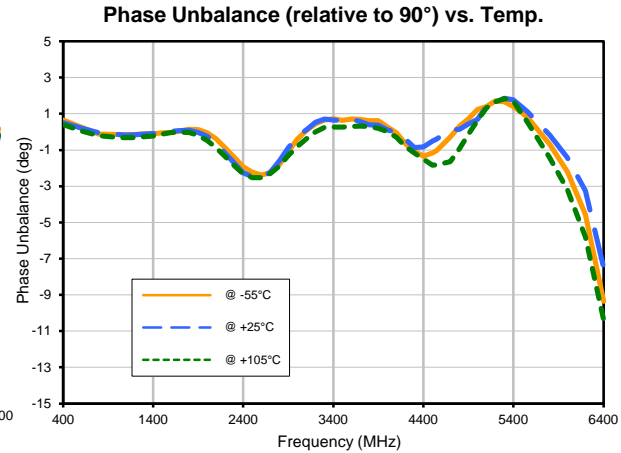
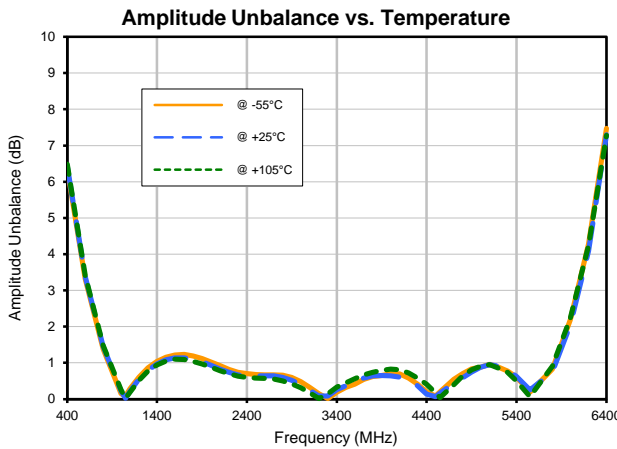
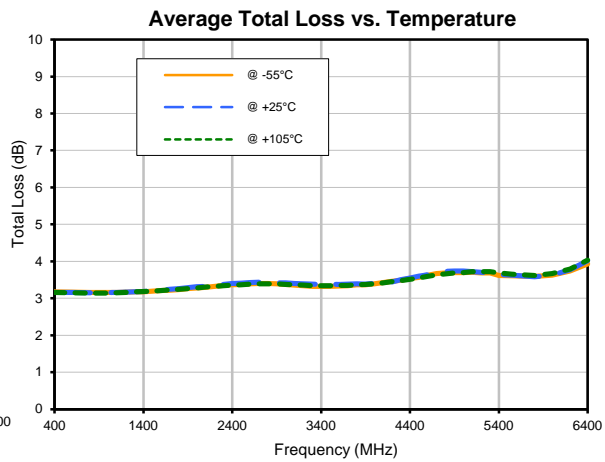
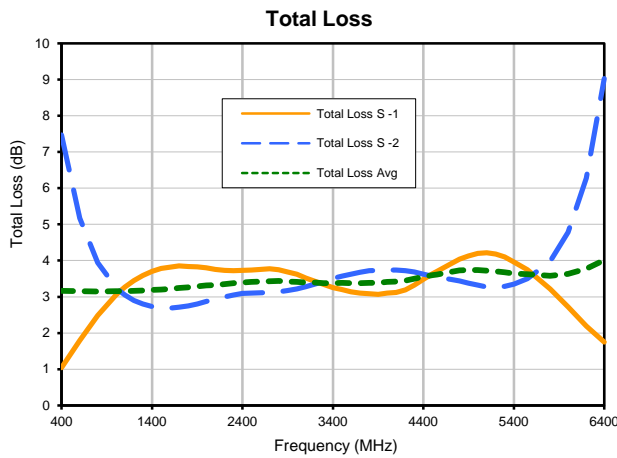

### Notes

- A. Performance and quality attributes and conditions not expressly stated in this specification document are intended to be excluded and do not form a part of this specification document.
- B. Electrical specifications and performance data contained in this specification document are based on Mini-Circuits' applicable established test performance criteria and measurement instructions.
- C. The parts covered by this specification document are subject to Mini-Circuits' standard limited warranty and terms and conditions (collectively, "Standard Terms"); Purchasers of this part are entitled to the rights and benefits contained therein. For a full statement of the Standard Terms and the exclusive rights and remedies thereunder, please visit Mini-Circuits' website at [www.minicircuits.com/MCLStore/terms.jsp](http://www.minicircuits.com/MCLStore/terms.jsp)



# 2 Way 90° Power Splitter/Combiner

# QCH-63B+

## Typical Performance Curves (Configuration D)

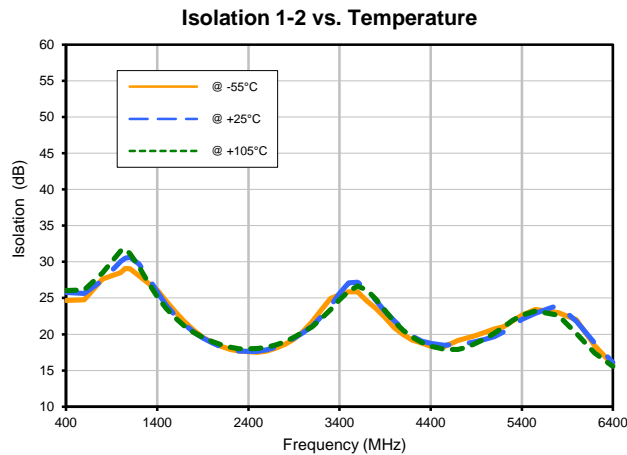
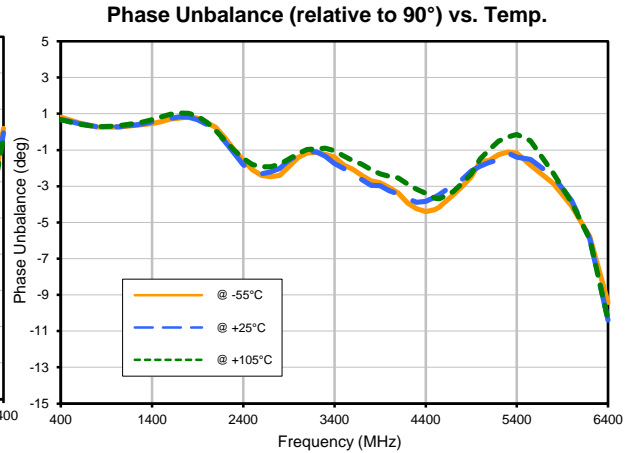
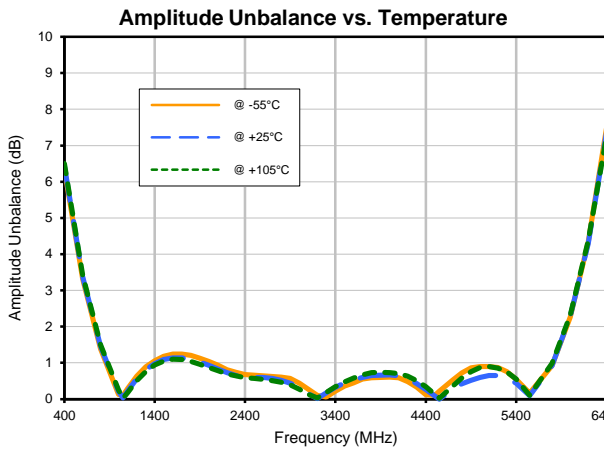
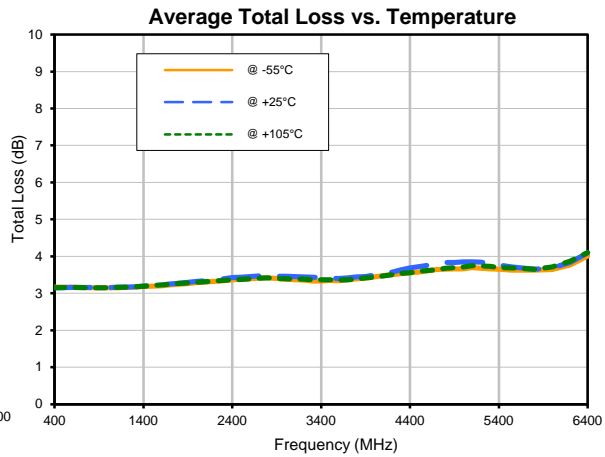
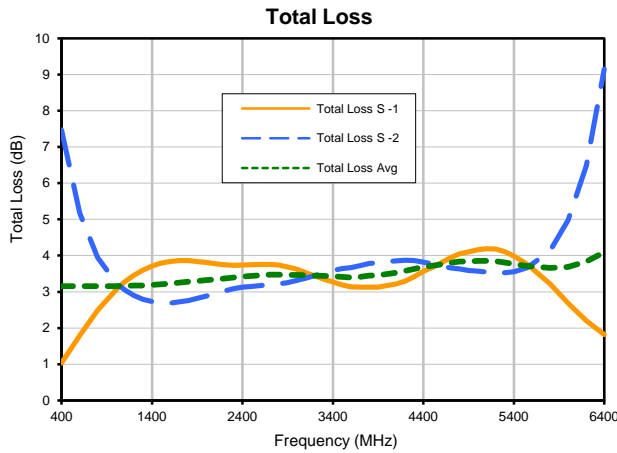

### Notes

- A. Performance and quality attributes and conditions not expressly stated in this specification document are intended to be excluded and do not form a part of this specification document.
- B. Electrical specifications and performance data contained in this specification document are based on Mini-Circuits' applicable established test performance criteria and measurement instructions.
- C. The parts covered by this specification document are subject to Mini-Circuits' standard limited warranty and terms and conditions (collectively, "Standard Terms"); Purchasers of this part are entitled to the rights and benefits contained therein. For a full statement of the Standard Terms and the exclusive rights and remedies thereunder, please visit Mini-Circuits' website at [www.minicircuits.com/MCLStore/terms.jsp](http://www.minicircuits.com/MCLStore/terms.jsp)



# 2 Way 90° Power Splitter/Combiner

# QCH-63B+

## Typical Performance Curves (VSWR at Configuration A)

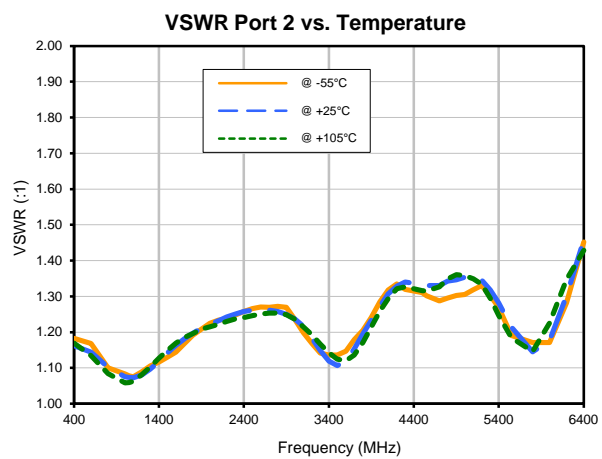
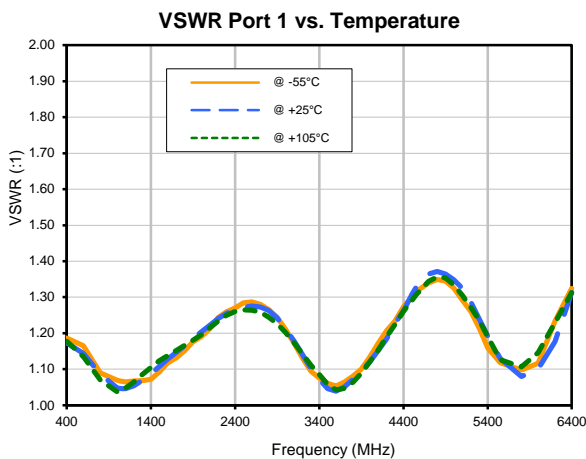
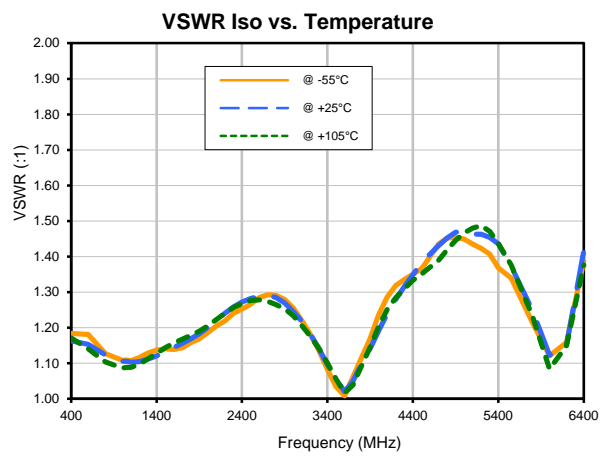
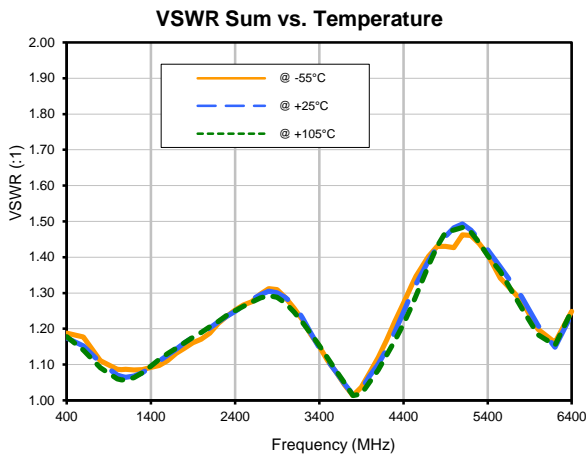
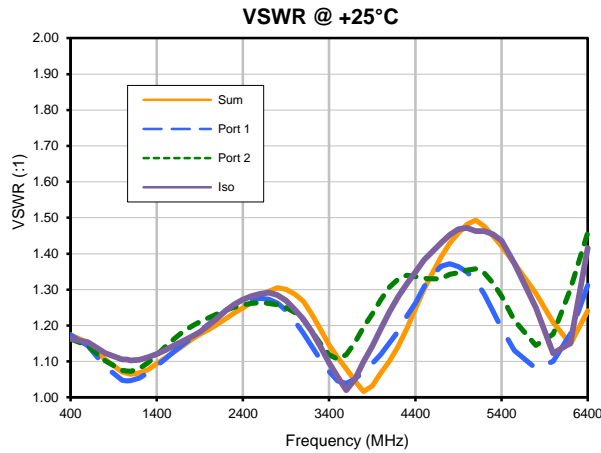

### Notes

- A. Performance and quality attributes and conditions not expressly stated in this specification document are intended to be excluded and do not form a part of this specification document.
- B. Electrical specifications and performance data contained in this specification document are based on Mini-Circuits' applicable established test performance criteria and measurement instructions.
- C. The parts covered by this specification document are subject to Mini-Circuits' standard limited warranty and terms and conditions (collectively, "Standard Terms"). Purchasers of this part are entitled to the rights and benefits contained therein. For a full statement of the Standard Terms and the exclusive rights and remedies thereunder, please visit Mini-Circuits' website at [www.minicircuits.com/MCLStore/terms.jsp](http://www.minicircuits.com/MCLStore/terms.jsp)





# Case Style

# PQ

## Outline Dimensions

## PQ2181

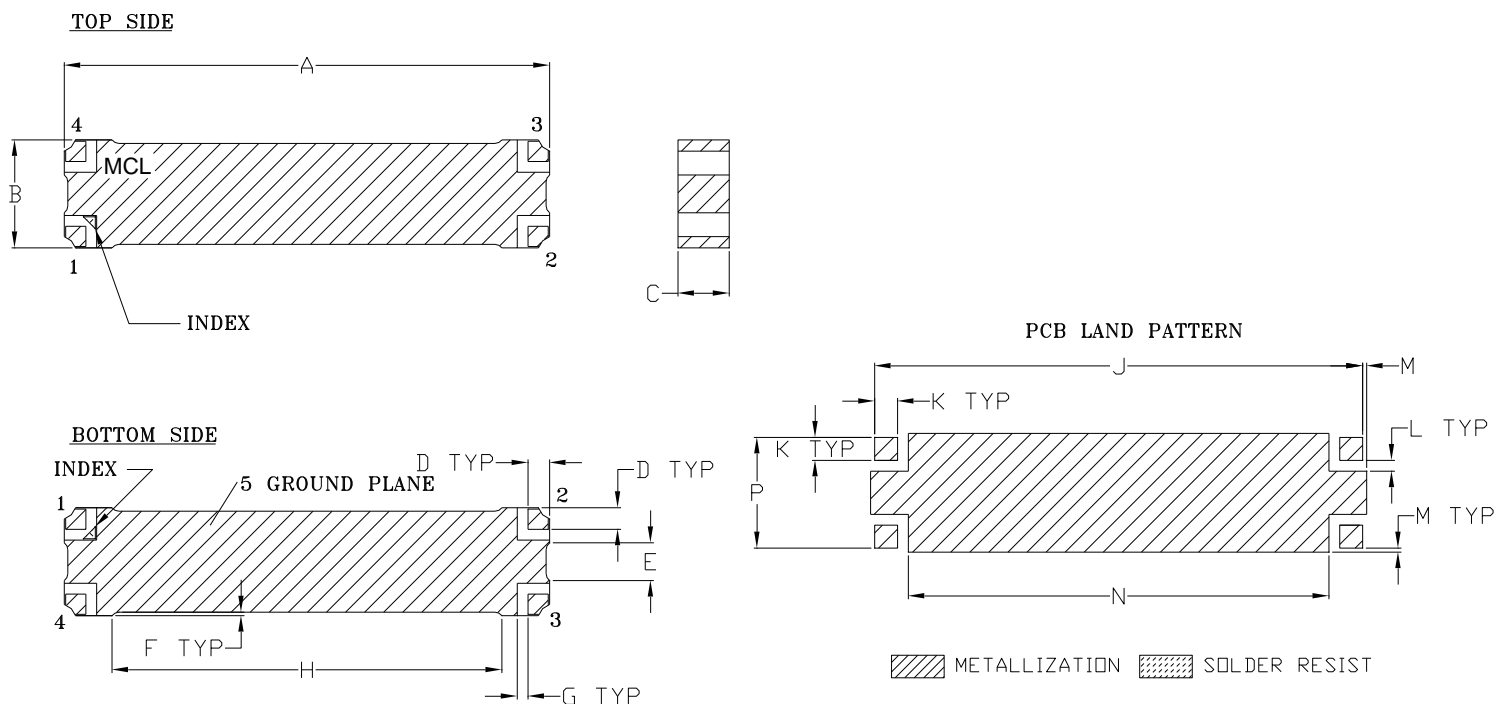

CASE#	A	B	C	D	E	F	G	H	J	K	L	M	N	P	WT. GRAMS
PQ2181	1.800 (45.72)	.400 (10.16)	.190 (4.83)	.080 (2.03)	.140 (3.56)	.013 (0.33)	.040 (1.02)	1.446 (36.73)	1.810 (45.97)	.085 (2.16)	.040 (1.02)	.015 (0.38)	1.560 (39.62)	.410 (10.41)	1.0

Dimensions are in inches (mm). Tolerances: 2PL. +/- .03; 3PL. +/- .010

### Notes:

1. Base material: Printed wiring laminate.
2. Termination finish:  
 For RoHS Cases, all models (+) suffix: 2-5  $\mu$ inch (.05-.13 microns) Immersion Gold.  
 For RoHS-5 Cases, all models no (+) suffix: Tin-Lead plate.

**Mini-Circuits**<sup>®</sup>

INTERNET <http://www.minicircuits.com>

P.O. Box 350166, Brooklyn, New York 11235-0003 (718) 934-4500 Fax (718) 332-4661

Distribution Centers NORTH AMERICA 800-654-7949 • 417-335-5935 • Fax 417-335-5945 • EUROPE 44-1252-832600 • Fax 44-1252-837010

Mini-Circuits ISO 9001 & ISO 14001 Certified

# Tape & Reel Packaging TR-F120

## DEVICE ORIENTATION IN T&R

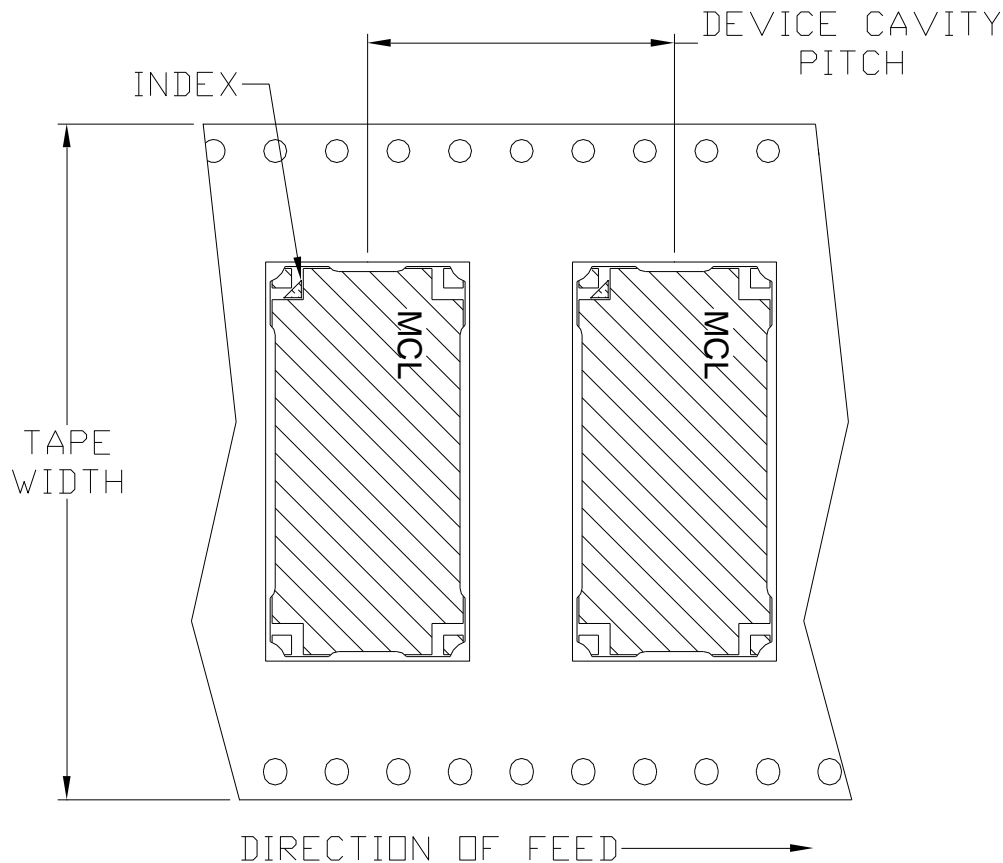

Tape Width, mm	Device Cavity Pitch, mm	Reel Size, inches	Devices per Reel	
72	16	13	Small quantity standards (see note)	20
				50
				100
				200
			Standard	500

Note: Please consult individual model data sheet to determine device per reel availability.

Mini-Circuits carrier tape materials provide protection from ESD (Electro-Static Discharge) during handling and transportation. Tapes are static dissipative and comply with industry standards EIA-481/EIA-541.

Go to: [www.minicircuits.com/pages/pdfs/tape.pdf](http://www.minicircuits.com/pages/pdfs/tape.pdf)

**Mini-Circuits**<sup>®</sup>

INTERNET <http://www.minicircuits.com>

P.O. Box 350166, Brooklyn, New York 11235-0003 (718) 934-4500 Fax (718) 332-4661

Distribution Centers NORTH AMERICA 800-654-7949 • 417-335-5935 • Fax 417-335-5945 • EUROPE 44-1252-832600 • Fax 44-1252-837010

Mini-Circuits ISO 9001 & ISO 14001 Certified

THIRD ANGLE PROJECTION

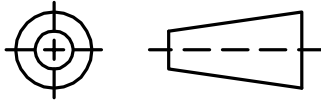

REVISIONS

REV	ECN No.	DESCRIPTION	DATE	DR	AUTH
OR	M165053	NEW RELEASE (FROM RAVON)	12/17	DK	HH
OR	R92774	NEW RELEASE (FROM RAVON)	12/17	DK	HH

**SUGGESTED MOUNTING CONFIGURATION  
FOR PQ2181 CASE STYLE 08DC08 PIN CONNECTION, 50 OHM**

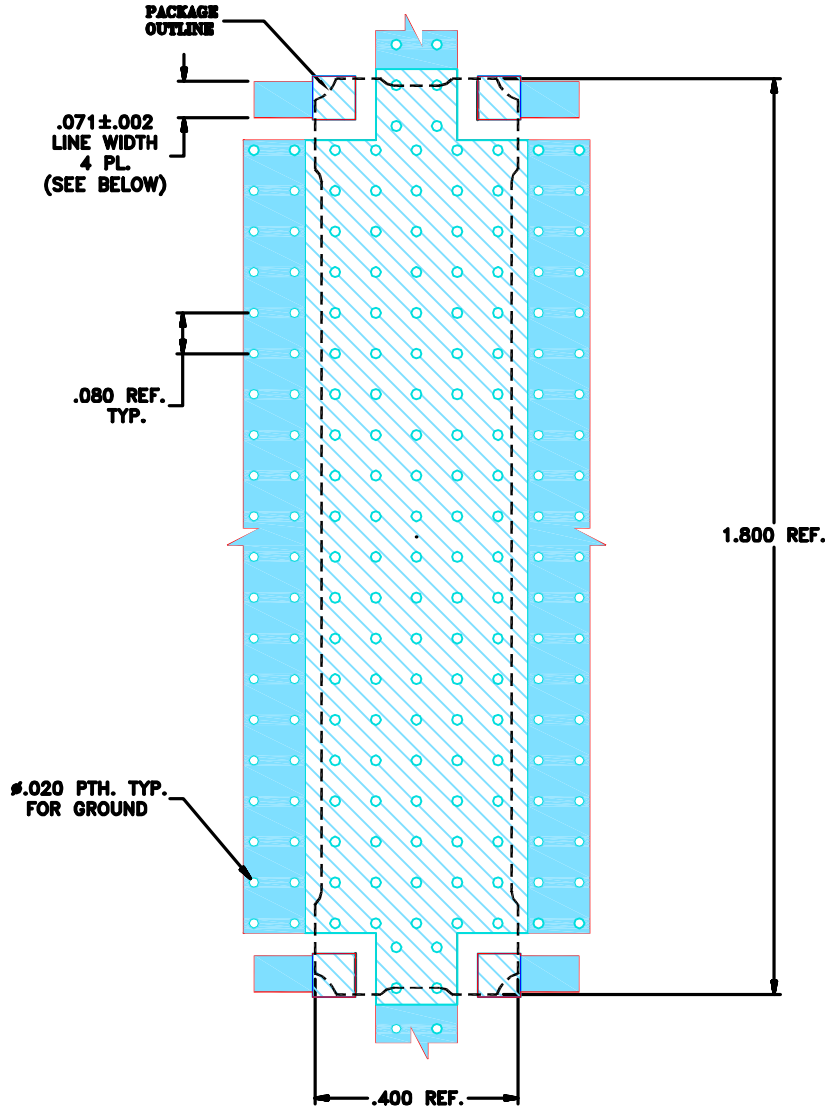

NOTES:

- TRACE WIDTH IS SHOWN FOR ROGERS R04003C WITH DIELECTRIC THICKNESS.  $.032 \pm .003$ ". COPPER: 1 OZ. EACH SIDE. FOR OTHER MATERIALS TRACE WIDTH MAY NEED TO BE MODIFIED.
- BOTTOM SIDE OF THE PCB IS CONTINUOUS GROUND PLANE.

DENOTES PCB COPPER LAYOUT WITH SMOBC (SOLDER MASK OVER BARE COPPER)

DENOTES COPPER LAND PATTERN FREE OF SOLDERMASK

UNLESS OTHERWISE SPECIFIED

INITIALS      DATE

DIMENSIONS ARE IN INCHES  
TOLERANCES ON:  
2 PL DECIMALS ±  
3 PL DECIMALS ± .005  
ANGLES ±  
FRACTIONS ±

DRAWN	DK (RAVON)	03 DEC 17
CHECKED	RM (RAVON)	03 DEC 17
APPROVED	HH (RAVON)	03 DEC 17



**Mini-Circuits®** 13 Neptune Avenue  
Brooklyn NY 11235

**PL, 08DC08, PQ2181  
TB-884+**

Mini-Circuits®  
THIS DOCUMENT AND ITS CONTENTS ARE THE PROPERTY OF MINI-CIRCUITS. EXCEPT FOR USE EXPRESSLY GRANTED, IN WRITING, TO ITS VENDORS, VENDEE AND THE UNITED STATES GOVERNMENT, MINI-CIRCUITS RESERVES ALL PROPRIETARY DESIGN, USE, MANUFACTURING AND REPRODUCTION RIGHTS THERETO. THESE CONTENTS SHALL NOT BE USED, DUPLICATED OR DISCLOSED TO ANY OUTSIDE PARTY, IN WHOLE OR IN PART, WITHOUT WRITTEN PERMISSION OF MINI-CIRCUITS.

SIZE	CODE IDENT	DRAWING NO:	REV:
A	15542	98-PL-539	OR

FILE:	SCALE:	SHEET:
98PL539(OR)	2.5:1	1 OF 1

# Evaluation Board and Circuit

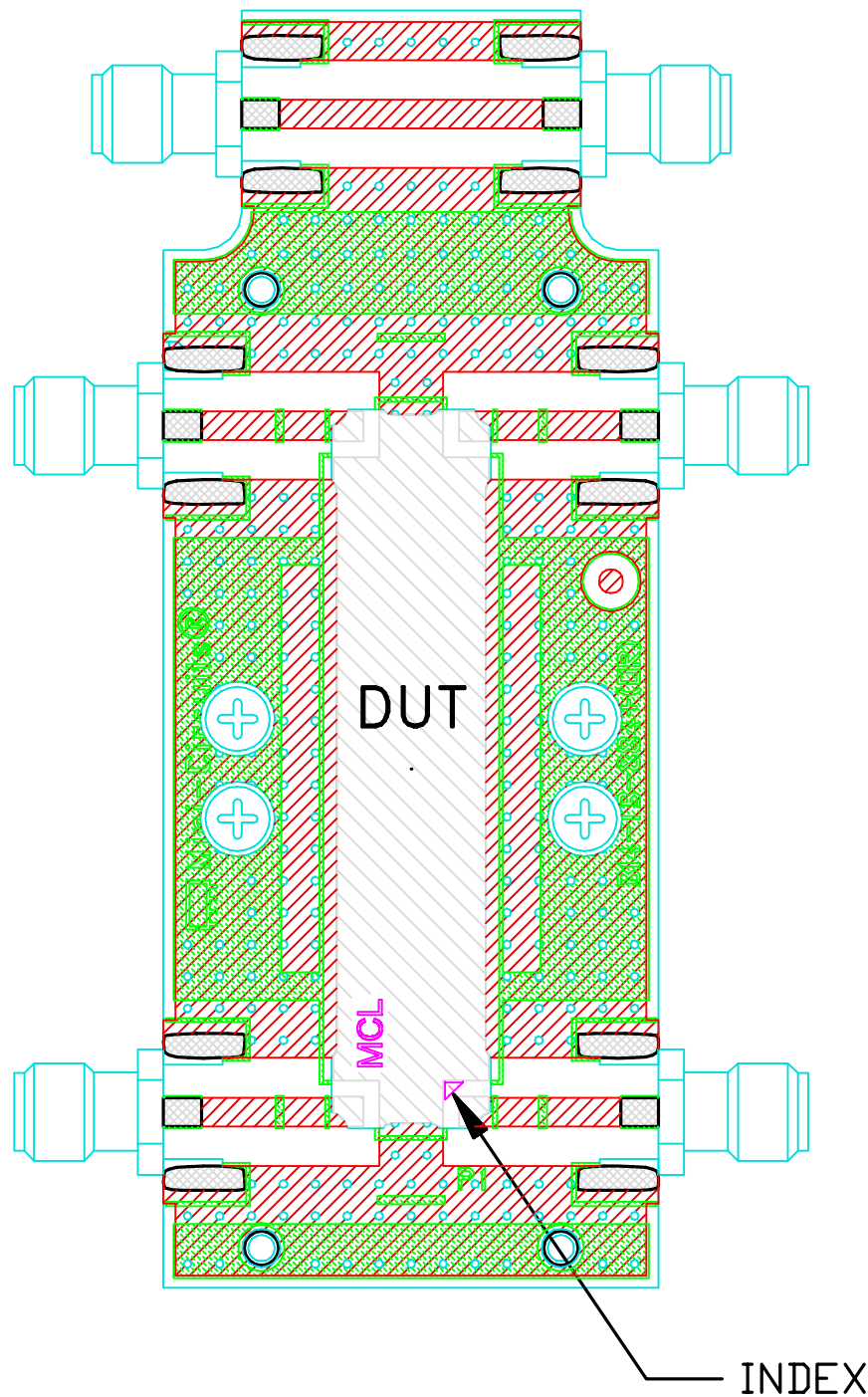

TB-998+

## NOTES:

1. SMA F JACK CONNECTORS.
2. PCB MATERIAL: ROGERS R04003C OR EQUIVALENT, DIALECTRIC CONSTANT=3.5, DIALECTRIC THICKNESS=.032 INCH.

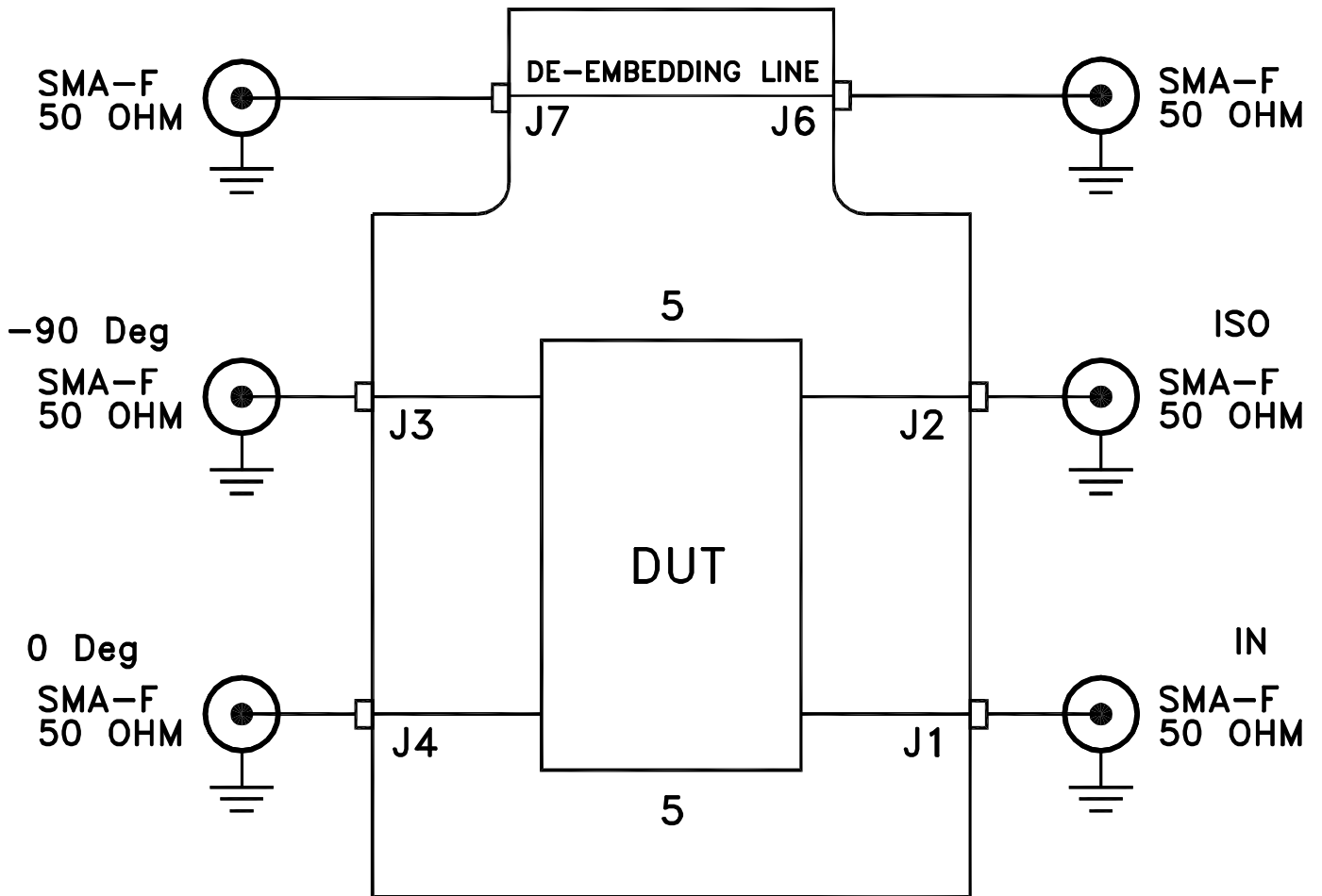

TB-998+  
Schematic Diagram



All Mini-Circuits products are manufactured under exacting quality assurance and control standards, and are capable of meeting published specifications after being subjected to any or all of the following physical and environmental test.

Specification	Test/Inspection Condition	Reference/Spec
Operating Temperature	-55° to 105° C Case Environment	Individual Model Data Sheet
Storage Temperature	-55° to 105°C Ambient Environment	Individual Model Data Sheet
Humidity	90 to 95% RH, 240 hours, 50°C	MIL-STD-202, Method 103, Condition A, Except 50°C and end-point electrical test done within 12 hours
Thermal Shock	-55° to 100°C, 100 cycles	MIL-STD-202, Method 107, Condition A-3, except +100°C
Solder Reflow Heat	Sn-Pb Eutectic Process 225°C peak Pb-Free Process 245° - 250°C peak	J-STD-020C, Table 4-1, 4-2 and 5-2, Figure 5-1
Solderability	10X Magnification	J-STD-002, Para 4.2.5, Test S, 95% Coverage
Vibration (high Frequency)	20g peak, 10-2000 Hz, 12 times in each of three perpendicular directions (total 36)	MIL-STD-883, Method 2007.3, Condition A
Mechanical Shock	50g, 11 ms, 1/2-sine, 18 shocks: 3 each direction, each of 3 axes	MIL-STD-202, Method 213, Condition A
Marking Resistance to Solvents	Isopropyl alcohol + mineral spirits at 25°C; terpene defluxer at 25°C; distilled water + proylene glycol monomethyl ether + monoethanolamine at 63°C to 70°C	MIL-STD-202, Method 215