



USB & ETHERNET

RMS Power Sensor

PWR-9RMS-RC

Mini-Circuits

50Ω 50 to 9000 MHz -60 to +20 dBm True RMS N-Type Male

THE BIG DEAL

- RMS (average) power measurements with 80 dB dynamic range
- Measure wideband modulated & multi-tone signals
- Measure pulsed signals with moderate duty cycles ($\geq 2\%$)
- Integrated display for quick power readings
- Ethernet & USB control

APPLICATIONS

- 5G FR1, WiFi 6E, Bluetooth device testing
- C band satcom, radio and radar testing
- Average power measurement of ASK, FSK, OFDM, QAM, LTE modulations



Generic photo used for illustration purposes only.

PRODUCT OVERVIEW

Mini-Circuits' PWR-9RMS-RC is a high-performance and cost-effective RMS power sensor for measurement of average power levels in a diverse range of test applications. The sensor operates from 50 to 9000 MHz, detecting input signals as high as +20 dBm and all the way down to -60 dBm. The compact package includes a removable rubberized outer case for protection and portability, N-type RF input connector, integrated screen, SMB trigger input / output options and Ethernet / USB control.

The included measurement software for Windows walks the user through the power sensor settings, displays the current measurements and provides powerful data recording and export capabilities. A full API for Windows is also provided, with programming instructions and examples for Windows and Linux systems to set up automated power measurements in a range of common programming environments. Full control is available via Ethernet and USB, with the integrated screen providing a convenient local read-out to the operator of power measurements and key settings.

Mini-Circuits has a wide range of high-performance power sensors available on our [website](#). Consider the [PWR-9PWHS-RC](#) peak power sensor if measurements of fast pulses, high crest factor signals or pulse rise / fall times are needed.

KEY FEATURES

Feature	Advantages
True RMS sensor	Cost effective measurements of average power levels over time for a wide range of applications. Measure CW, modulated, pulsed and multi-tone signals with a single sensor.
Wide measurement bandwidth	Accurately measure multi-tone signals and wideband digital modulations (including WiFi devices). The sensor is calibrated for highly accurate average power measurements of signals with bandwidths up to ~100 MHz. Repeatable measurements will be returned over even wider bandwidths (subject to a roll-off in absolute accuracy), permitting use of the sensor for comparison of relative signal levels.
Automatic measurement compensation	Start measuring straight away. The sensor automatically compensates power measurements based on the internal ambient temperature sensor and the user entered measurement frequency.
Flexible control options	Connect with a PC via either Ethernet or USB and measure using the included measurement software or API for automation. Once configured and powered, the sensor can be used as a standalone tool with measurements displayed on the integrated screen.
Trigger in / out	Synchronize measurements between test instrumentation using the external trigger input / output ports.

Trademarks:

Windows is a registered trademark of Microsoft Corporation in the United States and other countries ; Linux is a registered trademark of Linus Torvalds ; Pentium is a registered trademark of Intel Corporation. Neither Mini-Circuits nor the Mini-Circuits products are affiliated with or endorsed by the owners of the referenced trademarks. Mini-Circuits and the Mini-Circuits logo are registered trademarks of Scientific Components Corporation.



ELECTRICAL SPECIFICATIONS, 25°C^{1,2}

Parameter	Conditions	Frequency (MHz)	Min.	Typ.	Max.	Unit
Frequency Range	-	-	0.05	-	9	GHz
Input Power Range	-	50 - 9000	-60	-	+20	dBm
Uncertainty of Power Measurement, +25°C ³	-60 to -50 dBm	50 - 9000	-	±0.2	±0.6	dB
	-50 to +20 dBm	50 - 9000	-	±0.2	±0.4	
Uncertainty of Power Measurement, 0°C to +50°C ³	-60 to +20 dBm	50 - 9000	-	±0.4	-	dB
Return Loss	-	50 - 9000	18	25	-	dB
Linearity, +25°C	-	50 - 9000	-	2	-	%
Measurement Resolution	-	50 - 9000	0.01	-	-	dB
Averaging Range	-	50 - 9000	1	-	999	-
Measurement Time (including typical USB delays)	Sample Period= 0.1 ms ⁴	50 - 9000	-	0.5	-	ms
	Sample Period= 1000 ms	50 - 9000	-	2500	-	
Sample Period	-	50 - 9000	0.1	-	1000	ms
Video Bandwidth	-	50 - 9000	-	-	100	MHz
DC Current (I _{DC})	Ethernet disabled	50 - 9000	-	425	500	mA
	Ethernet enabled ⁵		-	475	550	
Trigger In	Logic Low	-	0	-	0.6	V
	Logic High	-	2.7	-	5.5	
Trigger Out ⁶ (into high impedance load)	Logic Low	-	0	-	0.3	
	Logic High	-	3	-	5.2	
Pulse Modulation	Pulse Width/Interval ⁷	50 - 9000	500	-	-	μs
	Duty Cycle		2	-	98	%
Effect of Multi-Tone Signals (within span of 100 MHz)	-	50 - 9000	-	±0.1	-	dB

1. All specifications after 30 minutes warmup time and zeroing.

2. Maximum continuous safe operational power limit: +23 dBm.

3. Tested with CW signal and default sample period. For Sample period < (10 x Signal period), maintain Sample period = (N x Signal period).

4. With "Buffer Mode" setting enabled and "Screen Display - On" setting disabled.

5. When Ethernet control is enabled, it is recommended to use an external power supply (USB-AC/DC-5 or equivalent), a powered hub, or USB 3.0/3.1 port, in order to supply the current.

6. Trigger Out is set momentarily to logic high after each sample period.

7. For sample periods 20 ms or less. Minimum pulse & interval increase for sample periods greater than 20 ms.



UNCERTAINTY OF POWER MEASUREMENT WITH DIGITAL MODULATION, 25°C⁸

Modulation	Conditions (dBm)	Frequency (MHz)	Min.	Typ.	Max.	Unit
QPSK, QAM16 & QAM64 in LTE uplink setup (1.4 MHz channels, 3.7 MHz offsets)	-50	50 - 9000	-	±0.2	-	dB
	-30		-	±0.2	-	
	-10		-	±0.2	-	
	+10		-	±0.2	-	
QPSK in WiMax setup (10 MHz channel, 22.4 MHz sample clock)	-50	50 - 9000	-	±0.2	-	dB
	-30		-	±0.2	-	
	-10		-	±0.2	-	
	+10		-	±0.2	-	
64QAM in WLAN setup (10 MHz channel, 22.4 MHz sample clock)	-50	50 - 9000	-	±0.2	-	dB
	-30		-	±0.2	-	
	-10		-	±0.2	-	
	+10		-	±0.2	-	
MSK in GSM setup (Gaussian filter @270,833 sps)	-50	50 - 9000	-	±0.2	-	dB
	-30		-	±0.2	-	
	-10		-	±0.2	-	
	+10		-	±0.2	-	
DQPSK in NADC setup (RNYQ filter @ 24.3 ksps)	-50	50 - 9000	-	±0.2	-	dB
	-30		-	±0.2	-	
	-10		-	±0.2	-	
	+10		-	±0.2	-	
DQPSK in PWT setup (RNYQ filter @ 576 ksps)	-50	50 - 9000	-	±0.2	-	dB
	-30		-	±0.2	-	
	-10		-	±0.2	-	
	+10		-	±0.2	-	
256QAM in DECT setup (Gaussian filter @ 1.152Mpsps)	-50	50 - 9000	-	±0.2	-	dB
	-30		-	±0.2	-	
	-10		-	±0.2	-	
	+10		-	±0.2	-	
4QAM in PHS setup (RNYQ filter @ 192ksps)	-50	50 - 9000	-	±0.2	-	dB
	-30		-	±0.2	-	
	-10		-	±0.2	-	
	+10		-	±0.2	-	

8. Digital modulation transmission rates are measured in "symbols per second" (sps) and use a bandpass filter on the output to limit spectral spreading.



TYPICAL PERFORMANCE GRAPHS

Uncertainty in Power Measurement @ Low Power Input

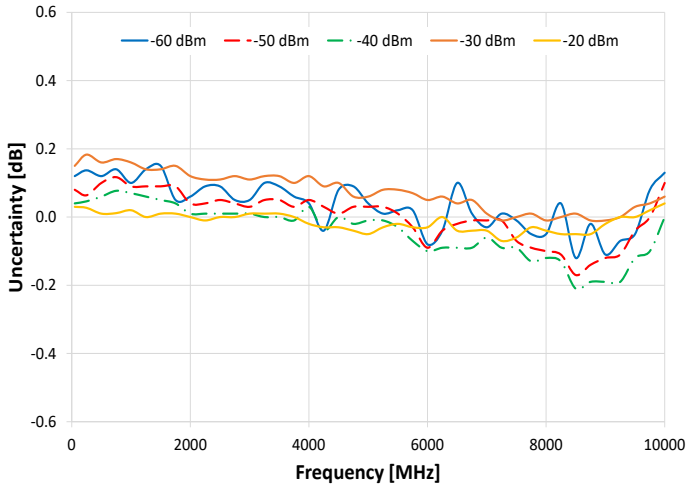

Uncertainty in Power Measurement @ High Power Input

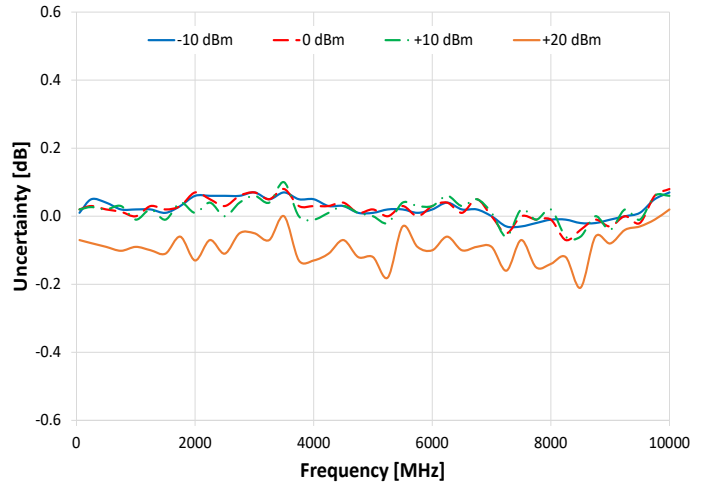

Linearity vs. Frequency

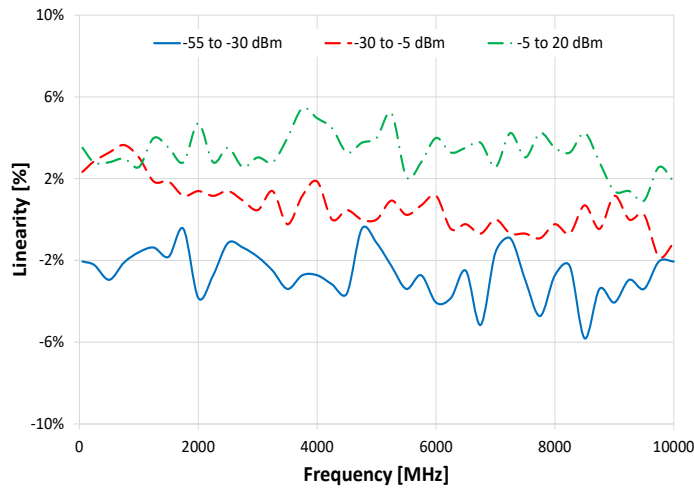

Return Loss vs. Frequency

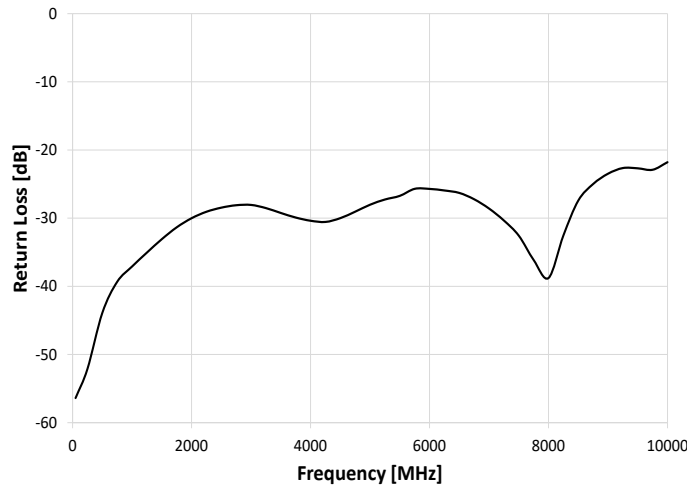

**CONTROL INTERFACES**

Ethernet Control	Supported Protocols	TCP / IP, HTTP, Telnet, DHCP, UDP (limited)
	Max Data Rate	100 Mbps (100 Base-T Full Duplex)
USB Control	Supported Protocols	HID (Human Interface Device) - High-speed
	Min Communication Time ⁹	400 μs typ (full transmit/receive cycle)

9. USB Min Communication Time is based on the polling interval of the USB HID protocol (125 μs polling interval, 64 bytes per packet), medium CPU load and no other high-speed USB devices using the USB bus.

SOFTWARE & DOCUMENTATION

Mini-Circuits' full software and support package including user guide, Windows GUI, API, programming manual and examples can be downloaded free of charge (refer to the last page for the download path).

A comprehensive set of software control options is provided:

- GUI for Windows – Simple software interface for control via Ethernet and USB.
- Programming / automation via Ethernet:
 - Complete set of control commands which can be sent via any supported protocol.
 - Simple to implement in the majority of modern programming environments.
- Programming / automation via USB:
 - DLL files provide a full API for Windows with a set of intuitive functions which can be implemented in any programming environment supporting .Net Framework or ActiveX.
 - Direct USB programming is possible in any other environment (not supporting .Net or ActiveX).

Please contact testsolutions@minicircuits.com for support.

MINIMUM SYSTEM REQUIREMENTS

GUI	Windows 7 or later
USB API DLL	Windows 7 or later and programming environment with ActiveX or .NET support
USB Direct Programming	Linux, Windows 7 or later
HTTP or Telnet	Any computer with a network port and Ethernet-TCP/IP (HTTP or Telnet protocols) support
Hardware	Intel i3 (or equivalent) or later
Control Cable	Power sensor to be used with the supplied USB cable only



GRAPHICAL USER INTERFACE (GUI) FOR WINDOWS - KEY FEATURES

- Connect via USB or Ethernet (HTTP, Telnet) to control the module.
- Control multiple power sensors at once.

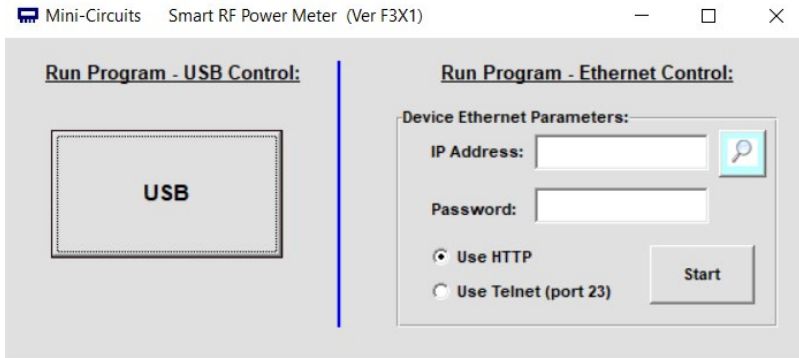

- Set compensation frequency and monitor power measurement.
- Configure measurement (offsets, relative power readings, averaging, set trigger mode, etc.).
- Zero the power sensor (recommended at the start of a new measurement session).
- Schedule data recording.

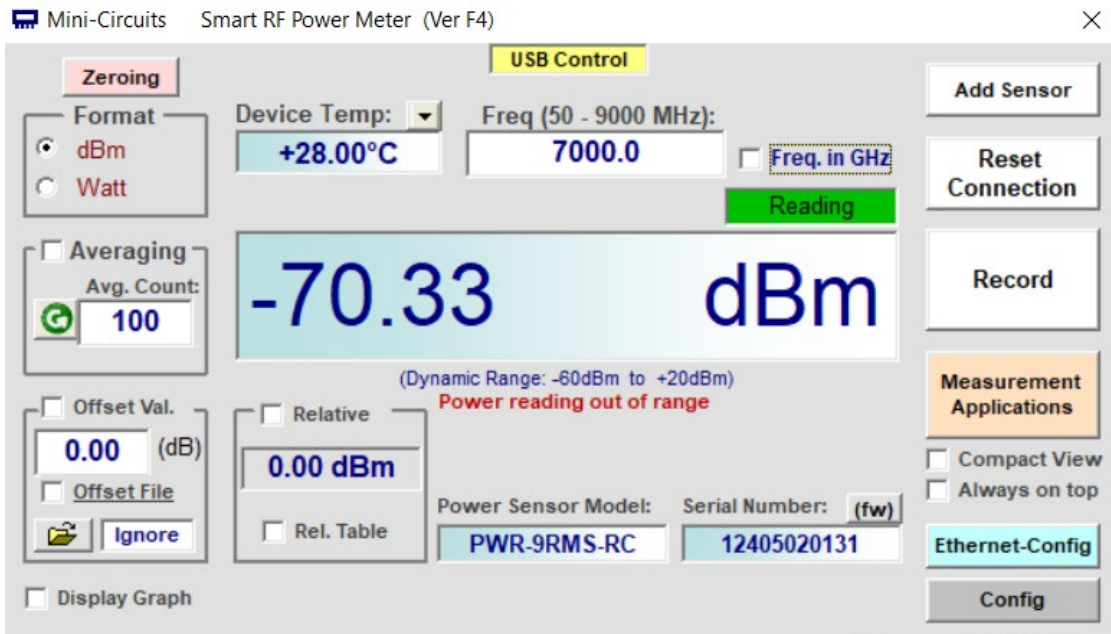



GUI - CONFIGURATION SCREEN

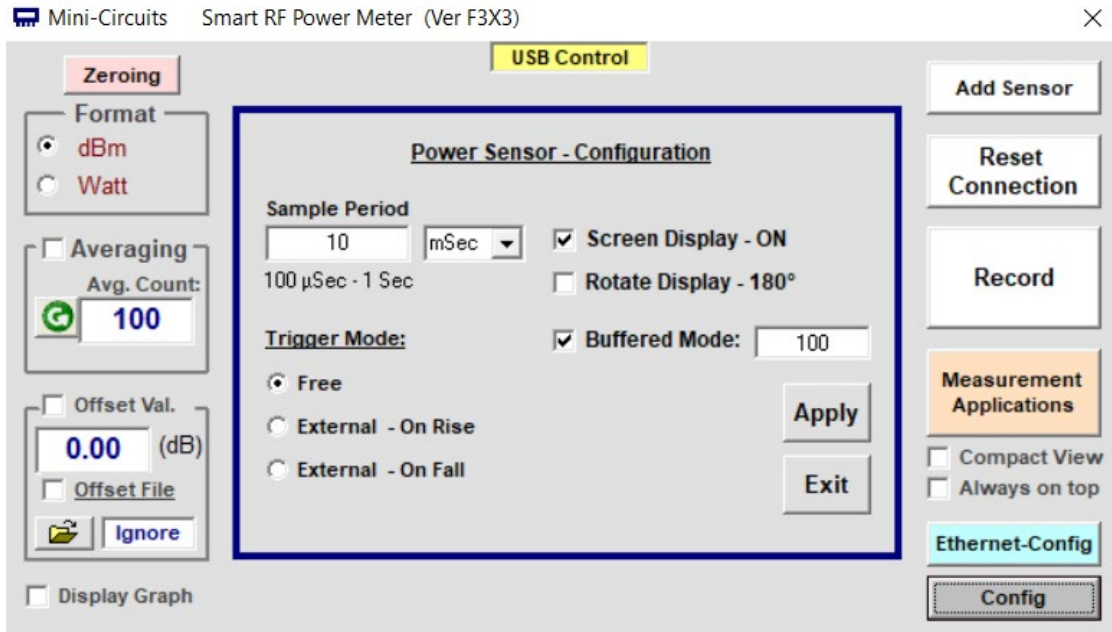

- Set the sample period (the time over which the sensor will average the power) between 100 μ s and 1s.
- Select from 3 trigger options:
 1. Free – No trigger / free running measurements.
 2. External On Rise – Measurements are triggered on the rising edge of an external trigger signal.
 3. External On Fall – Measurements are triggered on the falling edge of an external trigger signal.
- Set the buffer size to send over the latest X number of measurements once a SCPI command is received (refer to [programming manual](#) for details).



BLOCK DIAGRAM

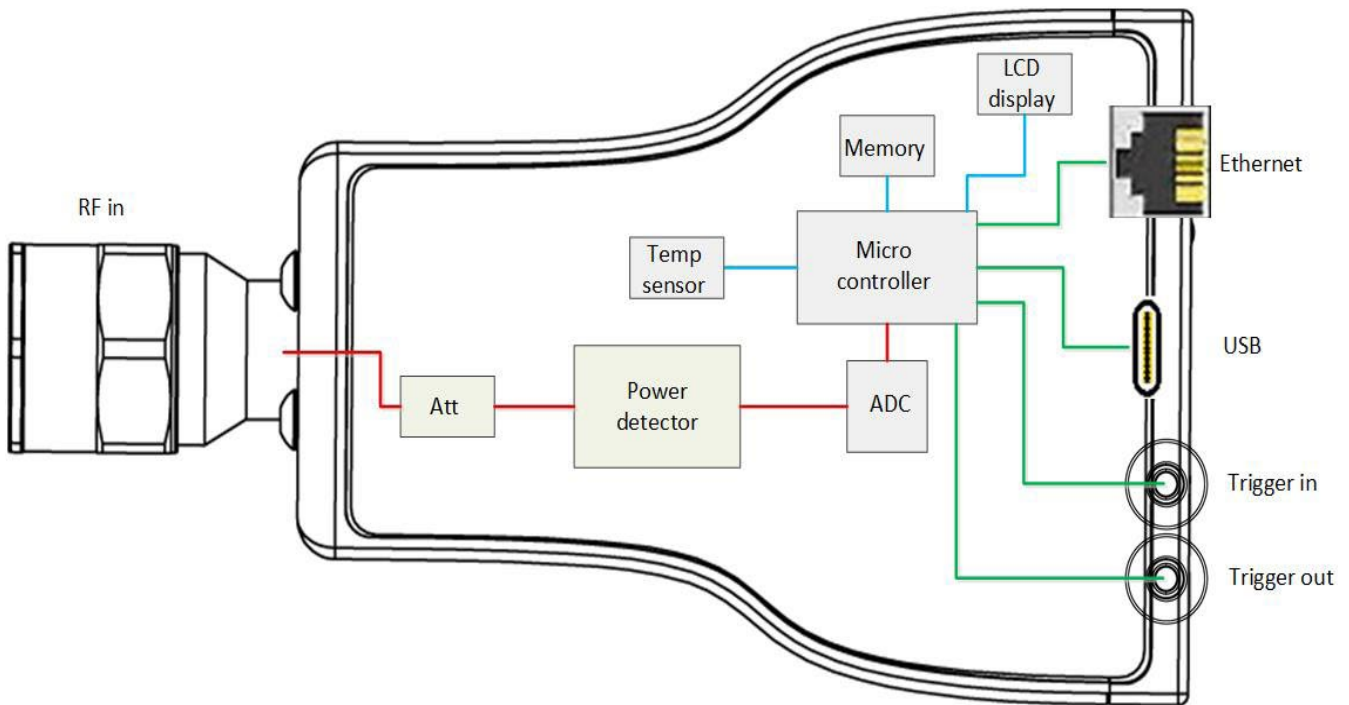

ABSOLUTE MAXIMUM RATINGS^{10, 11}

Operating Temperature	0°C to +50°C
Storage Temperature	-30°C to +70°C
DC Voltage at RF Ports	5 V
Trigger In	-0.3 to 5.5 V
CW Power	+26 dBm

10. Permanent damage may occur if any of these limits are exceeded.
 11. Operating in the range between operating power limits and absolute maximum ratings for extended periods of time may result in reduced life and reliability.

CONNECTIONS

Port Name	Connector Type
RF Input	N-type Male
Trigger In	SMB Male
Trigger Out	SMB Male
USB	USB type-C (with screw lock)
Ethernet	RJ45 Socket



CASE STYLE DRAWING (JL3470)

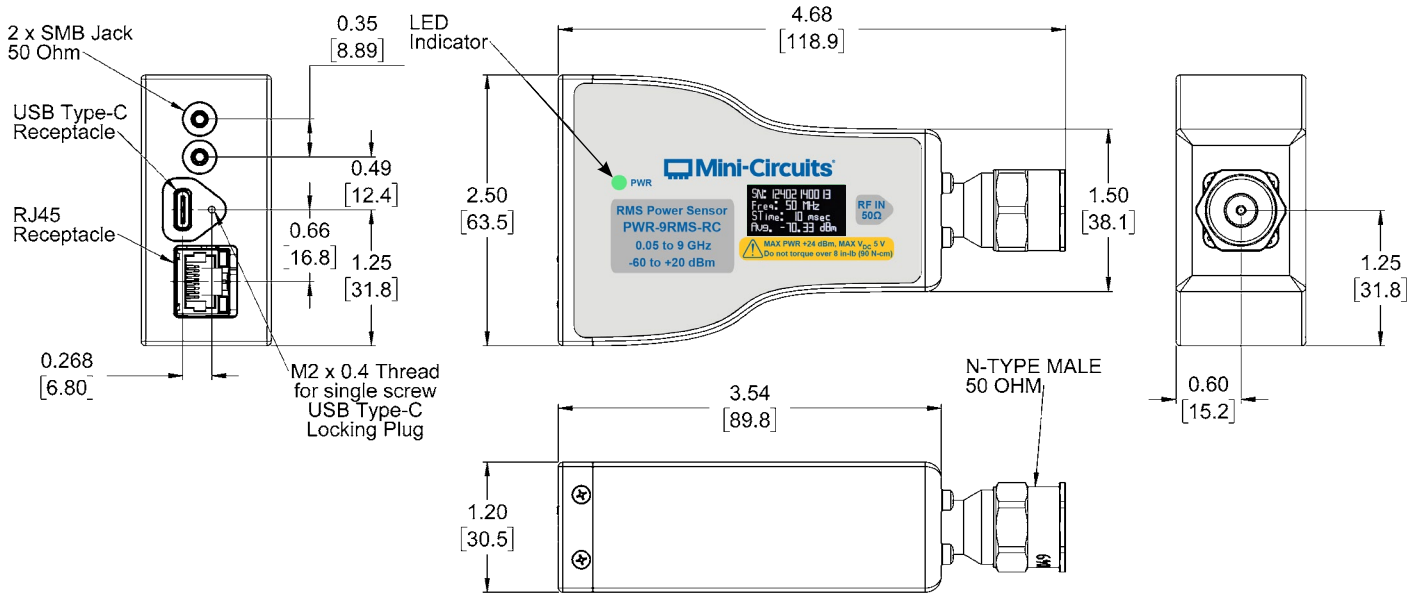

NOTES:

1. Case material: Aluminum alloy.
2. Case Finish: Nickel Plate.
3. Dimensions: Inches [mm].
Tolerances 2 Pl. ±.03 inch; 3 Pl. ±.015 inch.
4. Weight: 260 grams
5. Marking may contain other features or characters for internal lot control.
6. Maximum torque 8 in-lb (90 N-cm).
7. Unit provided with removable protective sleeve (see image below).

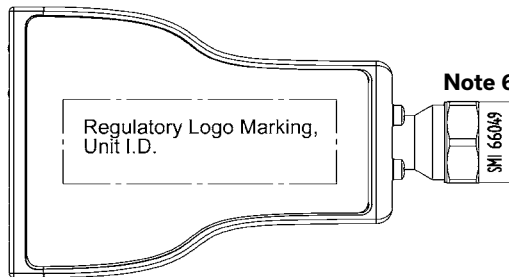

Note 7





CONNECTION DIAGRAMS USB CONTROL

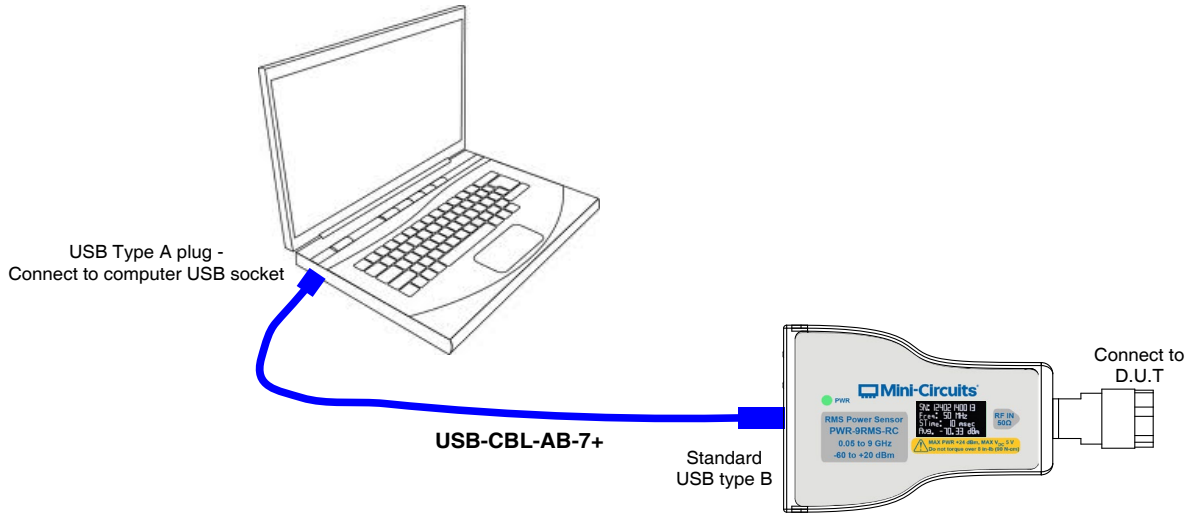

ETHERNET CONTROL (USING POWER ADAPTER)

Connect USB-AC/DC-5
to mains power

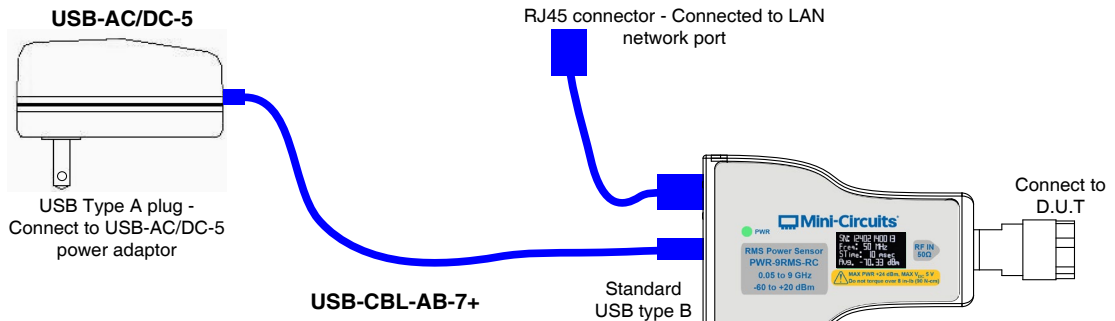

ETHERNET CONTROL (USING POE SYSTEM)

Note:
Commercially available PoE splitter
not supplied by Mini-Circuits.

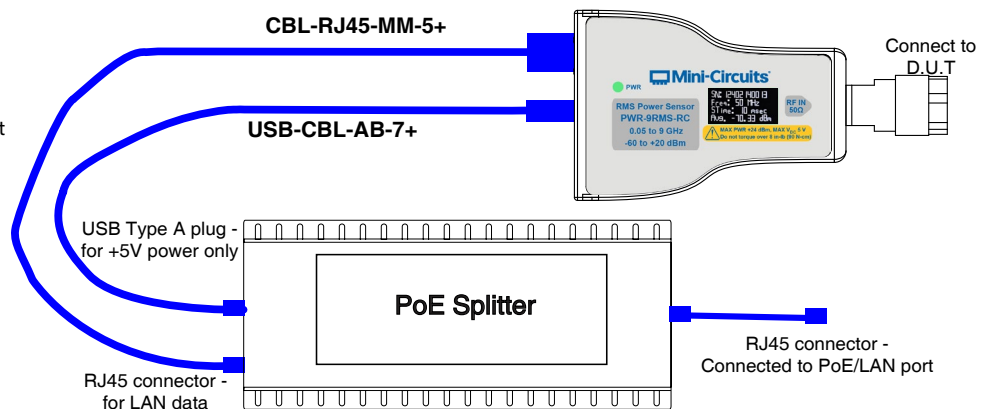



USB & ETHERNET

RMS Power Sensor

PWR-9RMS-RC





50Ω 50 to 9000 MHz -60 to +20 dBm True RMS N-Type Male

DETAILED MODEL INFORMATION IS AVAILABLE ON OUR WEBSITE [CLICK HERE](#)





Performance Data & Graphs	Data Graphs
Case Style	JL3470
Environmental Rating	ENV50
Software, User Guide & Programming Manual	https://www.minicircuits.com/softwaredownload/pm.html
Regulatory Compliance	Refer to user guide for compliance information  https://www.minicircuits.com/app/AN48-003.pdf
Support	testsolutions@minicircuits.com

INCLUDED ACCESSORIES ¹²

	Part No.	Description	Qty.
	USB-CBL-AC-7SC+	7.0 ft (2.0 m) USB Cable: USB type A (Male) to USB type C (Male)	1
	CBL-5FT-BMSMB+	5.0 ft (1.5 m) Trigger cable: BNC (Male) to SMB (Female)	1

12. Additional quantities are available for purchase as optional accessories.

OPTIONAL ACCESSORIES

	Part No.	Description
	CBL-RJ45-MM-5+	5.0 ft (1.5 m) Ethernet cable: RJ45 (Male) to RJ45 (Male) Cat 5E cable
	NF-SF50+	N-Type Female to SMA Female Adapter
	NF-SM50+	N-Type Female to SMA Male Adapter
	NF-BM50+	N-Type Female to BNC Male Adapter
	USB-AC/DC-5+	AC/DC +5V power adaptor with USB connector ^{13,14}

13. Includes power plugs for US, UK, EU, IL, AU & China. Plugs for other countries are also available. If you need a power cord for a country not listed please contact testsolutions@minicircuits.com

14. Power adaptor, powered hub or USB 3.0/3.1 port may be used to provide power when in Ethernet control, not needed in USB control.

CALIBRATION

Part No.	Description
CALSEN-9RMS-RC	Calibration Service for PWR-9RMS-RC CLICK HERE

NOTES:

- A. Performance and quality attributes and conditions not expressly stated in this specification document are intended to be excluded and do not form a part of this specification document.
- B. Electrical specifications and performance data contained in this specification document are based on Mini-Circuit's applicable established test performance criteria and measurement instructions.
- C. The parts covered by this specification document are subject to Mini-Circuits standard limited warranty and terms and conditions (collectively, "Standard Terms"); Purchasers of this part are entitled to the rights and benefits contained therein. For a full statement of the Standard Terms and the exclusive rights and remedies thereunder, please visit Mini-Circuits' website at <https://www.minicircuits.com/terms/viewterm.html>



RMS Power Sensor

PWR-9RMS-RC

Typical Performance Data

Test Conditions: @ Temperature = 25°C (unless otherwise stated).

Freq. (MHz)	Uncertainty of power measurement (dBm)								
	-60 dBm	-50 dBm	-40 dBm	-30 dBm	-20 dBm	-10 dBm	0 dBm	+10 dBm	+20 dBm
50	0.12	0.08	0.04	0.15	0.03	0.01	0.02	0.02	-0.07
250	0.14	0.06	0.05	0.18	0.03	0.05	0.03	0.03	-0.08
500	0.12	0.10	0.06	0.16	0.01	0.04	0.02	0.02	-0.09
750	0.14	0.12	0.08	0.17	0.01	0.02	0.01	0.03	-0.10
1000	0.10	0.09	0.07	0.16	0.02	0.02	0.00	-0.01	-0.09
1250	0.14	0.09	0.06	0.14	0.00	0.02	0.03	0.02	-0.10
1500	0.15	0.09	0.05	0.14	0.01	0.01	0.02	-0.01	-0.11
1750	0.05	0.09	0.04	0.15	0.01	0.03	0.03	0.04	-0.06
2000	0.06	0.04	0.01	0.12	0.00	0.06	0.07	0.01	-0.13
2250	0.09	0.04	0.01	0.11	-0.01	0.06	0.05	0.04	-0.07
2500	0.09	0.05	0.01	0.11	0.00	0.06	0.03	0.00	-0.11
2750	0.05	0.04	0.01	0.12	0.00	0.06	0.06	0.04	-0.05
3000	0.05	0.03	0.01	0.11	0.01	0.07	0.07	0.06	-0.05
3250	0.10	0.05	0.00	0.12	0.01	0.05	0.05	0.04	-0.07
3500	0.09	0.05	0.00	0.12	0.01	0.07	0.08	0.10	0.00
3750	0.06	0.03	-0.01	0.10	0.00	0.05	0.03	0.00	-0.13
4000	0.04	0.05	0.03	0.12	-0.02	0.05	0.03	-0.01	-0.13
4250	-0.04	0.03	-0.04	0.09	-0.03	0.03	0.03	0.01	-0.11
4500	0.08	0.01	0.00	0.10	-0.03	0.03	0.04	0.03	-0.07
4750	0.09	0.03	-0.02	0.06	-0.04	0.01	0.01	0.01	-0.12
5000	0.04	0.03	-0.01	0.06	-0.05	0.01	0.02	0.00	-0.12
5250	0.01	0.03	-0.01	0.08	-0.03	0.02	0.00	-0.02	-0.18
5500	0.02	0.01	-0.03	0.08	-0.02	0.02	0.03	0.04	-0.03
5750	0.02	-0.03	-0.07	0.07	-0.03	0.01	0.00	0.03	-0.09
6000	-0.08	-0.09	-0.10	0.05	-0.03	0.02	0.03	0.03	-0.10
6250	-0.04	-0.04	-0.09	0.06	0.00	0.04	0.04	0.06	-0.06
6500	0.10	-0.02	-0.09	0.04	-0.04	0.02	0.01	0.03	-0.10
6750	0.01	-0.01	-0.09	0.05	-0.04	0.02	0.05	0.05	-0.09
7000	-0.03	-0.01	-0.06	0.01	-0.04	0.00	0.00	0.01	-0.09
7250	0.01	-0.01	-0.09	-0.01	-0.07	-0.03	-0.05	-0.06	-0.16
7500	-0.01	-0.07	-0.09	0.00	-0.06	-0.03	0.00	0.02	-0.07
7750	-0.05	-0.09	-0.13	0.01	-0.03	-0.02	-0.01	-0.01	-0.15
8000	-0.05	-0.10	-0.12	-0.01	-0.04	-0.01	-0.01	0.02	-0.14
8250	0.04	-0.11	-0.13	0.00	-0.05	-0.01	-0.07	-0.06	-0.12
8500	-0.12	-0.17	-0.21	0.01	-0.05	-0.02	-0.04	-0.06	-0.21
8750	-0.02	-0.14	-0.19	-0.01	-0.05	-0.02	-0.01	0.00	-0.06
9000	-0.11	-0.12	-0.19	-0.01	-0.02	-0.01	-0.03	-0.04	-0.08
9250	-0.07	-0.11	-0.19	0.00	0.00	0.00	0.00	0.02	-0.04
9500	-0.05	-0.04	-0.12	0.03	0.00	0.01	-0.02	-0.01	-0.03
9750	0.08	0.00	-0.10	0.04	0.02	0.05	0.06	0.06	-0.01
10000	0.13	0.10	0.00	0.06	0.04	0.07	0.08	0.06	0.02

RMS Power Sensor

Typical Performance Data

Test Conditions: @ Temperature = 25°C (unless otherwise stated).

Freq. (MHz)	Linearity (%)		
	-55 to -30 dBm	-30 to -5 dBm	-5 to 20 dBm
50	-2.05%	2.33%	3.51%
250	-2.23%	2.86%	2.78%
500	-2.95%	3.28%	2.80%
750	-2.10%	3.64%	2.98%
1000	-1.60%	3.04%	2.57%
1250	-1.37%	1.86%	3.99%
1500	-1.83%	1.86%	3.51%
1750	-0.46%	1.16%	2.80%
2000	-3.84%	1.39%	4.71%
2250	-2.73%	1.16%	2.80%
2500	-1.14%	1.39%	3.51%
2750	-1.37%	0.93%	2.57%
3000	-1.83%	0.46%	3.04%
3250	-2.50%	1.39%	2.80%
3500	-3.39%	-0.23%	3.99%
3750	-2.73%	1.16%	5.44%
4000	-2.73%	1.86%	4.95%
4250	-3.17%	0.00%	4.47%
4500	-3.62%	0.46%	3.28%
4750	-0.46%	0.00%	3.75%
5000	-1.14%	0.00%	3.99%
5250	-2.28%	0.93%	5.20%
5500	-3.39%	0.23%	2.09%
5750	-2.73%	0.69%	2.80%
6000	-4.06%	1.16%	3.99%
6250	-3.84%	-0.46%	3.28%
6500	-2.50%	-0.23%	3.51%
6750	-5.16%	-0.69%	3.75%
7000	-1.60%	0.00%	2.57%
7250	-0.92%	-0.69%	4.23%
7500	-2.95%	-0.69%	3.04%
7750	-4.72%	-0.92%	4.23%
8000	-2.73%	-0.23%	3.51%
8250	-2.28%	-0.69%	3.28%
8500	-5.81%	0.69%	4.23%
8750	-3.39%	-0.46%	2.80%
9000	-4.06%	1.16%	1.39%
9250	-2.95%	0.00%	1.39%
9500	-3.39%	0.23%	0.93%
9750	-2.05%	-1.83%	2.57%
10000	-2.05%	-1.14%	1.86%

Freq. (MHz)	R. Loss (dB)
50	-56.39
250	-52.11
500	-43.89
750	-39.33
1000	-37.09
1250	-35.05
1500	-33.08
1750	-31.35
2000	-30.01
2250	-29.06
2500	-28.46
2750	-28.11
3000	-28.06
3250	-28.53
3500	-29.24
3750	-29.91
4000	-30.38
4250	-30.56
4500	-30.00
4750	-29.05
5000	-28.03
5250	-27.27
5500	-26.73
5750	-25.70
6000	-25.71
6250	-25.94
6500	-26.30
6750	-27.23
7000	-28.59
7250	-30.35
7500	-32.57
7750	-36.14
8000	-38.78
8250	-32.54
8500	-27.42
8750	-24.99
9000	-23.48
9250	-22.65
9500	-22.69
9750	-22.90
10000	-21.79

Typical Performance Graphs

Test Conditions: @ Temperature = 25°C (unless otherwise stated).

Uncertainty in Power Measurement @ Low Power Input

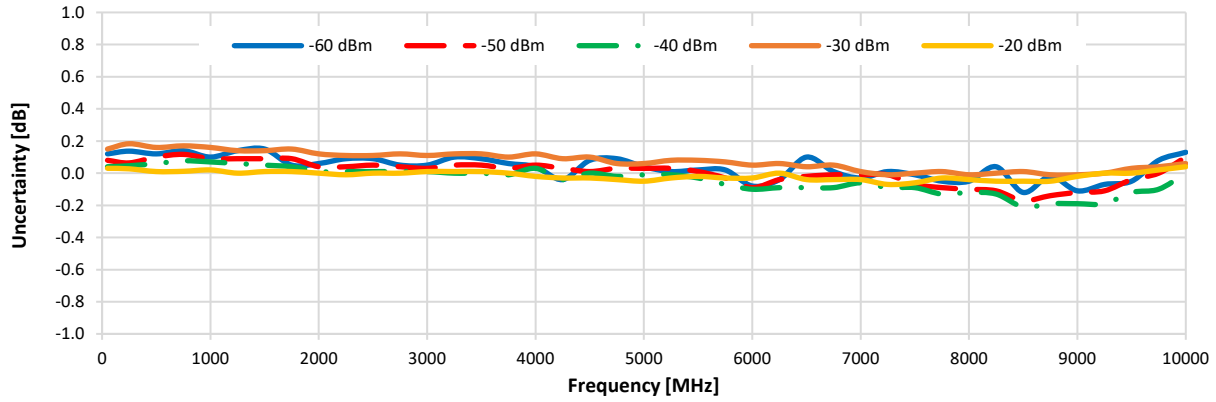

Uncertainty in Power Measurement @ High Power Input

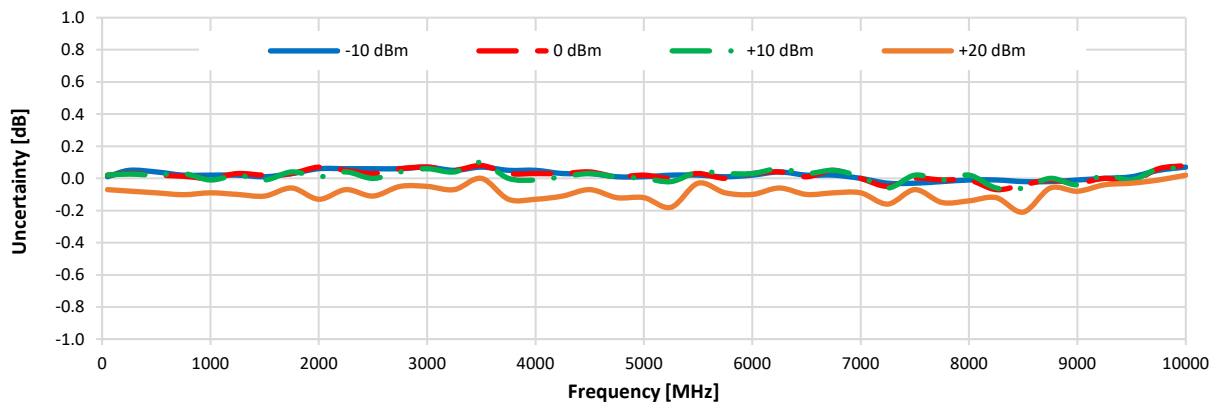

Typical Performance Graphs

Test Conditions: @ Temperature = 25°C (unless otherwise stated).

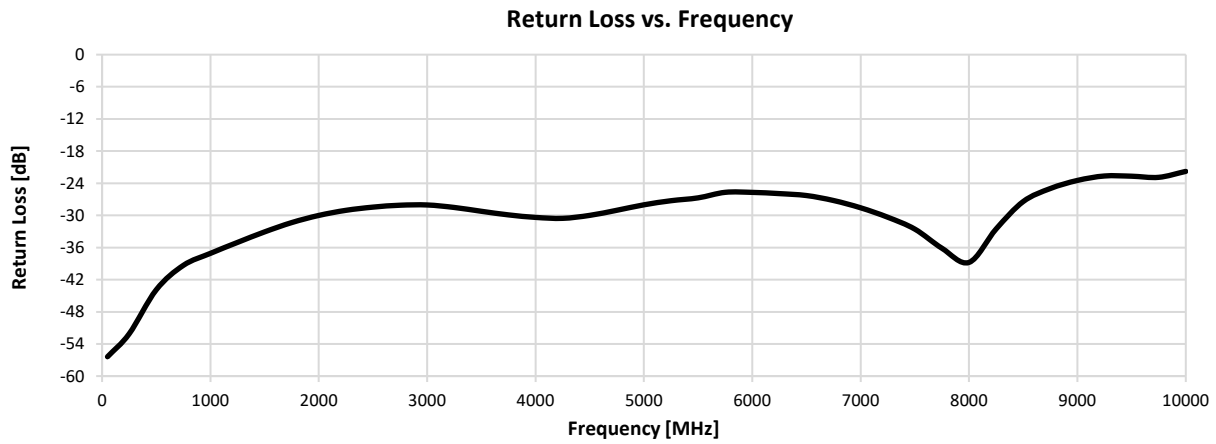
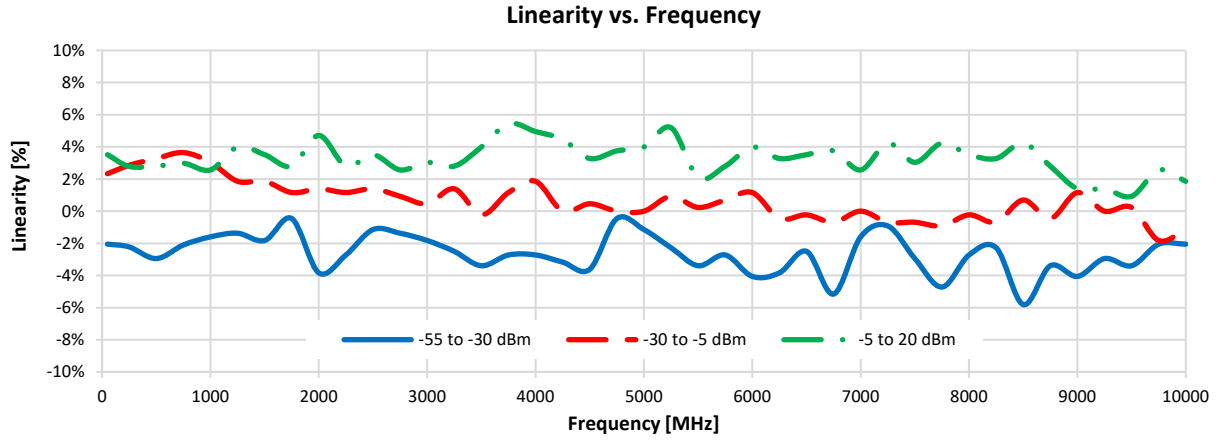

Case Style

JL

Outline Dimensions

JL3470

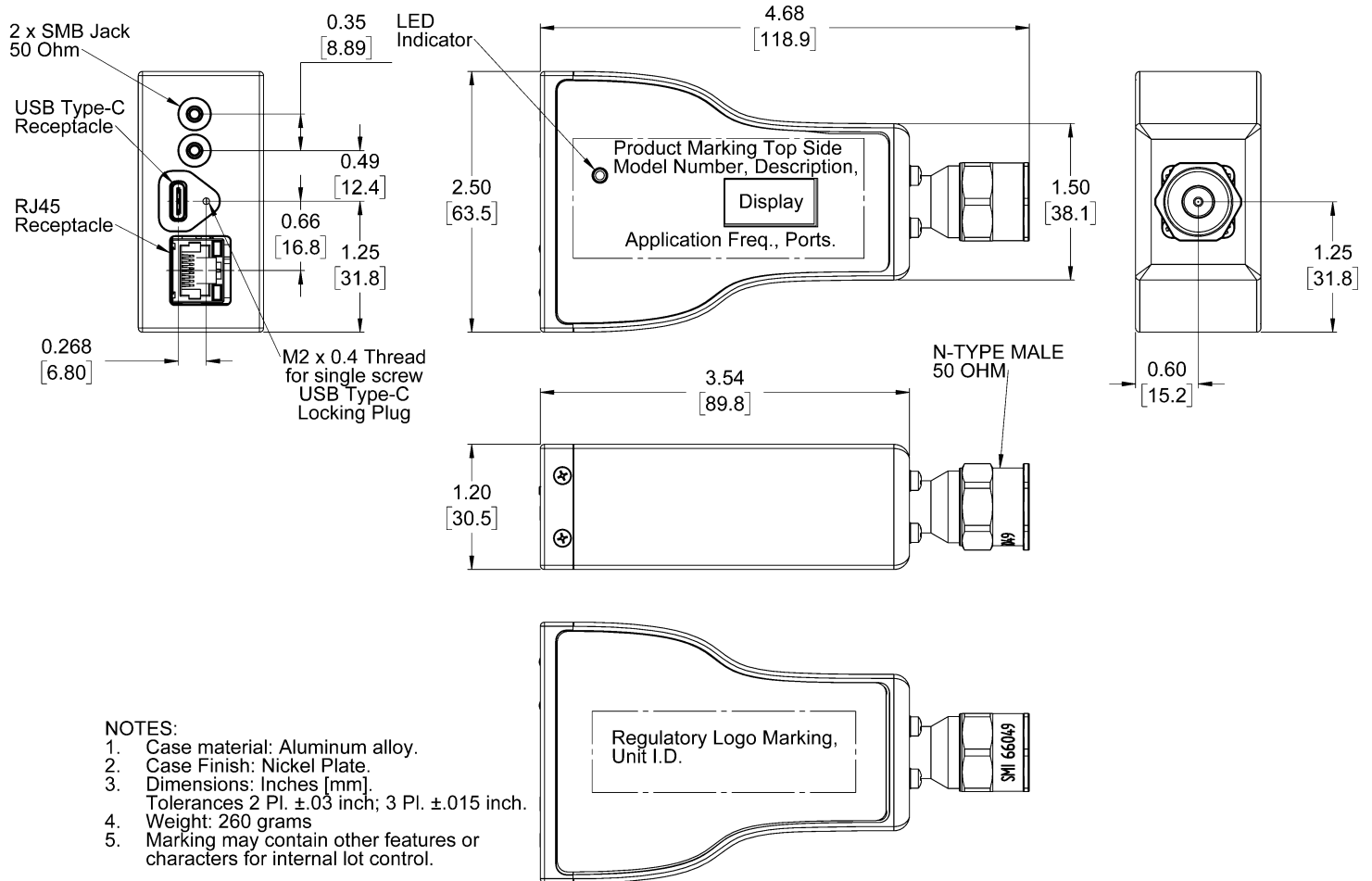

www.minicircuits.com P.O. Box 350166, Brooklyn, NY 11235-0003 (718) 934-4500 sales@minicircuits.com



Environmental Specifications **ENV50**

All Mini-Circuits products are manufactured under exacting quality assurance and control standards, and are capable of meeting published specifications after being subjected to any or all of the following physical and environmental test.

Specification	Test/Inspection Condition	Reference/Spec
Operating Temperature	-0° to 50° C Ambient Environment	Individual Model Data Sheet
Storage Temperature	-30° to 70° C Ambient Environment	Individual Model Data Sheet
Operating and Storage Humidity	5% to 85% RH (non-condensing)	Ambient
Bench Handling Test	Bench Top Tip 45° & Drop	MIL-PRF-28800F
Transit Drop Test	Free Fall Drop, 20 cm (7.9 inches)	MIL-PRF-28800F Class 3