

Smart Power Sensor

PWR-40PW-RC

50Ω -20 dBm to +20 dBm, 0.5 to 40 GHz

The Big Deal

- Peak, average, crest factor & duty cycle measurements
- Modulated, pulsed & CW signal types
- 30 MHz video bandwidth
- 20 million samples / sec
- **USB and Ethernet** control

Typical Applications

- 5G NR device testing
- ASK, FSK, OFDM, QAM, LTE modulations
- K / Ka band radar
- Signal level calibration
- Remote power monitoring

Product Overview

Mini-Circuits' PWR-40PW-RC is a high performance sensor for any power measurement application from 500 MHz to 40 GHz. The 10 MHz internal modulation bandwidth, coupled with a data processing rate of 20 million samples-per-second, enables measurement of a wide range of analog & digital modulation types. The video output port additionally provides 30 MHz video bandwidth for additional analysis or Automatic level control circuits.

The software provides peak & average power measurements, statistical analysis (crest factor, duty cycle, rise / fall time) and time domain plots for any signal type, including pulsed waveforms down to 100 ns pulse width and 0.1% duty cycle.

The power meter has USB and Ethernet interfaces, allowing control directly from a PC, or remote power measurement over a network. Full software support is provided, including our user-friendly GUI application for Windows and a full API with programming instructions for Windows and Linux environments (both 32-bit and 64-bit systems). Download from <http://www.minicircuits.com/softwaredownload/pm.html>

Key Features

Feature	Advantages
Peak, average and pulse profiling	Measure peak & average power of CW and modulated signals. Analyze and graphically plot the peak & average power, duty cycle, pulse width, crest factor, rise & fall times of pulsed signals.
External trigger controls	Trigger in and out ports support precise synchronization with external test equipment, allowing capture of irregular signal patterns & pulses.
Selectable video BW	Switch between CW, 1.5 MHz, 5 MHz & 10 MHz video bandwidths on demand to minimize measurement noise.
Video output port	Use in ALC (automatic level control) loops or observe the modulated signal directly on an oscilloscope for highest bandwidth

Trademarks: Windows is a registered trademark of Microsoft Corporation in the United States and other countries. Linux is a registered trademark of Linus Torvalds. Mac is a registered trademark of Apple Corporation. Pentium is a registered trademark of Intel Corporation. Neither Mini-Circuits nor the Mini-Circuits PWR-series power sensors are affiliated with or endorsed by the owners of the above referenced trademarks

Mini-Circuits and the Mini-Circuits logo are registered trademarks of Scientific Components Corporation.



Generic photo used for illustration purposes only
CASE STYLE: JL3257

Software Package

Model No.	Description
PWR-40PW-RC	USB smart Power Sensor
Included Accessories	
PWR-SEN-40PW-RC	Power Sensor Head
USB-CBL-AB-7+	6.8 ft USB cable
CBL-5FT-BMSMB+	BNC(M) to SMB(F) Trigger cable

RoHS Compliant

See our web site for RoHS Compliance methodologies and qualifications

Electrical Specifications, -20 dBm to +20 dBm, 0.5 to 40 GHz

Parameter		Freq. Range (GHz)	Min.	Typ.	Max.	Units
Dynamic range ¹		0.5 - 40	-20	-	+20	dBm
VSWR		0.5 - 15	-	1.20	1.3	:1
		15 - 40	-	1.30	1.4	
Uncertainty of power measurement ^{2,3} @ 25°C	@ -20 to -18 dBm	0.5 - 15	-	±0.10	±0.60	dB
		15 - 32	-	±0.25	±0.60	
		32 - 40	-	±0.30	±0.60	
	@ -18 to 0 dBm	0.5 - 15	-	±0.10	±0.40	dB
		15 - 32	-	±0.20	±0.40	
		32 - 40	-	±0.30	±0.40	
	@ 0 to +20 dBm	0.5 - 15	-	±0.10	±0.40	dB
		15 - 32	-	±0.20	±0.40	
		32 - 40	-	±0.30	±0.40	
Uncertainty of power measurement ^{2,3} @ 0°C to 50°C	@ -20 to -18 dBm ⁴	0.5 - 15	-	±0.50	-	dB
		15 - 32	-	±0.50	-	
		32 - 40	-	±0.50	-	
	@ -18 to 0 dBm ⁴	0.5 - 15	-	±0.50	-	dB
		15 - 32	-	±0.50	-	
		32 - 40	-	±0.50	-	
	@ 0 to +20 dBm	0.5 - 15	-	±0.50	-	dB
		15 - 32	-	±0.50	-	
		32 - 40	-	±0.50	-	
Linearity @ 25°C		0.5 - 40	-	2	-	%
Measurement resolution		0.5 - 40	0.01	-	-	dB
Internal trigger accuracy ⁵		0.5 - 40	-	1	-	dB
Averaging range		0.5 - 40	1	-	999	-
Sample period	@ full sampling rate	0.5 - 40	4	-	80	µs
	@ reduced sampling rate ⁶	0.5 - 40	-	-	1,000,000	
Time base accuracy		-	-	-	50	ppm
Max sample rate @ sample period ≤ 80 µs ⁷		0.5 - 40	-	20	-	Msp/s
Video Bandwidth	Internal Pulse profiling ⁸	0.5 - 40	-	-	10	MHz
	Video out port	0.5 - 40	-	-	30	
Minimum pulse width		0.5 - 40	-	-	0.1	µs
rise/fall time ⁹		0.5 - 40	-	50	-	ns
Pulse duty cycle for pulse profiling ⁶		0.5 - 40	0.1	-	99.9	%
DC current	@ Ethernet disabled	0.5 - 40	-	450	500	mA
	@ Ethernet enabled ¹⁰		-	540	700	
Trigger in voltages	Logic High	-	2.7	-	5.0	V
	Logic Low	-	0	-	0.6	
Trigger out voltages @ High impedance load	Logic High	-	3	-	5.2	
	Logic Low	-	0	-	0.3	
Video out @ 50 Ω load		Output voltage	-	0.5	-	2.2

¹ Maximum continuous safe operational power limit: +23 dBm.

² Tested with CW signal

³ Power uncertainty is specified for default sample period of 80 µs.

⁴ At temperatures below 15deg, over frequency 20-40GHz, accuracy degrades when power is less than -15dBm.

⁵ Internal trigger can be set to from -15 to +15 dBm in 5 dB increments.

⁶ As sample period increases above 80 µs resolution will decrease. To get high resolution of the pulse while maintaining large sample period use the 'Zoom on Pulse' function in Pulse profiling (see page 6 for details).

⁷ Max sample rate is measured in millions of samples per second (msp/s). With sample periods greater than 80 µs the sample rate will be reduced to allow covering the full sample period.

⁸ Internal video BW is selectable between CW, 1.5, 5 & 10 MHz.

⁹ While the sensor's internal rise time is 50 ns, this does not mean a signal with a rise time of 50 ns can be accurately measured. See page 4 for details.

¹⁰ When Ethernet control is enabled, it is recommended to use an external power supply (USB-AC/DC-5+ or equiv), a powered hub, or USB 3.0/3.1 port, as USB 2.0 ports are specified to supply 500mA load and thus may not be able to supply the required current.

Absolute Maximum Ratings

Parameter	Ratings
Operating Temperature	10°C to 50°C
Storage Temperature	-30°C to 70°C
DC Voltage at RF port	5 V
Trigger In	-0.3V to 5.5V
CW Power	+27 dBm

Connections

RF Input	(2.92 mm Male)
Trigger In	(SMB-Male)
Trigger Out	(SMB-Male)
USB Port	(USB type B female)
Network (Ethernet/LAN)	(RJ45 socket)

Outline Drawing (JL3257)

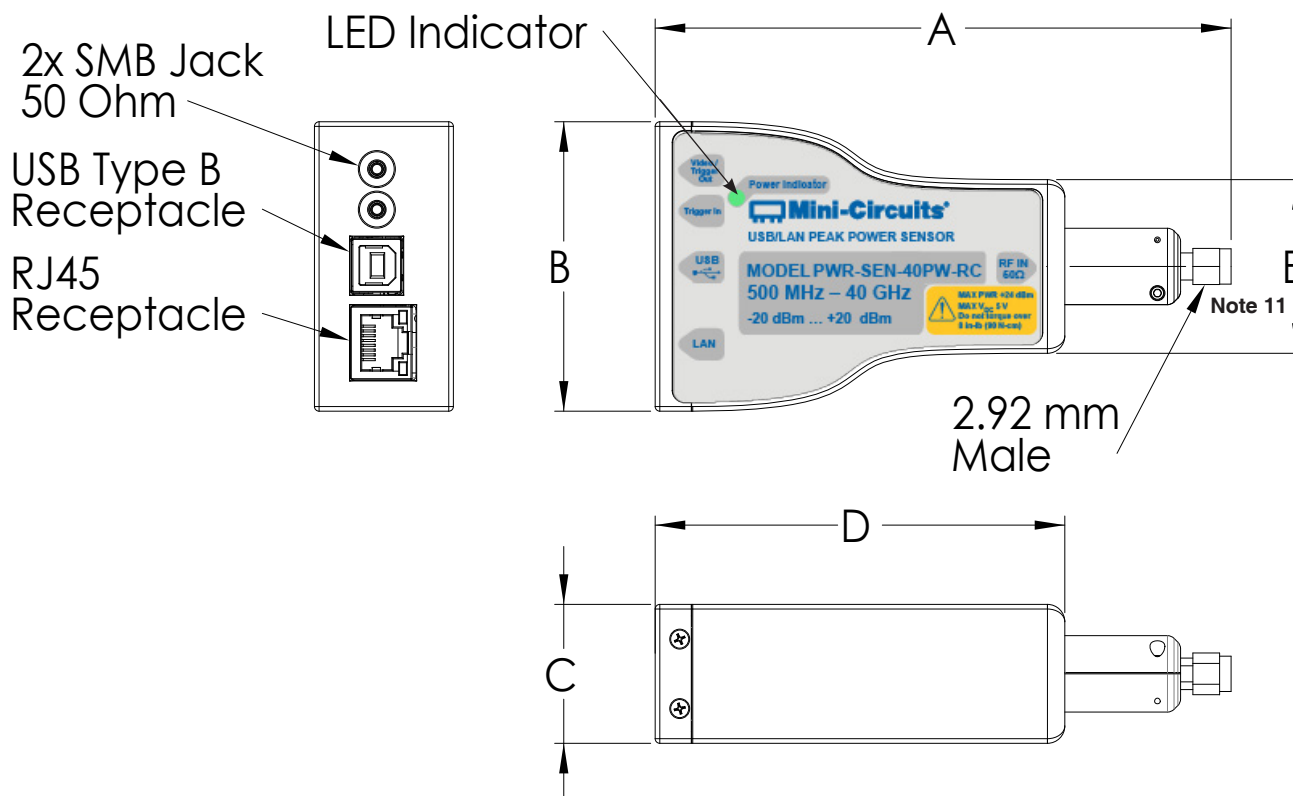

Outline Dimensions (inch / mm)

A	B	C	D	E	WT. GRAMS
4.97	2.50	1.20	3.54	1.5	260
126.3	63.5	30.5	89.9	38.1	

¹¹ Maximum torque 8 in-lb (90 N-cm).

Typical Performance Curves

UNCERTAINTY OF POWER MEASUREMENT
@ +25°C

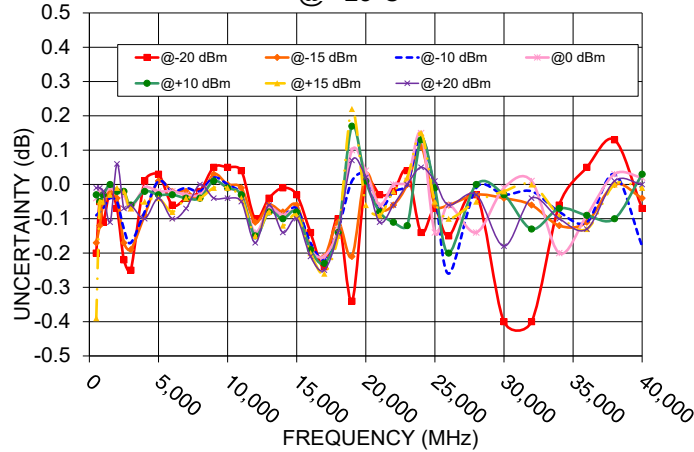

VSWR

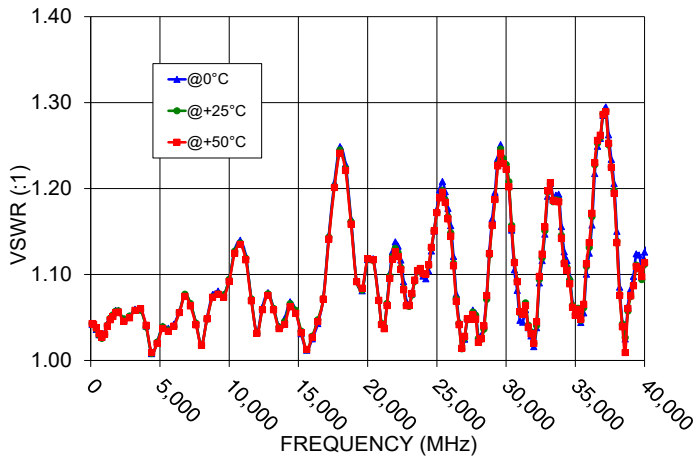

Rise/Fall time Measurement Error

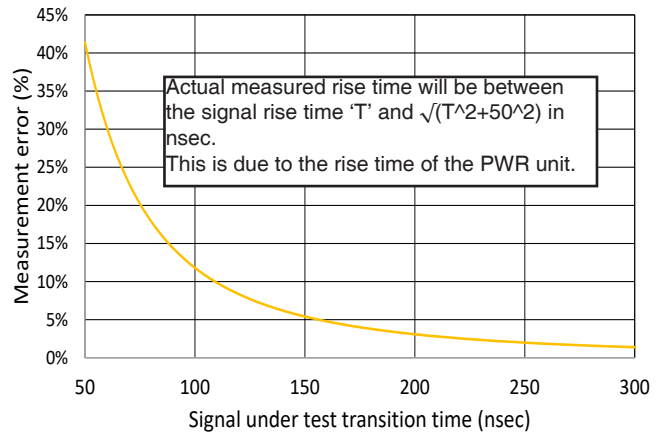

Software Specifications:

Software & Documentation Download:

- Mini-Circuits' full software and support package including user guide, Windows GUI, DLL files, programming manual and examples can be downloaded free of charge from <http://www.minicircuits.com/softwaredownload/pm.html>.
- Please contact testsolutions@minicircuits.com for support

Minimum System Requirements

Parameter	Requirements
Interface	USB HID or Ethernet (HTTP & Telnet)
System requirements	GUI: Windows 98 or later
	USB API (ActiveX & .Net) Windows 98 or later and programming environment with ActiveX or .NET support
	USB direct programming support Linux, Windows systems from Windows 98 up to Windows 10
	Ethernet Windows, Linux or Mac computer with a network port and Ethernet TCP/IP support
Hardware	Pentium® II or higher, RAM 256 MB
Control cable (supplied)	Power sensor to be used with the supplied USB cable only

Graphical User Interface (GUI) for Windows

Key Features:

- Set compensation frequency and monitor power measurement
- Configure measurement (offsets, relative power readings, averaging, set Video BW, etc.)
- Peak and average power measurement
- Pulse profiling (see [user guide](#) and page 6 for details)
- Internal and external trigger, Trigger and Video outputs
- Graphical pulse display with 'zoom on pulse' feature (see [user guide](#) and page 6 for details)
- Control multiple power sensors at once
- Schedule data recording

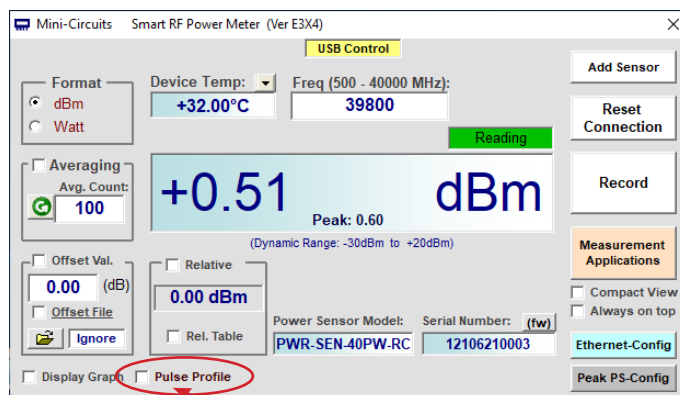

Enable pulse profiling and graphical pulse display, see page 6 for details

Application Programming Interface (API)

Windows Support:

- API DLL files exposing the full power sensor functionality
 - ActiveX COM DLL file for creation of 32-bit programs
 - .Net library DLL file for creation of 32 / 64-bit programs
- HTTP Get/Post and Telnet protocols use SCPI commands to provide full control.
- Supported by most common programming environments (refer to application note [AN-49-001](#) for summary of tested environments)

Linux Support:

- Full power sensor control in a Linux environment is achieved by way of USB interrupt commands.



Graphical User Interface - Pulse Profiling Features

- Set the sample period between 1µs and 1s to capture the pulse profile
- Select from 4 trigger options:
 1. Free – No trigger / free running measurements
 2. Internal – Detect and stabilise the measurements on the rising edge of the RF signal (at the level specified).
 3. External
 - a. Rising edge – Measurements are triggered on the rising edge of an external trigger signal
 - b. Falling edge – Measurements are triggered on the falling edge of an external trigger signal
- Enable external trigger / video output if required:
 - a. External trigger provides a TTL output on the rising edge of a pulse for synchronization with external measurement equipment
 - b. Video output allows wider bandwidth pulses to be recorded by external measurement equipment

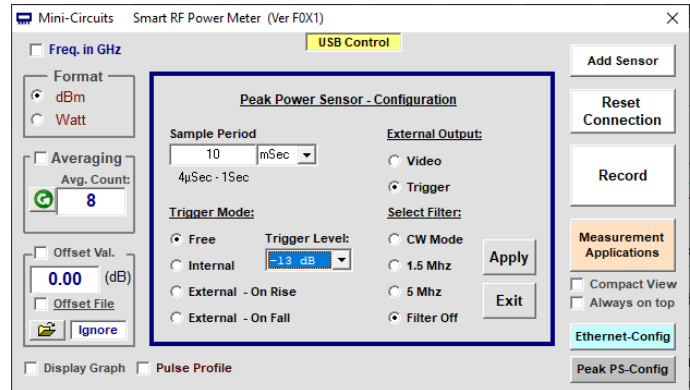

Fig 1: Main screen in Pulse Profiling configuration mode

The main pulse profile display shows the full sample period of the sensor in the time domain. Up to four markers can be set as required to measure power levels and calculate time / power deltas

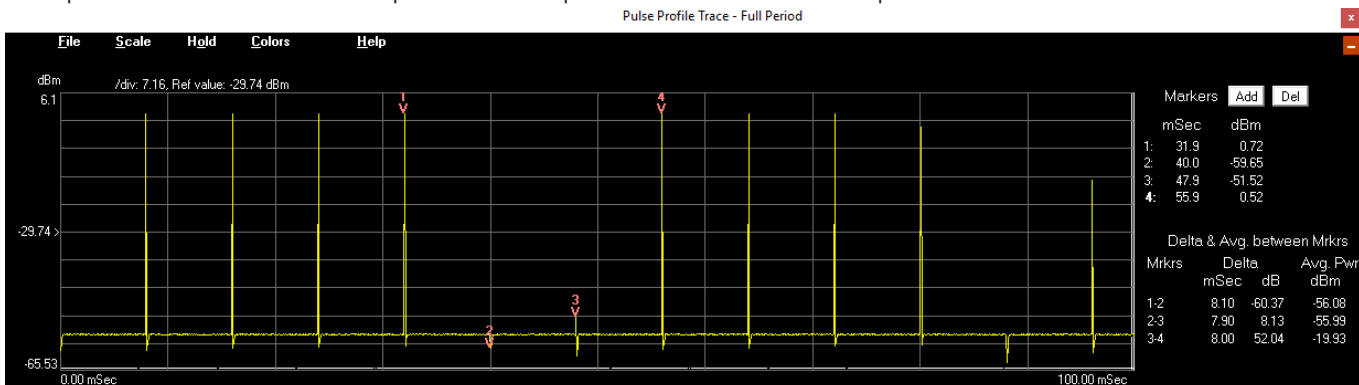

Fig 2: Graphical Pulse Profile - Full sample period

“Zoom on pulse” feature will automatically zoom on the first identified pulse and allows any portion of the pulse profile to be focused on / expanded in a second graphical display, simply by ‘right clicking’ and dragging the mouse cursor over relevant section of the profile.

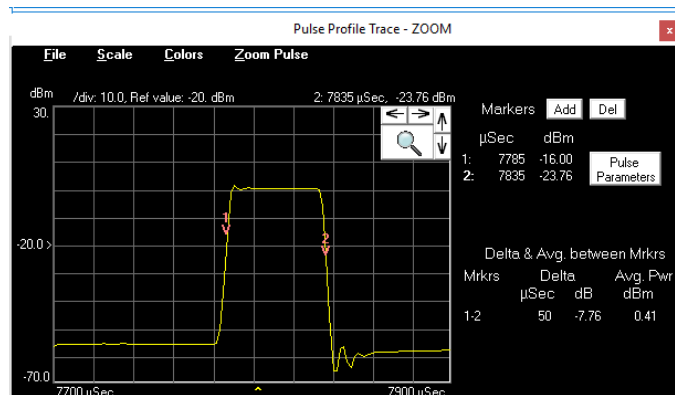

Fig 3: Graphical Pulse Profile - “Zoom on Pulse”

For signals with duty cycle greater than 99.9% or under 0.1% the automatic ‘zoom on pulse’ may not work - in such cases you can adjust the zoom window by clicking on the arrow icons to increment/decrement the trigger delay and span, or the magnifying glass to type in precise values

Parameter	Value
Pulse Width (mSec)	0.044
Pulse Period (mSec)	8.020
Duty Cycle (%)	0.55
Rise Time (µs)	3.54
Fall Time (µs)	3.54
Pulse Pwr (dBm)	0.75
Cycle Avg. (dBm)	-19.70
Crest Factor (dB)	20.45
Over Shoot (dB)	0.98

Fig 4: Calculated Pulse parameters

Full pulse parameters are calculated and displayed in tabular form, including peak / average power, pulse width / period, duty cycle, rise / fall time, crest factor and overshoot.

Note: If ‘zoom on pulse’ window is not showing the pulse signal calculated parameter may not be correct

Examples of pulse profiling for standard modulation types:

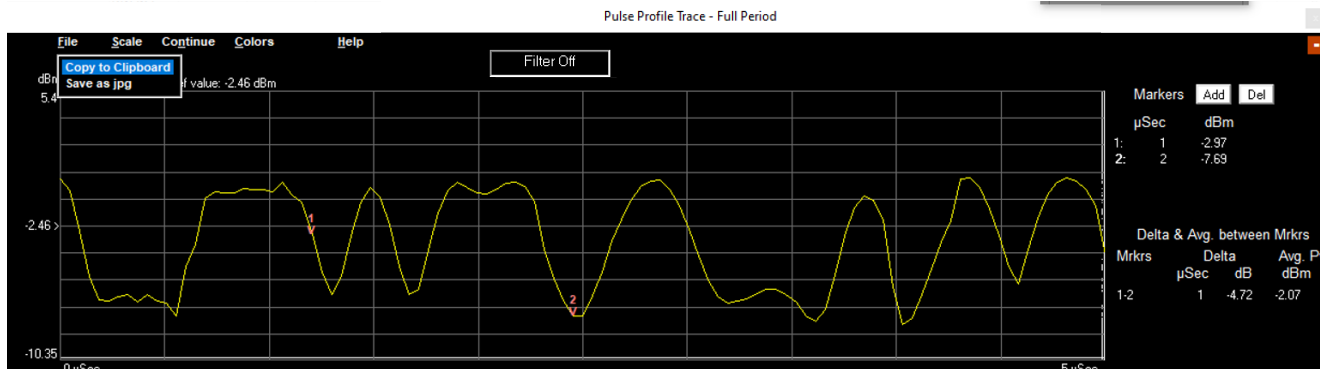

ASK @ 5Mps

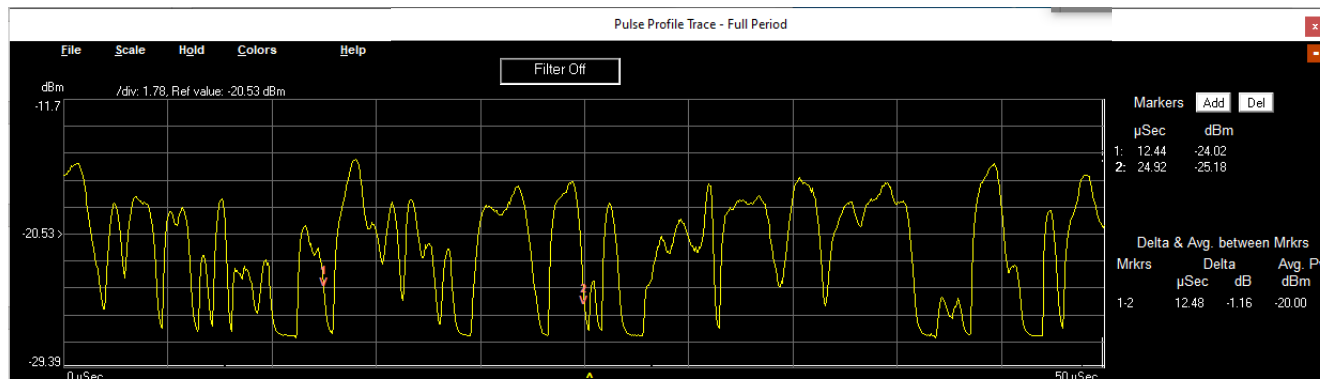

QAM256 in DECT setup, Gaussian filter@1.152Mps

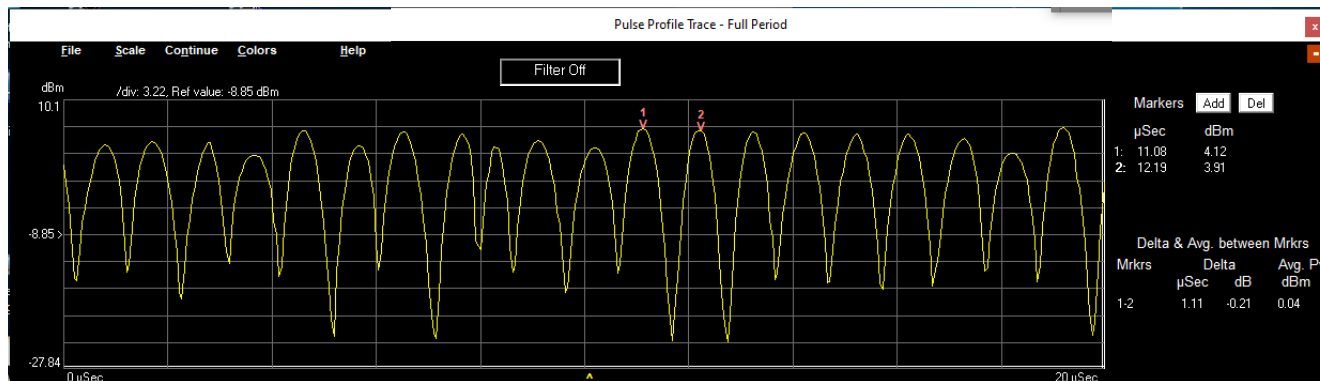

QPSK, QAM16 & QAM64 in LTE uplink setup(1.4 MHz channels,3.7 MHz offsets) 8 MHz clock

Connection diagrams

Connection diagram for USB control

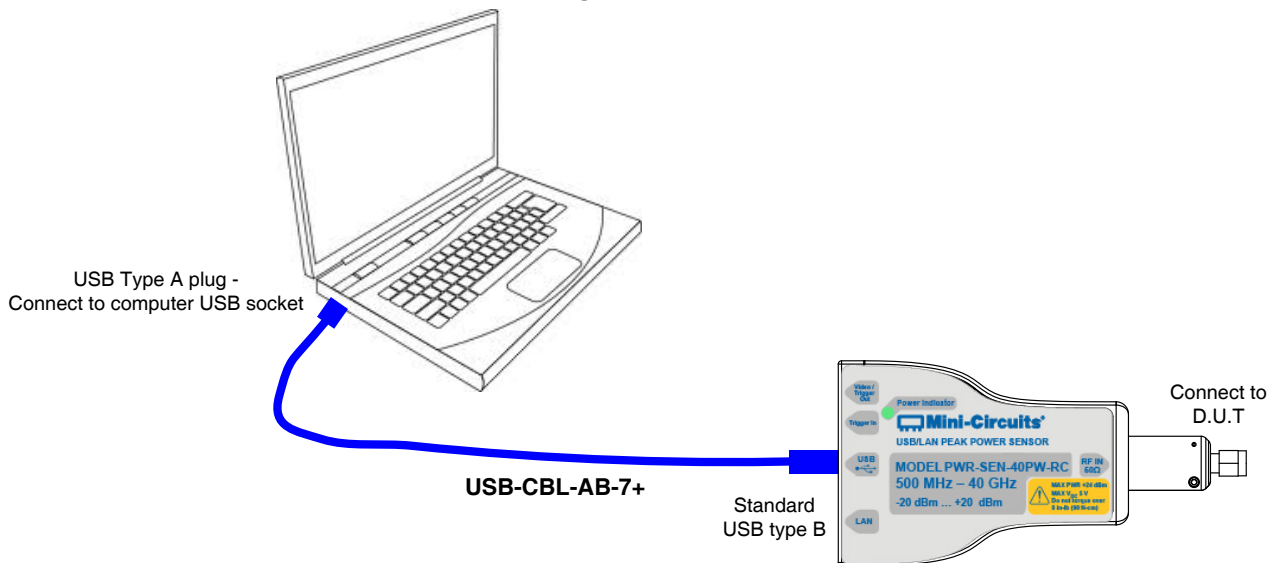

Connect USB-AC/DC-5 to mains power

Connection diagram for Ethernet control, using power adaptor

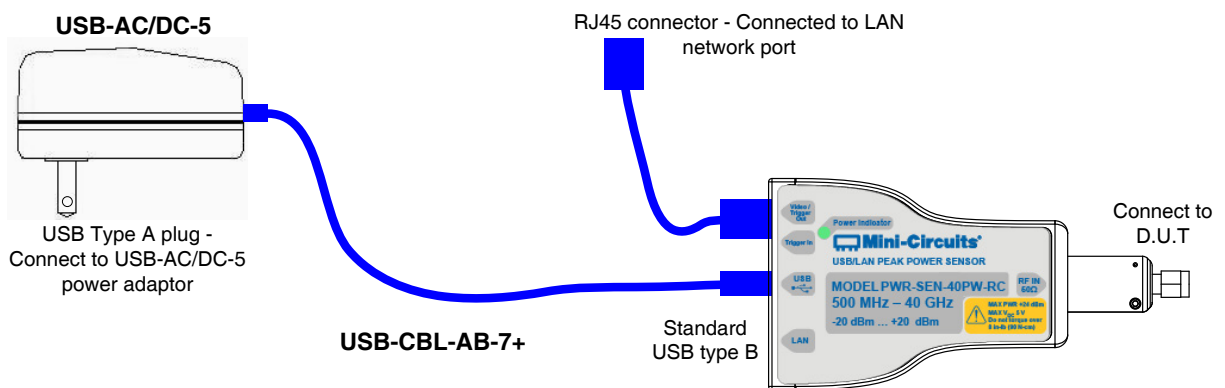

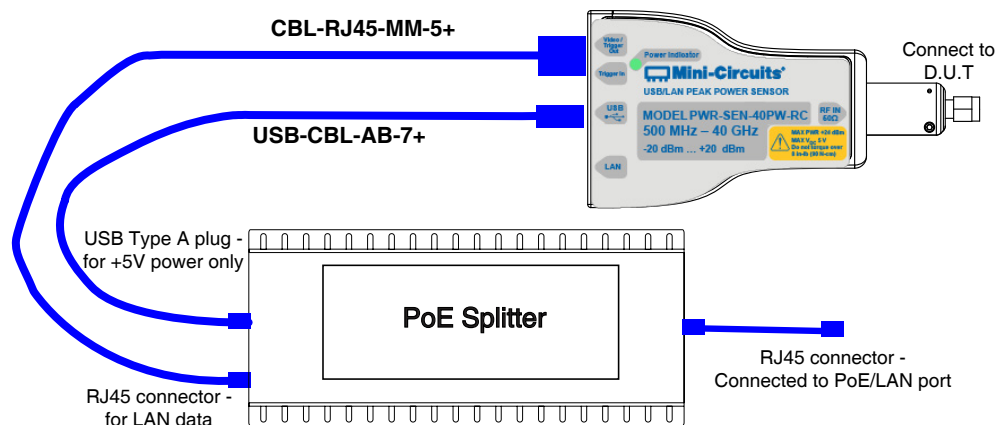

Connection diagram for Ethernet control, using PoE system

Note: Commercially available PoE splitter not supplied by Mini-Circuits



Ordering Information

Model	Description
PWR-40PW-RC	USB/Ethernet <i>Smart</i> Peak & Average Power Sensor

Included Accessories	Part No.	Description
	PWR-SEN-40PW-RC	Power Sensor Head
	USB-CBL-AB-7+	6.8 ft (2.1 m) USB Cable: USB type A(Male) to USB type B(Male)
	CBL-5FT-BMSMB+	5 ft (1.5 m) Trigger cable: BNC(male) to SMB(Female)

¹² Power Sensor to be used with the supplied control cable only.

Optional Accessories	Description
USB-AC/DC-5	AC/DC 5V _{DC} Power Adapter with US, EU, IL, UK, AUS, and China power plugs ^{13,14}
USB-CBL-AB-3+	2.7 ft (0.8 m) USB Cable: USB type A(Male) to USB type B(Male)
USB-CBL-AB-7+ (spare)	6.8 ft (2.1 m) USB Cable: USB type A(Male) to USB type B(Male)
CBL-RJ45-MM-5+	5 ft (1.5 m) Ethernet cable: RJ45(Male) to RJ45(Male) Cat 5E cable
CBL-5FT-BMSMB+(spare)	5 ft (1.5 m) Trigger cable: BNC(male) to SMB(Female)
NM-SF50+	N-Type Male to SMA Female Adapter.
NF-SF50+	N-Type Female to SMA Female Adapter
185F-KF+	1.85 mm Female to 2.92 Female Adapter.

¹³ Power plugs for other countries are also available, if you need a power plug for a country not listed in the table please contact testsolutions@minicircuits.com for support.

¹⁴ Power adaptor, powered hub or USB 3.0/3.1 port may be used to provide power when in Ethernet control, not needed in USB control.

Calibration	Description
CALSEN-40PW-RC	Calibration Service Click Here

Additional Notes

- A. Performance and quality attributes and conditions not expressly stated in this specification document are intended to be excluded and do not form a part of this specification document.
- B. Electrical specifications and performance data contained in this specification document are based on Mini-Circuit's applicable established test performance criteria and measurement instructions.
- C. The parts covered by this specification document are subject to Mini-Circuits standard limited warranty and terms and conditions (collectively, "Standard Terms"); Purchasers of this part are entitled to the rights and benefits contained therein. For a full statement of the Standard Terms and the exclusive rights and remedies thereunder, please visit Mini-Circuits' website at www.minicircuits.com/MCLStore/terms.jsp



USB/Ethernet Power Sensor

PWR-40PW-RC

Typical Performance Data

FREQ. (MHz)	VSWR (:1)		
	0°C	+25°C	+50°C
	500	1.03	1.03
550	1.03	1.03	1.03
600	1.03	1.03	1.03
700	1.03	1.03	1.03
800	1.03	1.03	1.03
1000	1.03	1.03	1.03
1200	1.04	1.04	1.04
1400	1.05	1.05	1.05
1600	1.05	1.05	1.05
1800	1.06	1.06	1.06
2500	1.05	1.05	1.05
3000	1.06	1.05	1.05
4000	1.04	1.04	1.04
5000	1.03	1.03	1.03
6000	1.04	1.04	1.04
7000	1.08	1.08	1.07
8000	1.02	1.02	1.02
9000	1.08	1.08	1.08
10000	1.09	1.09	1.09
11000	1.14	1.13	1.13
12000	1.03	1.03	1.03
13000	1.08	1.08	1.07
14000	1.05	1.05	1.04
15000	1.04	1.04	1.04
16000	1.03	1.03	1.03
17000	1.10	1.10	1.10
18000	1.25	1.25	1.24
19000	1.12	1.12	1.12
20000	1.12	1.12	1.12
21000	1.04	1.04	1.04
22000	1.14	1.13	1.13
23000	1.07	1.06	1.06
24000	1.10	1.10	1.10
25000	1.18	1.17	1.17
26000	1.16	1.15	1.14
27000	1.02	1.03	1.03
28000	1.03	1.03	1.02
29000	1.16	1.16	1.16
30000	1.23	1.23	1.22
31000	1.05	1.06	1.06
32000	1.02	1.02	1.02
33000	1.19	1.20	1.20
34000	1.16	1.15	1.14
35000	1.05	1.05	1.05
36000	1.12	1.13	1.14
37000	1.29	1.29	1.29
38000	1.15	1.14	1.14
38500	1.03	1.03	1.03
39000	1.08	1.07	1.08
39200	1.10	1.09	1.09
39400	1.12	1.11	1.11
39600	1.12	1.11	1.11
39800	1.11	1.09	1.10
40000	1.13	1.11	1.11

LINEARITY @ +25°C		
FREQ. (MHz)	(%)	
	@ 0 to 20 dBm	@ -20 to 0 dBm
500	-2.50%	0.46%
550	-3.17%	-0.23%
600	1.62%	-0.92%
700	-0.69%	-0.23%
800	-1.83%	-0.46%
1000	-0.69%	-6.67%
1200	0.46%	-1.37%
1400	-0.23%	2.33%
1600	-1.14%	-1.60%
1800	-1.14%	-5.81%
2500	-3.84%	0.46%
3000	-4.94%	0.46%
4000	-4.06%	-0.46%
5000	0.46%	0.69%
6000	0.69%	2.57%
7000	0.23%	0.93%
8000	-0.23%	-1.14%
9000	1.39%	2.09%
10000	1.86%	0.69%
11000	-0.69%	-0.69%
12000	1.39%	-0.69%
13000	0.93%	-0.23%
14000	0.93%	0.93%
15000	-0.46%	1.16%
16000	0.69%	0.69%
17000	-0.46%	0.23%
18000	-5.16%	2.80%
19000	0.46%	3.51%
20000	-0.69%	0.69%
21000	0.00%	0.93%
22000	-1.60%	1.62%
23000	-1.14%	0.69%
24000	-6.46%	-1.14%
25000	2.80%	-3.17%
26000	-3.62%	-0.46%
27000	5.68%	-3.39%
28000	4.95%	-3.17%
29000	-7.96%	0.46%
30000	-7.32%	1.39%
31000	-2.50%	1.16%
32000	-8.17%	0.69%
33000	-8.17%	1.39%
34000	6.17%	-2.28%
35000	0.69%	0.69%
36000	3.28%	1.16%
37000	2.33%	-2.28%
38000	4.95%	0.93%
38500	-0.46%	1.39%
39000	-0.92%	1.16%
39200	0.69%	0.46%
39400	0.69%	0.23%
39600	-0.23%	0.00%
39800	-0.46%	1.86%
40000	0.00%	0.00%

Notes

- A. Performance and quality attributes and conditions not expressly stated in this specification document are intended to be excluded and do not form a part of this specification document.
- B. Electrical specifications and performance data contained in this specification document are based on Mini-Circuit's applicable established test performance criteria and measurement instructions.
- C. The parts covered by this specification document are subject to Mini-Circuits standard limited warranty and terms and conditions (collectively, "Standard Terms"); Purchasers of this part are entitled to the rights and benefits contained therein. For a full statement of the Standard Terms and the exclusive rights and remedies thereunder, please visit Mini-Circuits' website at www.minicircuits.com/MCLStore/terms.jsp



USB Power Sensor

PWR-40PW-RC

Typical Performance Data

FREQ. (MHz)	UNCERTAINTY OF POWER MEASUREMENT								
	@ 25° C								
	(dBm)								
	@ -20 dBm	@ -15 dBm	@ -10 dBm	@ -5 dBm	@ 0 dBm	@ 5 dBm	@ 10 dBm	@ 15 dBm	@ 20 dBm
500	-0.20	-0.17	-0.09	-0.03	-0.04	-0.03	-0.03	-0.39	-0.01
550	-0.10	-0.01	-0.03	0.01	0.01	-0.02	-0.02	-0.17	-0.01
600	-0.17	-0.03	-0.07	-0.05	-0.03	-0.04	-0.03	-0.05	-0.02
700	0.02	-0.01	-0.02	0.01	-0.05	-0.04	-0.03	-0.05	-0.01
800	0.00	-0.01	-0.06	-0.03	-0.05	-0.06	-0.05	-0.05	-0.01
1000	-0.05	-0.12	-0.08	-0.02	-0.02	-0.06	-0.05	-0.05	-0.01
1200	-0.01	-0.13	-0.09	-0.07	-0.04	-0.06	-0.07	-0.08	-0.03
1400	-0.13	-0.13	-0.08	-0.03	-0.05	-0.06	-0.05	-0.07	-0.03
1600	-0.15	-0.11	-0.09	-0.06	-0.06	-0.07	-0.06	-0.06	-0.16
1800	-0.11	-0.06	-0.07	-0.01	-0.03	-0.03	-0.03	-0.05	-0.02
2500	-0.03	0.01	0.00	0.03	0.00	0.00	0.01	-0.02	0.30
3000	0.02	-0.01	-0.01	0.02	-0.02	0.00	0.00	-0.01	-0.01
4000	-0.05	-0.07	-0.06	-0.05	-0.07	-0.04	-0.03	-0.04	-0.01
5000	0.00	-0.03	-0.05	-0.02	-0.06	-0.03	-0.02	-0.04	-0.05
6000	-0.02	-0.02	-0.04	0.00	-0.01	-0.01	0.00	-0.03	-0.11
7000	-0.07	-0.06	-0.07	-0.02	-0.05	-0.04	-0.03	-0.05	-0.18
8000	-0.11	-0.08	-0.07	-0.04	-0.06	-0.06	-0.06	-0.06	0.01
9000	-0.10	-0.05	-0.06	0.00	-0.02	-0.03	-0.02	-0.04	0.01
10000	-0.08	-0.03	-0.03	0.02	-0.03	-0.02	0.00	0.00	0.23
11000	-0.07	-0.04	-0.05	-0.02	-0.02	0.00	-0.02	-0.01	0.06
12000	0.49	-0.03	-0.19	-0.20	-0.21	-0.25	-0.26	-0.32	-0.38
13000	-0.18	-0.16	-0.10	-0.02	0.00	0.00	-0.01	0.03	-0.03
14000	-0.25	-0.19	-0.13	-0.04	-0.05	-0.04	-0.02	-0.02	-0.05
15000	-0.20	-0.18	-0.14	-0.05	-0.05	-0.04	-0.02	-0.03	-0.06
16000	-0.22	-0.17	-0.13	-0.05	-0.03	-0.02	-0.02	-0.02	-0.07
17000	-0.22	-0.15	-0.14	-0.04	-0.05	-0.03	-0.04	-0.04	-0.07
18000	-0.21	-0.16	-0.12	-0.04	-0.05	-0.04	-0.03	0.00	-0.04
19000	-0.20	-0.19	-0.14	-0.04	-0.05	-0.05	-0.04	-0.04	-0.07
20000	-0.38	-0.23	-0.18	-0.11	-0.10	-0.09	-0.07	-0.06	-0.10
21000	-0.25	-0.19	-0.17	-0.08	-0.07	-0.09	-0.06	-0.07	-0.06
22000	-0.22	-0.13	-0.11	-0.01	0.00	-0.01	0.00	0.00	-0.02
23000	-0.22	-0.13	-0.11	-0.02	-0.02	-0.02	-0.01	0.00	-0.02
24000	-0.25	-0.19	-0.15	-0.06	-0.06	-0.06	-0.04	-0.04	-0.08
25000	-0.20	-0.18	-0.15	-0.08	-0.05	-0.06	-0.05	-0.04	-0.08
26000	-0.23	-0.18	-0.13	-0.04	-0.05	-0.04	-0.04	-0.02	-0.03
27000	-0.16	-0.14	-0.10	-0.02	0.00	-0.02	-0.01	-0.01	-0.03
28000	-0.09	-0.09	-0.07	-0.01	0.01	0.00	0.03	0.01	-0.02
29000	-0.05	-0.08	-0.05	0.03	0.03	0.03	0.02	0.02	-0.02
30000	-0.07	-0.07	-0.05	0.03	0.03	0.02	0.00	-0.01	-0.06
31000	0.01	-0.09	-0.08	-0.04	-0.01	-0.02	-0.02	-0.05	-0.10
32000	-0.17	-0.04	0.02	0.02	0.01	0.03	0.03	0.04	0.03
33000	-0.10	-0.01	0.04	0.03	0.03	0.03	0.01	0.01	-0.01
34000	-0.04	0.00	0.03	0.02	0.02	0.02	0.00	0.00	0.01
35000	-0.01	0.02	0.04	0.04	0.04	0.02	0.03	0.02	0.01
36000	0.02	0.05	0.06	0.06	0.04	0.04	0.05	0.03	0.04
37000	0.08	0.05	0.05	0.05	0.04	0.03	0.03	0.03	0.01
38000	0.04	0.02	0.02	0.03	0.01	0.01	0.01	0.01	0.00
38500	0.01	0.00	0.00	-0.01	-0.01	-0.02	-0.01	-0.02	-0.05
39000	0.02	0.01	-0.01	0.00	-0.01	-0.02	-0.02	-0.02	-0.03
39200	0.03	0.01	0.01	0.00	-0.02	-0.02	-0.03	-0.04	-0.04
39400	0.01	0.01	-0.01	-0.01	-0.01	-0.02	-0.03	-0.05	-0.04
39600	-0.02	-0.02	-0.03	-0.03	-0.04	-0.05	-0.05	-0.07	-0.08
39800	-0.02	-0.02	-0.03	-0.02	-0.04	-0.06	-0.06	-0.06	-0.10
40000	-0.01	0.00	-0.01	-0.01	-0.03	-0.03	-0.03	-0.05	-0.08

Notes

- A. Performance and quality attributes and conditions not expressly stated in this specification document are intended to be excluded and do not form a part of this specification document.
- B. Electrical specifications and performance data contained in this specification document are based on Mini-Circuit's applicable established test performance criteria and measurement instructions.
- C. The parts covered by this specification document are subject to Mini-Circuit's standard limited warranty and terms and conditions (collectively, "Standard Terms"); Purchasers of this part are entitled to the rights and benefits contained therein. For a full statement of the Standard Terms and the exclusive rights and remedies thereunder, please visit Mini-Circuit's website at www.minicircuits.com/MCLStore/terms.jsp



USB Power Sensor

PWR-40PW-RC

Typical Performance Curves

VSWR

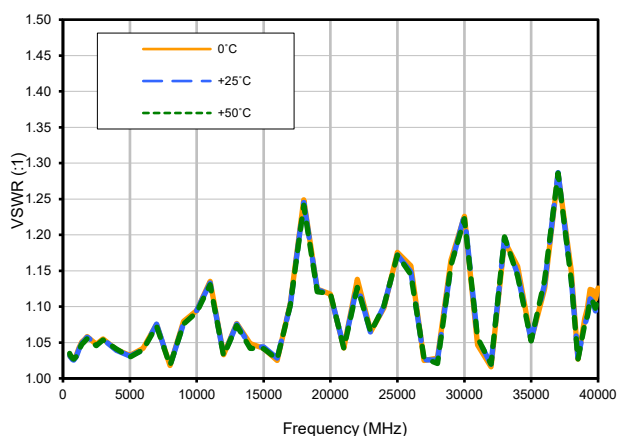

UNCERTAINTY OF POWER MEASUREMENT @ 25°C

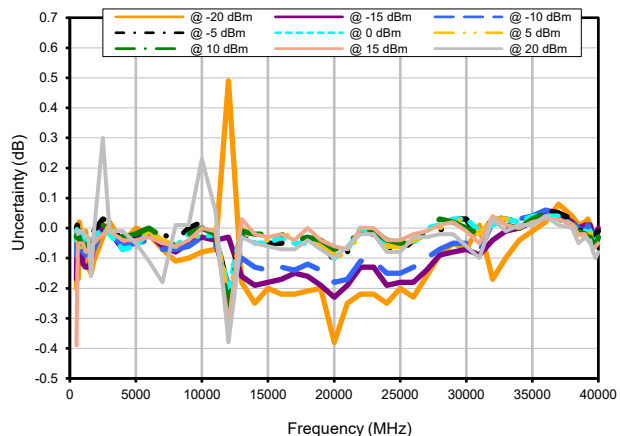

LINEARITY @ 25°C

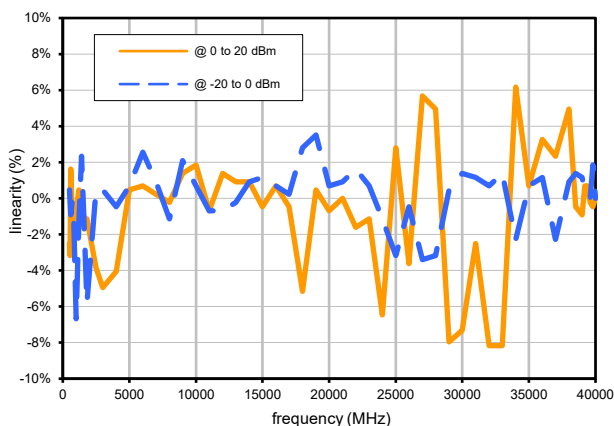

Notes

- A. Performance and quality attributes and conditions not expressly stated in this specification document are intended to be excluded and do not form a part of this specification document.
- B. Electrical specifications and performance data contained in this specification document are based on Mini-Circuit's applicable established test performance criteria and measurement instructions.
- C. The parts covered by this specification document are subject to Mini-Circuit's standard limited warranty and terms and conditions (collectively, "Standard Terms"); Purchasers of this part are entitled to the rights and benefits contained therein. For a full statement of the Standard Terms and the exclusive rights and remedies thereunder, please visit Mini-Circuit's website at www.minicircuits.com/MCLStore/terms.jsp



Case Style

JL

Outline Dimensions

JL3257

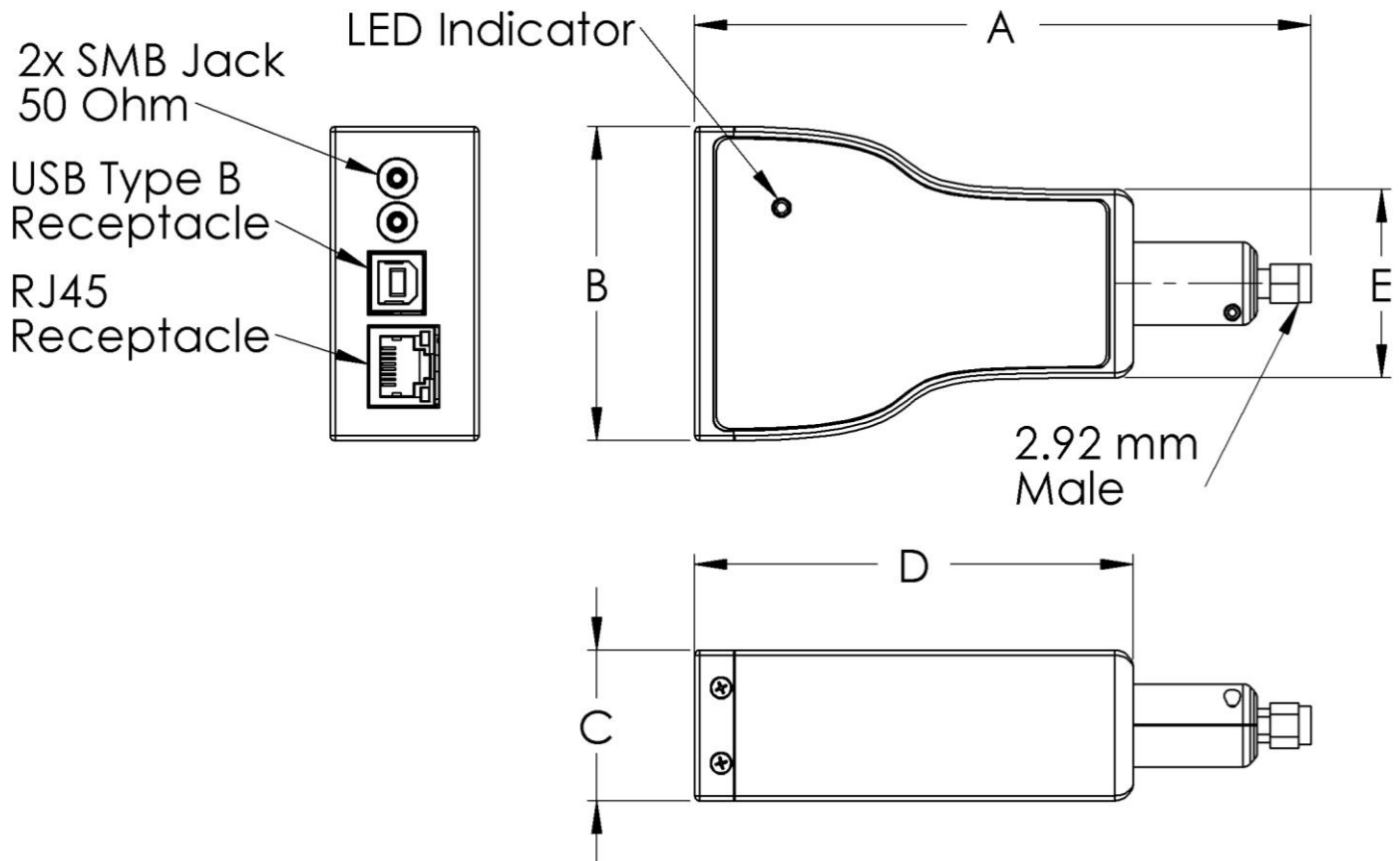

CASE#	A	B	C	D	E	WT. GRAMS
JL3257	4.97 (126.3)	2.50 (63.5)	1.20 (30.5)	3.54 (89.9)	1.50 (38.1)	260

Dimensions are in inches (mm). Tolerances: 2 Pl. $\pm .03$; 3 Pl. $\pm .015$

Notes:

1. Case material: Nickel Plated Aluminum Alloy.

 **Mini-Circuits**[®]

Distribution Centers NORTH AMERICA 800-654-7949 • 417-335-5935 • Fax 417-335-5945 • EUROPE 44-1252-832600 • Fax 44-1252-837010

Mini-Circuits ISO 9001 & ISO 14001 Certified

INTERNET <http://www.minicircuits.com>

P.O. Box 350166, Brooklyn, New York 11235-0003 (718) 934-4500 Fax (718) 332-4661



Environmental Specifications **ENV50**

All Mini-Circuits products are manufactured under exacting quality assurance and control standards, and are capable of meeting published specifications after being subjected to any or all of the following physical and environmental test.

Specification	Test/Inspection Condition	Reference/Spec
Operating Temperature	-0° to 50° C Ambient Environment	Individual Model Data Sheet
Storage Temperature	-30° to 70° C Ambient Environment	Individual Model Data Sheet
Operating and Storage Humidity	5% to 85% RH (non-condensing)	Ambient
Bench Handling Test	Bench Top Tip 45° & Drop	MIL-PRF-28800F
Transit Drop Test	Free Fall Drop, 20 cm (7.9 inches)	MIL-PRF-28800F Class 3