



## THE BIG DEAL

- Trace modulation & pulse profiles with resolution down to 13 ns
- Measurement of modulated signals up to 30 MHz bandwidth
- Up to 80 dB power measurement range
- 80M samples per second
- Integrated LCD display for quick power readings

## APPLICATIONS

- 5G FR1, WiFi 6E, Bluetooth device testing
- Analysis of ASK, FSK, OFDM, QAM, LTE modulation
- X & Ku band pulsed radar testing
- Signal level calibration



Generic photo used for illustration purposes only.

## PRODUCT OVERVIEW

Mini-Circuits' PWR-18PWHS-RC peak & average power sensor operates from 50 MHz to 18 GHz with an industry leading measurement range down to -40 dBm in peak mode and -60 dBm in average mode. The 80 Msps sample rate with internal buffer enables up to 120k complete measurements per second. With up to 30 MHz video bandwidth, complex analysis and profiling of pulsed and modulated inputs is possible down to 13 ns resolution.

The compact package includes a rubberized outer case for protection and portability, N-type RF input connector, integrated LCD screen, SMB trigger input / output options and USB / Ethernet control.

The included measurement software for Windows walks the user through the power sensor settings, displays the current measurements and provides powerful data recording and export capabilities. A full API for Windows is also provided, with programming instructions and examples for Windows and Linux systems to set up automated power measurements in a range of common programming environments.

Mini-Circuits has a wide range of high-performance power sensors available on our [website](#). Consider the [PWR-18RMS-RC](#) RMS power sensor for applications involving wider modulation bandwidths (>30 MHz) or multi-tone signals.

## KEY FEATURES

Feature	Advantages
Peak & average sensor with 80 Msps rate	Capture pulsed and modulated signals with exceptionally high data resolution and speed for peak, average and statistical analysis of inputs.
External trigger controls	Trigger in and out ports support precise synchronization with external test equipment, allowing capture of irregular signal patterns & pulses.
30 MHz selectable video bandwidth	30 MHz video bandwidth permits measurement and analysis of pulses with rise / fall times as low as 13 ns. Set the internal video filter with lower video bandwidths to reduce noise when this resolution is not required for the measurement at hand.
Video output port	Use in ALC (automatic level control) loops or observe the modulated signal directly on an oscilloscope for highest bandwidth.

### Trademarks:

Windows is a registered trademark of Microsoft Corporation in the United States and other countries ; Linux is a registered trademark of Linus Torvalds ; Pentium is a registered trademark of Intel Corporation. Neither Mini-Circuits nor the Mini-Circuits products are affiliated with or endorsed by the owners of the referenced trademarks. Mini-Circuits and the Mini-Circuits logo are registered trademarks of Scientific Components Corporation.



### ELECTRICAL SPECIFICATIONS, 25°C<sup>1,2</sup>

Parameter	Conditions	Frequency (GHz)	Min.	Typ.	Max.	Unit
Frequency Range	-	-	0.05	-	18	GHz
Input Power Range	Average Power Measurement	0.05 - 18	-60	-	+20	dBm
	Peak Power Measurement		-40	-	+20	
Uncertainty of Power Measurement, +25°C <sup>3</sup>	-60 to -50 dBm (Avg mode)	0.05 - 18	-	±0.2	±0.8	dB
	-50 to -30 dBm (Avg mode)		-	±0.2	±0.5	
	-40 to -30 dBm (Peak mode)		-	±0.2	±0.8	
	-30 to +20 dBm (Peak mode)		-	±0.2	±0.5	
Uncertainty of Power Measurement, 0°C to +50°C <sup>3</sup>	-60 to -50 dBm (Avg mode)	0.05 - 18	-	±0.5	-	dB
	-50 to -30 dBm (Avg mode)		-	±0.3	-	
	-40 to -30 dBm (Peak mode)		-	±0.5	-	
	-30 to +20 dBm (Peak mode)		-	±0.3	-	
Return Loss	-	0.05 - 18	18	21	-	dB
Linearity	-	0.05 - 18	-	3	-	%
Measurement Resolution	-	0.05 - 18	0.01	-	-	dB
Averaging Range	-	0.05 - 18	1	-	999	-
Sample Period	Full Sampling Rate	0.05 - 18	0.001	-	0.025	ms
	Reduced Sampling Rate <sup>4</sup>	0.05 - 18	-	-	1,000	
Measurement Rate <sup>5</sup> (including typical USB delays)	Sample Period= 1 μs	0.05 - 18	-	500	-	per sec
Measurement Rate <sup>5</sup> (Buffered + Free Trigger mode)	Sample Period= 1 μs	0.05 - 18	-	120,000	-	per sec
Sample Rate <sup>6</sup>	Sample Period ≤ 25 μs	0.05 - 18	-	-	80	Msp/s
Time Base Accuracy	-	-	-	-	50	ppm
Video Bandwidth <sup>7</sup>	-	0.05 - 18	-	-	30	MHz
Minimum Pulse Width	-	0.05 - 18	-	-	70	ns
Rise/Fall Time <sup>8</sup>	-	0.05 - 18	-	13	-	ns
Pulse Duty Cycle for Pulse Profiling	-	0.05 - 18	0.1	-	99.9	%
DC Current (I <sub>DC</sub> ) <sup>9</sup>	Ethernet disabled	0.05 - 18	-	475	550	mA
	Ethernet enabled		-	600	650	
Internal Trigger Accuracy <sup>10</sup>	-	0.05 - 18	-	0.5	-	dB
Trigger In	Logic Low	-	0	-	0.6	V
	Logic High	-	2.7	-	5.5	
Trigger Out <sup>11</sup> (into high impedance load)	Logic Low	-	0	-	0.3	
	Logic High	-	2.7	-	3.3	
Video Out @ 50 Ω load	Output Voltage	-	0	-	0.7	

- All specifications after 30 minutes warmup time and zeroing.
- Maximum continuous safe operational power limit: +23 dBm.
- Tested with CW signal and default sample period. For Sample period < (10 x Signal period), maintain Sample period = (N x Signal period). The sensor automatically switches from Peak to Average mode for signals below -30 to -40 dBm. Peak and average measurements are available above this threshold while only average measurements are possible below.
- As sample period increases above 25 μs resolution will decrease. To get high resolution of the pulse while maintaining large sample period use the "zoom on pulse" function in pulse profiling (see page 7 for details).
- The number of complete measurements taken per second with the specified sample period. Buffered mode captures multiple sequential measurements within the sensor for later retrieval / analysis.
- The rate at which the sensor captures discrete samples over the specified sample period. With sample periods greater than 25 μs the sample rate will be reduced to allow covering the full sample period.
- Video bandwidth can be set to 1.5 MHz, 5 MHz or OFF (~30 MHz) for Peak mode, or switched to Average mode.
- The minimum rise/fall time (measured at 10% to 90% i.e. 0.5 to 10 dBc) or resolution that can be observed in a pulsed and modulated signal.
- It is recommended to use USB 3.0/3.1 port, a powered hub, or an external power supply (USB-AC/DC-5 or equivalent) in order to supply the current.
- Internal trigger (relevant to peak mode) can be set from -40 to +20 dBm in 1 dB increments.
- Internal trigger functions (in & out) apply to Peak mode only. For Average mode, external or free running trigger should be used instead.



### TYPICAL PERFORMANCE GRAPHS

Uncertainty in Power Measurement @ Low Power Input

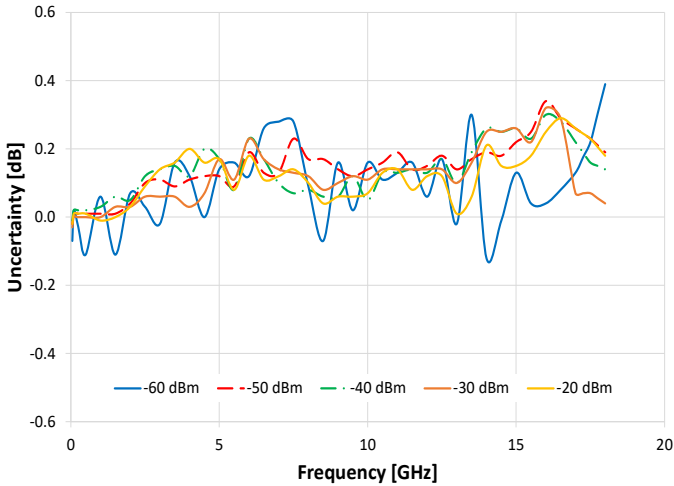

Uncertainty in Power Measurement @ High Power Input

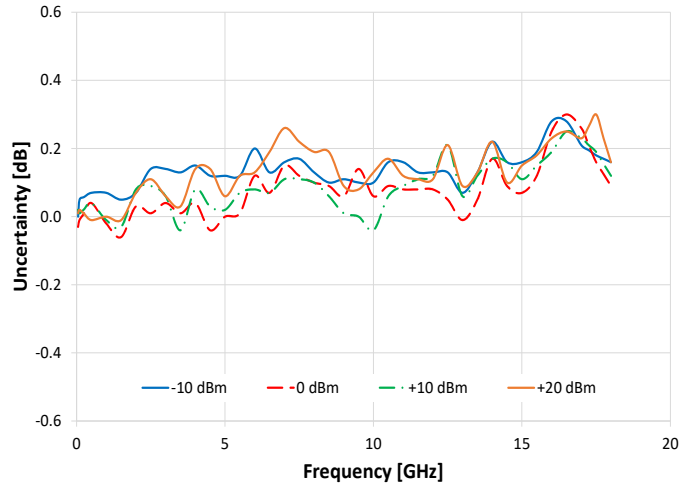

Linearity vs. Frequency

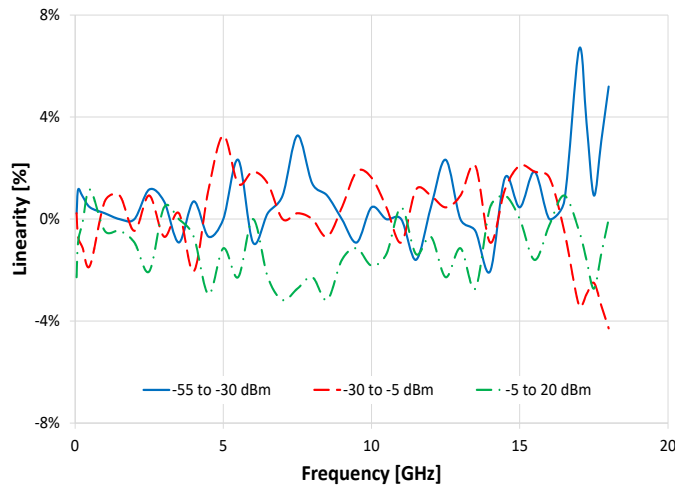

Return Loss vs. Frequency

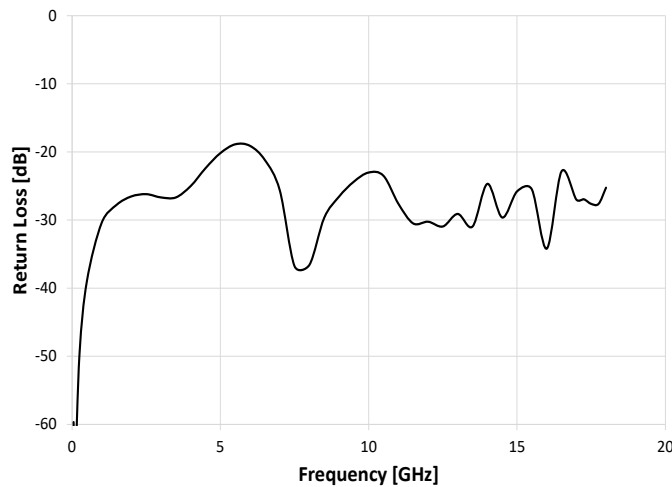

**CONTROL INTERFACES**

<b>Ethernet Control</b>	Supported Protocols	TCP / IP, HTTP, Telnet, DHCP, UDP (limited)
	Max Data Rate	100 Mbps (100 Base-T Full Duplex)
<b>USB Control</b>	Supported Protocols	HID (Human Interface Device) - High-speed
	Min Communication Time <sup>12</sup>	400 μs typ (full transmit/receive cycle)

12. USB Min Communication Time is based on the polling interval of the USB HID protocol (125 μs polling interval, 64 bytes per packet), medium CPU load and no other high-speed USB devices using the USB bus.

**SOFTWARE & DOCUMENTATION**

Mini-Circuits' full software and support package including user guide, Windows GUI, API, programming manual and examples can be downloaded free of charge (refer to the last page for the download path).

A comprehensive set of software control options is provided:

- GUI for Windows – Simple software interface for control via Ethernet and USB.
- Programming / automation via Ethernet:
  - Complete set of control commands which can be sent via any supported protocol.
  - Simple to implement in the majority of modern programming environments.
- Programming / automation via USB:
  - DLL files provide a full API for Windows with a set of intuitive functions which can be implemented in any programming environment supporting .Net Framework or ActiveX.
  - Direct USB programming is possible in any other environment (not supporting .Net or ActiveX).

Please contact [testsolutions@minicircuits.com](mailto:testsolutions@minicircuits.com) for support.

**MINIMUM SYSTEM REQUIREMENTS**

<b>GUI</b>	Windows 7 or later
<b>USB API DLL</b>	Windows 7 or later and programming environment with ActiveX or .NET support
<b>USB Direct Programming</b>	Linux, Windows 7 or later
<b>HTTP or Telnet</b>	Any computer with a network port and Ethernet-TCP/IP (HTTP or Telnet protocols) support
<b>Hardware</b>	Intel i3 (or equivalent) or later
<b>Control Cable</b>	Power sensor to be used with the supplied USB cable only



### GRAPHICAL USER INTERFACE (GUI) FOR WINDOWS - KEY FEATURES

- Connect via USB or Ethernet (HTTP, Telnet) to control the module.
- Control multiple power sensors at once.

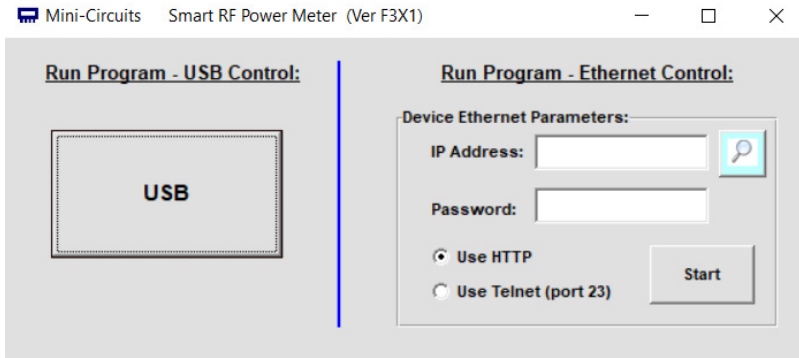

- Set compensation frequency and monitor power measurement.
- Configure measurement (offsets, relative power readings, averaging, set trigger mode, etc.).
- Zero the power sensor (recommended at the start of a new measurement session).
- Schedule data recording.

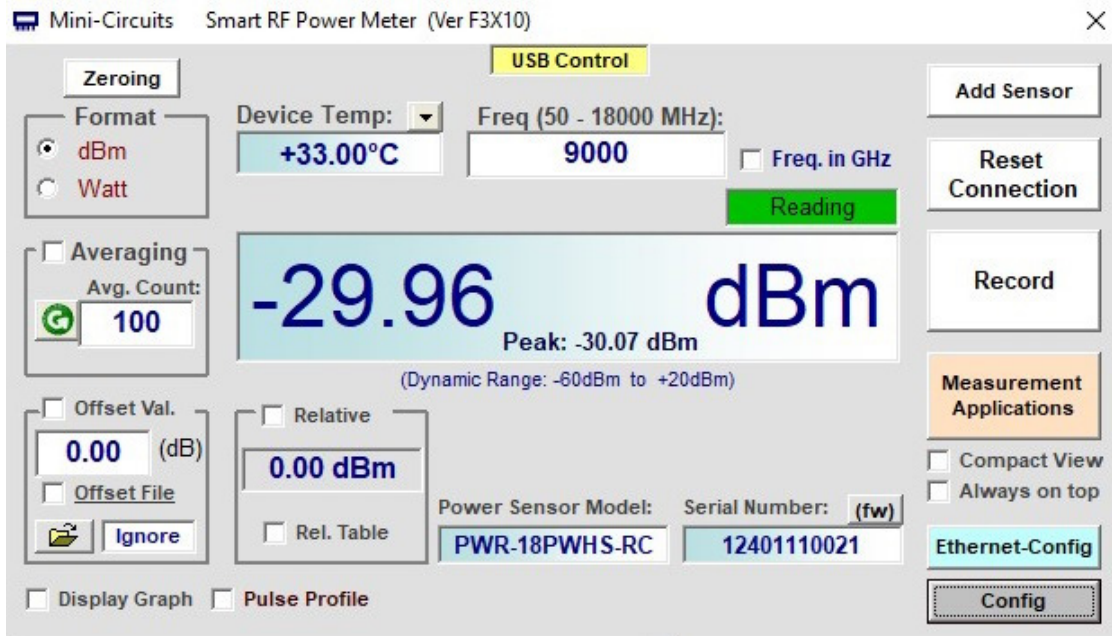



## PULSE PROFILING FEATURES CONFIGURATION SCREEN

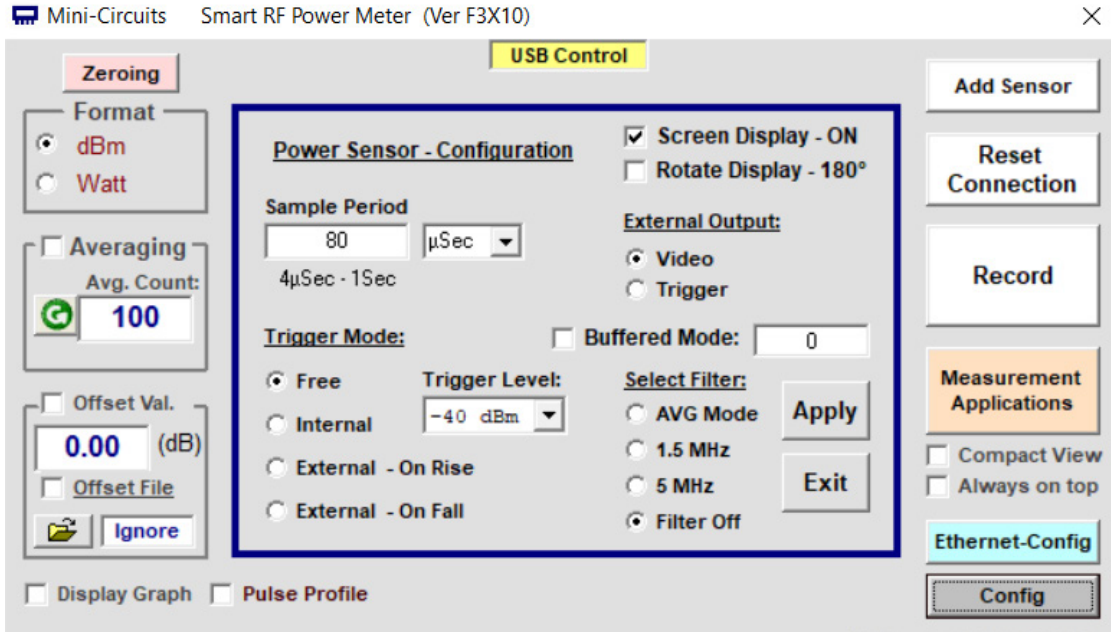

- Set the sample period (the time over which the sensor will average the power) between 100 μs and 1s.
- Select from 3 trigger options:
  1. Free – No trigger / free running measurements.
  2. Internal – Detect and stabilize the measurements on the rising edge of the RF signal (at the level specified).
  3. External On Rise – Measurements are triggered on the rising edge of an external trigger signal.
  4. External On Fall – Measurements are triggered on the falling edge of an external trigger signal.
- Select an external output type:
  1. Video – Output allows wider bandwidth pulses to be recorded by external measurement equipment.
  2. Trigger – Provides a TTL output on the rising edge of a pulse for synchronization with external measurement equipment.

## FULL SAMPLE PERIOD

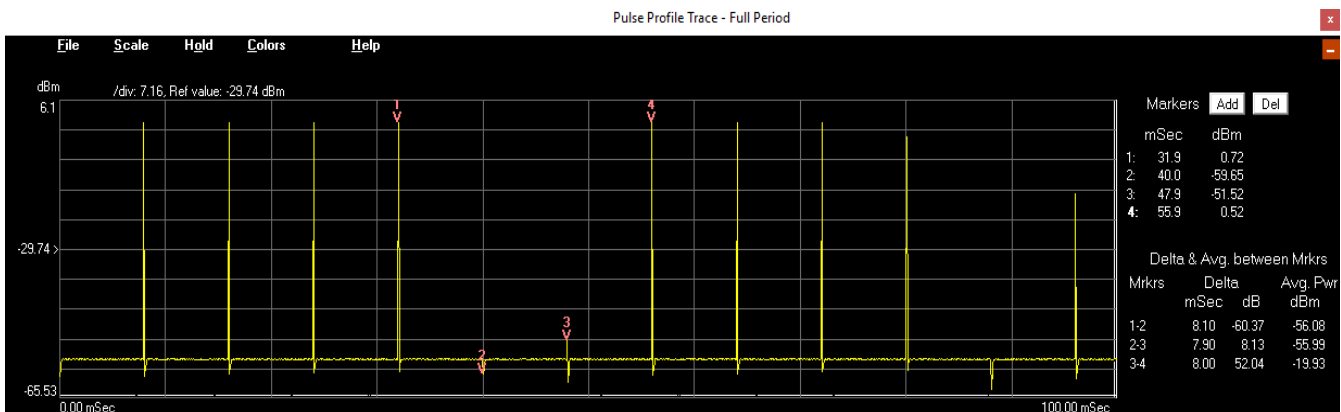

The main pulse profile display shows the full sample period of the sensor in the time domain. Up to four markers can be set as required to measure power levels and calculate time / power deltas.



## ZOOM ON PULSE

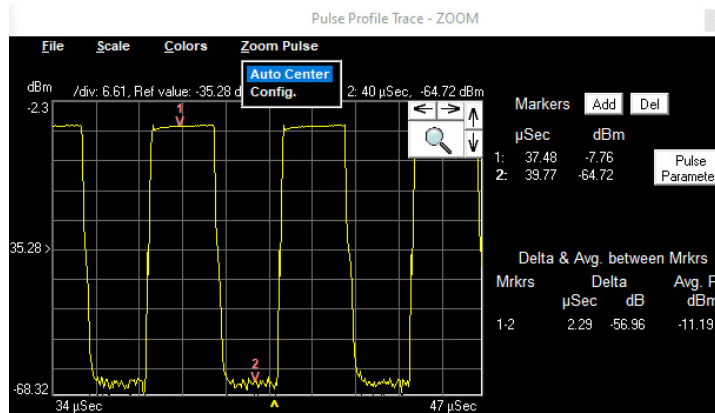

“Zoom on pulse” feature will automatically zoom on the first identified pulse and allows any portion of the pulse profile to be focused on / expanded in a second graphical display. Simply ‘right-click’ and drag the mouse cursor over relevant section of the profile.

For signals with duty cycle greater than 99.9% or under 0.1% the automatic “zoom on pulse” may not work. In such cases, you can adjust the zoom window by clicking on the arrow icons to increment/decrement the trigger delay and span, or the magnifying glass to type in precise values.

## CALCULATED PULSE PARAMETERS

Parameter	Value
Pulse Width (mSec)	0.044
Pulse Period (mSec)	8.020
Duty Cycle (%)	0.55
Rise Time (µs)	3.54
Fall Time (µs)	3.54
Pulse Pwr ( dBm)	0.75
Cycle Avg. ( dBm)	-19.70
Crest Factor (dB)	20.45
Over Shoot (dB)	0.98

Full pulse parameters are calculated and displayed in tabular form, including peak / average power, pulse width / period, duty cycle, rise / fall time, crest factor and overshoot.

**Note:** If “zoom on pulse” window is not showing, the pulse signal calculated parameter may not be correct.



## PULSE PROFILING EXAMPLES FOR STANDARD MODULATION TYPES

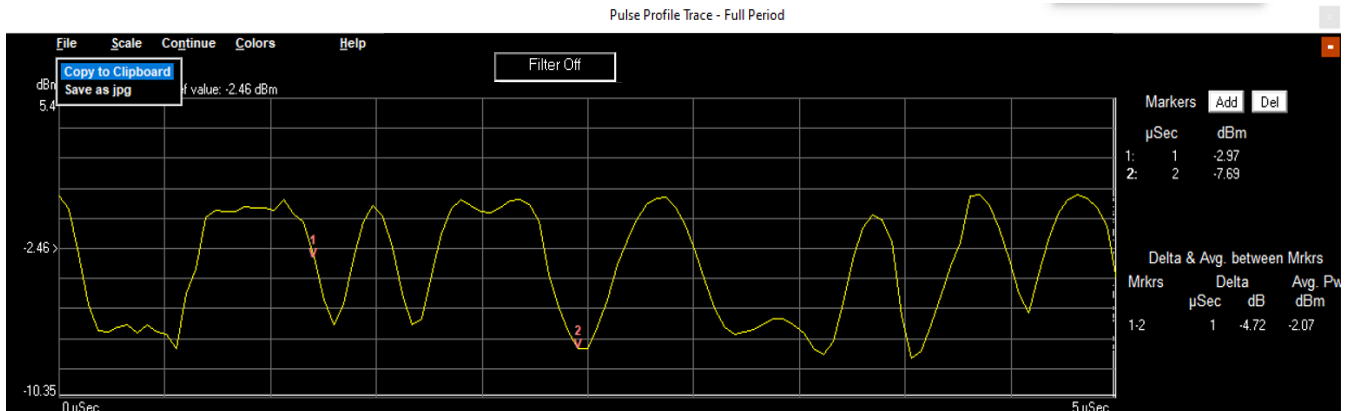

**ASK @ 5 Mps**

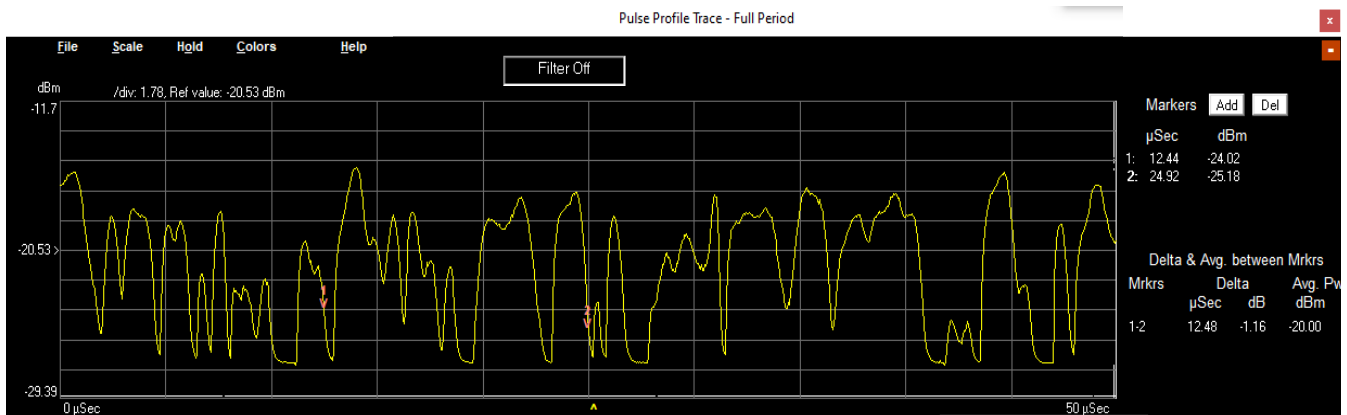

**QAM256 in DECT setup, Gaussian filter @ 1.152 Mps**

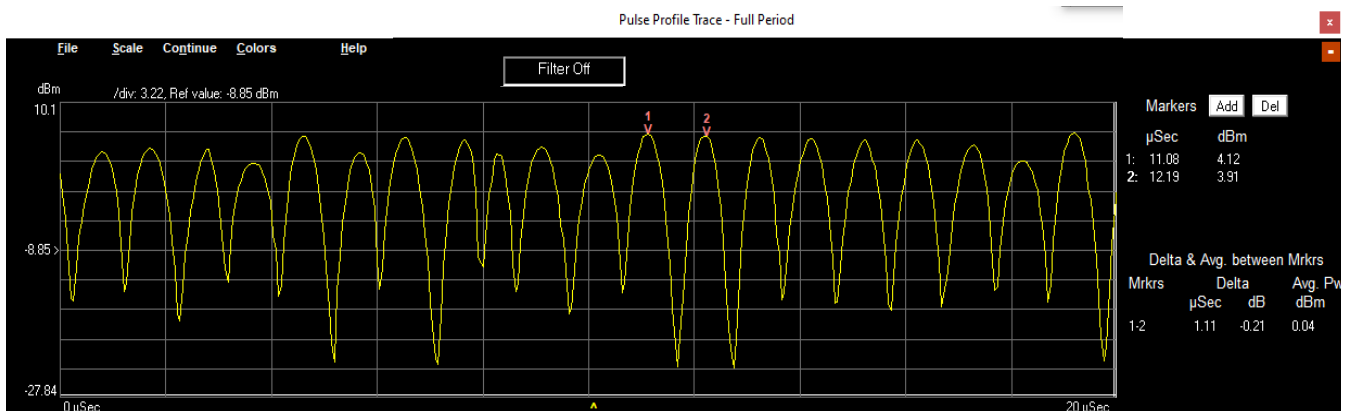

**QPSK, QAM16 & QAM64 in LTE uplink setup (1.4 MHz channels, 3.7 MHz offsets) 8 MHz clock**





### BLOCK DIAGRAM

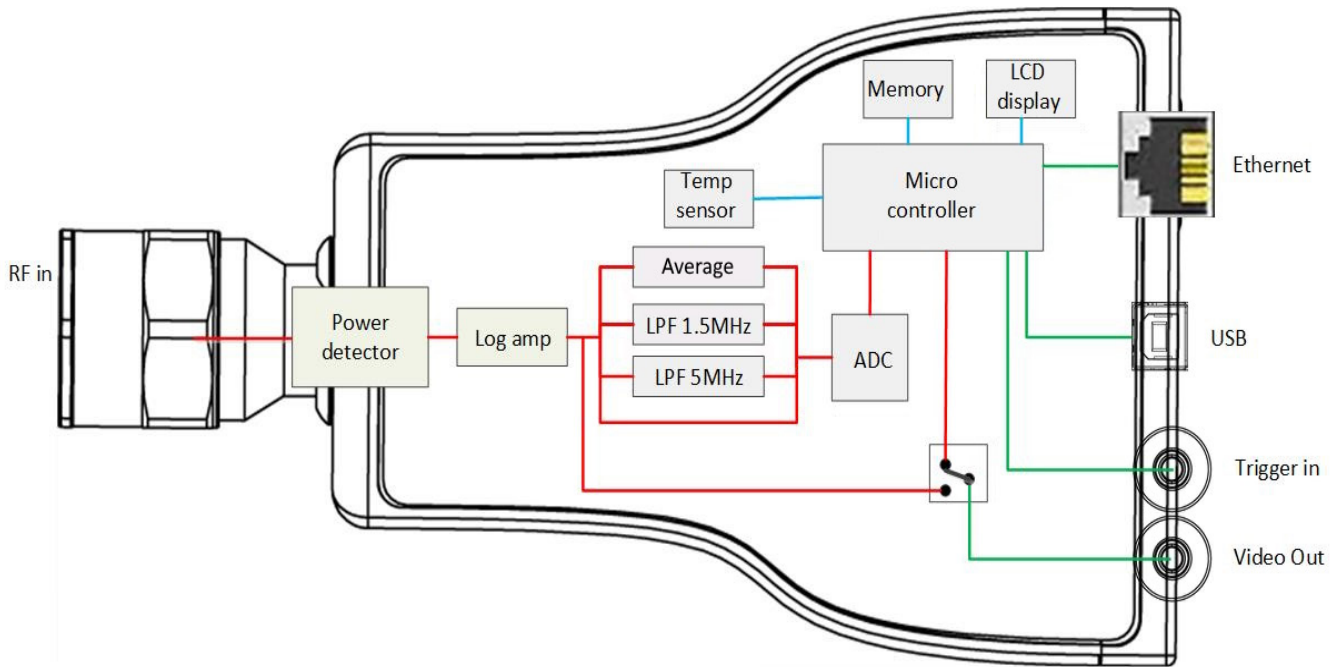

### ABSOLUTE MAXIMUM RATINGS <sup>13, 14</sup>

Operating Temperature	0°C to +50°C
Storage Temperature	-30°C to +70°C
DC Voltage at RF Ports	5 V
Trigger In	-0.3 to 5.5 V
CW Power	+26 dBm

13. Permanent damage may occur if any of these limits are exceeded.  
 14. Operating in the range between operating power limits and absolute maximum ratings for extended periods of time may result in reduced life and reliability.

### CONNECTIONS

Port Name	Connector Type
RF Input	N-type Male
Trigger In	SMB Male
Trigger Out	SMB Male
USB	USB type-C (with screw lock)
Ethernet	RJ45 Socket



### CASE STYLE DRAWING (JL3470)

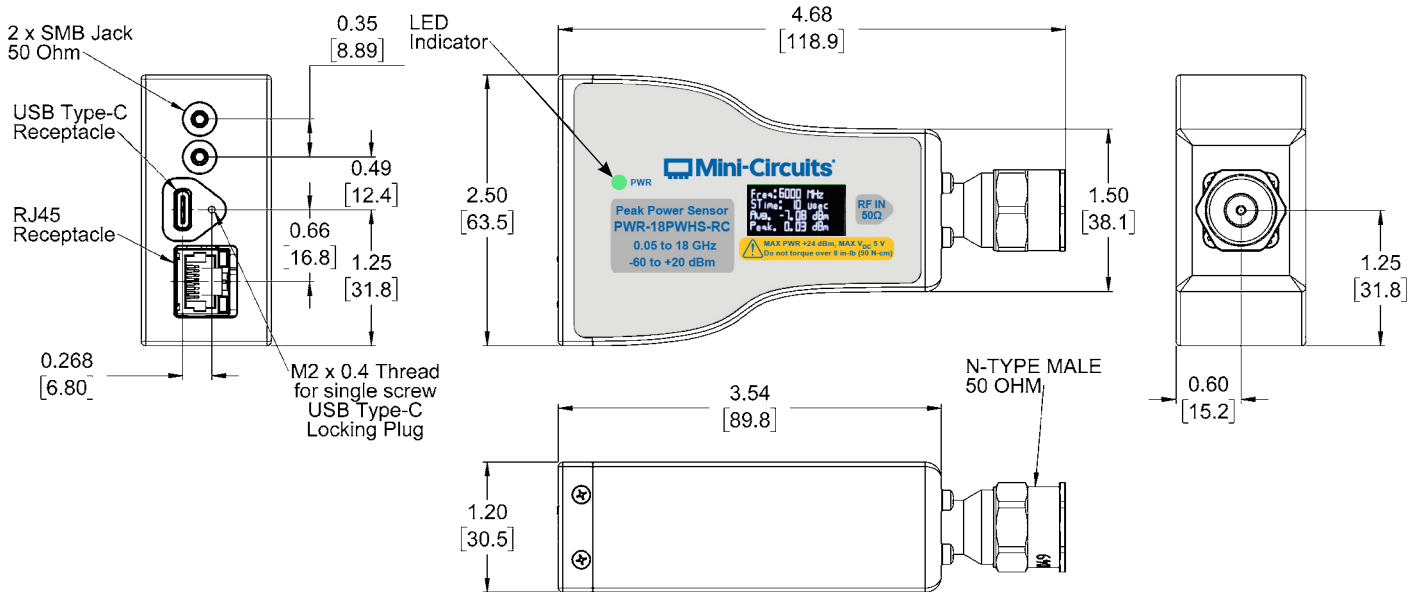

#### NOTES:

1. Case material: Aluminum alloy.
2. Case Finish: Nickel Plate.
3. Dimensions: Inches [mm].  
Tolerances 2 Pl. ±.03 inch; 3 Pl. ±.015 inch.
4. Weight: 260 grams
5. Marking may contain other features or characters for internal lot control.
6. Maximum torque 8 in-lb (90 N-cm).
7. Unit provided with removable protective sleeve (see image below).

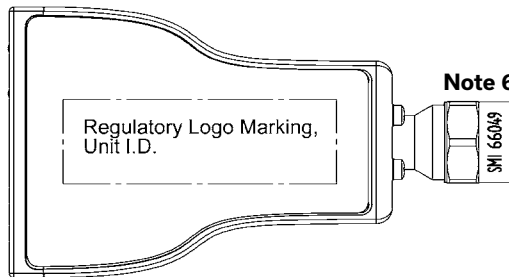

#### Note 7





## CONNECTION DIAGRAMS USB CONTROL

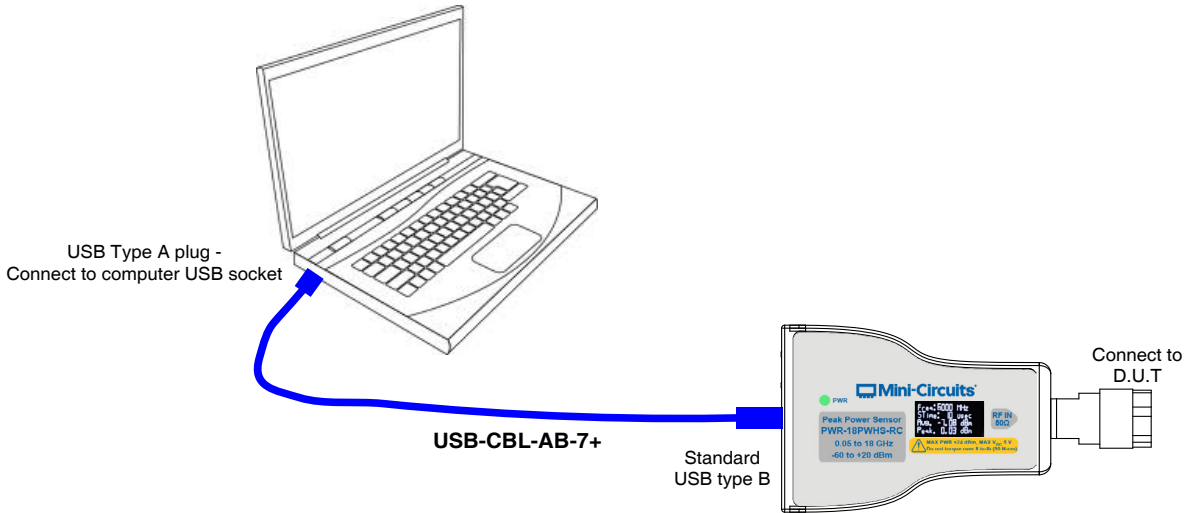

## ETHERNET CONTROL (USING POWER ADAPTER)

Connect USB-AC/DC-5 to mains power

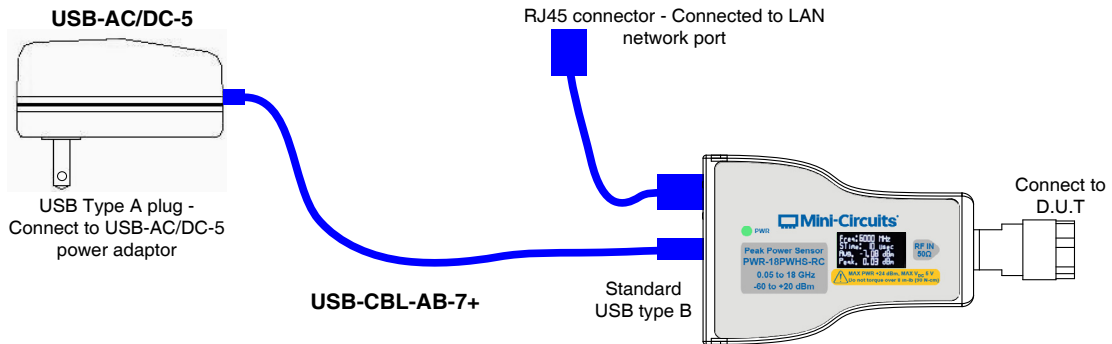

## ETHERNET CONTROL (USING POE SYSTEM)

Note:  
Commercially available PoE splitter not supplied by Mini-Circuits.

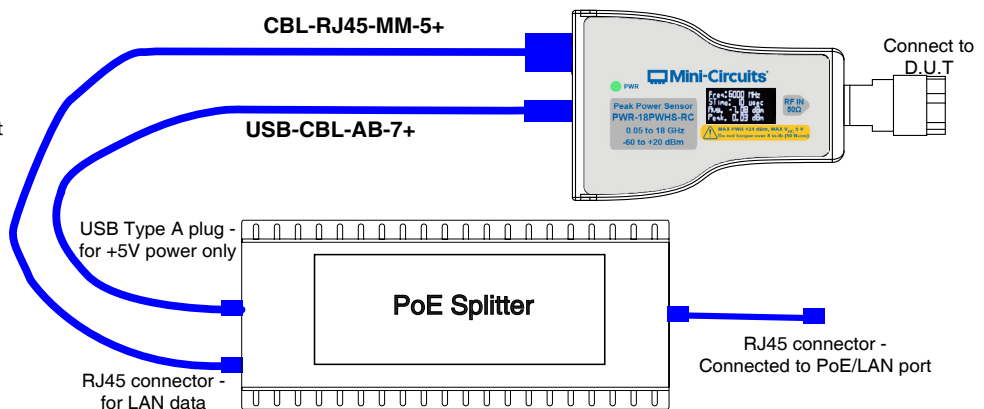



## USB & ETHERNET

# Smart Power Sensor

## PWR-18PWHS-RC





50Ω 0.05 to 18 GHz -60 to +20 dBm Peak & Average N-Type Male

DETAILED MODEL INFORMATION IS AVAILABLE ON OUR WEBSITE [CLICK HERE](#)





Performance Data & Graphs	Data Graphs
Case Style	JL3470
Environmental Rating	ENV50
Software, User Guide & Programming Manual	<a href="https://www.minicircuits.com/softwaredownload/pm.html">https://www.minicircuits.com/softwaredownload/pm.html</a>
Regulatory Compliance	<p>Refer to user guide for compliance information</p>  <p><a href="https://www.minicircuits.com/app/AN48-003.pdf">https://www.minicircuits.com/app/AN48-003.pdf</a></p>
Support	<a href="mailto:testsolutions@minicircuits.com">testsolutions@minicircuits.com</a>

### INCLUDED ACCESSORIES <sup>15</sup>

	Part No.	Description	Qty.
	USB-CBL-AC-7SC+	7.0 ft (2.0 m) USB Cable: USB type A (Male) to USB type C (Male)	1
	CBL-5FT-BMSMB+	5.0 ft (1.5 m) Trigger cable: BNC (Male) to SMB (Female)	1

15. Additional quantities are available for purchase as optional accessories.

### OPTIONAL ACCESSORIES

	Part No.	Description
	CBL-RJ45-MM-5+	5.0 ft (1.5 m) Ethernet cable: RJ45 (Male) to RJ45 (Male) Cat 5E cable
	NF-SF50+	N-Type Female to SMA Female Adapter
	NF-SM50+	N-Type Female to SMA Male Adapter
	NF-BM50+	N-Type Female to BNC Male Adapter
	USB-AC/DC-5+	AC/DC +5V power adaptor with USB connector <sup>16,17</sup>

16. Includes power plugs for US, UK, EU, IL, AU & China. Plugs for other countries are also available. If you need a power cord for a country not listed please contact [testsolutions@minicircuits.com](mailto:testsolutions@minicircuits.com)

17. Power adaptor, powered hub or USB 3.0/3.1 port may be used to provide power when in Ethernet control, not needed in USB control.

### CALIBRATION

Part No.	Description
CALSEN-18PWHS-RC	Calibration Service for PWR-18PWHS-RC <a href="#">CLICK HERE</a>

#### NOTES:

- Performance and quality attributes and conditions not expressly stated in this specification document are intended to be excluded and do not form a part of this specification document.
- Electrical specifications and performance data contained in this specification document are based on Mini-Circuit's applicable established test performance criteria and measurement instructions.
- The parts covered by this specification document are subject to Mini-Circuits standard limited warranty and terms and conditions (collectively, "Standard Terms"); Purchasers of this part are entitled to the rights and benefits contained therein. For a full statement of the Standard Terms and the exclusive rights and remedies thereunder, please visit Mini-Circuits' website at <https://www.minicircuits.com/terms/viewterm.html>



## Typical Performance Data

Test Conditions: @ Temperature = 25°C (unless otherwise stated).

Freq. (GHz)	Uncertainty of power measurement (dBm)								
	-60 dBm	-50 dBm	-40 dBm	-30 dBm	-20 dBm	-10 dBm	0 dBm	+10 dBm	+20 dBm
0.05	-0.07	-0.02	-0.01	-0.03	-0.02	0.00	-0.03	0.02	0.01
0.10	0.02	0.01	0.02	0.00	0.01	0.05	-0.01	0.01	0.02
0.25	-0.03	0.01	0.02	0.00	0.01	0.06	0.01	0.02	0.01
0.50	-0.11	0.01	0.02	0.00	0.01	0.07	0.04	0.04	-0.01
1.00	0.06	0.01	0.03	0.00	-0.01	0.07	-0.02	-0.01	0.00
1.50	-0.11	0.01	0.06	0.03	0.00	0.05	-0.06	-0.03	-0.01
2.00	0.07	0.04	0.05	0.03	0.03	0.07	0.03	0.08	0.07
2.50	0.03	0.10	0.12	0.06	0.09	0.14	0.01	0.09	0.11
3.00	-0.02	0.11	0.14	0.06	0.14	0.14	0.04	0.06	0.06
3.50	0.16	0.09	0.15	0.06	0.16	0.13	0.01	-0.04	0.03
4.00	0.12	0.11	0.12	0.03	0.20	0.15	0.04	0.08	0.14
4.50	0.00	0.12	0.20	0.07	0.16	0.12	-0.04	0.03	0.14
5.00	0.14	0.12	0.17	0.17	0.17	0.12	0.00	0.02	0.06
5.50	0.16	0.09	0.08	0.11	0.08	0.12	0.01	0.07	0.12
6.00	0.12	0.19	0.23	0.23	0.18	0.20	0.12	0.08	0.13
6.50	0.26	0.13	0.17	0.17	0.11	0.13	0.07	0.07	0.19
7.00	0.28	0.13	0.10	0.14	0.12	0.16	0.15	0.11	0.26
7.50	0.28	0.23	0.07	0.13	0.14	0.17	0.12	0.11	0.22
8.00	0.09	0.17	0.08	0.12	0.10	0.13	0.10	0.10	0.19
8.50	-0.07	0.17	0.06	0.08	0.04	0.10	0.09	0.06	0.19
9.00	0.16	0.14	0.06	0.10	0.06	0.11	0.06	0.01	0.09
9.50	0.02	0.12	0.12	0.12	0.06	0.10	0.14	0.00	0.08
10.00	0.16	0.14	0.05	0.11	0.07	0.10	0.06	-0.04	0.13
10.50	0.11	0.16	0.13	0.14	0.13	0.16	0.09	0.06	0.17
11.00	0.13	0.19	0.13	0.14	0.14	0.16	0.08	0.09	0.12
11.50	0.16	0.14	0.14	0.14	0.08	0.13	0.08	0.11	0.11
12.00	0.06	0.15	0.13	0.14	0.12	0.13	0.08	0.12	0.11
12.50	0.17	0.18	0.17	0.14	0.12	0.13	0.05	0.21	0.21
13.00	-0.02	0.14	0.10	0.10	0.01	0.07	-0.01	0.06	0.09
13.50	0.30	0.17	0.19	0.16	0.06	0.13	0.05	0.12	0.13
14.00	-0.12	0.19	0.26	0.25	0.21	0.22	0.17	0.17	0.22
14.50	-0.01	0.18	0.25	0.25	0.15	0.16	0.09	0.16	0.10
15.00	0.13	0.22	0.26	0.26	0.15	0.16	0.07	0.11	0.15
15.50	0.04	0.25	0.23	0.22	0.18	0.19	0.12	0.15	0.18
16.00	0.04	0.34	0.30	0.32	0.25	0.28	0.25	0.19	0.23
16.50	0.08	0.29	0.28	0.29	0.29	0.28	0.30	0.25	0.25
17.00	0.13	0.26	0.22	0.07	0.26	0.21	0.26	0.23	0.23
17.25	0.18	0.25	0.19	0.07	0.25	0.20	0.21	0.21	0.27
17.50	0.22	0.23	0.16	0.07	0.23	0.18	0.16	0.19	0.30
17.75	0.31	0.21	0.15	0.06	0.21	0.17	0.13	0.16	0.23
18.00	0.39	0.19	0.14	0.04	0.18	0.16	0.09	0.12	0.16

## Typical Performance Data

Test Conditions: @ Temperature = 25°C (unless otherwise stated).

Freq. (GHz)	Linearity (%)		
	-55 to -30 dBm	-30 to -5 dBm	-5 to 20 dBm
0.05	0.23%	0.23%	-2.28%
0.10	1.16%	-0.69%	-0.92%
0.25	0.90%	-1.11%	-0.14%
0.50	0.46%	-1.83%	1.16%
1.00	0.23%	0.69%	-0.46%
1.50	0.00%	0.93%	-0.46%
2.00	0.00%	-0.46%	-0.92%
2.50	1.16%	0.93%	-2.05%
3.00	0.69%	-0.69%	0.46%
3.50	-0.92%	0.23%	0.00%
4.00	0.69%	-2.05%	-0.69%
4.50	-0.69%	1.16%	-2.95%
5.00	0.00%	3.28%	-1.14%
5.50	2.33%	1.39%	-2.28%
6.00	-0.92%	1.86%	0.00%
6.50	0.23%	1.39%	-2.28%
7.00	0.93%	0.00%	-3.17%
7.50	3.28%	0.23%	-2.73%
8.00	1.39%	0.00%	-2.28%
8.50	0.93%	-0.69%	-3.17%
9.00	0.00%	0.46%	-1.60%
9.50	-0.92%	1.86%	-1.14%
10.00	0.46%	1.62%	-1.83%
10.50	0.00%	0.46%	-1.37%
11.00	0.00%	-0.92%	0.46%
11.50	-1.60%	1.16%	-1.37%
12.00	0.46%	0.93%	-0.69%
12.50	2.33%	0.46%	-2.28%
13.00	0.00%	0.93%	-1.14%
13.50	-0.46%	2.09%	-2.73%
14.00	-2.05%	-0.92%	0.46%
14.50	1.62%	1.16%	0.93%
15.00	0.46%	2.09%	0.00%
15.50	1.86%	1.86%	-1.60%
16.00	0.00%	1.62%	-0.23%
16.50	0.69%	-0.46%	0.93%
17.00	6.66%	-3.39%	-0.46%
17.25	3.79%	-2.95%	-1.59%
17.50	0.93%	-2.50%	-2.73%
17.75	3.06%	-3.39%	-1.36%
18.00	5.20%	-4.28%	0.00%

Freq. (GHz)	R. Loss (dB)
0.05	-59.65
0.10	-66.76
0.25	-49.64
0.50	-38.96
1.00	-30.39
1.50	-27.76
2.00	-26.53
2.50	-26.19
3.00	-26.68
3.50	-26.67
4.00	-24.99
4.50	-22.37
5.00	-20.17
5.50	-18.87
6.00	-19.10
6.50	-21.17
7.00	-25.61
7.50	-36.76
8.00	-36.57
8.50	-29.66
9.00	-26.56
9.50	-24.35
10.00	-23.01
10.50	-23.51
11.00	-27.60
11.50	-30.49
12.00	-30.23
12.50	-30.93
13.00	-29.09
13.50	-30.94
14.00	-24.69
14.50	-29.61
15.00	-25.78
15.50	-25.50
16.00	-34.19
16.50	-22.84
17.00	-26.99
17.25	-26.95
17.50	-27.62
17.75	-27.61
18.00	-25.25

## Typical Performance Graphs

Test Conditions: @ Temperature = 25°C (unless otherwise stated).

### Uncertainty in Power Measurement @ Low Power Input

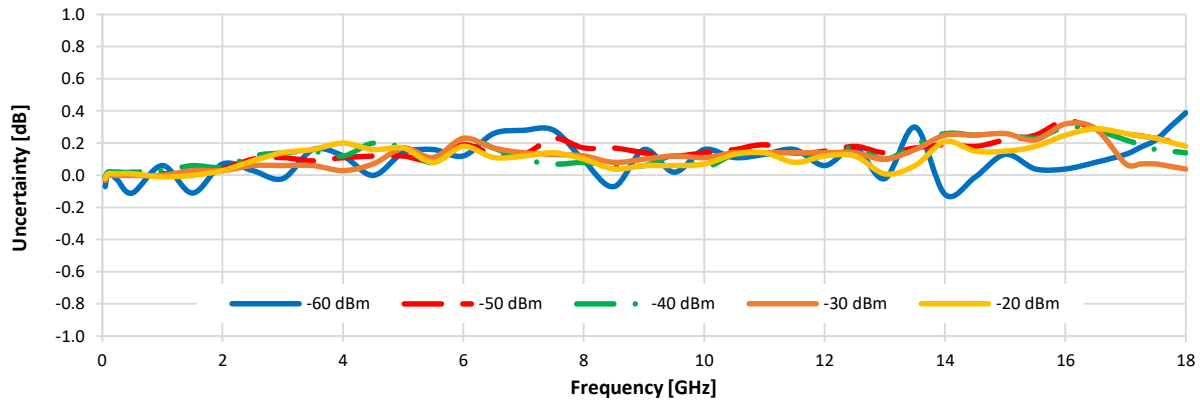

### Uncertainty in Power Measurement @ High Power Input

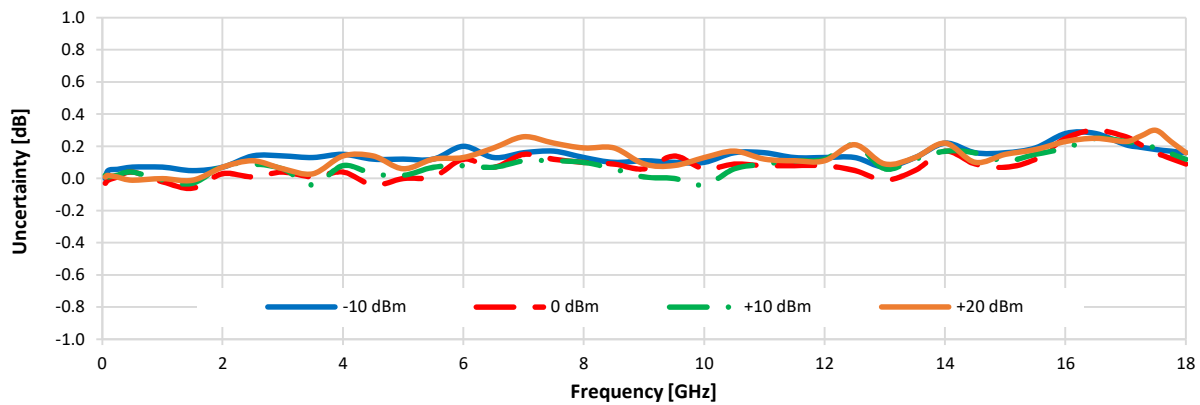

## Typical Performance Graphs

Test Conditions: @ Temperature = 25°C (unless otherwise stated).

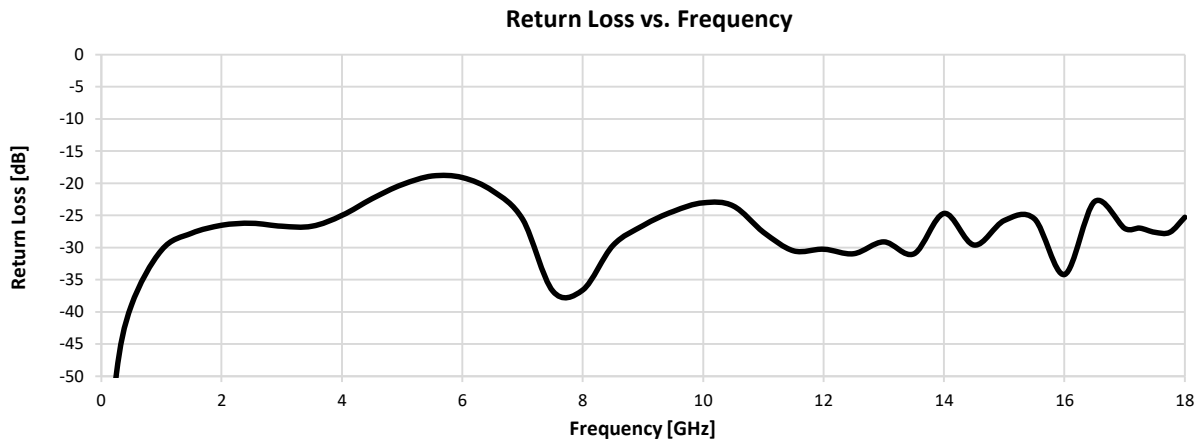
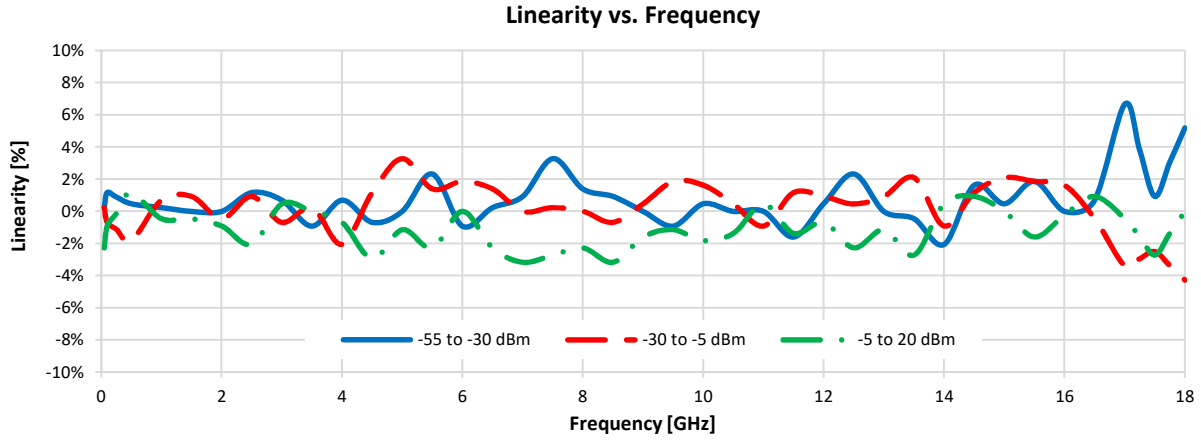



# Case Style

# JL

## Outline Dimensions

## JL3470

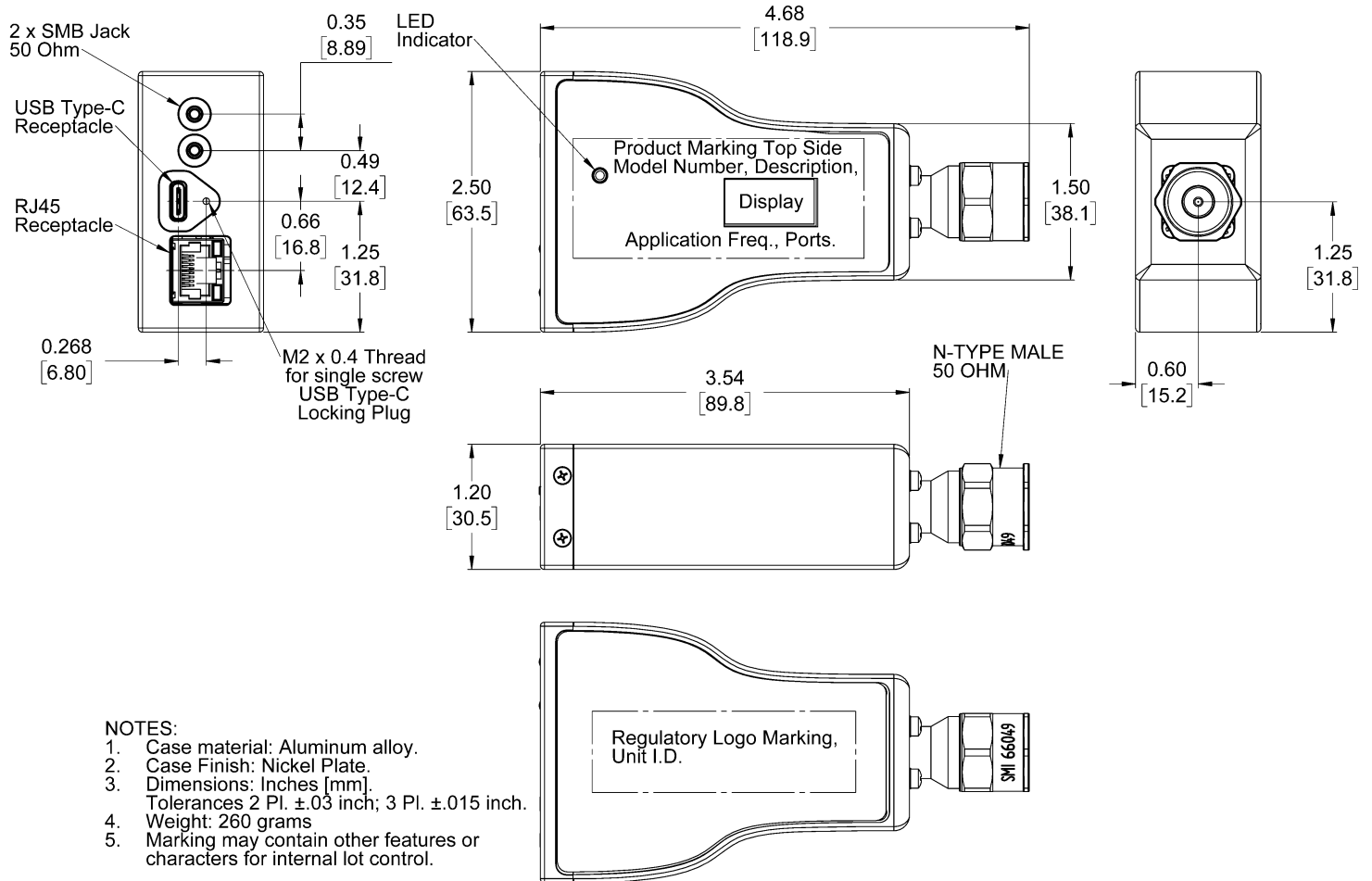

### NOTES:

1. Case material: Aluminum alloy.
2. Case Finish: Nickel Plate.
3. Dimensions: Inches [mm].  
Tolerances 2 Pl.  $\pm 0.03$  inch; 3 Pl.  $\pm 0.015$  inch.
4. Weight: 260 grams
5. Marking may contain other features or characters for internal lot control.



[www.minicircuits.com](http://www.minicircuits.com) P.O. Box 350166, Brooklyn, NY 11235-0003 (718) 934-4500 sales@minicircuits.com



Environmental Specifications **ENV50**

All Mini-Circuits products are manufactured under exacting quality assurance and control standards, and are capable of meeting published specifications after being subjected to any or all of the following physical and environmental test.

Specification	Test/Inspection Condition	Reference/Spec
Operating Temperature	-0° to 50° C Ambient Environment	Individual Model Data Sheet
Storage Temperature	-30° to 70° C Ambient Environment	Individual Model Data Sheet
Operating and Storage Humidity	5% to 85% RH (non-condensing)	Ambient
Bench Handling Test	Bench Top Tip 45° & Drop	MIL-PRF-28800F
Transit Drop Test	Free Fall Drop, 20 cm (7.9 inches)	MIL-PRF-28800F Class 3