



## MMIC SURFACE MOUNT

# Variable Gain Amplifier

# PVGA-273+

50Ω 0.3 to 26.5 GHz High Dynamic Range

### THE BIG DEAL

- Wide Bandwidth, 0.3 to 26.5 GHz
- Output P1dB, Typ. +15 dBm
- High OIP3, Typ. +29 dBm
- Adjustable Gain Range, Typ. 30 dB
- Supply Voltage, +5 V or +8 V
- 5x5 mm 32-Lead QFN-Style Package

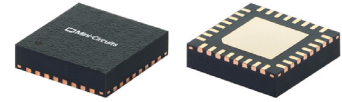

Generic photo used for illustration purposes only

### FUNCTIONAL DIAGRAM

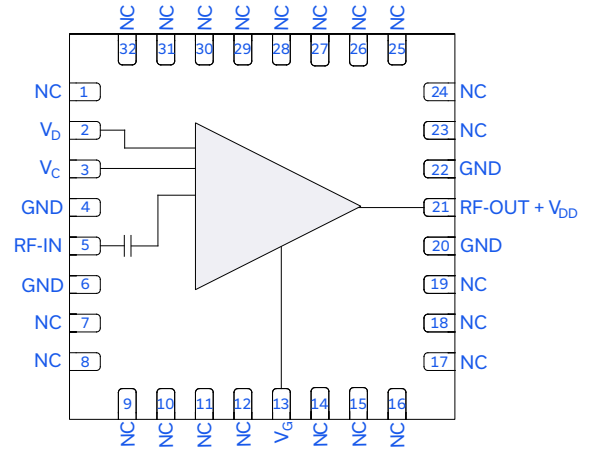

### APPLICATIONS

- Test and Measurement Equipment
- Radar, EW, and ECM Defense Systems
- 5G MIMO and Back Haul Radio Systems
- Signal Distribution Networks

### PRODUCT OVERVIEW

Mini-Circuits' PVGA-273+ is a low noise variable gain MMIC amplifier fabricated in GaAs pHEMT technology. Operating from 0.3 to 26.5 GHz, this amplifier features a high dynamic range with a 2.6 dB noise figure, 13.9 dB gain, +15 dBm P1dB, and +29 dBm OIP3. This design has the flexibility to operate from a +8 V drain voltage applied directly to the device or a +5 V drain voltage applied via a bias tee through the output port. An additional, optional supply voltage may be applied to enable a gain control range of 30 dB. The PVGA-273+ comes in an industry-standard 5x5 mm QFN-style package, with RF ports internally matched to 50Ω, facilitating easy integration into microwave systems.

### KEY FEATURES

Features	Advantages
Wide Bandwidth, 0.3 to 26.5 GHz	Suitable for wide bandwidth defense and test and measurement applications, as well as narrowband performance-driven applications.
High P1dB & OIP3 <ul style="list-style-type: none"> <li>• +15 dBm Typ. P1dB</li> <li>• +29 dBm Typ. OIP3</li> </ul>	Suitable as a driver amplifier in receiver/transmitter chains due to high linearity with low dissipated power.
Adjustable Gain Range <ul style="list-style-type: none"> <li>• 30 dB</li> </ul>	Enables temperature compensation and power control for transmit and receive signal chains.
5x5 mm 32-Lead QFN-Style package	Small footprint saves space in dense layouts while providing low inductance, repeatable transitions, and excellent thermal contact to the PCB. Industry standard packaging allow for ease of assembly in high volume manufacturing processes.

**MMIC SURFACE MOUNT**

# Variable Gain Amplifier

**PVGA-273+**

Mini-Circuits

50Ω 0.3 to 26.5 GHz High Dynamic Range

**ELECTRICAL SPECIFICATIONS<sup>1</sup> AT +25°C, V<sub>c</sub> = OPEN, UNLESS NOTED OTHERWISE**

Parameter	Frequency (GHz)	V <sub>DD</sub> = +5 V (Applied at RF-OUT)			V <sub>D</sub> = +8 V (Applied at Pin 2)			Units
		Min.	Typ.	Max.	Min.	Typ.	Max.	
Frequency Range		0.3		26.5	0.3		26.5	GHz
Gain	0.3		16.8			16.7		dB
	1.0		16.7			16.7		
	6.0		14.6			14.8		
	12.0		13.9			14.1		
	18.0		14.0			14.3		
	26.5		13.1			13.3		
Output Power at 1 dB Compression (P <sub>1dB</sub> )	0.3		+15.6			+14.9		dBm
	1.0		+15.9			+15.4		
	6.0		+16.1			+15.7		
	12.0		+15.0			+14.2		
	18.0		+14.2			+13.7		
	26.5		+12.7			+12.1		
Output Power at Saturation (P <sub>SAT</sub> ) <sup>2</sup>	0.3		+18.9			+17.9		dBm
	1.0		+19.5			+18.2		
	6.0		+19.4			+18.4		
	12.0		+18.4			+17.3		
	18.0		+17.7			+16.7		
	26.5		+19.1			+16.8		
Output Third-Order Intercept (P <sub>OUT</sub> = 0 dBm/Tone)	0.3		+28.4			+26.5		dBm
	1.0		+28.9			+27.2		
	6.0		+28.8			+27.7		
	12.0		+28.8			+26.6		
	18.0		+27.7			+26.2		
	26.5		+23.5			+23.1		
Input Return Loss	0.3		6			7		dB
	1.0		11			11		
	6.0		13			13		
	12.0		10			10		
	18.0		19			20		
	26.5		19			17		
Output Return Loss	0.3		12			11		dB
	1.0		20			20		
	6.0		12			12		
	12.0		11			11		
	18.0		17			17		
	26.5		15			14		
Isolation	0.3 – 26.5		40			39		dB
Noise Figure	0.3		3.0			3.9		dB
	1.0		2.1			2.5		
	6.0		1.9			2.0		
	12.0		2.6			2.3		
	18.0		2.8			2.8		
	26.5		4.2			4.2		
Device Operating Voltage (V <sub>DD</sub> or V <sub>D</sub> )			+5			+8		V
Device Operating Current (I <sub>DD</sub> or I <sub>D</sub> ) <sup>3</sup>			80			80		mA
Gate Voltage (V <sub>G</sub> )		-0.46	-0.38	-0.31	-0.45	-0.37	-0.29	V
Gate Current (I <sub>G</sub> )			0.02			0.02		mA
Control Voltage (V <sub>C</sub> )		-1	Open	+2	-1	Open	+2	V

1. Tested on Mini-Circuits Characterization Test Board TB-PVGA-273C+. See Figure 2. De-embedded to the device reference plane.

2. P<sub>SAT</sub> is defined as when the Output Power changes 0.1 dB per 1 dB change in Input Power.3. Current at P<sub>IN</sub> = -25 dBm. Increases to 89 mA typical at P1dB (V<sub>DD</sub> = +5 V) and 86 mA typical at P1dB (V<sub>D</sub> = +8 V).



MMIC SURFACE MOUNT

# Variable Gain Amplifier

# PVGA-273+

50Ω 0.3 to 26.5 GHz High Dynamic Range

### ELECTRICAL SPECIFICATIONS<sup>4</sup> OVER VARIOUS $V_c$ AT +25°C, $V_{DD} = +5 V$ (APPLIED AT RF-OUT), UNLESS NOTED OTHERWISE

Parameter	Frequency (GHz)	Control Voltage, $V_c$			Units
		-0.7 V Typ.	+1 V Typ.	+2 V Typ.	
DC Current		23	51	82	mA
Gain	0.3	11.2	16.0	16.8	dB
	1.0	10.8	15.9	16.7	
	6.0	6.6	13.5	14.5	
	12.0	5.4	12.8	13.8	
	18.0	5.0	12.9	14.0	
	26.5	2.5	11.9	13.1	
Output Power at 1 dB Compression ( $P_{1dB}$ )	0.3	-2.2	+14.4	+15.5	dBm
	1.0	-2.7	+14.4	+15.8	
	6.0	-4.2	+14.3	+16.0	
	12.0	-3.9	+13.5	+14.9	
	18.0	-3.7	+12.5	+14.1	
	26.5	-3.7	+11.0	+12.6	
Output Power at Saturation ( $P_{SAT}$ ) <sup>5</sup>	0.3	+0.8	+17.3	+18.9	dBm
	1.0	+0.2	+17.7	+19.4	
	6.0	-0.3	+17.6	+19.4	
	12.0	+2.1	+16.9	+18.4	
	18.0	+5.5	+16.1	+17.7	
	26.5	+1.3	+17.7	+19.1	
Output Third-Order Intercept ( $P_{OUT} = -9$ dBm/Tone)	0.3	+5.9	+24.9	+25.9	dBm
	1.0	+5.7	+24.7	+26.4	
	6.0	+4.9	+25.2	+27.4	
	12.0	+5.0	+24.2	+26.2	
	18.0	+4.9	+23.1	+25.4	
	26.5	+5.0	+20.2	+22.0	
Input Return Loss	0.3	4	6	6	dB
	1.0	6	11	11	
	6.0	8	12	13	
	12.0	7	9	10	
	18.0	17	21	19	
	26.5	18	18	19	
Output Return Loss	0.3	13	12	12	dB
	1.0	24	26	25	
	6.0	12	12	12	
	12.0	11	11	11	
	18.0	18	18	18	
	26.5	15	15	15	
Isolation	0.3 – 26.5	33	38	39	dB
Noise Figure	0.3	5.8	4.1	3.9	dB
	1.0	3.3	2.5	2.4	
	6.0	4.1	2.3	2.2	
	12.0	4.4	2.3	2.2	
	18.0	5.2	2.8	2.7	
	26.5	7.1	4.1	4.1	

4. Tested on Mini-Circuits Characterization Test Board TB-PVGA-273C+. See Figure 2. De-embedded to the device reference plane.

5.  $P_{SAT}$  is defined as when the Output Power changes 0.1 dB per 1 dB change in Input Power.



**MMIC SURFACE MOUNT**

# Variable Gain Amplifier

**PVGA-273+**

Mini-Circuits

50Ω 0.3 to 26.5 GHz High Dynamic Range

**ELECTRICAL SPECIFICATIONS<sup>6</sup> OVER VARIOUS  $V_c$  AT +25°C,  $V_D = +8$  V (Applied at Pin 2), UNLESS NOTED OTHERWISE**

Parameter	Frequency (GHz)	Control Voltage, $V_c$			Units
		-0.7 V Typ.	+1 V Typ.	+2 V Typ.	
DC Current		37	58	82	mA
Gain	0.3	15.2	16.2	16.7	dB
	1.0	14.7	16.1	16.7	
	6.0	11.9	14.0	14.8	
	12.0	11.0	13.3	14.1	
	18.0	9.5	13.4	14.2	
	26.5	7.4	12.3	13.2	
Output Power at 1 dB Compression ( $P_{1dB}$ )	0.3	+5.9	+14.2	+14.8	dBm
	1.0	+4.8	+14.0	+15.3	
	6.0	+4.0	+14.2	+15.7	
	12.0	+3.4	+13.4	+14.1	
	18.0	+2.6	+12.3	+13.5	
	26.5	+1.0	+11.2	+11.8	
Output Power at Saturation ( $P_{SAT}$ ) <sup>7</sup>	0.3	+8.9	+17.5	+17.9	dBm
	1.0	+8.4	+17.8	+18.3	
	6.0	+8.4	+17.9	+18.4	
	12.0	+8.0	+16.9	+17.3	
	18.0	+8.6	+16.4	+16.7	
	26.5	+7.1	+16.8	+16.5	
Output Third-Order Intercept ( $P_{OUT} = -9$ dBm/Tone)	0.3	+17.2	+26.0	+26.8	dBm
	1.0	+16.7	+25.5	+27.3	
	6.0	+15.4	+25.5	+28.0	
	12.0	+14.1	+24.5	+26.7	
	18.0	+13.5	+24.4	+27.1	
	26.5	+11.4	+21.3	+23.2	
Input Return Loss	0.3	6	6	7	dB
	1.0	9	11	11	
	6.0	11	12	13	
	12.0	9	9	10	
	18.0	20	21	20	
	26.5	17	17	17	
Output Return Loss	0.3	14	12	11	dB
	1.0	19	26	24	
	6.0	11	12	12	
	12.0	11	11	11	
	18.0	18	18	17	
	26.5	15	14	14	
Isolation	0.3 – 26.5	35	38	39	dB
Noise Figure	0.3	7.5	4.7	3.9	dB
	1.0	4.1	2.8	2.5	
	6.0	2.8	2.1	2.1	
	12.0	3.3	2.3	2.3	
	18.0	3.9	2.8	2.8	
	26.5	5.7	4.2	4.3	

6. Tested on Mini-Circuits Characterization Test Board TB-PVGA-273C+. See Figure 2. De-embedded to the device reference plane.

7.  $P_{SAT}$  is defined as when the Output Power changes 0.1 dB per 1 dB change in Input Power.



### TYPICAL PERFORMANCE GRAPHS WITH $V_{DD} = +5\text{ V}$ AND $V_D = \text{OPEN}$

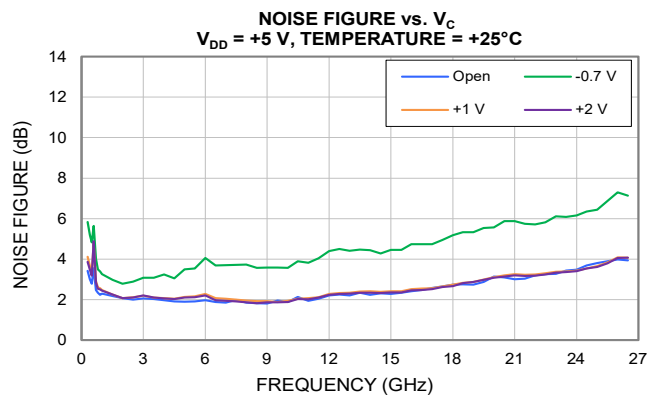
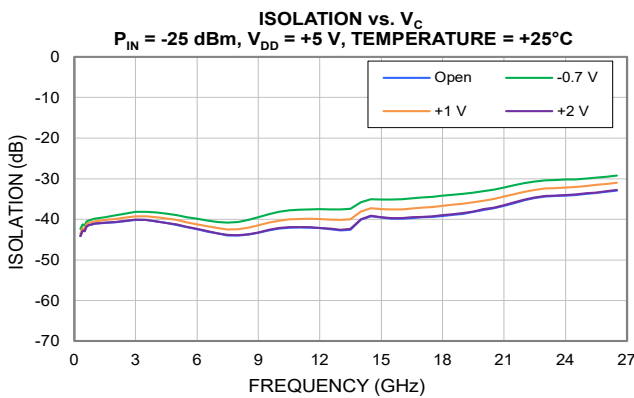
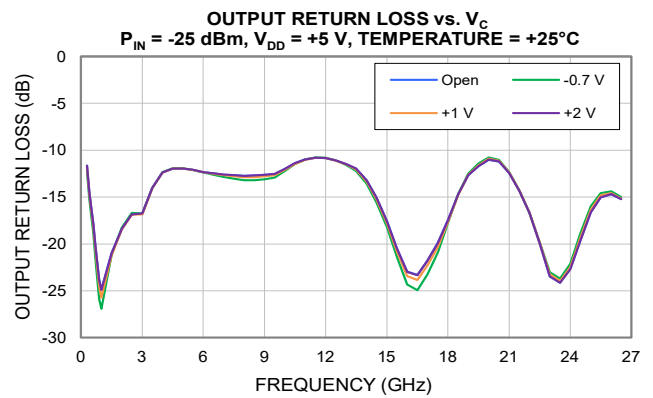
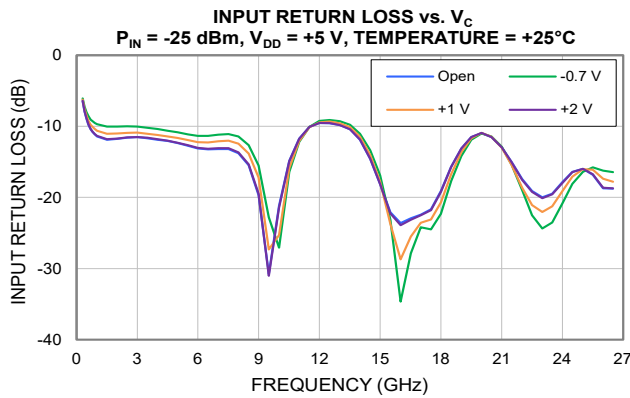
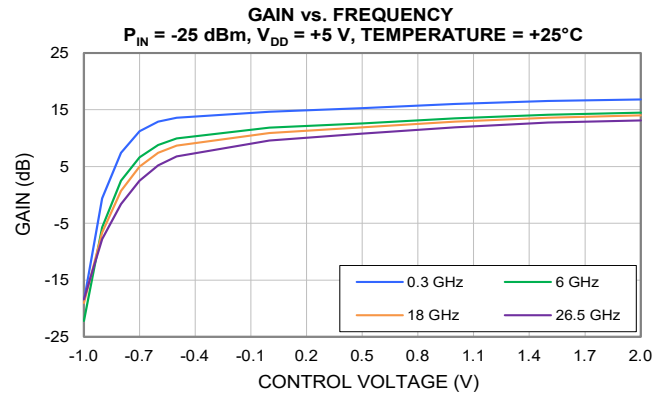
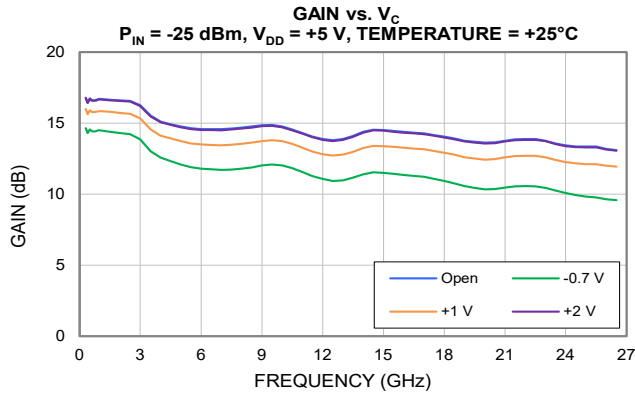



MMIC SURFACE MOUNT

# Variable Gain Amplifier

# PVGA-273+

Mini-Circuits

50Ω 0.3 to 26.5 GHz High Dynamic Range

TYPICAL PERFORMANCE GRAPHS WITH  $V_{DD} = +5\text{ V}$  AND  $V_D = \text{OPEN}$

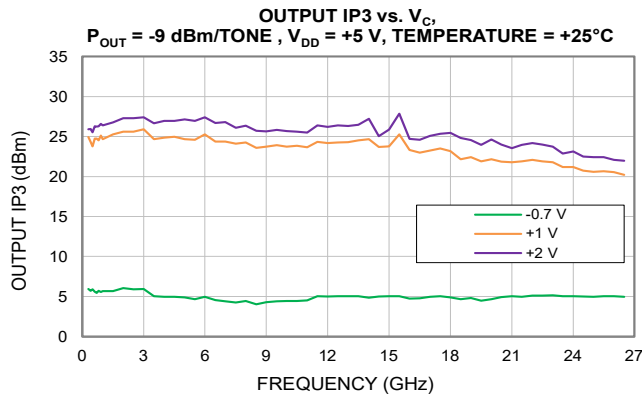
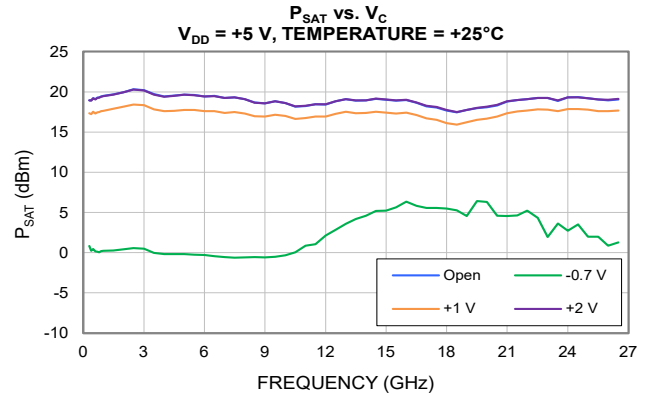
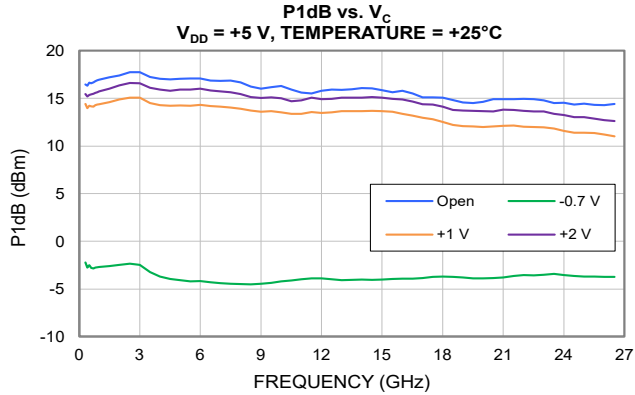



TYPICAL PERFORMANCE GRAPHS WITH  $V_{DD} = +5\text{ V}$  AND  $V_D = \text{OPEN}$ .  
 $V_G$  ADJUSTED AT EACH TEMPERATURE TO SET  $I_{DD} = 80\text{ mA}$

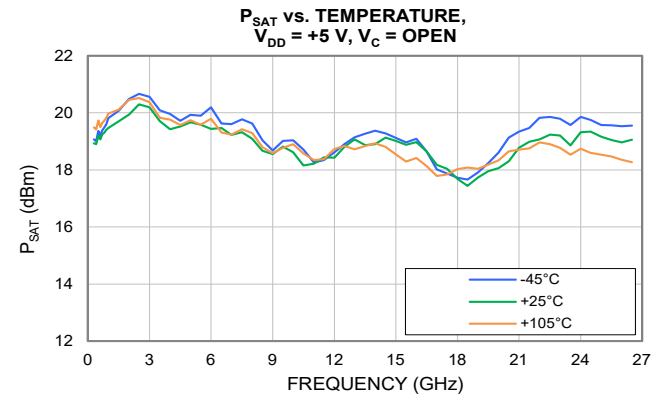
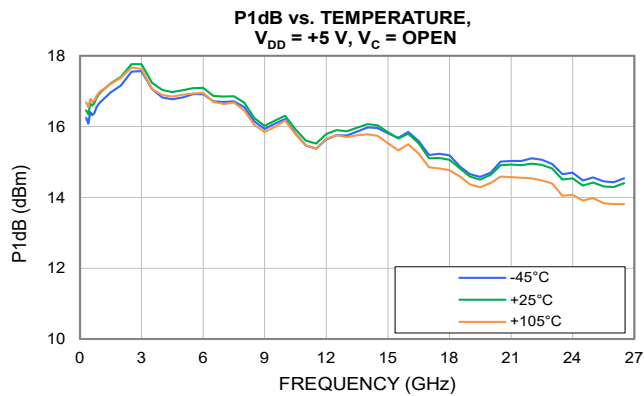
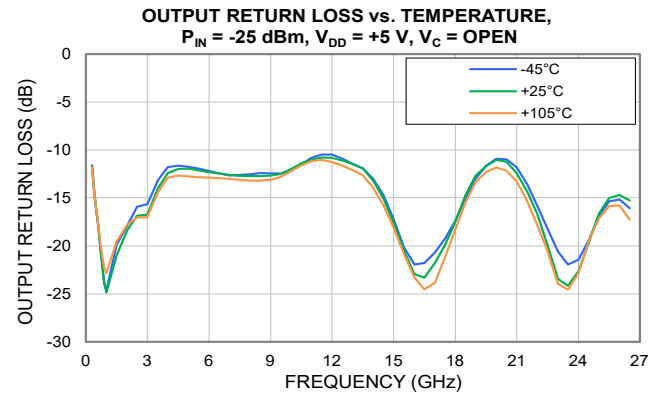
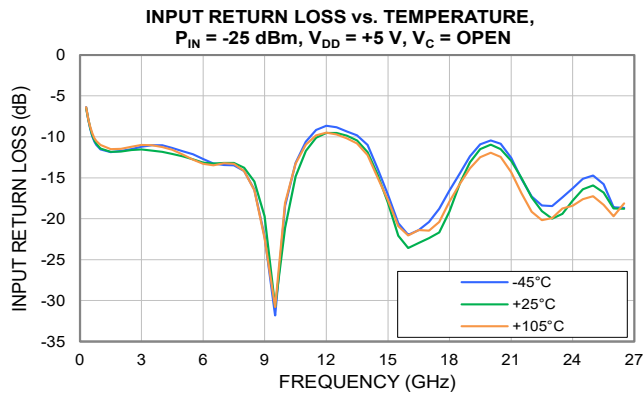
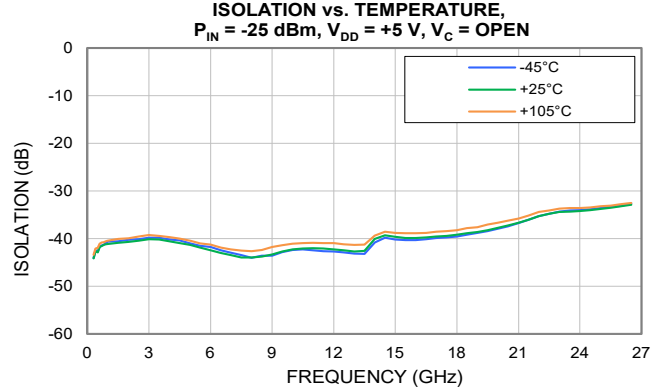
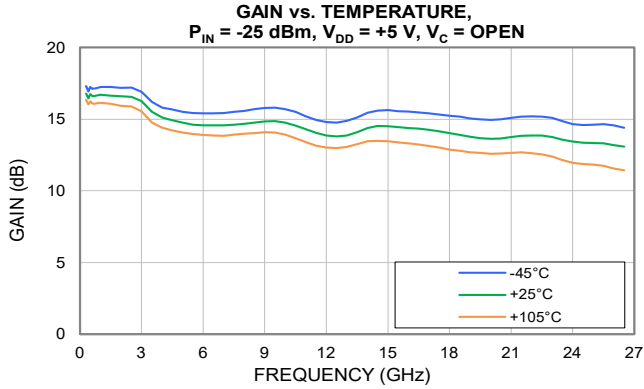



TYPICAL PERFORMANCE GRAPHS WITH  $V_{DD} = +5\text{ V}$  AND  $V_C = \text{OPEN}$ .  
 $V_G$  ADJUSTED AT EACH TEMPERATURE TO SET  $I_{DD} = 80\text{ mA}$ .

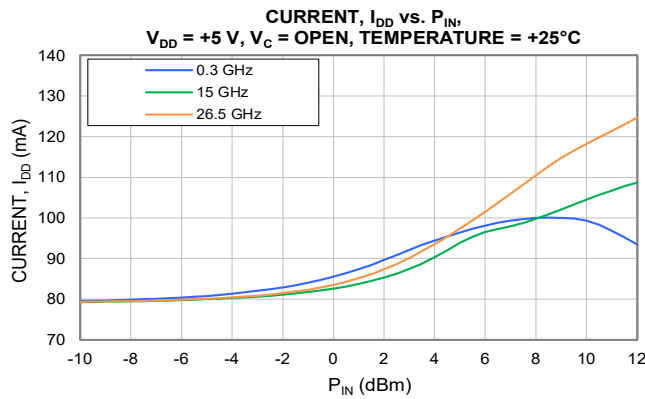
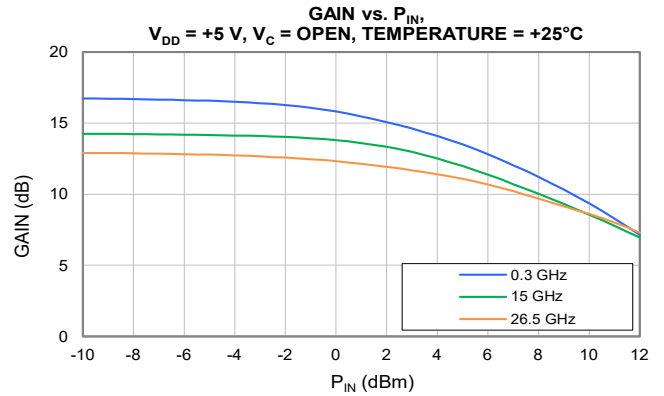
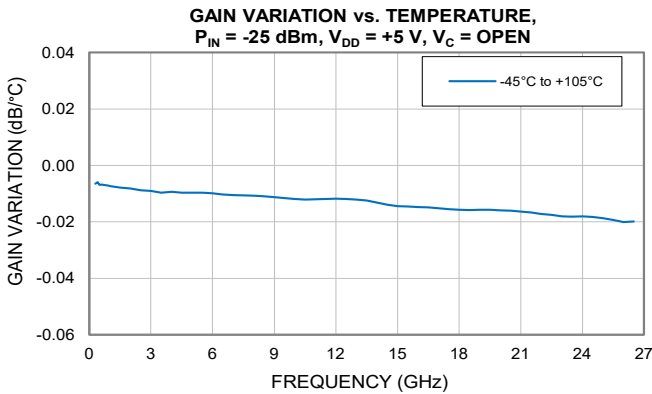
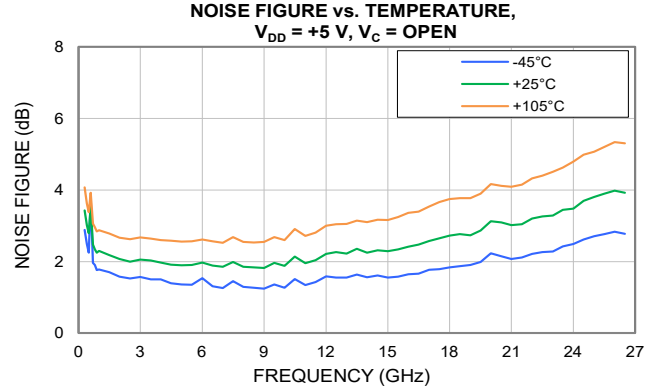
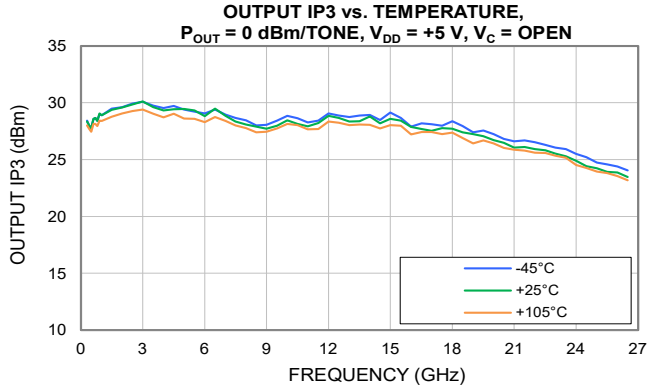





### TYPICAL PERFORMANCE GRAPHS WITH $V_{DD} = \text{OPEN}$ AND $V_D = +8 \text{ V}$

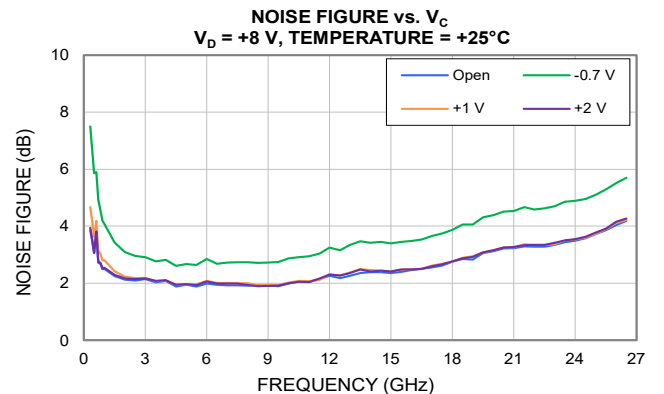
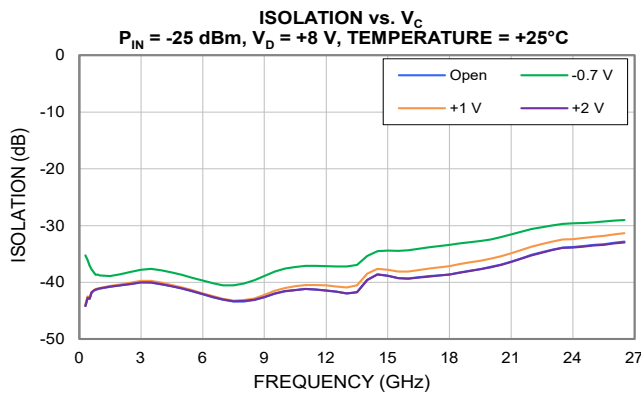
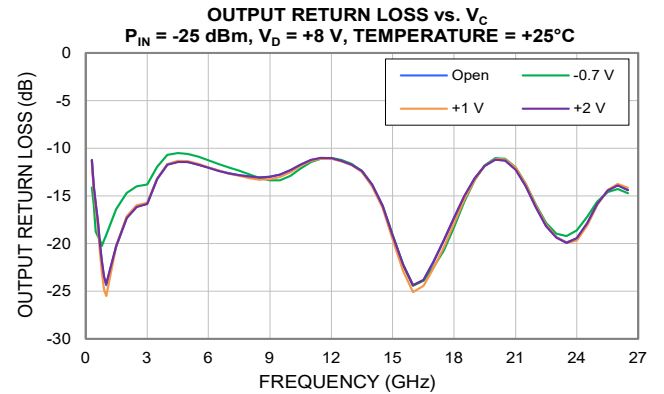
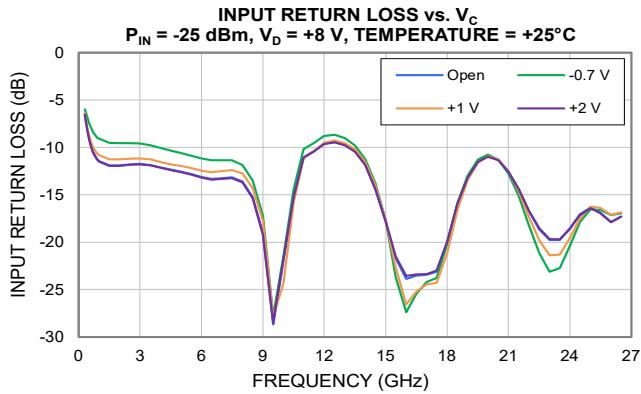
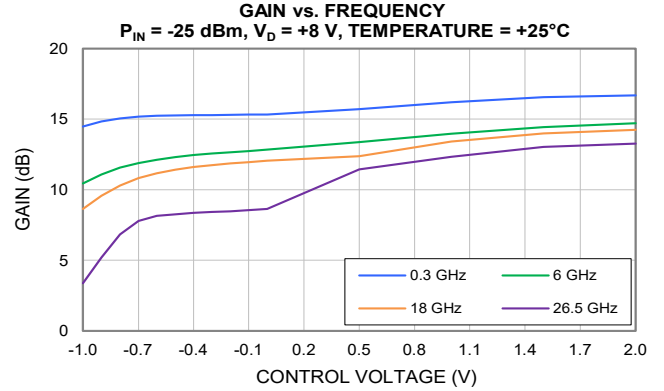
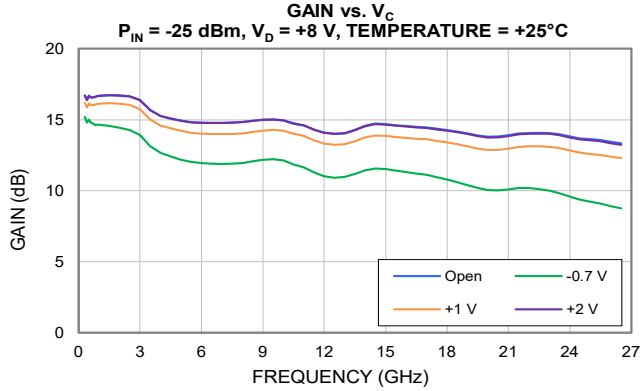



MMIC SURFACE MOUNT

# Variable Gain Amplifier

# PVGA-273+

Mini-Circuits

50Ω 0.3 to 26.5 GHz High Dynamic Range

TYPICAL PERFORMANCE GRAPHS WITH  $V_{DD} = \text{OPEN}$  AND  $V_D = +8\text{ V}$

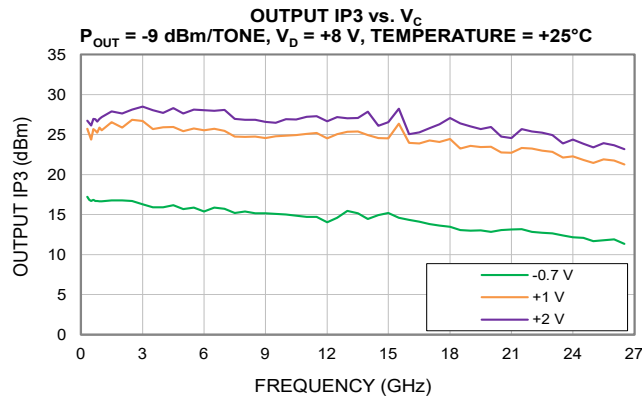
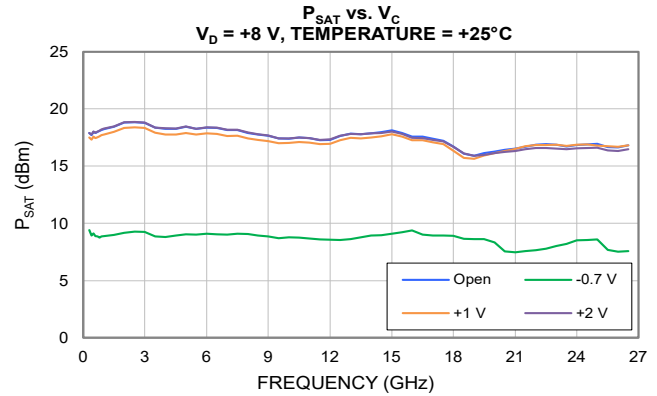
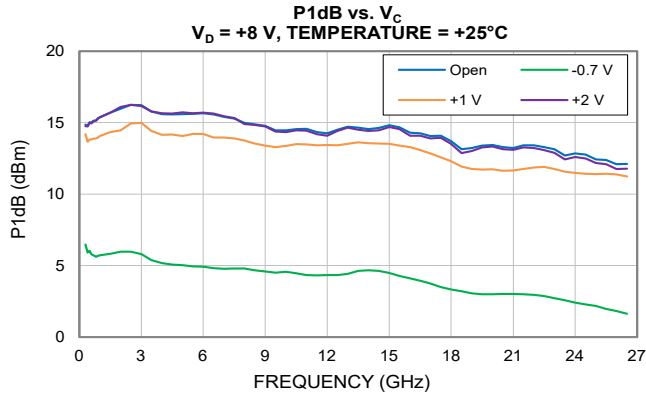



MMIC SURFACE MOUNT

# Variable Gain Amplifier

# PVGA-273+

50Ω 0.3 to 26.5 GHz High Dynamic Range

### ABSOLUTE MAXIMUM RATINGS<sup>8</sup>

Parameter	Ratings
Operating Temperature	-45°C to +105°C
Storage Temperature	-65°C to +150°C
Junction Temperature <sup>9</sup>	+150°C
Total Power Dissipation, $V_{DD} = +5\text{ V}$	2.75 W
Total Power Dissipation, $V_D = +8\text{ V}$	2.75 W
Input Power (CW), $V_{DD} = +5\text{ V}$	+24 dBm
Input Power (CW), $V_D = +8\text{ V}$	+24 dBm
DC Voltage on $V_{DD}$	+11 V
DC Voltage on $V_D$	+11 V
Current $I_{DD}$	250 mA
Current $I_D$	250 mA
DC Voltage on $V_G$	-3.3 V < $V_G$ < 0 V
Current $I_G$	0.18 mA
DC Voltage on $V_C$	+2 V

8. Permanent damage may occur if any of these limits are exceeded. Maximum ratings are not intended for continuous normal operation.

9. Peak temperature on top of Die.

### THERMAL RESISTANCE

Parameter	Ratings
Thermal Resistance ( $\Theta_{JC}$ ) <sup>10</sup>	7.2°C/W

10.  $\Theta_{JC}$  = (Hot Spot Temperature on Die - Temperature at Ground Lead)/Dissipated Power

### ESD RATING

	Class	Voltage Range	Reference Standard
HBM	1A	250 to < 500 V	ANSI/ESDA/JEDEC JS-001-2017
CDM	C3	≥ 1000 V	JESD22-C101F



ESD HANDLING PRECAUTION: This device is designed to be Class 1A for HBM. Static charges may easily produce potentials higher than this with improper handling and can discharge into DUT and damage it. As a preventive measure industry standard ESD handling precautions should be used at all times to protect the device from ESD damage.

### MSL RATING

Moisture Sensitivity: MSL3 in accordance with IPC/JEDEC J-STD-020E/JEDEC J-STD-033C





### FUNCTIONAL DIAGRAM

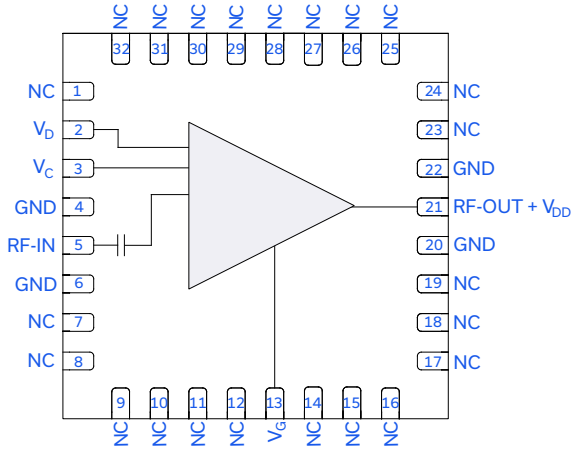

Figure 1. PVGA-273+ Functional Diagram

### PAD DESCRIPTION<sup>11</sup>

Function	Pad Number	Application Description (Refer to Figure 2)
RF-IN	5	RF-IN Pad connects to RF input port.
RF-OUT + V <sub>DD</sub>	21	RF-OUT Pad connects to RF output and V <sub>DD</sub> port.
V <sub>G</sub>	13	DC Input Pad connects to gate voltage input port.
V <sub>D</sub>	2	DC Input Pad connects to drain voltage input port.
V <sub>C</sub>	3	DC Input Pad connects to control voltage input port.
GND	4, 6, 20, 22, & Paddle	Connects to ground.
NC	1, 7-12, 14-19, & 23-32	Not used internally. Connects to ground on characterization test board.

11. V<sub>D</sub> and V<sub>DD</sub> are separate independent voltage pins. PVGA-273+ can be operated by either applying +5V (typ.) to Pad 21 V<sub>DD</sub> or +8V (typ.) to Pad 2 V<sub>D</sub>. Do not apply voltage to both Pad 2 and Pad 21 simultaneously. Applying voltage to both Pad 2 and Pad 21 simultaneously will damage the device.

### CHARACTERIZATION BOARD<sup>12, 13, 14</sup>

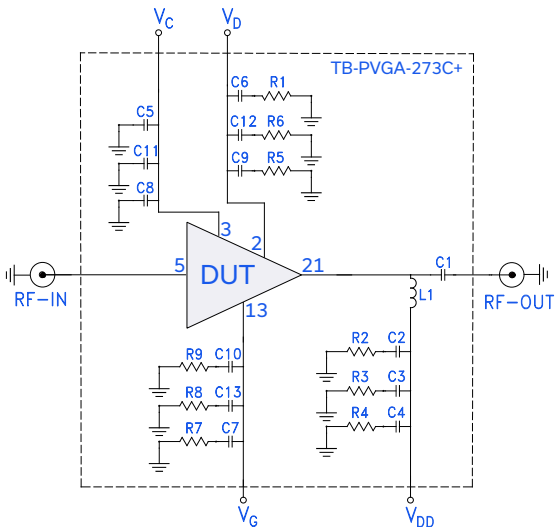

- 12. Characterization data when V<sub>D</sub> = +8 V taken with L1 removed and left Open.
- 13. Components L1, C2, C3, C4, R2, R3, and R4 are not required when biasing through V<sub>D</sub>.
- 14. Components C6, C9, C12, R1, R5, and R6 are not required when biasing through V<sub>DD</sub>.

Figure 2. PVGA-273+ Characterization and Application Circuit.

### Electrical Parameters and Conditions

Gain, Return Loss, Output Power at 1dB Compression (P1dB), Output IP3 (OIP3), and Noise Figure measured using N5247B PNA-X microwave network analyzer.

#### Conditions:

1. Gain and Return Loss: P<sub>IN</sub> = -25 dBm
2. Output IP3 (OIP3): Two tones, spaced 1 MHz apart:
  - a. 0 dBm/Tone at output when V<sub>C</sub> = open.
  - b. -9 dBm/Tone at output when V<sub>C</sub> is varied.

Caution: Permanent damage to the device will occur if the Power ON and Power OFF sequences are not followed.

#### Power ON:

- 1) Set V<sub>G</sub> = -2 V. Apply V<sub>G</sub>.
- 2) Set V<sub>DD</sub> = +5 V or V<sub>D</sub> = +8 V. Apply V<sub>DD</sub> or V<sub>D</sub>.
- 3) Increase V<sub>G</sub> to obtain the desired I<sub>DD</sub> as shown in the Electrical Specification Table.
- 4) Apply V<sub>C</sub> if required, for variable gain control. Not required for typical operation.
- 5) Apply RF signal.

#### Power OFF:

- 1) Turn Off RF signal.
- 2) Turn Off V<sub>C</sub> if applied.
- 3) Adjust V<sub>G</sub> down to -2 V.
- 4) Turn Off V<sub>DD</sub> or V<sub>D</sub>.
- 5) Turn Off V<sub>G</sub>.

Component	Value	Size	Part Number	Manufacturer
L1	0.6 uH	1105	CC36T44K240G5-C	PICONICS
C1	30 pF	0201	P21BN300M5ST	Knowles Dielectric
C2, C8, C9, C10	100 pF	0402	GRM1555C1H101JA01D	Murata
C3	0.01 uF	0402	04023C103KAT2A	AVX Corporation
C4 - C7	4.7 uF	1206	12063C475KAT2A	AVX Corporation
C11 - C13	0.001 uF	0402	GRM1555C1H102JA01D	Murata
R1 - R9	0Ω Jumper	0402	RK73Z1ETTP	KOA Speer



### CASE STYLE DRAWING

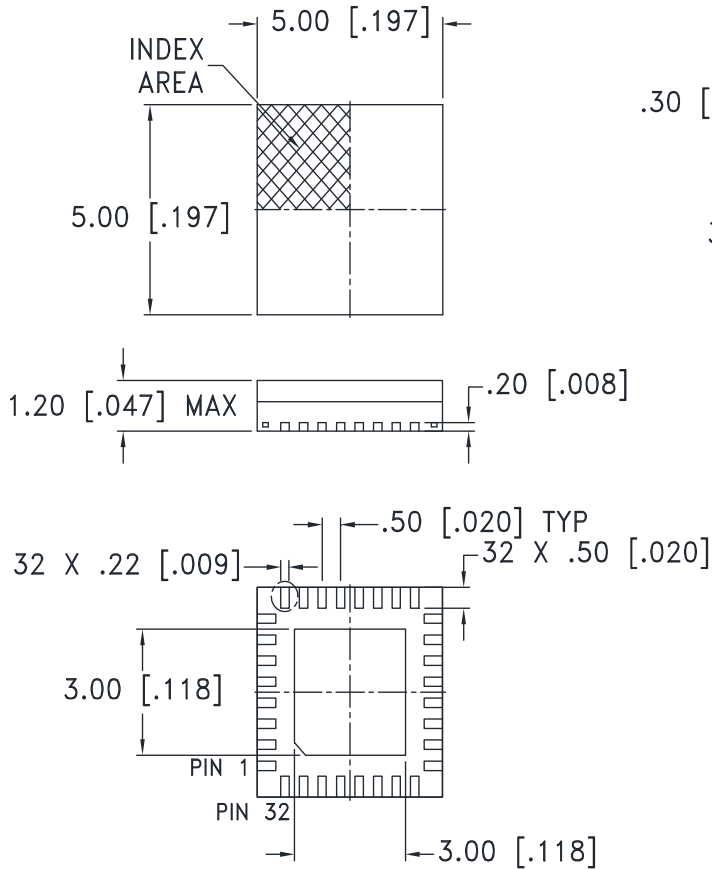

### PCB Land Pattern

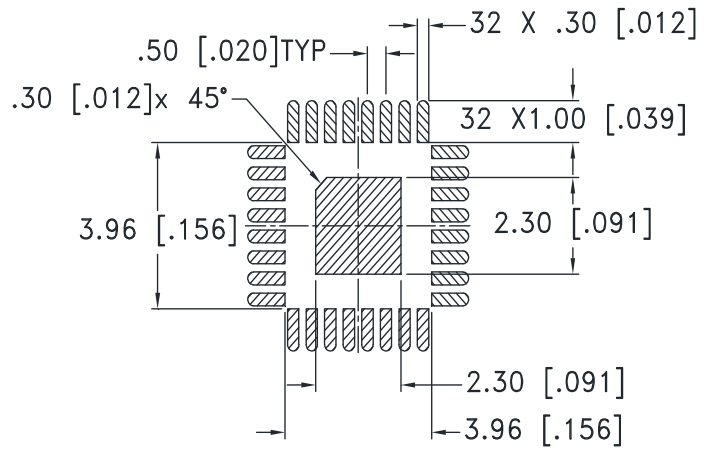

SUGGESTED LAYOUT  
TOLERANCE TO BE WITHIN ±.002

### NOTES:

1. DENOTES METALLIZATION

Weight: 0.1 Grams

Dimensions are in mm [inches]. Tolerances: 2 Pl. ± .25[.01]; 3 Pl. ± .127 [.005]

### PRODUCT MARKING



Marking may contain other features or characters for internal lot control



MMIC SURFACE MOUNT

# Variable Gain Amplifier

## PVGA-273+

50Ω 0.3 to 26.5 GHz High Dynamic Range

ADDITIONAL DETAILED INFORMATION IS AVAILABLE ON OUR DASHBOARD. [CLICK HERE](#)

Performance Data and Graphs	Data
	Graphs
	S-Parameter (S2P Files) Data Set (.zip file)
Case Style	DG1677-4 Plastic package, exposed paddle, Lead Finish: PPF
RoHS Status	Compliant
Tape & Reel	F73
Standard quantities available on reel	7" reels with 20, 50, 100, 200, or 500 devices
Suggested Layout for PCB Design	PL-769
Evaluation Board	TB-PVGA-273C+
	Gerber File
Environmental Ratings	ENV08T10
Product Handling	The use of no-clean solder is recommended. This package cannot be subjected to aqueous wash.

### NOTES

- A. Performance and quality attributes and conditions not expressly stated in this specification document are intended to be excluded and do not form a part of this specification document.
- B. Electrical specifications and performance data contained in this specification document are based on Mini-Circuit's applicable established test performance criteria and measurement instructions.
- C. The parts covered by this specification document are subject to Mini-Circuits standard limited warranty and terms and conditions (collectively, "Standard Terms"); Purchasers of this part are entitled to the rights and benefits contained therein. For a full statement of the standard terms and the exclusive rights and remedies thereunder, please visit Mini-Circuits' website at [www.minicircuits.com/terms/viewterm.html](http://www.minicircuits.com/terms/viewterm.html)



*Typical Performance Data*

**Definitions:**

Input Return Loss = -S11 (dB)

Gain(Power Gain) = S21 (dB)

Reverse Isolation = -S12 (dB)

Output Return Loss = -S22 (dB)

TEST CONDITIONS: V<sub>DD</sub> = +5 V, I<sub>DD</sub> = 80 mA, V<sub>C</sub> = Open @ Temperature = -45°C

FREQ	Gain	Isolation	Input Return Loss	Output Return Loss	Output IP-3 @ P <sub>OUT</sub> = 0 dBm/Tone	1dB Comp. Output	P <sub>SAT</sub> Output	Noise Figure
(GHz)	(dB)	(dB)	(dB)	(dB)	(dBm)	(dBm)	(dBm)	(dB)
0.3	17.3	44.1	6.4	11.6	28.4	16.3	19.1	2.9
0.4	16.9	42.5	7.9	14.3	28.0	16.1	19.0	2.5
0.5	17.3	42.7	9.0	16.2	27.8	16.4	19.4	2.2
0.6	17.1	41.7	9.9	18.1	28.6	16.3	19.2	3.8
0.7	17.1	41.4	10.6	20.2	28.7	16.4	19.4	2.0
0.8	17.2	41.3	11.0	22.0	28.5	16.5	19.5	1.9
0.9	17.2	40.9	11.3	23.8	29.0	16.6	19.6	1.8
1.0	17.2	40.6	11.5	24.7	28.9	16.7	19.8	1.8
1.5	17.3	40.6	11.9	19.9	29.5	17.0	20.1	1.7
2.0	17.2	40.3	11.7	17.9	29.6	17.2	20.5	1.6
2.5	17.2	40.2	11.5	15.9	29.9	17.6	20.7	1.5
3.0	16.9	39.8	11.2	15.7	30.1	17.6	20.6	1.6
3.5	16.2	39.8	11.0	13.2	29.7	17.1	20.1	1.5
4.0	15.8	40.2	11.0	11.8	29.5	16.8	20.0	1.5
4.5	15.7	40.4	11.4	11.6	29.7	16.8	19.7	1.4
5.0	15.5	41.0	11.7	11.7	29.4	16.8	19.9	1.4
5.5	15.4	41.5	12.1	12.0	29.2	16.9	19.9	1.3
6.0	15.4	41.8	12.7	12.2	29.1	16.9	20.2	1.5
6.5	15.4	42.5	13.3	12.5	29.4	16.7	19.6	1.3
7.0	15.4	43.0	13.4	12.7	29.0	16.7	19.6	1.3
7.5	15.5	43.5	13.5	12.6	28.7	16.7	19.8	1.5
8.0	15.6	44.0	14.2	12.5	28.5	16.6	19.6	1.3
8.5	15.7	43.6	16.4	12.4	28.0	16.1	19.0	1.3
9.0	15.8	43.6	22.2	12.4	28.1	15.9	18.7	1.2
9.5	15.8	42.8	31.8	12.4	28.4	16.1	19.0	1.4
10.0	15.7	42.4	18.4	12.1	28.8	16.2	19.0	1.3
10.5	15.5	42.3	13.2	11.5	28.6	15.8	18.7	1.5
11.0	15.2	42.5	10.6	10.8	28.3	15.5	18.3	1.3
11.5	14.9	42.7	9.1	10.5	28.4	15.4	18.4	1.4
12.0	14.8	42.7	8.6	10.5	29.1	15.6	18.6	1.6
12.5	14.8	42.9	8.8	10.9	28.9	15.8	18.9	1.6
13.0	14.9	43.1	9.3	11.4	28.8	15.7	19.1	1.6
13.5	15.1	43.2	9.8	11.9	28.9	15.9	19.3	1.6
14.0	15.4	40.8	11.0	13.0	29.0	16.0	19.4	1.6
14.5	15.6	39.8	13.9	14.7	28.5	16.0	19.3	1.6
15.0	15.6	40.2	17.1	17.2	29.2	15.8	19.1	1.5
15.5	15.6	40.3	20.5	20.1	28.7	15.7	19.0	1.6
16.0	15.5	40.3	22.0	21.9	27.9	15.8	19.1	1.6
16.5	15.5	40.1	21.4	21.8	28.2	15.6	18.7	1.7
17.0	15.4	39.9	20.4	20.7	28.1	15.2	18.0	1.8
17.5	15.3	39.7	18.8	19.2	28.0	15.2	17.9	1.8
18.0	15.2	39.6	16.6	17.4	28.4	15.2	17.7	1.8
18.5	15.2	39.2	14.4	15.1	27.9	14.9	17.7	1.9
19.0	15.1	38.8	12.4	13.0	27.4	14.7	17.9	1.9
19.5	15.0	38.5	10.9	11.7	27.6	14.6	18.2	2.0
20.0	15.0	37.9	10.4	10.9	27.2	14.7	18.6	2.2
20.5	15.0	37.4	10.9	11.0	26.8	15.0	19.1	2.1
21.0	15.1	36.8	12.6	11.8	26.6	15.0	19.3	2.1
21.5	15.2	36.1	15.1	13.6	26.7	15.0	19.5	2.1
22.0	15.2	35.3	17.3	15.8	26.5	15.1	19.8	2.2
22.5	15.2	34.7	18.4	18.2	26.3	15.1	19.9	2.3
23.0	15.1	34.3	18.5	20.6	26.0	14.9	19.8	2.3
23.5	14.9	34.1	17.4	21.9	25.9	14.7	19.6	2.4
24.0	14.7	34.0	16.3	21.4	25.5	14.7	19.9	2.5
24.5	14.6	33.8	15.1	19.4	25.2	14.5	19.8	2.6
25.0	14.6	33.6	14.7	16.9	24.7	14.6	19.6	2.7
25.5	14.7	33.3	15.8	15.4	24.6	14.5	19.6	2.8
26.0	14.6	33.1	18.6	15.2	24.4	14.4	19.5	2.8
26.5	14.4	32.7	18.7	16.1	24.0	14.5	19.6	2.8

*Typical Performance Data*

**NOTE: Use PDF Bookmarks to view DATA at required conditions**

**Definitions:**

Input Return Loss = -S11 (dB)

Gain(Power Gain) = S21 (dB)

Reverse Isolation = -S12 (dB)

Output Return Loss = -S22 (dB)

TEST CONDITIONS: V<sub>DD</sub> = +5 V, I<sub>DD</sub> = 80 mA, V<sub>C</sub> = Open @ Temperature = +25°C

FREQ	Gain	Isolation	Input Return Loss	Output Return Loss	Output IP-3 @ P <sub>OUT</sub> = 0 dBm/Tone	1dB Comp. Output	P <sub>SAT</sub> Output	Noise Figure
(GHz)	(dB)	(dB)	(dB)	(dB)	(dBm)	(dBm)	(dBm)	(dB)
0.3	16.8	44.1	6.4	11.7	28.4	16.5	18.9	3.4
0.4	16.4	42.6	7.9	14.4	28.0	16.3	18.9	3.0
0.5	16.7	42.9	8.9	16.1	27.7	16.6	19.2	2.8
0.6	16.6	41.8	9.8	17.9	28.6	16.6	19.1	3.6
0.7	16.6	41.6	10.4	20.1	28.7	16.7	19.3	2.5
0.8	16.6	41.3	10.8	22.0	28.4	16.8	19.3	2.3
0.9	16.7	41.2	11.1	23.8	29.1	16.9	19.4	2.2
1.0	16.7	41.1	11.4	24.9	28.9	17.0	19.5	2.3
1.5	16.7	40.9	11.9	21.0	29.4	17.2	19.7	2.2
2.0	16.6	40.7	11.8	18.4	29.6	17.4	19.9	2.1
2.5	16.6	40.5	11.6	16.9	29.9	17.8	20.3	2.0
3.0	16.3	40.1	11.5	16.8	30.1	17.8	20.2	2.1
3.5	15.5	40.2	11.7	14.0	29.6	17.2	19.7	2.0
4.0	15.1	40.5	11.9	12.4	29.3	17.0	19.4	2.0
4.5	14.9	40.9	12.1	12.0	29.4	17.0	19.5	1.9
5.0	14.8	41.4	12.4	12.0	29.5	17.0	19.7	1.9
5.5	14.6	41.9	12.7	12.1	29.3	17.1	19.6	1.9
6.0	14.6	42.5	13.1	12.3	28.8	17.1	19.4	2.0
6.5	14.6	43.0	13.3	12.5	29.5	16.9	19.5	1.9
7.0	14.6	43.5	13.2	12.6	28.8	16.8	19.2	1.9
7.5	14.6	44.0	13.2	12.7	28.3	16.9	19.3	2.0
8.0	14.7	44.0	13.8	12.7	28.1	16.7	19.1	1.9
8.5	14.8	43.8	15.5	12.7	27.9	16.2	18.7	1.8
9.0	14.8	43.3	19.7	12.6	27.7	16.0	18.6	1.8
9.5	14.9	42.7	30.8	12.5	28.0	16.2	18.8	2.0
10.0	14.8	42.3	21.2	12.0	28.5	16.3	18.6	1.9
10.5	14.6	42.0	14.8	11.4	28.1	15.9	18.2	2.1
11.0	14.3	42.0	11.7	11.0	27.9	15.6	18.2	2.0
11.5	14.0	42.0	10.1	10.8	28.2	15.5	18.4	2.0
12.0	13.9	42.2	9.5	10.8	28.9	15.8	18.4	2.2
12.5	13.8	42.5	9.5	11.1	28.7	15.9	18.8	2.3
13.0	13.9	42.7	9.8	11.5	28.4	15.9	19.1	2.2
13.5	14.1	42.6	10.4	11.9	28.4	16.0	18.9	2.4
14.0	14.4	40.1	11.9	13.2	28.8	16.1	18.9	2.2
14.5	14.5	39.3	14.6	15.1	28.2	16.0	19.1	2.3
15.0	14.5	39.6	18.1	17.6	28.6	15.8	19.0	2.3
15.5	14.4	39.8	22.1	20.5	28.4	15.7	18.9	2.3
16.0	14.4	39.9	23.6	22.9	27.9	15.8	19.0	2.4
16.5	14.3	39.7	23.0	23.3	27.7	15.5	18.7	2.5
17.0	14.3	39.6	22.4	21.8	27.5	15.1	18.2	2.6
17.5	14.2	39.4	21.7	19.9	27.8	15.1	18.0	2.7
18.0	14.0	39.2	19.1	17.5	27.7	15.1	17.7	2.7
18.5	13.9	38.9	15.7	14.7	27.4	14.8	17.4	2.8
19.0	13.8	38.6	13.1	12.7	27.2	14.6	17.7	2.7
19.5	13.7	38.2	11.5	11.7	27.1	14.5	18.0	2.9
20.0	13.6	37.7	10.9	11.0	26.7	14.6	18.1	3.1
20.5	13.7	37.3	11.5	11.2	26.5	14.9	18.3	3.1
21.0	13.8	36.7	12.9	12.4	26.1	14.9	18.8	3.0
21.5	13.8	36.0	15.0	14.4	26.1	14.9	19.0	3.0
22.0	13.9	35.3	17.4	16.7	25.9	15.0	19.1	3.2
22.5	13.9	34.8	19.1	19.9	25.8	14.9	19.2	3.3
23.0	13.8	34.4	20.0	23.5	25.5	14.8	19.2	3.3
23.5	13.6	34.3	19.4	24.2	25.3	14.5	18.9	3.4
24.0	13.4	34.2	17.8	22.6	24.9	14.5	19.3	3.5
24.5	13.4	34.0	16.4	19.7	24.4	14.3	19.3	3.7
25.0	13.3	33.8	15.9	16.6	24.3	14.4	19.2	3.8
25.5	13.3	33.5	16.8	15.0	23.9	14.3	19.1	3.9
26.0	13.2	33.2	18.7	14.7	23.9	14.3	19.0	4.0
26.5	13.1	32.9	18.8	15.2	23.5	14.4	19.1	3.9



*Typical Performance Data*

**Definitions:**

Input Return Loss = -S11 (dB)

Gain(Power Gain) = S21 (dB)

Reverse Isolation = -S12 (dB)

Output Return Loss = -S22 (dB)

TEST CONDITIONS: V<sub>DD</sub> = +5 V, I<sub>DD</sub> = 80 mA, V<sub>C</sub> = Open @ Temperature = +105°C

FREQ	Gain	Isolation	Input Return Loss	Output Return Loss	Output IP-3 @ P <sub>OUT</sub> = 0 dBm/Tone	1dB Comp. Output	P <sub>SAT</sub> Output	Noise Figure
(GHz)	(dB)	(dB)	(dB)	(dB)	(dBm)	(dBm)	(dBm)	(dB)
0.3	16.3	43.4	6.4	11.8	28.0	16.7	19.5	4.1
0.4	16.0	42.1	7.8	14.5	27.7	16.6	19.4	3.6
0.5	16.2	41.9	8.8	16.1	27.4	16.8	19.7	3.4
0.6	16.1	41.1	9.6	17.8	28.1	16.7	19.5	3.9
0.7	16.1	40.8	10.2	19.6	28.1	16.7	19.6	3.1
0.8	16.1	40.8	10.5	21.0	28.0	16.9	19.7	3.0
0.9	16.1	40.6	10.8	22.3	28.4	16.9	19.8	2.8
1.0	16.1	40.4	11.0	22.9	28.4	17.0	20.0	2.9
1.5	16.1	40.1	11.5	19.6	28.8	17.2	20.1	2.8
2.0	15.9	39.9	11.5	17.8	29.1	17.4	20.4	2.7
2.5	15.9	39.6	11.2	17.0	29.3	17.7	20.5	2.6
3.0	15.6	39.2	11.0	17.0	29.4	17.6	20.4	2.7
3.5	14.8	39.5	11.0	14.4	29.0	17.1	19.8	2.6
4.0	14.4	39.7	11.3	12.9	28.7	16.9	19.8	2.6
4.5	14.2	40.0	11.6	12.6	29.0	16.8	19.6	2.6
5.0	14.1	40.4	12.2	12.8	28.6	16.9	19.7	2.6
5.5	14.0	41.0	12.8	12.9	28.6	16.9	19.6	2.6
6.0	13.9	41.3	13.3	12.9	28.3	17.0	19.8	2.6
6.5	13.9	41.9	13.5	12.9	28.7	16.7	19.3	2.6
7.0	13.9	42.3	13.2	13.0	28.4	16.6	19.2	2.5
7.5	13.9	42.5	13.3	13.1	28.0	16.7	19.4	2.7
8.0	14.0	42.6	14.2	13.2	27.8	16.5	19.3	2.6
8.5	14.0	42.4	16.5	13.2	27.4	16.0	18.8	2.5
9.0	14.1	41.8	22.4	13.1	27.4	15.8	18.6	2.5
9.5	14.1	41.4	30.8	12.8	27.8	16.0	18.8	2.7
10.0	13.9	41.1	18.1	12.2	28.1	16.2	18.9	2.6
10.5	13.7	40.9	13.3	11.6	28.0	15.8	18.6	2.9
11.0	13.4	40.9	11.0	11.2	27.7	15.5	18.3	2.7
11.5	13.2	41.0	9.8	11.0	27.7	15.4	18.4	2.8
12.0	13.0	41.0	9.5	11.3	28.3	15.7	18.7	3.0
12.5	13.0	41.2	9.7	11.6	28.2	15.8	18.8	3.0
13.0	13.1	41.3	10.2	12.1	28.0	15.7	18.7	3.1
13.5	13.3	41.3	10.8	12.6	28.1	15.8	18.8	3.1
14.0	13.5	39.3	12.2	14.0	28.1	15.8	18.9	3.1
14.5	13.5	38.6	14.9	15.7	27.7	15.7	18.8	3.2
15.0	13.5	38.8	17.8	18.1	28.0	15.5	18.5	3.2
15.5	13.4	38.9	20.9	20.8	28.0	15.3	18.3	3.2
16.0	13.3	38.9	22.0	23.3	27.2	15.5	18.4	3.4
16.5	13.2	38.8	21.4	24.5	27.4	15.2	18.1	3.4
17.0	13.1	38.5	21.5	23.8	27.4	14.8	17.8	3.5
17.5	13.0	38.4	20.4	21.1	27.2	14.8	17.8	3.7
18.0	12.9	38.2	17.9	18.3	27.4	14.8	18.0	3.7
18.5	12.8	37.8	15.7	15.4	26.9	14.6	18.1	3.8
19.0	12.7	37.6	13.9	13.4	26.4	14.4	18.0	3.8
19.5	12.6	37.0	12.5	12.3	26.7	14.3	18.2	3.9
20.0	12.6	36.7	11.9	11.8	26.4	14.4	18.3	4.2
20.5	12.6	36.2	12.4	12.2	26.0	14.6	18.6	4.1
21.0	12.6	35.8	14.3	13.3	25.9	14.6	18.7	4.1
21.5	12.7	35.1	16.9	15.3	25.8	14.6	18.8	4.2
22.0	12.6	34.4	19.2	17.8	25.6	14.5	19.0	4.3
22.5	12.5	34.1	20.2	20.5	25.6	14.5	18.9	4.4
23.0	12.4	33.7	19.9	24.0	25.4	14.4	18.8	4.5
23.5	12.1	33.6	18.7	24.6	25.2	14.1	18.5	4.6
24.0	12.0	33.6	18.4	22.8	24.5	14.1	18.7	4.8
24.5	11.9	33.5	17.6	19.5	24.3	13.9	18.6	5.0
25.0	11.8	33.2	17.3	17.1	24.0	14.0	18.5	5.1
25.5	11.8	33.1	18.3	15.8	23.8	13.8	18.5	5.2
26.0	11.6	32.8	19.7	15.8	23.6	13.8	18.4	5.3
26.5	11.4	32.5	18.2	17.3	23.2	13.8	18.3	5.3

*Typical Performance Data*

**NOTE: Use PDF Bookmarks to view DATA at required conditions**

**Definitions:**

Input Return Loss = -S11 (dB)

Gain(Power Gain) = S21 (dB)

Reverse Isolation = -S12 (dB)

Output Return Loss = -S22 (dB)

TEST CONDITIONS: V<sub>DD</sub> = +5 V, I<sub>DD</sub> = 23 mA, V<sub>C</sub> = -0.7 V @ Temperature = +25°C

FREQ	Gain	Isolation	Input Return Loss	Output Return Loss	Output IP-3 @ P <sub>OUT</sub> = -9 dBm/Tone	1dB Comp. Output	P <sub>SAT</sub> Output	Noise Figure
(GHz)	(dB)	(dB)	(dB)	(dB)	(dBm)	(dBm)	(dBm)	(dB)
0.3	14.6	42.4	6.1	12.2	5.9	-2.2	0.8	5.8
0.4	14.3	41.3	7.2	15.1	5.7	-2.7	0.2	5.2
0.5	14.6	41.6	8.0	16.9	5.9	-2.5	0.4	4.8
0.6	14.4	40.6	8.6	18.9	5.6	-2.8	0.2	5.6
0.7	14.4	40.3	9.1	21.4	5.5	-2.9	0.1	4.0
0.8	14.4	40.1	9.3	23.7	5.7	-2.8	0.1	3.5
0.9	14.5	40.0	9.5	25.9	5.6	-2.7	0.2	3.4
1.0	14.5	39.8	9.7	26.9	5.7	-2.7	0.2	3.3
1.5	14.4	39.5	10.1	21.2	5.7	-2.6	0.3	3.0
2.0	14.3	39.1	10.1	18.3	6.1	-2.5	0.4	2.8
2.5	14.2	38.6	10.0	16.7	5.9	-2.3	0.6	2.9
3.0	13.9	38.2	10.0	16.8	5.9	-2.5	0.5	3.1
3.5	13.0	38.1	10.2	14.1	5.0	-3.2	0.0	3.1
4.0	12.6	38.4	10.4	12.4	5.0	-3.7	-0.2	3.2
4.5	12.3	38.6	10.6	11.9	5.0	-4.0	-0.2	3.1
5.0	12.1	39.0	10.9	11.9	4.9	-4.1	-0.2	3.5
5.5	11.9	39.4	11.1	12.1	4.7	-4.2	-0.3	3.5
6.0	11.8	39.9	11.4	12.4	4.9	-4.2	-0.3	4.1
6.5	11.7	40.3	11.4	12.6	4.5	-4.3	-0.4	3.7
7.0	11.7	40.7	11.2	12.8	4.4	-4.4	-0.6	3.7
7.5	11.7	40.8	11.1	13.0	4.3	-4.5	-0.6	3.7
8.0	11.8	40.6	11.4	13.2	4.5	-4.5	-0.6	3.7
8.5	11.9	40.2	12.6	13.2	4.0	-4.5	-0.6	3.6
9.0	12.0	39.5	15.5	13.1	4.3	-4.5	-0.6	3.6
9.5	12.1	38.8	22.8	12.9	4.4	-4.3	-0.5	3.6
10.0	12.0	38.2	27.1	12.2	4.4	-4.2	-0.3	3.6
10.5	11.8	37.8	16.4	11.5	4.5	-4.1	0.0	3.9
11.0	11.6	37.7	12.2	11.0	4.5	-4.0	0.9	3.8
11.5	11.3	37.6	10.1	10.8	5.0	-3.9	1.1	4.0
12.0	11.1	37.6	9.3	10.8	5.0	-3.9	2.1	4.4
12.5	10.9	37.6	9.1	11.1	5.0	-4.0	2.9	4.5
13.0	11.0	37.6	9.3	11.6	5.0	-4.1	3.6	4.4
13.5	11.1	37.4	9.8	12.2	5.0	-4.0	4.2	4.5
14.0	11.4	35.8	11.1	13.6	4.9	-4.0	4.6	4.4
14.5	11.5	35.1	13.3	15.6	5.0	-4.0	5.2	4.3
15.0	11.5	35.1	16.9	18.2	5.1	-4.0	5.2	4.4
15.5	11.4	35.2	23.2	21.4	5.0	-4.0	5.6	4.5
16.0	11.3	35.1	34.6	24.3	4.7	-3.9	6.4	4.7
16.5	11.3	34.8	27.9	24.9	4.8	-3.9	5.8	4.7
17.0	11.2	34.6	24.2	23.3	5.0	-3.9	5.6	4.8
17.5	11.1	34.5	24.5	20.9	5.1	-3.7	5.6	5.0
18.0	10.9	34.2	22.3	17.8	4.9	-3.7	5.5	5.2
18.5	10.8	34.0	17.7	14.7	4.7	-3.7	5.3	5.3
19.0	10.6	33.7	14.1	12.5	4.8	-3.8	4.6	5.3
19.5	10.4	33.4	11.9	11.4	4.5	-3.9	6.4	5.5
20.0	10.3	33.1	11.0	10.8	4.6	-3.9	6.3	5.6
20.5	10.4	32.7	11.4	11.0	4.9	-3.9	4.6	5.9
21.0	10.5	32.2	12.9	12.3	5.0	-3.8	4.6	5.9
21.5	10.6	31.7	15.4	14.3	5.0	-3.7	4.6	5.7
22.0	10.6	31.1	19.0	16.6	5.1	-3.5	5.2	5.7
22.5	10.5	30.7	22.5	19.8	5.1	-3.6	4.3	5.8
23.0	10.4	30.4	24.4	23.0	5.2	-3.5	2.0	6.1
23.5	10.2	30.3	23.5	23.7	5.1	-3.4	3.6	6.1
24.0	10.1	30.3	20.8	22.1	5.1	-3.5	2.7	6.2
24.5	9.9	30.1	18.1	18.9	5.0	-3.7	3.5	6.4
25.0	9.8	30.0	16.4	16.0	5.0	-3.7	2.0	6.4
25.5	9.8	29.8	15.8	14.6	5.0	-3.7	2.0	6.9
26.0	9.6	29.5	16.2	14.4	5.0	-3.7	0.9	7.3
26.5	9.6	29.2	16.4	15.0	5.0	-3.7	1.3	7.1

*Typical Performance Data*

**NOTE: Use PDF Bookmarks to view DATA at required conditions**

**Definitions:**

Input Return Loss = -S11 (dB)

Gain(Power Gain) = S21 (dB)

Reverse Isolation = -S12 (dB)

Output Return Loss = -S22 (dB)

TEST CONDITIONS: V<sub>DD</sub> = +5 V, I<sub>DD</sub> = 51 mA, V<sub>C</sub> = +1 V @ Temperature = +25°C

FREQ	Gain	Isolation	Input Return Loss	Output Return Loss	Output IP-3 @ P <sub>OUT</sub> = -9 dBm/Tone	1dB Comp. Output	P <sub>SAT</sub> Output	Noise Figure
(GHz)	(dB)	(dB)	(dB)	(dB)	(dBm)	(dBm)	(dBm)	(dB)
0.3	16.0	43.5	6.2	11.7	24.9	14.4	17.3	4.1
0.4	15.6	42.1	7.6	14.6	24.3	14.0	17.2	3.6
0.5	15.9	42.4	8.5	16.3	23.7	14.2	17.5	3.3
0.6	15.8	41.3	9.2	18.2	24.7	14.2	17.3	4.8
0.7	15.8	41.0	9.8	20.5	24.7	14.1	17.5	2.9
0.8	15.8	40.7	10.1	22.5	24.5	14.3	17.5	2.6
0.9	15.8	40.6	10.4	24.6	25.1	14.3	17.6	2.6
1.0	15.9	40.5	10.6	25.7	24.7	14.4	17.7	2.5
1.5	15.8	40.2	11.0	21.2	25.3	14.6	17.9	2.3
2.0	15.7	39.9	11.0	18.4	25.6	14.9	18.1	2.1
2.5	15.7	39.6	10.9	16.9	25.6	15.1	18.4	2.1
3.0	15.3	39.3	10.9	16.8	25.9	15.1	18.3	2.2
3.5	14.6	39.3	11.0	14.1	24.7	14.5	17.8	2.1
4.0	14.1	39.5	11.2	12.4	24.8	14.3	17.6	2.1
4.5	13.9	39.8	11.4	12.0	25.0	14.2	17.7	2.0
5.0	13.7	40.2	11.7	11.9	24.7	14.3	17.7	2.1
5.5	13.6	40.7	12.0	12.1	24.6	14.2	17.7	2.2
6.0	13.5	41.2	12.2	12.3	25.2	14.3	17.6	2.3
6.5	13.5	41.7	12.3	12.5	24.4	14.2	17.6	2.1
7.0	13.4	42.2	12.1	12.7	24.4	14.1	17.4	2.0
7.5	13.5	42.5	12.0	12.8	24.1	14.0	17.5	2.0
8.0	13.5	42.5	12.4	12.9	24.2	13.9	17.3	2.0
8.5	13.6	42.1	13.8	12.9	23.5	13.7	17.0	1.9
9.0	13.7	41.5	17.2	12.8	23.7	13.6	16.9	1.9
9.5	13.8	40.8	27.3	12.7	23.9	13.7	17.2	1.9
10.0	13.7	40.4	25.3	12.1	23.7	13.5	17.0	1.9
10.5	13.5	40.0	15.8	11.5	23.8	13.4	16.6	2.0
11.0	13.3	39.9	12.0	11.0	23.7	13.4	16.7	2.1
11.5	13.0	39.9	10.1	10.8	24.3	13.6	16.9	2.1
12.0	12.8	39.9	9.4	10.8	24.2	13.5	16.9	2.3
12.5	12.7	40.1	9.3	11.1	24.3	13.5	17.3	2.3
13.0	12.8	40.2	9.6	11.5	24.3	13.6	17.5	2.3
13.5	13.0	40.0	10.1	12.1	24.5	13.7	17.3	2.4
14.0	13.2	38.1	11.5	13.3	24.7	13.7	17.4	2.4
14.5	13.4	37.2	14.0	15.3	23.7	13.7	17.5	2.4
15.0	13.4	37.5	17.8	17.8	23.7	13.7	17.4	2.4
15.5	13.3	37.6	23.8	20.8	25.3	13.6	17.3	2.4
16.0	13.3	37.6	28.7	23.4	23.3	13.4	17.4	2.5
16.5	13.2	37.3	25.5	23.9	23.0	13.2	17.1	2.5
17.0	13.2	37.1	23.6	22.3	23.2	13.0	16.7	2.6
17.5	13.0	37.0	23.1	20.3	23.5	12.8	16.5	2.7
18.0	12.9	36.7	20.7	17.7	23.1	12.5	16.1	2.8
18.5	12.8	36.4	16.7	14.7	22.2	12.2	15.9	2.8
19.0	12.6	36.2	13.6	12.6	22.4	12.1	16.2	2.9
19.5	12.5	35.8	11.7	11.6	21.9	12.1	16.5	3.0
20.0	12.4	35.4	10.9	10.9	22.1	12.0	16.7	3.1
20.5	12.5	35.0	11.5	11.1	21.8	12.1	16.9	3.2
21.0	12.6	34.4	13.0	12.4	21.8	12.1	17.3	3.3
21.5	12.7	33.8	15.4	14.3	21.9	12.2	17.5	3.2
22.0	12.7	33.2	18.6	16.6	22.1	12.0	17.7	3.2
22.5	12.7	32.7	21.1	19.8	21.9	12.0	17.8	3.3
23.0	12.6	32.4	22.0	23.2	21.8	12.0	17.8	3.4
23.5	12.4	32.3	21.2	24.0	21.2	11.8	17.6	3.4
24.0	12.3	32.2	19.1	22.5	21.2	11.6	17.8	3.4
24.5	12.2	32.1	17.1	19.4	20.7	11.4	17.8	3.6
25.0	12.1	31.8	16.0	16.3	20.6	11.4	17.8	3.7
25.5	12.1	31.6	16.1	14.8	20.7	11.3	17.6	3.8
26.0	12.0	31.3	17.4	14.6	20.5	11.2	17.6	4.1
26.5	11.9	31.0	17.8	15.1	20.2	11.0	17.7	4.1

*Typical Performance Data*

**NOTE: Use PDF Bookmarks to view DATA at required conditions**

**Definitions:**

Input Return Loss = -S11 (dB)

Gain(Power Gain) = S21 (dB)

Reverse Isolation = -S12 (dB)

Output Return Loss = -S22 (dB)

TEST CONDITIONS: V<sub>DD</sub> = +5 V, I<sub>DD</sub> = 82 mA, V<sub>C</sub> = +2 V @ Temperature = +25°C

FREQ	Gain	Isolation	Input Return Loss	Output Return Loss	Output IP-3 @ P <sub>OUT</sub> = -9 dBm/Tone	1dB Comp. Output	P <sub>SAT</sub> Output	Noise Figure
(GHz)	(dB)	(dB)	(dB)	(dB)	(dBm)	(dBm)	(dBm)	(dB)
0.3	16.8	44.2	6.4	11.6	25.9	15.5	18.9	3.9
0.4	16.4	42.7	7.9	14.4	25.9	15.2	18.9	3.5
0.5	16.7	43.0	8.9	16.1	25.5	15.4	19.2	3.2
0.6	16.6	41.8	9.7	17.9	26.3	15.4	19.1	4.9
0.7	16.6	41.5	10.4	20.1	26.2	15.5	19.2	2.8
0.8	16.6	41.3	10.8	22.0	26.2	15.6	19.3	2.5
0.9	16.6	41.2	11.1	23.9	26.5	15.7	19.4	2.5
1.0	16.7	41.1	11.3	24.9	26.4	15.8	19.4	2.4
1.5	16.6	40.8	11.8	21.0	26.8	16.0	19.7	2.3
2.0	16.6	40.7	11.7	18.4	27.3	16.4	19.9	2.1
2.5	16.5	40.4	11.6	16.9	27.3	16.6	20.3	2.1
3.0	16.2	40.1	11.5	16.8	27.4	16.6	20.2	2.2
3.5	15.5	40.1	11.6	14.0	26.7	16.1	19.7	2.1
4.0	15.1	40.5	11.8	12.4	26.9	15.9	19.4	2.1
4.5	14.9	40.9	12.0	12.0	26.9	15.8	19.5	2.0
5.0	14.7	41.3	12.3	11.9	27.1	15.9	19.6	2.1
5.5	14.6	41.9	12.7	12.1	26.9	15.9	19.6	2.1
6.0	14.5	42.4	13.0	12.3	27.4	16.0	19.4	2.2
6.5	14.5	42.9	13.2	12.5	26.7	15.8	19.4	2.0
7.0	14.5	43.5	13.1	12.6	26.8	15.7	19.2	1.9
7.5	14.6	43.9	13.1	12.7	26.1	15.6	19.3	1.9
8.0	14.6	43.9	13.6	12.7	26.3	15.5	19.1	1.9
8.5	14.7	43.7	15.3	12.7	25.7	15.1	18.7	1.8
9.0	14.8	43.2	19.5	12.7	25.6	15.0	18.5	1.9
9.5	14.8	42.6	31.0	12.5	25.8	15.1	18.8	1.9
10.0	14.7	42.2	21.4	12.0	25.7	15.0	18.6	1.9
10.5	14.5	41.9	14.9	11.4	25.6	14.7	18.2	2.0
11.0	14.2	41.9	11.7	11.0	25.5	14.8	18.2	2.0
11.5	14.0	41.9	10.1	10.8	26.4	15.1	18.4	2.1
12.0	13.8	42.1	9.5	10.8	26.2	14.9	18.4	2.2
12.5	13.7	42.3	9.5	11.1	26.4	14.9	18.8	2.3
13.0	13.8	42.6	9.8	11.5	26.3	15.1	19.1	2.3
13.5	14.0	42.4	10.4	11.9	26.5	15.1	18.9	2.3
14.0	14.3	40.0	11.8	13.2	27.2	15.1	18.9	2.3
14.5	14.5	39.1	14.6	15.1	25.0	15.1	19.1	2.3
15.0	14.5	39.5	18.1	17.6	25.8	15.1	19.0	2.4
15.5	14.4	39.7	22.3	20.5	27.8	14.9	18.9	2.4
16.0	14.3	39.7	23.9	23.0	24.7	14.9	19.0	2.5
16.5	14.3	39.6	23.1	23.3	24.6	14.7	18.7	2.5
17.0	14.2	39.4	22.5	21.8	25.1	14.4	18.2	2.5
17.5	14.1	39.3	21.8	19.9	25.3	14.4	18.1	2.6
18.0	14.0	39.0	19.2	17.5	25.4	14.1	17.7	2.7
18.5	13.9	38.7	15.7	14.7	24.8	13.8	17.5	2.8
19.0	13.7	38.5	13.1	12.7	24.5	13.7	17.8	2.9
19.5	13.6	38.1	11.5	11.7	24.0	13.7	18.0	3.0
20.0	13.6	37.6	10.9	11.0	24.6	13.6	18.1	3.1
20.5	13.6	37.1	11.5	11.2	24.0	13.6	18.4	3.1
21.0	13.7	36.5	12.9	12.4	23.5	13.8	18.8	3.2
21.5	13.8	35.8	15.1	14.3	24.0	13.8	19.0	3.2
22.0	13.8	35.2	17.5	16.6	24.2	13.7	19.1	3.2
22.5	13.8	34.6	19.2	19.9	24.0	13.6	19.2	3.2
23.0	13.7	34.3	20.1	23.5	23.7	13.6	19.2	3.3
23.5	13.5	34.2	19.6	24.1	22.8	13.4	19.0	3.4
24.0	13.4	34.0	17.9	22.7	23.1	13.2	19.3	3.4
24.5	13.3	33.9	16.4	19.7	22.5	13.0	19.3	3.5
25.0	13.3	33.6	16.0	16.6	22.4	13.0	19.2	3.6
25.5	13.3	33.4	16.7	15.0	22.4	12.9	19.0	3.8
26.0	13.1	33.1	18.6	14.7	22.1	12.7	19.0	4.1
26.5	13.1	32.7	18.7	15.2	22.0	12.6	19.1	4.1

*Typical Performance Data*

**NOTE: Use PDF Bookmarks to view DATA at required conditions**

**Definitions:**

- Input Return Loss = -S11 (dB)
- Gain(Power Gain) = S21 (dB)
- Reverse Isolation = -S12 (dB)
- Output Return Loss = -S22 (dB)

TEST CONDITIONS:  $V_D = +8\text{ V}$ ,  $I_D = 80\text{ mA}$ ,  $V_C = \text{Open}$  @ Temperature = +25°C

FREQ	Gain	Isolation	Input Return Loss	Output Return Loss	Output IP-3 @ P <sub>OUT</sub> = 0 dBm/Tone	1dB Comp. Output	P <sub>SAT</sub> Output	Noise Figure
(GHz)	(dB)	(dB)	(dB)	(dB)	(dBm)	(dBm)	(dBm)	(dB)
0.3	16.7	44.2	6.5	11.3	26.5	14.9	17.9	3.9
0.4	16.4	42.7	8.0	14.1	26.5	14.8	17.7	3.5
0.5	16.7	42.9	9.0	15.9	26.4	15.0	18.0	3.0
0.6	16.6	41.8	9.8	17.8	26.9	15.0	17.9	3.8
0.7	16.6	41.6	10.5	20.1	27.0	15.1	18.0	2.7
0.8	16.6	41.3	10.8	21.9	27.0	15.1	18.1	2.7
0.9	16.7	41.2	11.2	23.6	27.2	15.3	18.2	2.5
1.0	16.7	41.1	11.4	24.4	27.2	15.4	18.2	2.5
1.5	16.7	40.8	11.9	20.3	27.6	15.7	18.5	2.3
2.0	16.7	40.6	11.9	17.3	27.8	16.0	18.8	2.1
2.5	16.6	40.3	11.8	16.1	28.1	16.2	18.8	2.1
3.0	16.4	40.0	11.7	15.8	28.3	16.2	18.8	2.2
3.5	15.7	40.0	11.9	13.2	27.7	15.8	18.4	2.0
4.0	15.3	40.4	12.1	11.7	27.8	15.6	18.3	2.1
4.5	15.1	40.7	12.3	11.4	28.0	15.6	18.3	1.9
5.0	14.9	41.1	12.5	11.4	27.6	15.6	18.5	2.0
5.5	14.8	41.6	12.8	11.7	28.0	15.6	18.3	1.9
6.0	14.8	42.1	13.1	12.0	27.7	15.7	18.4	2.0
6.5	14.8	42.7	13.3	12.4	28.0	15.6	18.3	2.0
7.0	14.8	43.1	13.2	12.6	27.7	15.4	18.2	1.9
7.5	14.8	43.4	13.2	12.8	26.9	15.3	18.2	1.9
8.0	14.8	43.4	13.6	13.0	26.9	15.0	17.9	1.9
8.5	14.9	43.1	15.3	13.1	27.0	14.9	17.8	1.9
9.0	15.0	42.7	19.1	13.0	26.7	14.8	17.6	1.9
9.5	15.0	42.0	28.7	12.8	26.7	14.5	17.4	1.9
10.0	15.0	41.6	22.0	12.3	26.7	14.5	17.4	2.0
10.5	14.7	41.4	15.3	11.7	26.7	14.5	17.5	2.1
11.0	14.6	41.2	11.1	11.2	27.0	14.6	17.5	2.0
11.5	14.3	41.3	10.4	11.0	27.1	14.3	17.3	2.1
12.0	14.1	41.4	9.6	11.1	26.6	14.2	17.3	2.3
12.5	14.0	41.7	9.4	11.3	27.0	14.5	17.6	2.2
13.0	14.1	42.0	9.7	11.7	27.4	14.7	17.8	2.3
13.5	14.3	41.8	10.4	12.4	27.2	14.6	17.8	2.4
14.0	14.6	39.5	11.8	13.8	26.6	14.6	17.9	2.4
14.5	14.7	38.6	14.4	16.1	27.0	14.6	18.0	2.4
15.0	14.7	38.9	17.9	19.1	27.5	14.8	18.1	2.4
15.5	14.6	39.3	21.7	22.2	27.1	14.7	17.9	2.4
16.0	14.6	39.4	23.9	24.4	26.6	14.3	17.6	2.5
16.5	14.5	39.1	23.5	23.8	26.7	14.2	17.6	2.5
17.0	14.5	38.9	23.4	21.9	26.5	14.0	17.4	2.6
17.5	14.4	38.8	23.1	19.7	26.3	14.1	17.2	2.6
18.0	14.3	38.6	20.0	17.3	26.2	13.7	16.7	2.8
18.5	14.2	38.3	16.0	15.1	25.7	13.2	16.1	2.8
19.0	14.0	37.9	13.1	13.2	25.6	13.2	15.9	2.8
19.5	13.9	37.7	11.5	11.9	25.7	13.4	16.1	3.1
20.0	13.8	37.3	10.9	11.2	25.6	13.4	16.3	3.1
20.5	13.8	36.9	11.3	11.3	25.3	13.3	16.4	3.2
21.0	13.9	36.4	12.5	12.2	25.2	13.2	16.5	3.2
21.5	14.0	35.8	14.4	13.9	25.3	13.4	16.7	3.3
22.0	14.1	35.2	16.7	16.2	25.1	13.4	16.9	3.3
22.5	14.1	34.7	18.6	18.1	24.9	13.3	16.9	3.3
23.0	14.1	34.2	19.8	19.3	24.9	13.1	16.9	3.3
23.5	14.0	33.9	19.8	19.9	24.3	12.7	16.7	3.4
24.0	13.8	33.8	18.5	19.5	24.2	12.8	16.9	3.5
24.5	13.7	33.6	17.1	17.9	24.1	12.8	16.9	3.6
25.0	13.6	33.5	16.3	15.9	23.5	12.4	16.9	3.7
25.5	13.6	33.3	16.9	14.4	23.8	12.4	16.7	3.9
26.0	13.4	33.0	17.9	13.9	23.6	12.1	16.6	4.0
26.5	13.3	32.8	17.3	14.4	23.1	12.1	16.8	4.2

*Typical Performance Data*

**NOTE: Use PDF Bookmarks to view DATA at required conditions**

**Definitions:**

Input Return Loss = -S11 (dB)

Gain(Power Gain) = S21 (dB)

Reverse Isolation = -S12 (dB)

Output Return Loss = -S22 (dB)

TEST CONDITIONS:  $V_D = +8\text{ V}$ ,  $I_D = 37\text{ mA}$ ,  $V_C = -0.7\text{ V}$  @ Temperature = +25°C

FREQ	Gain	Isolation	Input Return Loss	Output Return Loss	Output IP-3 @ P <sub>OUT</sub> = -9 dBm/Tone	1dB Comp. Output	P <sub>SAT</sub> Output	Noise Figure
(GHz)	(dB)	(dB)	(dB)	(dB)	(dBm)	(dBm)	(dBm)	(dB)
0.3	15.2	35.2	6.0	14.1	17.2	6.5	9.4	7.5
0.4	14.8	36.1	6.7	15.9	16.8	5.9	9.0	6.7
0.5	15.0	37.0	7.4	18.7	16.7	6.0	9.1	5.9
0.6	14.8	37.7	7.9	19.2	16.8	5.8	8.9	5.9
0.7	14.7	38.2	8.4	19.6	16.7	5.7	8.9	4.9
0.8	14.6	38.7	8.7	20.3	16.7	5.6	8.8	4.5
0.9	14.7	38.7	8.9	19.6	16.7	5.7	8.9	4.2
1.0	14.7	38.8	9.1	19.1	16.7	5.7	8.9	4.1
1.5	14.6	38.9	9.5	16.4	16.8	5.8	9.0	3.4
2.0	14.4	38.6	9.6	14.7	16.7	6.0	9.2	3.1
2.5	14.3	38.2	9.6	14.0	16.7	6.0	9.3	3.0
3.0	13.9	37.8	9.6	13.8	16.3	5.8	9.3	2.9
3.5	13.1	37.6	9.8	11.9	15.9	5.4	8.9	2.8
4.0	12.7	37.9	10.1	10.7	15.9	5.2	8.8	2.8
4.5	12.4	38.3	10.3	10.5	16.2	5.1	8.9	2.6
5.0	12.2	38.7	10.6	10.6	15.7	5.0	9.0	2.7
5.5	12.0	39.2	10.9	10.9	15.9	4.9	9.0	2.6
6.0	11.9	39.7	11.2	11.3	15.4	4.9	9.1	2.8
6.5	11.9	40.2	11.4	11.7	15.9	4.8	9.0	2.7
7.0	11.9	40.5	11.4	12.0	15.7	4.8	9.0	2.7
7.5	11.9	40.5	11.4	12.4	15.2	4.8	9.1	2.7
8.0	12.0	40.2	11.9	12.7	15.4	4.8	9.1	2.7
8.5	12.1	39.7	13.5	13.1	15.1	4.7	8.9	2.7
9.0	12.2	38.9	17.3	13.4	15.1	4.6	8.9	2.7
9.5	12.2	38.1	27.8	13.4	15.1	4.5	8.7	2.7
10.0	12.1	37.6	21.5	12.9	15.0	4.6	8.8	2.9
10.5	11.8	37.3	14.4	12.1	14.9	4.5	8.8	2.9
11.0	11.7	37.1	10.2	11.5	14.7	4.3	8.7	2.9
11.5	11.3	37.1	9.5	11.1	14.7	4.3	8.6	3.0
12.0	11.0	37.2	8.8	11.0	14.0	4.3	8.6	3.3
12.5	10.9	37.2	8.7	11.2	14.6	4.3	8.6	3.2
13.0	11.0	37.2	9.0	11.6	15.4	4.4	8.6	3.4
13.5	11.2	36.9	9.8	12.4	15.1	4.6	8.8	3.5
14.0	11.4	35.4	11.3	13.9	14.4	4.7	9.0	3.4
14.5	11.6	34.5	13.8	16.1	15.0	4.6	9.0	3.5
15.0	11.5	34.4	17.7	19.1	15.2	4.5	9.1	3.4
15.5	11.4	34.5	23.7	22.2	14.6	4.3	9.2	3.5
16.0	11.3	34.4	27.4	24.4	14.3	4.1	9.4	3.5
16.5	11.2	34.1	25.5	23.9	14.1	3.9	9.0	3.5
17.0	11.1	33.8	24.2	22.5	13.8	3.7	8.9	3.7
17.5	10.9	33.6	23.8	20.7	13.6	3.5	8.9	3.7
18.0	10.8	33.4	20.2	18.3	13.5	3.3	8.9	3.9
18.5	10.6	33.2	15.9	15.6	13.0	3.2	8.7	4.1
19.0	10.4	32.9	13.0	13.3	13.0	3.1	8.6	4.1
19.5	10.2	32.7	11.3	11.8	13.0	3.0	8.6	4.3
20.0	10.0	32.4	10.7	11.0	12.8	3.0	8.3	4.4
20.5	10.0	32.1	11.3	11.1	13.0	3.0	7.6	4.5
21.0	10.1	31.6	12.8	12.0	13.1	3.0	7.5	4.5
21.5	10.2	31.1	15.2	13.7	13.2	3.0	7.6	4.7
22.0	10.2	30.6	18.2	15.9	12.9	2.9	7.6	4.6
22.5	10.1	30.3	21.2	17.8	12.7	2.9	7.8	4.6
23.0	10.0	30.0	23.1	19.0	12.6	2.7	8.0	4.7
23.5	9.8	29.7	22.7	19.2	12.4	2.6	8.2	4.9
24.0	9.6	29.6	20.4	18.6	12.2	2.4	8.5	4.9
24.5	9.4	29.6	17.9	17.2	12.1	2.3	8.6	4.9
25.0	9.2	29.4	16.5	15.6	11.7	2.2	8.6	5.1
25.5	9.1	29.3	16.6	14.6	11.8	2.0	7.7	5.3
26.0	8.9	29.2	17.1	14.3	11.9	1.8	7.5	5.5
26.5	8.7	29.0	16.9	14.7	11.3	1.6	7.6	5.7

*Typical Performance Data*

**NOTE: Use PDF Bookmarks to view DATA at required conditions**

**Definitions:**

- Input Return Loss = -S11 (dB)
- Gain(Power Gain) = S21 (dB)
- Reverse Isolation = -S12 (dB)
- Output Return Loss = -S22 (dB)

TEST CONDITIONS:  $V_D = +8\text{ V}$ ,  $I_D = 58\text{ mA}$ ,  $V_C = +1\text{ V}$  @ Temperature = +25°C

FREQ	Gain	Isolation	Input Return Loss	Output Return Loss	Output IP-3 @ P <sub>OUT</sub> = -9 dBm/Tone	1dB Comp. Output	P <sub>SAT</sub> Output	Noise Figure
(GHz)	(dB)	(dB)	(dB)	(dB)	(dBm)	(dBm)	(dBm)	(dB)
0.3	16.2	43.9	6.4	11.5	25.7	14.2	17.5	4.7
0.4	15.9	42.5	7.7	14.5	25.0	13.7	17.3	4.2
0.5	16.2	42.9	8.7	16.3	24.4	13.8	17.6	3.6
0.6	16.0	41.7	9.4	18.3	25.7	13.8	17.5	4.2
0.7	16.0	41.5	10.0	20.8	25.5	13.9	17.5	3.1
0.8	16.1	41.2	10.3	22.9	25.2	13.9	17.6	3.0
0.9	16.1	41.1	10.6	24.8	25.8	14.0	17.7	2.8
1.0	16.1	41.0	10.8	25.5	25.5	14.0	17.8	2.8
1.5	16.2	40.6	11.2	20.3	26.5	14.3	18.0	2.4
2.0	16.1	40.4	11.2	17.2	25.9	14.5	18.3	2.2
2.5	16.0	40.1	11.2	16.0	26.9	14.9	18.4	2.2
3.0	15.8	39.8	11.1	15.7	26.7	15.0	18.3	2.2
3.5	15.0	39.8	11.3	13.2	25.7	14.4	17.9	2.1
4.0	14.6	40.1	11.5	11.7	25.9	14.1	17.8	2.1
4.5	14.4	40.5	11.8	11.3	25.9	14.2	17.8	2.0
5.0	14.2	40.9	12.0	11.4	25.4	14.0	17.9	2.0
5.5	14.1	41.4	12.2	11.6	25.7	14.2	17.8	2.0
6.0	14.0	41.9	12.5	12.0	25.5	14.2	17.9	2.1
6.5	14.0	42.5	12.6	12.4	25.7	14.0	17.8	2.0
7.0	14.0	43.0	12.5	12.7	25.5	14.0	17.6	2.0
7.5	14.0	43.2	12.4	12.9	24.8	13.9	17.6	2.0
8.0	14.0	43.2	12.8	13.1	24.7	13.8	17.4	2.0
8.5	14.1	42.8	14.3	13.3	24.7	13.5	17.3	1.9
9.0	14.2	42.2	17.8	13.3	24.5	13.4	17.2	1.9
9.5	14.3	41.5	27.9	13.0	24.8	13.3	17.0	1.9
10.0	14.2	41.0	24.3	12.5	24.8	13.4	17.0	2.0
10.5	14.0	40.7	15.8	11.9	24.9	13.5	17.1	2.1
11.0	13.9	40.5	11.1	11.3	25.1	13.5	17.0	2.1
11.5	13.6	40.5	10.3	11.1	25.2	13.4	16.9	2.1
12.0	13.3	40.6	9.5	11.1	24.5	13.4	16.9	2.3
12.5	13.2	40.7	9.3	11.4	25.1	13.4	17.3	2.3
13.0	13.3	40.9	9.5	11.8	25.3	13.5	17.5	2.4
13.5	13.5	40.6	10.2	12.5	25.4	13.6	17.4	2.5
14.0	13.8	38.5	11.5	14.0	25.0	13.6	17.5	2.5
14.5	13.9	37.6	14.1	16.3	24.6	13.5	17.6	2.4
15.0	13.9	37.8	17.7	19.5	24.5	13.5	17.8	2.4
15.5	13.8	38.1	22.7	22.9	26.4	13.4	17.6	2.5
16.0	13.7	38.1	26.5	25.1	24.0	13.3	17.3	2.5
16.5	13.7	37.9	25.2	24.4	23.9	13.1	17.3	2.5
17.0	13.6	37.6	24.5	22.6	24.3	12.8	17.1	2.6
17.5	13.5	37.4	24.3	20.4	24.1	12.6	16.9	2.7
18.0	13.4	37.1	21.1	17.9	24.4	12.3	16.4	2.8
18.5	13.3	36.8	16.6	15.4	23.3	11.9	15.7	2.9
19.0	13.1	36.5	13.4	13.3	23.6	11.8	15.6	2.9
19.5	13.0	36.2	11.6	11.9	23.4	11.7	15.9	3.1
20.0	12.9	35.9	10.9	11.1	23.4	11.7	16.1	3.2
20.5	12.9	35.5	11.3	11.2	22.7	11.6	16.3	3.3
21.0	13.0	34.9	12.5	12.1	22.7	11.7	16.5	3.3
21.5	13.1	34.3	14.6	13.7	23.3	11.7	16.8	3.4
22.0	13.1	33.7	17.3	16.0	23.3	11.9	16.8	3.3
22.5	13.1	33.2	19.8	18.0	23.0	11.9	16.8	3.4
23.0	13.1	32.8	21.4	19.3	22.8	11.7	16.9	3.4
23.5	13.0	32.5	21.3	19.9	22.1	11.6	16.8	3.5
24.0	12.8	32.4	19.6	19.7	22.3	11.5	16.9	3.5
24.5	12.7	32.2	17.5	18.1	21.8	11.4	16.9	3.6
25.0	12.6	32.0	16.3	15.9	21.4	11.4	16.8	3.7
25.5	12.5	31.8	16.4	14.4	21.9	11.4	16.8	3.9
26.0	12.4	31.6	17.1	13.8	21.8	11.4	16.7	4.1
26.5	12.3	31.4	16.9	14.2	21.3	11.2	16.8	4.2

*Typical Performance Data*

**NOTE: Use PDF Bookmarks to view DATA at required conditions**

**Definitions:**

- Input Return Loss = -S11 (dB)
- Gain(Power Gain) = S21 (dB)
- Reverse Isolation = -S12 (dB)
- Output Return Loss = -S22 (dB)

TEST CONDITIONS:  $V_D = +8\text{ V}$ ,  $I_D = 82\text{ mA}$ ,  $V_C = +2\text{ V}$  @ Temperature = +25°C

FREQ	Gain	Isolation	Input Return Loss	Output Return Loss	Output IP-3 @ P <sub>OUT</sub> = -9 dBm/Tone	1dB Comp. Output	P <sub>SAT</sub> Output	Noise Figure
(GHz)	(dB)	(dB)	(dB)	(dB)	(dBm)	(dBm)	(dBm)	(dB)
0.3	16.7	44.2	6.5	11.2	26.7	14.8	17.9	3.9
0.4	16.4	42.7	8.0	14.0	26.4	14.7	17.8	3.5
0.5	16.7	42.9	9.1	15.8	26.1	15.0	18.0	3.1
0.6	16.6	41.8	9.9	17.7	26.9	14.9	17.9	3.8
0.7	16.6	41.5	10.6	19.9	26.9	15.1	18.0	2.8
0.8	16.6	41.3	10.9	21.8	26.6	15.1	18.1	2.7
0.9	16.6	41.2	11.3	23.5	26.9	15.3	18.2	2.5
1.0	16.7	41.1	11.5	24.2	27.2	15.3	18.3	2.5
1.5	16.7	40.8	12.0	20.3	27.9	15.7	18.5	2.3
2.0	16.7	40.5	11.9	17.3	27.7	16.1	18.8	2.2
2.5	16.6	40.3	11.8	16.2	28.1	16.2	18.9	2.1
3.0	16.4	40.0	11.8	15.8	28.5	16.2	18.8	2.2
3.5	15.7	40.0	11.9	13.2	28.0	15.8	18.4	2.1
4.0	15.3	40.3	12.1	11.7	27.7	15.7	18.3	2.1
4.5	15.1	40.7	12.4	11.4	28.3	15.6	18.3	1.9
5.0	14.9	41.1	12.6	11.4	27.6	15.7	18.5	2.0
5.5	14.8	41.6	12.9	11.7	28.1	15.7	18.3	1.9
6.0	14.8	42.1	13.2	12.1	28.0	15.7	18.4	2.1
6.5	14.8	42.6	13.4	12.4	28.0	15.6	18.4	2.0
7.0	14.8	43.0	13.3	12.6	28.1	15.4	18.2	2.0
7.5	14.8	43.3	13.2	12.8	26.9	15.3	18.2	2.0
8.0	14.8	43.3	13.7	13.0	26.8	14.9	18.0	1.9
8.5	14.9	43.1	15.4	13.1	26.8	14.8	17.8	1.9
9.0	15.0	42.6	19.2	13.0	26.6	14.7	17.7	1.9
9.5	15.0	42.0	28.5	12.8	26.5	14.4	17.4	1.9
10.0	14.9	41.6	21.8	12.3	26.9	14.3	17.4	2.0
10.5	14.7	41.4	15.2	11.7	26.9	14.5	17.5	2.1
11.0	14.6	41.2	11.0	11.2	27.2	14.4	17.5	2.0
11.5	14.3	41.3	10.4	11.0	27.3	14.2	17.3	2.2
12.0	14.1	41.4	9.6	11.0	26.7	14.1	17.3	2.3
12.5	14.0	41.7	9.5	11.3	27.2	14.4	17.6	2.3
13.0	14.0	41.9	9.8	11.7	27.0	14.6	17.8	2.4
13.5	14.3	41.8	10.5	12.4	27.1	14.5	17.8	2.5
14.0	14.5	39.6	11.9	13.8	27.8	14.4	17.9	2.4
14.5	14.7	38.6	14.5	16.0	26.1	14.5	17.9	2.4
15.0	14.7	38.9	17.8	19.1	26.5	14.7	18.0	2.4
15.5	14.6	39.3	21.5	22.2	28.2	14.5	17.8	2.5
16.0	14.5	39.4	23.6	24.4	25.1	14.1	17.5	2.5
16.5	14.5	39.2	23.4	23.8	25.3	14.1	17.4	2.5
17.0	14.4	39.0	23.4	21.9	25.8	13.9	17.3	2.6
17.5	14.3	38.8	23.0	19.7	26.3	13.9	17.2	2.7
18.0	14.2	38.6	19.9	17.3	27.1	13.5	16.7	2.8
18.5	14.1	38.3	15.9	15.0	26.4	12.9	16.1	2.9
19.0	14.0	38.0	13.2	13.1	26.0	13.0	15.9	2.9
19.5	13.8	37.7	11.5	11.8	25.7	13.3	16.0	3.1
20.0	13.7	37.4	10.9	11.2	25.9	13.3	16.1	3.2
20.5	13.8	37.0	11.4	11.3	24.7	13.1	16.2	3.3
21.0	13.9	36.4	12.6	12.2	24.5	13.1	16.3	3.3
21.5	14.0	35.9	14.4	13.9	25.7	13.3	16.5	3.3
22.0	14.0	35.2	16.6	16.2	25.4	13.2	16.6	3.3
22.5	14.0	34.8	18.5	18.2	25.2	13.1	16.6	3.4
23.0	14.0	34.3	19.7	19.4	24.9	12.9	16.5	3.4
23.5	13.9	34.0	19.7	19.9	23.9	12.4	16.5	3.5
24.0	13.7	33.9	18.6	19.5	24.4	12.6	16.6	3.5
24.5	13.6	33.7	17.1	17.8	23.8	12.5	16.6	3.6
25.0	13.5	33.5	16.4	15.8	23.4	12.2	16.6	3.8
25.5	13.5	33.4	17.0	14.4	23.9	12.1	16.4	3.9
26.0	13.3	33.2	17.9	13.9	23.7	11.7	16.3	4.2
26.5	13.2	33.0	17.3	14.4	23.2	11.8	16.5	4.3



## Typical Performance Curves

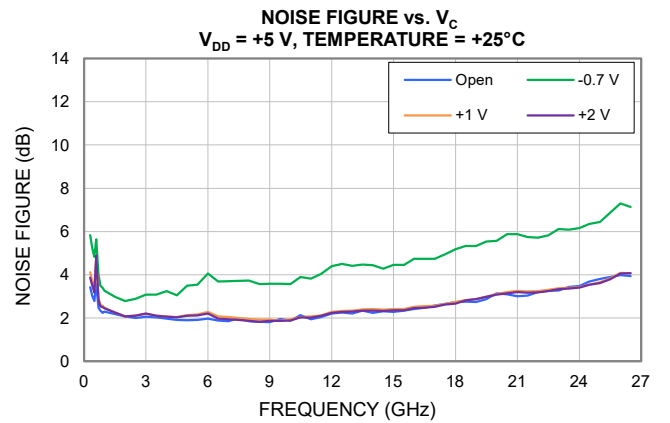
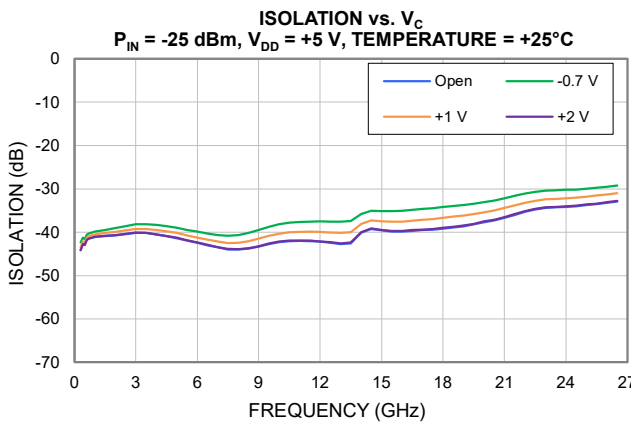
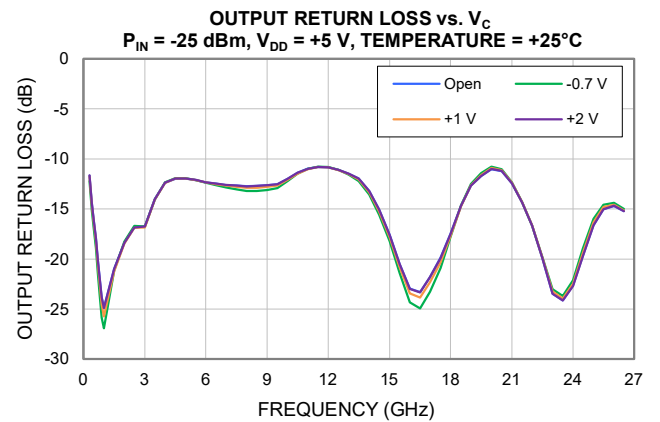
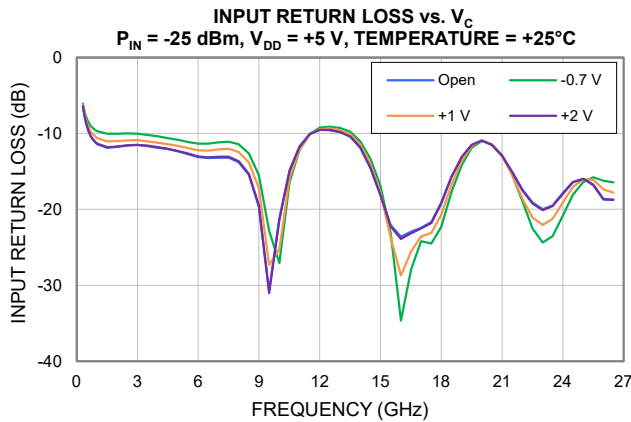
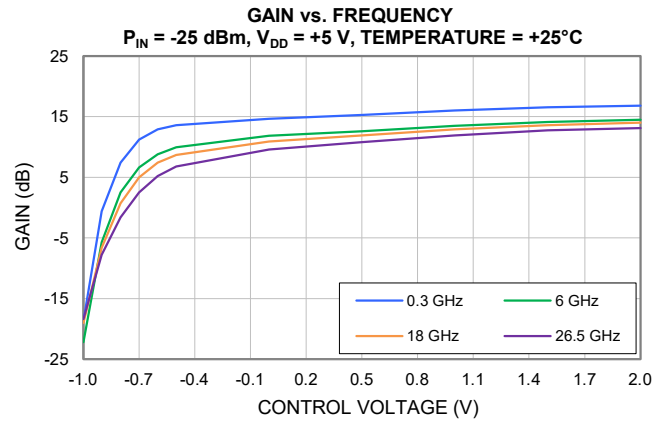
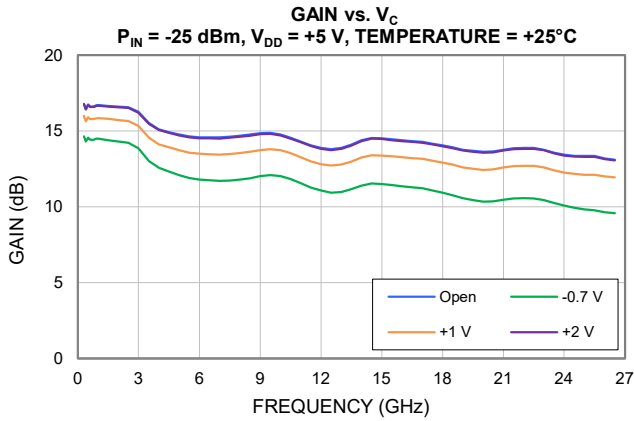

## Typical Performance Curves

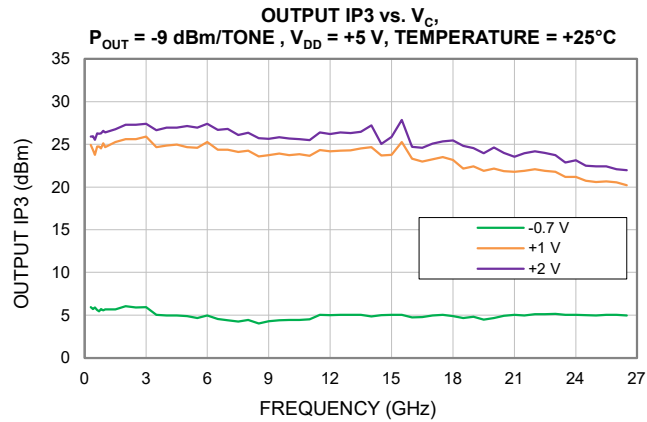
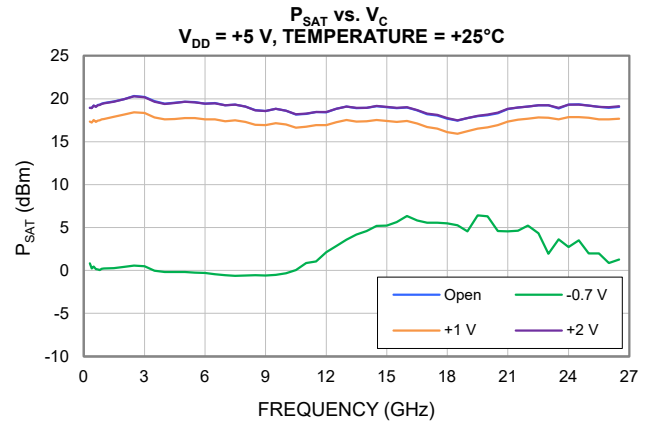
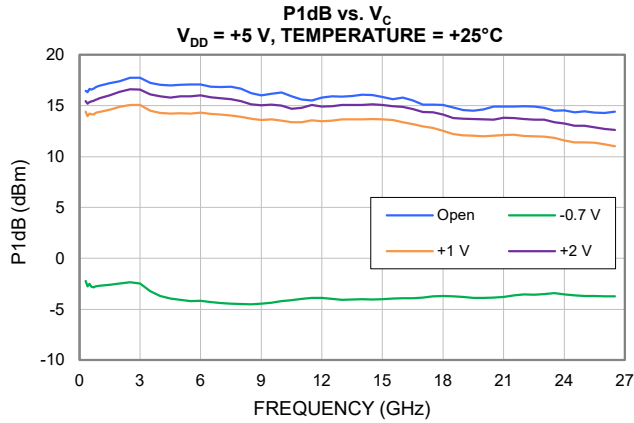

## Typical Performance Curves

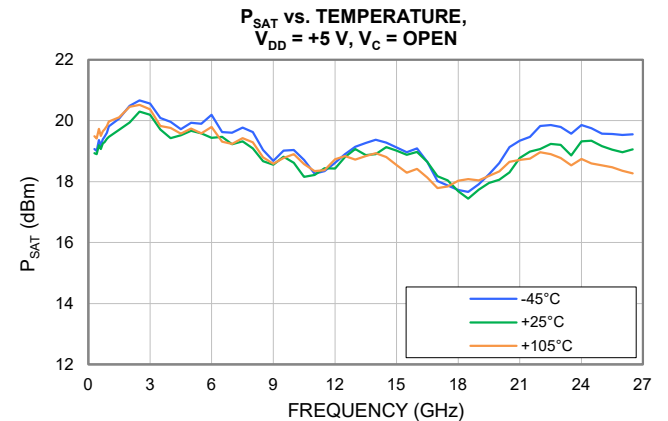
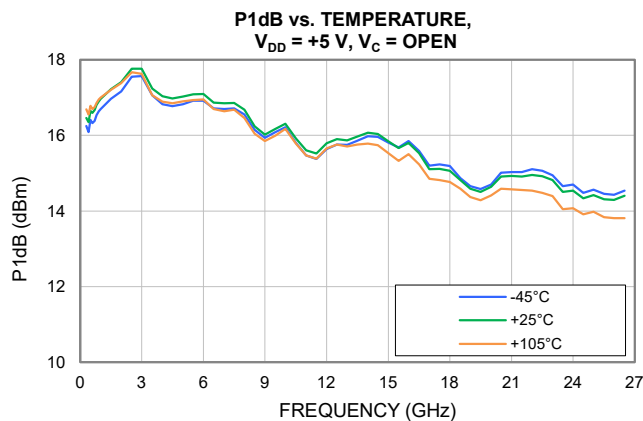
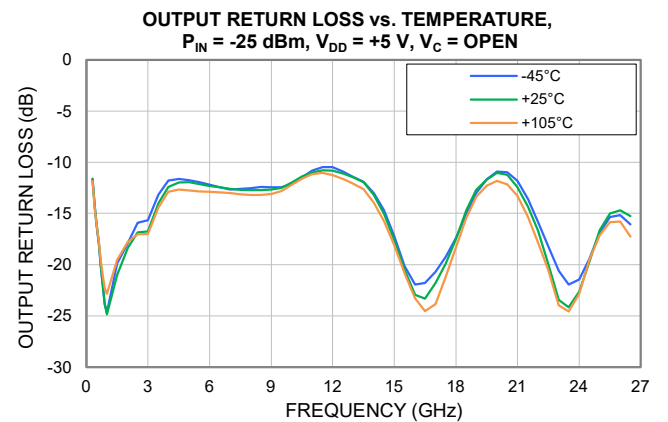
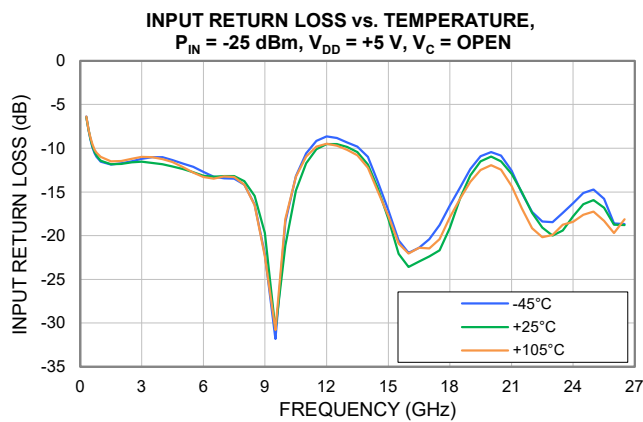
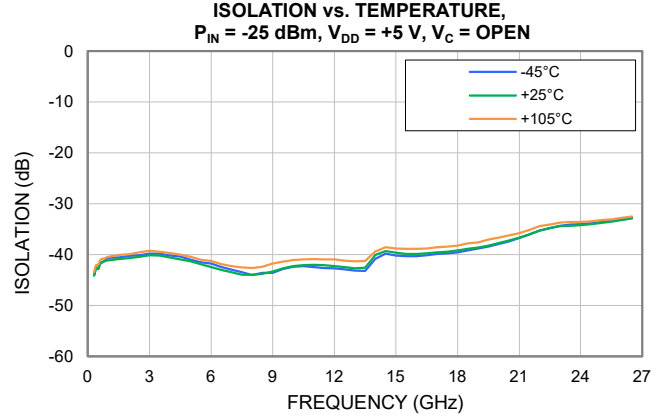
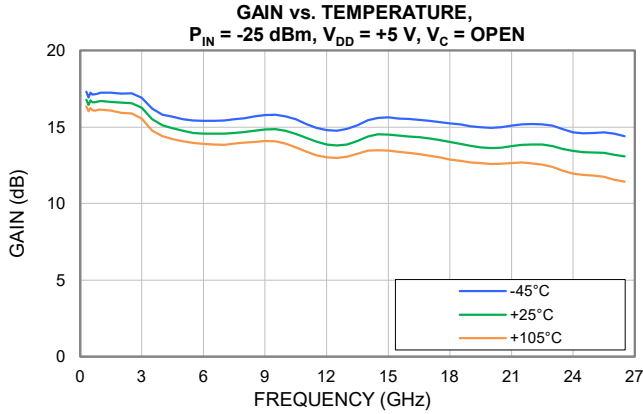

## Typical Performance Curves

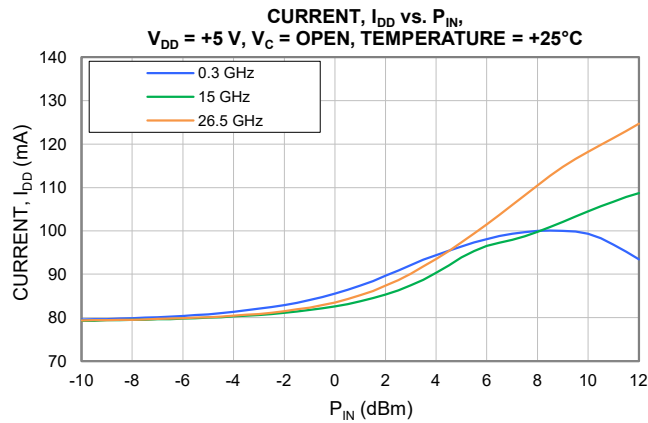
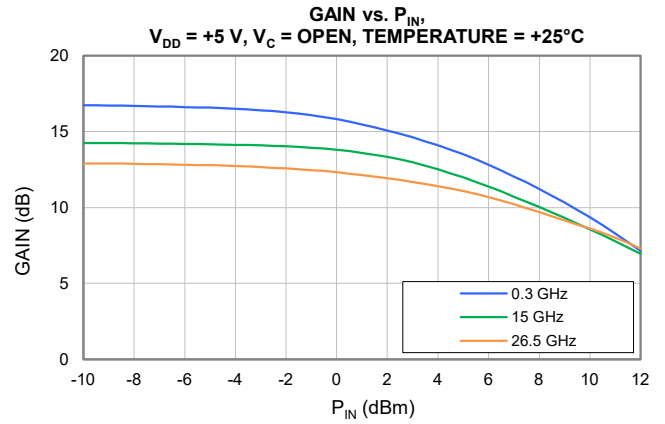
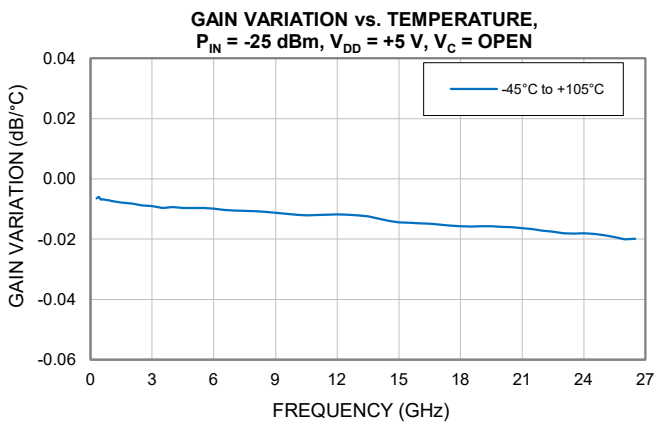
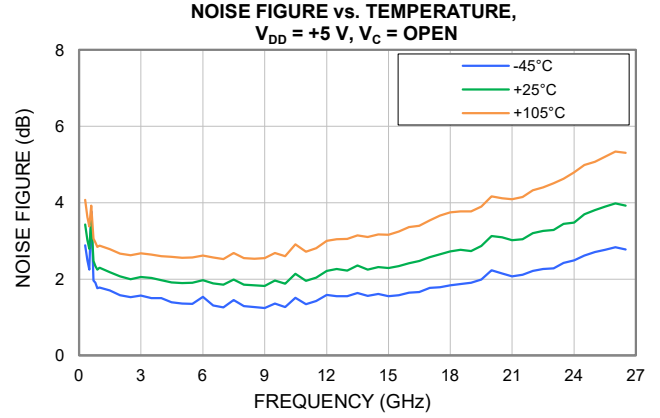
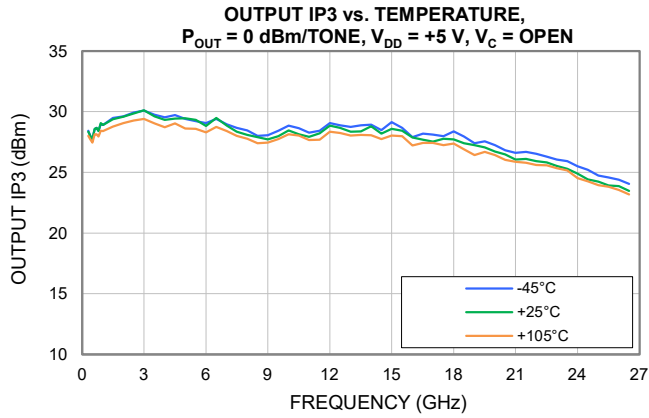

## Typical Performance Curves

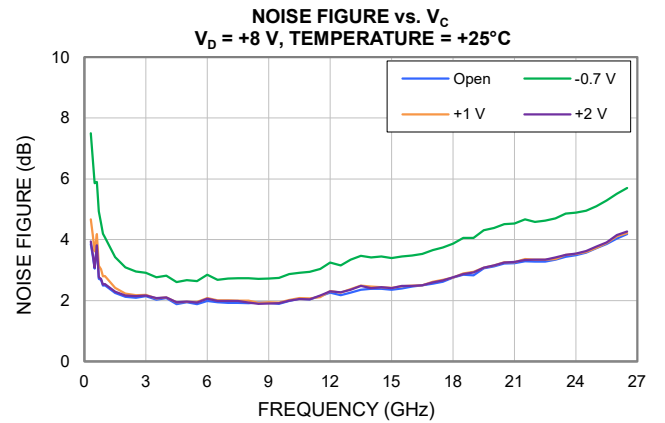
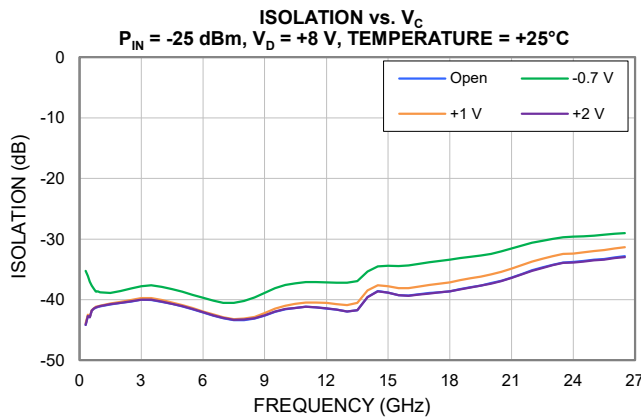
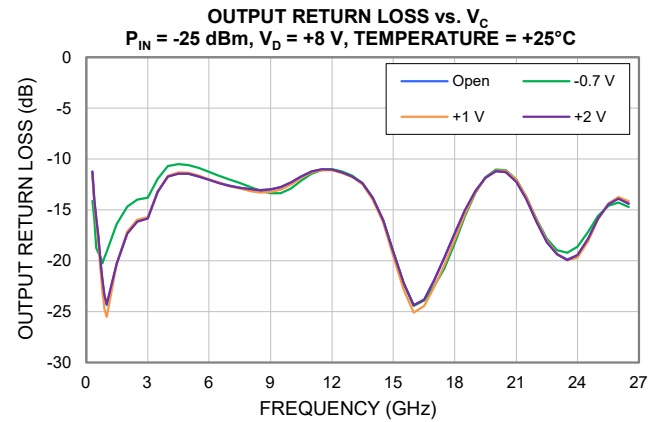
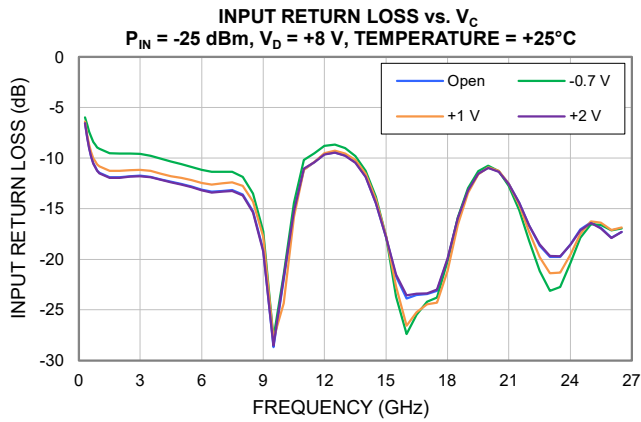
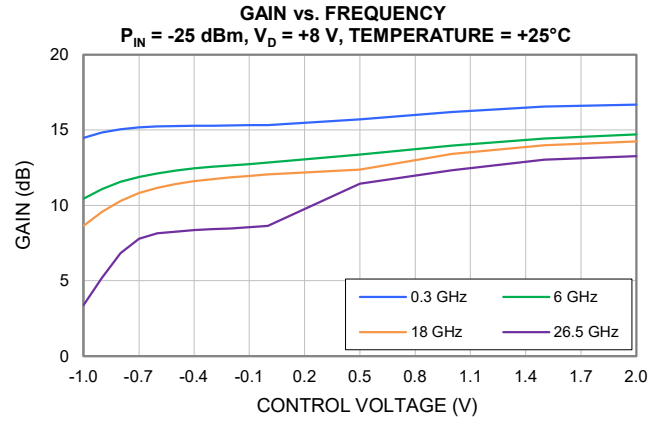
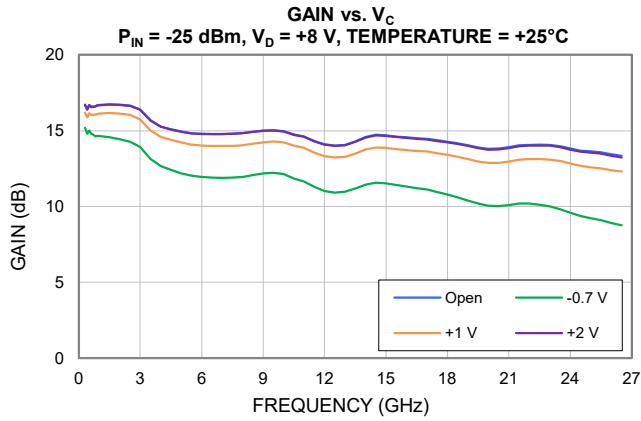

## Typical Performance Curves

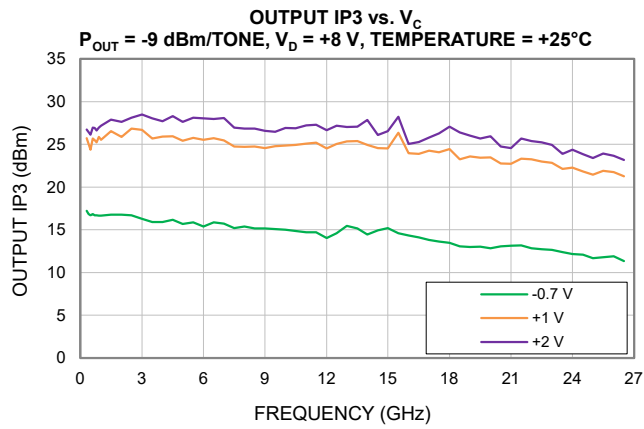
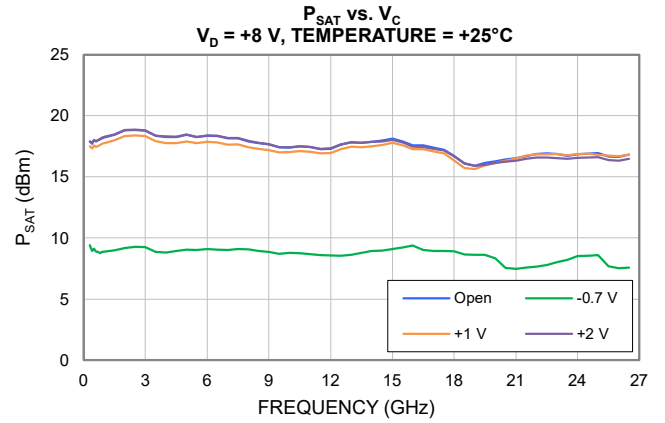
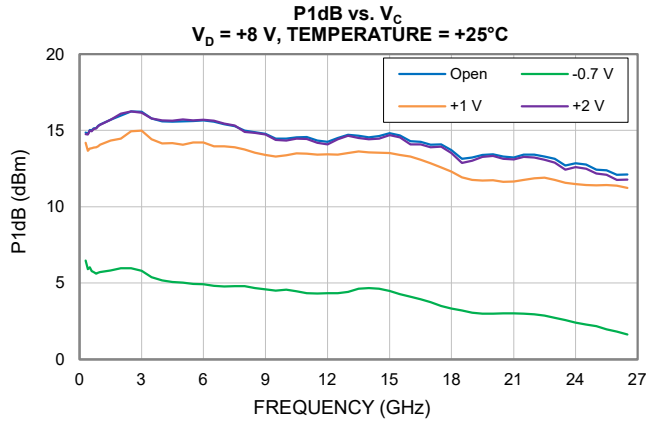

## Outline Dimensions

DG1677-4

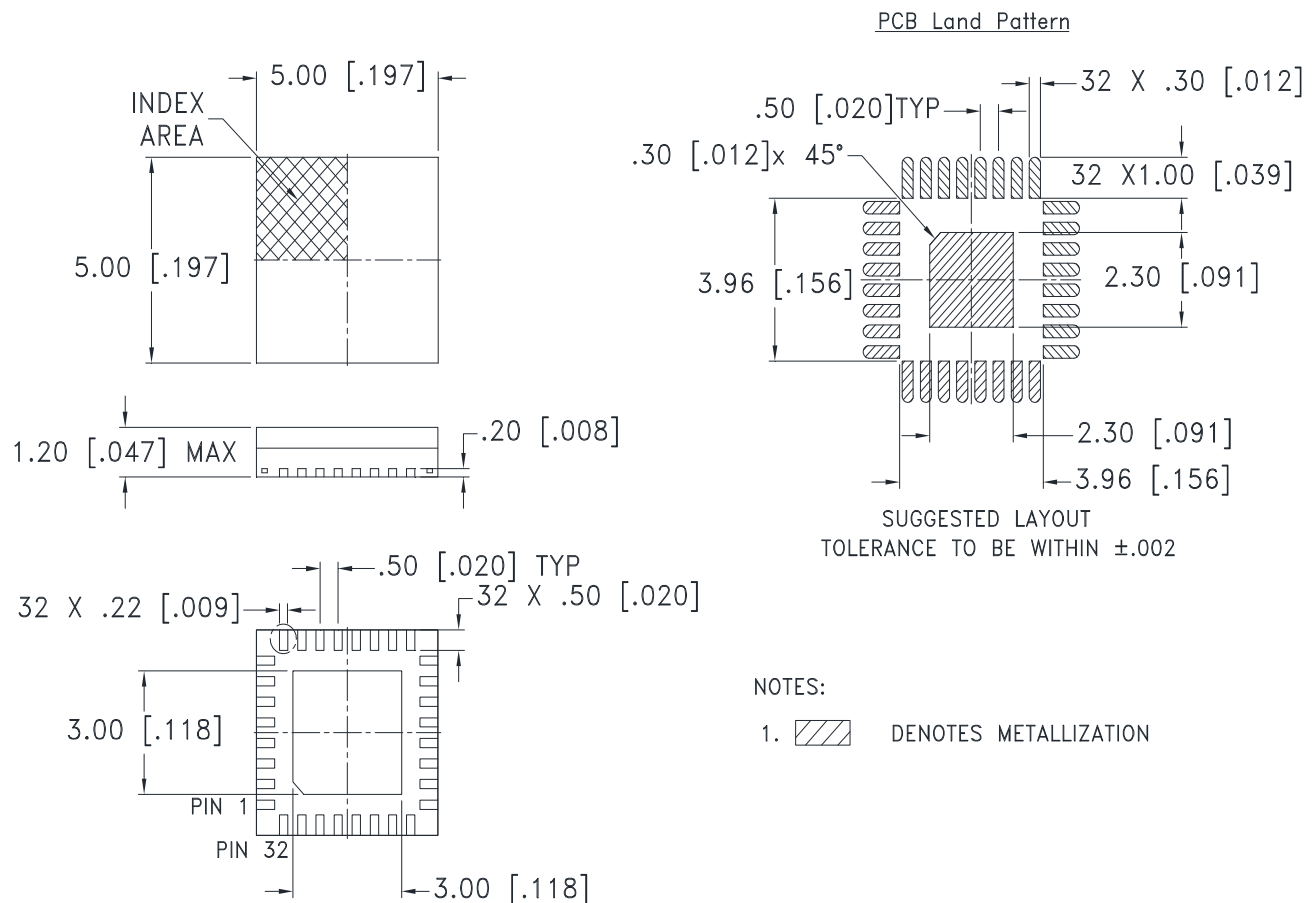

**Weight: 0.1 Grams**

**Dimensions are in mm(inches). Tolerances: 2 Pl.  $\pm .25(.01)$ ; 3 Pl.  $\pm .127(.005)$**

Notes:

1. Case material: Plastic.
2. Termination finish: PPF (NiPdAu Plating 0.5  $\mu\text{m}$ /0.02 $\mu\text{m}$ /0.05 $\mu\text{m}$ )



P.O. Box 350166, Brooklyn, New York 11235-0003 (718) 934-4500 Fax (718) 332-4661 For detailed performance specs & shopping online see Mini-Circuits web site



The Design Engineers Search Engine Provides ACTUAL Data Instantly From MINI-CIRCUITS At: [www.minicircuits.com](http://www.minicircuits.com)

RF/IF MICROWAVE COMPONENTS

THIRD ANGLE PROJECTION

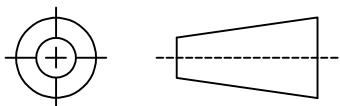

REVISIONS

REV	ECN No.	DESCRIPTION	DATE	DR	AUTH
OR	ECO-019836	NEW RELEASE	11/06/23	ITG	IL

**SUGGESTED MOUNTING CONFIGURATION  
FOR DG1677-4 CASE STYLE**

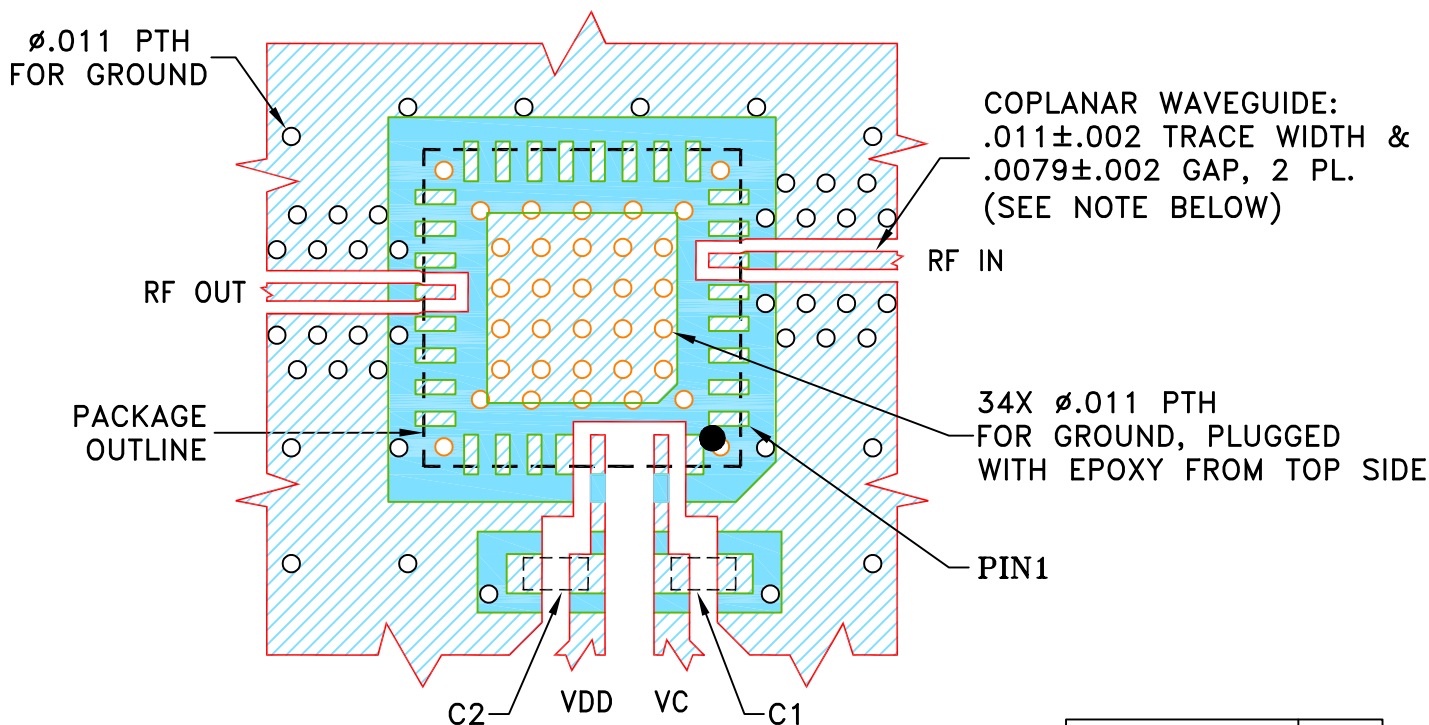

COPLANAR WAVEGUIDE:  
.011±.002 TRACE WIDTH &  
.0079±.002 GAP, 2 PL.  
(SEE NOTE BELOW)

COMPONENT	SIZE
C1, C2	0402

**NOTES:**

1. TRACE WIDTH AND GAP PARAMETERS ARE SHOWN FOR ROGERS RO4350B WITH DIELECTRIC THICKNESS .0066"±.0007". COPPER: 1/2 OZ. EACH SIDE. FOR OTHER MATERIALS TRACE WIDTH AND GAP MAY NEED TO BE MODIFIED.
2. CHIP COMPONENT FOOT PRINTS SHOWN FOR REFERENCE. FOR COMPONENT VALUES REFER TO TB-PVGA-273C+.
3. BOTTOM SIDE OF THE PCB IS CONTINUOUS GROUND PLANE.

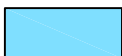

DENOTES PCB COPPER LAYOUT WITH SMOBC (SOLDER MASK OVER BARE COPPER).

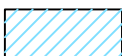

DENOTES COPPER LAND PATTERN FREE OF SOLDER MASK.

UNLESS OTHERWISE SPECIFIED

DIMENSIONS ARE IN INCHES  
TOLERANCES ON:  
2 PL DECIMALS ±  
3 PL DECIMALS ± .005  
ANGLES ±  
FRACTIONS ±

	INITIALS	DATE
DRAWN	ITG	11/06/23
CHECKED	GF	11/06/23
APPROVED	IL	11/06/23



**Mini-Circuits®**

13 Neptune Avenue  
Brooklyn NY 11235

**PL, DG1677-4, TB-PVGA-273C+**

Mini-Circuits®  
THIS DOCUMENT AND ITS CONTENTS ARE THE PROPERTY OF MINI-CIRCUITS. EXCEPT FOR USE EXPRESSLY GRANTED, IN WRITING, TO ITS VENDORS, VENDEE AND THE UNITED STATES GOVERNMENT, MINI-CIRCUITS RESERVES ALL PROPRIETARY DESIGN, USE, MANUFACTURING AND REPRODUCTION RIGHTS THERETO. THESE CONTENTS SHALL NOT BE USED, DUPLICATED OR DISCLOSED TO ANY OUTSIDE PARTY, IN WHOLE OR IN PART, WITHOUT WRITTEN PERMISSION OF MINI-CIRCUITS.

SIZE A	CODE IDENT 15542	DRAWING NO: 98-PL-769	REV: OR
FILE: 98PL769	SCALE: 8:1	SHEET: 1 OF 1	



# Evaluation Board and Circuit

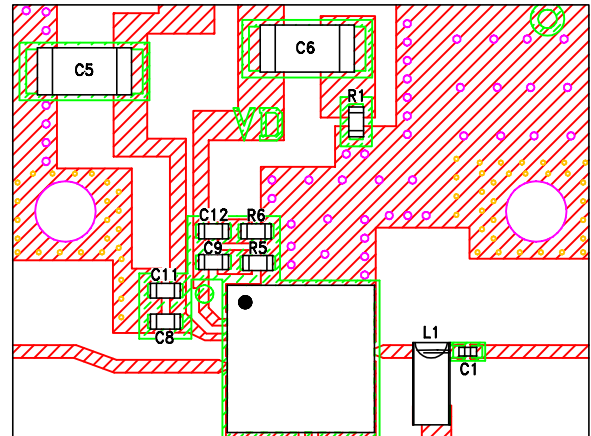
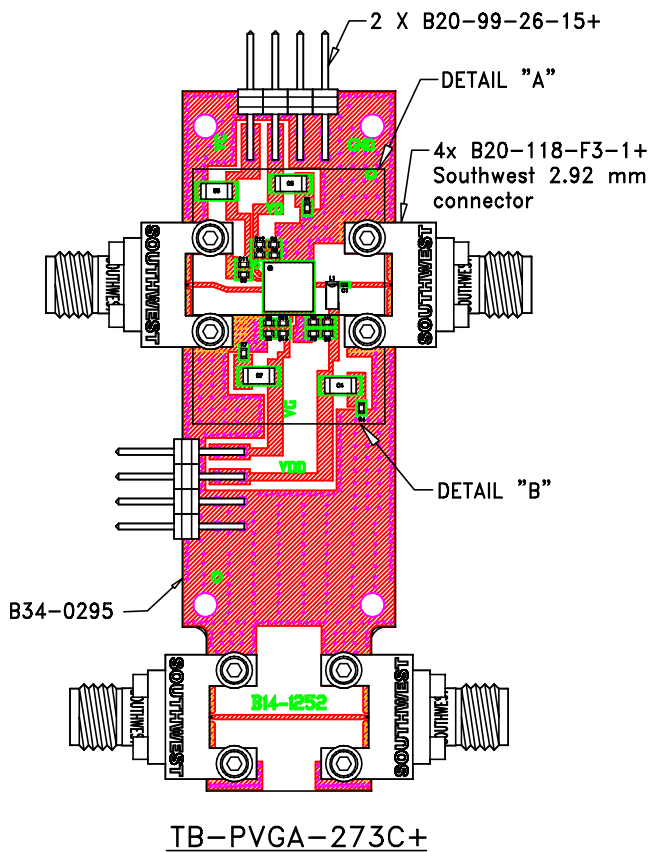

DETAIL "A"  
(SCALE 3:1)

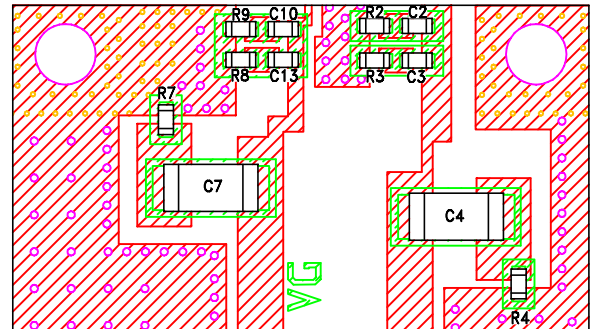

DETAIL "B"  
(SCALE 3:1)

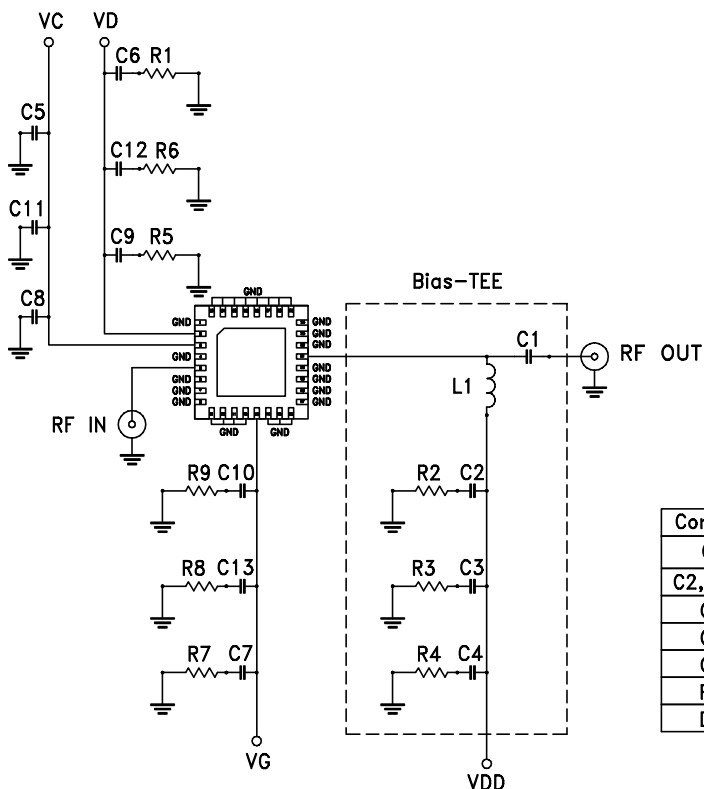

Schematic Diagram

Notes:

- 50 Ohm 2.92 mm Female end launch connectors.
- PCB Material: RO4003C or equivalent,  
Dielectric Constant=3.38±.05 Thickness=.008±.001

Function	Pad
RF-IN	5
RF-OUT	21
GND	1,4,6,7,8,9,10,11,12,14,15, 16,17,18,19,20,22,23,24,25, 26,27,28,29,30,31,32
VD	2
VC	3
VG	13

Components	Size	Value	Part Numbers	Manufacturer
C1	0201	30pF	P21BN300M5T	KNOWLES DIELECTRIC
C2,C8,C9,C10	0402	100pF	GRM1555C1H101JA01D	MURATA
C3	0402	.01uF	04023C103KAT2A	AVX CORPORATION
C4-C7	1206	4.7uF	12063C475KAT2A	AVX CORPORATION
C11-13	0402	.001uF	GRM1555C1H102JA01D	MURATA
R1-R9	0402	0Ω JUMPER	RK73Z1ETTP	KOA SPEER
DUT	5X5mm	-	PVGA-273+	-

Mini-Circuits®

All Mini-Circuits products are manufactured under exacting quality assurance and control standards, and are capable of meeting published specifications after being subjected to any or all of the following physical and environmental test.

Specification	Test/Inspection Condition	Reference/Spec
Operating Temperature	-45° to +85° C	Individual Model Data Sheet
Storage Temperature	-65° to 150°C	Individual Model Data Sheet
Moisture Sensitivity: Level 3	Bake at 125°C for 24 hours. Soak at 30°C/60%RH for 192 hours, Reflow 3 cycles at 260°C peak	J-STD-020D
Unbiased HAST	Temperature: 130°C, RH: 85%, Pressure: 33.3 psia Duration: 96 hours	JESD22-A118A, Test Condition A
Temperature Cycling	-65°C to +150°C, Dwell Time: 15 mins 500 cycles	JESD22-A104E, Condition C
HTSL	Temperature: 150°C Duration: 1000 hours	JESD22-A103E, Test Condition B
HTOL	1000 Hours at 125°C	JESD22-A108
ESD HBM	Refer datasheet for classification	JS-001
Vibration (Variable Frequency)	Sinusoidal vibration, 20 - 2000 Hz, 4 min sweeps, 16 min along each of 3 axis, amplitude limits of 20g and 0.06 in	MIL-STD-883, Method 2007, Condition A
Drop Test	1m drops onto concrete in final packed box in 6 orientations	--
Bend Test	1mm deflection for 5 seconds. Board thickness: 0.024", Span: 2.75"	--
Solderability	10x magnification	J-STD-002 Method B, B1



All Mini-Circuits products are manufactured under exacting quality assurance and control standards, and are capable of meeting published specifications after being subjected to any or all of the following physical and environmental test.

Specification	Test/Inspection Condition	Reference/Spec
Resistance to Soldering Heat	Sn-Pb Eutectic Process: 240°C peak Pb-Free Process: 260°C peak	J-STD-020