



MMIC DIE

Variable Gain Amplifier

PVGA-123-D+

Mini-Circuits

50Ω 0.4 to 12 GHz

THE BIG DEAL

- Wide Bandwidth 0.4 to 12 GHz
- High OIP3 Typ. +30 dBm
- Single Positive Supply +6V
- Adjustable Gain Range Typ. 16 dB

APPLICATIONS

- Radar, EW, and ECM Defense Systems
- 5G MIMO and Back Haul Radio Systems
- Test and Measurement Equipment

FUNCTIONAL DIAGRAM

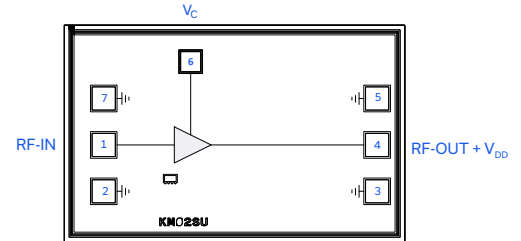

SEE ORDERING INFORMATION ON THE LAST PAGE

PRODUCT OVERVIEW

The PVGA-123-D+ is a GaAs pHEMT high performance variable gain amplifier operating from 0.4 to 12 GHz. The amplifier provides 16 dB Gain, +30 dBm OIP3 and +22 dBm P1dB with 17 dB typical return loss while operating from +6V and 77 mA DC power. The amplifier gain is voltage adjustable over a 16 dB dynamic range while maintaining excellent input IP3. The amplifier is ideal for use in very wideband ECM, Test and Measurement and Back Haul Radio systems

KEY FEATURES

Features	Advantages
Wideband: 0.4 to 12 GHz • 16 dB Typ. Gain at 6 GHz • 13 dB Typ. Gain at 12 GHz	Suitable for wide bandwidth defense and test and measurement application as well as narrow band performance driven applications
High P1dB & OIP3 • +22 dBm Typ. P1dB • +30 dBm Typ. OIP3	Suitable as a driver amplifier in receiver/transmitter chains
Adjustable Gain, 16 dB	Enables temperature compensation and power control for transmit and receive signal chains
Unpackaged Die	Enables integration into hybrid chip and wire assemblies

REV. OR
ECO-018346
PVGA-123-D+
MCL NY
230626



**MMIC DIE**

Variable Gain Amplifier

PVGA-123-D+

Mini-Circuits

50Ω 0.4 to 12 GHz

ELECTRICAL SPECIFICATIONS¹ AT 25°C, V_c = +5V, UNLESS NOTED OTHERWISE

Parameter	Condition (GHz)	V _{DD} = +6V			V _{DD} = +5V			Units
		Min.	Typ.	Max.	Min.	Typ.	Max.	
Frequency Range		0.4		12	0.4		12	GHz
Gain	0.4		16.8			16.6		dB
	4		16.7			16.4		
	6		16.1			15.8		
	8		15.2			14.9		
	12		13.1			12.9		
Output Power at 1 dB Compression (P1dB)	0.4		+21.0			+19.3		dBm
	4		+20.7			+18.8		
	6		+19.8			+18.0		
	8		+19.4			+17.9		
	12		+19.1			+17.2		
Output Power at 3 dB Compression (P3dB) ²	0.4		+22.0			+20.1		dBm
	4		+21.7			+19.9		
	6		+21.1			+19.0		
	8		+20.9			+18.8		
	12		+19.9			+18.3		
Output Third-Order Intercept (P _{OUT} = -5 dBm/Tone)	0.4		+27			+27		dBm
	4		+33			+33		
	6		+30			+29		
	8		+29			+28		
	12		+30			+27		
Input Return Loss	0.4		18			19		dB
	4		14			14		
	6		13			14		
	8		11			11		
	12		9			9		
Output Return Loss	0.4		18			19		dB
	4		14			14		
	6		12			12		
	8		12			12		
	12		15			15		
Isolation	0.4		26			26		dB
	4		27			27		
	6		29			29		
	8		30			29		
	12		29			29		
Noise Figure	0.4		5.4			5.5		dB
	4		4.4			4.4		
	6		4.5			4.5		
	8		4.5			4.5		
	12		4.7			4.7		
Device Operating (V _{DD})			+6			+5		V
Device Operating Current (I _{DD}) ³			77			72		mA
DC Current Variation vs. Temperature ⁴			26.9			42.5		μA/°C
DC Current Variation vs. Voltage ⁵			0.005					mA/mV

1. Electrical specifications are measured by soldering the die on Mini-Circuits Die Characterization Test Board. Board loss is de-embedded to the device.

2. Defined as Output Power in which gain is compressed 3dB.

3. Current at P_{IN} = -25 dBm.

4. ((Current at +85°C - Current at -45°C)/(+130°C).

5. ((Current at +6V in mA) - (Current at +5V mA))/((+6V - +5V)*1000)





MMIC DIE

Variable Gain Amplifier

PVGA-123-D+

Mini-Circuits

50Ω 0.4 to 12 GHz

ELECTRICAL SPECIFICATIONS⁶ OVER VARIOUS V_C AT 25°C, $V_{DD} = +6V$, UNLESS NOTED OTHERWISE

Parameter	Frequency (GHz)	Control Voltage, V_C						Units
		+0.8V	+1V	+2V	+3V	+4V	+5V	
DC Current, Typ.	-	8	14	30	43	59	77	mA
Gain, Typ.	0.4	6.9	8.4	11.2	14.6	16.1	16.8	dB
	4	5.7	7.8	11.1	14.5	16.0	16.7	
	6	2.7	5.6	9.6	13.5	15.2	16.1	
	8	0.1	3.5	8.2	12.4	14.3	15.2	
	12	-2.7	1.2	6.5	10.7	12.3	13.1	
Isolation, Typ.	0.4	19	19	21	23	25	26	dB
	4	20	20	22	25	26	27	
	6	23	22	24	26	28	29	
	8	25	24	25	27	29	30	
	12	26	25	25	27	29	29	
Input Return Loss, Typ.	0.4	8	10	16	28	21	18	dB
	4	13	16	27	20	16	14	
	6	10	12	15	15	14	13	
	8	9	9	10	11	11	11	
	9	8	8	8	9	9	9	
Output Return Loss, Typ.	0.4	6	6	10	21	26	18	dB
	4	7	9	12	18	16	14	
	6	5	6	8	11	12	12	
	8	4	5	6	9	11	12	
	12	5	6	8	12	14	15	
Output Power at 1 dB Compression (P1dB), Typ.	0.4	+21.7	+21.8	+22.1	+21.8	+21.2	+21.0	dBm
	4	+21.6	+21.7	+21.6	+21.3	+21.0	+20.7	
	6	+21.0	+21.1	+20.9	+20.5	+20.1	+19.8	
	8	+20.6	+20.8	+21.0	+20.5	+19.8	+19.4	
	12	+20.8	+21.3	+21.3	+19.3	+19.1	+19.1	
Output Power at 3 dB Compression (P3dB) ⁷ , Typ.	0.4	+21.7	+21.7	+22.1	+22.3	+22.3	+22.0	dBm
	4	+21.6	+21.6	+21.8	+21.8	+21.8	+21.7	
	6	+20.9	+21.0	+21.3	+21.2	+21.2	+21.1	
	8	+20.5	+20.7	+21.1	+21.2	+21.0	+20.9	
	12	+20.8	+21.0	+21.4	+19.9	+19.9	+19.9	
Output Third-Order Intercept, Typ. ($P_{OUT} = -5$ dBm/Tone)	0.4	+11	+12	+12	+20	+25	+27	dBm
	4	+12	+14	+14	+25	+31	+33	
	6	+10	+16	+13	+24	+28	+30	
	8	+9	+16	+12	+23	+27	+29	
	12	+8	+12	+13	+22	+26	+30	
Noise Figure, Typ.	0.4	8.6	8.7	7.2	6.0	5.6	5.4	dB
	4	5.6	5.3	5.0	4.5	4.4	4.4	
	6	6.0	5.4	5.0	4.5	4.5	4.5	
	8	6.8	5.7	5.1	4.5	4.5	4.5	
	12	8.6	7.0	5.4	4.8	4.6	4.7	

6. Electrical specifications are measured by soldering the die on Mini-Circuits Die Characterization Test Board. Board loss is de-embedded to the device.

7. Defined as Output Power at which gain is compressed by 3dB.



MMIC DIE

Variable Gain Amplifier

PVGA-123-D+

Mini-Circuits

50Ω 0.4 to 12 GHz

ELECTRICAL SPECIFICATIONS⁸ OVER VARIOUS V_C AT 25°C, $V_{DD} = +5V$, UNLESS NOTED OTHERWISE

Parameter	Frequency (GHz)	Control Voltage, V_C						Units
		+0.8V	+1V	+2V	+3V	+4V	+5V	
DC Current, Typ.	-	7	13	29	41	55	72	mA
Gain, Typ.	0.4	6.5	8.3	10.7	14.1	15.8	16.6	dB
	4	5.1	7.7	10.5	13.9	15.6	16.4	
	6	2.0	5.4	8.9	12.8	14.8	15.8	
	8	-0.7	3.3	7.5	11.8	13.9	14.9	
	12	-3.6	0.9	5.8	10.1	12.0	12.9	
Isolation, Typ.	0.4	19	19	21	23	25	26	dB
	4	20	20	22	24	26	27	
	6	23	22	24	26	28	29	
	8	25	24	25	27	28	29	
	12	26	25	25	27	28	29	
Input Return Loss, Typ.	0.4	8	10	16	27	23	19	dB
	4	13	16	25	22	16	14	
	6	10	12	15	16	14	14	
	8	9	9	10	11	11	11	
	12	9	8	8	8	9	9	
Output Return Loss, Typ.	0.4	5	6	9	18	31	19	dB
	4	7	9	11	17	16	14	
	6	5	6	7	10	12	12	
	8	4	5	6	9	11	12	
	12	5	6	8	11	14	15	
Output Power at 1 dB Compression (P1dB), Typ.	0.4	+19.3	+19.6	+20.0	+19.8	+19.0	+19.3	dBm
	4	+19.5	+19.7	+19.8	+19.3	+18.7	+18.8	
	6	+19.1	+19.3	+18.6	+18.3	+17.9	+18.0	
	8	+19.1	+19.2	+19.1	+18.4	+17.6	+17.9	
	12	+19.8	+20.1	+19.6	+17.5	+17.2	+17.2	
Output Power at 3 dB Compression (P3dB) ⁹ , Typ.	0.4	+19.3	+19.4	+20.0	+20.3	+20.3	+20.1	dBm
	4	+19.5	+19.5	+19.9	+20.1	+20.1	+19.9	
	6	+19.1	+19.1	+19.5	+19.3	+19.1	+19.0	
	8	+19.0	+19.1	+19.4	+19.4	+19.1	+18.9	
	12	+19.8	+20.0	+18.2	+18.1	+18.1	+18.3	
Output Third-Order Intercept, Typ. ($P_{OUT} = -5$ dBm/Tone)	0.4	+11	+13	+11	+18	+24	+27	dBm
	4	+11	+14	+13	+22	+32	+33	
	6	+9	+16	+12	+22	+28	+29	
	8	+8	+18	+11	+21	+26	+28	
	12	+8	+13	+12	+20	+25	+27	
Noise Figure, Typ.	0.4	8.8	8.8	7.4	6.1	5.7	5.5	dB
	4	5.7	5.3	5.1	4.5	4.4	4.4	
	6	6.2	5.4	5.1	4.6	4.5	4.5	
	8	7.1	5.8	5.2	4.6	4.5	4.5	
	12	9.4	7.0	5.5	4.9	4.8	4.7	

8. Electrical specifications are measured by soldering the die on Mini-Circuits Die Characterization Test Board. Board loss is de-embedded to the device.

9. Defined as Output Power at which gain is compressed 3dB.



TYPICAL PERFORMANCE GRAPHS

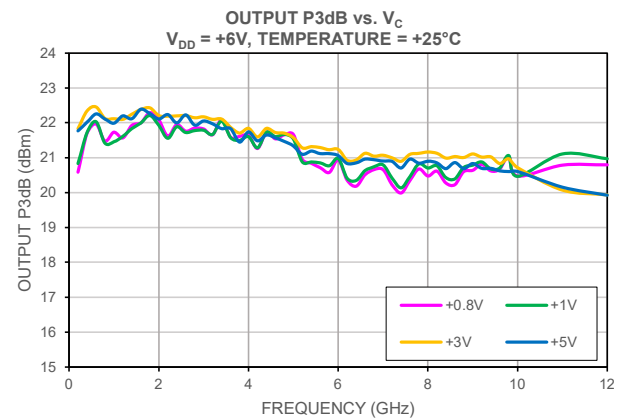
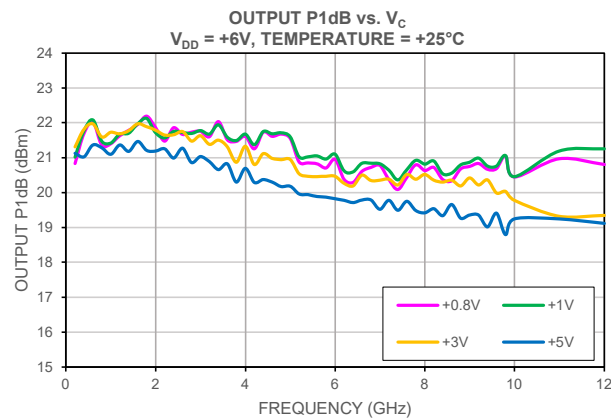
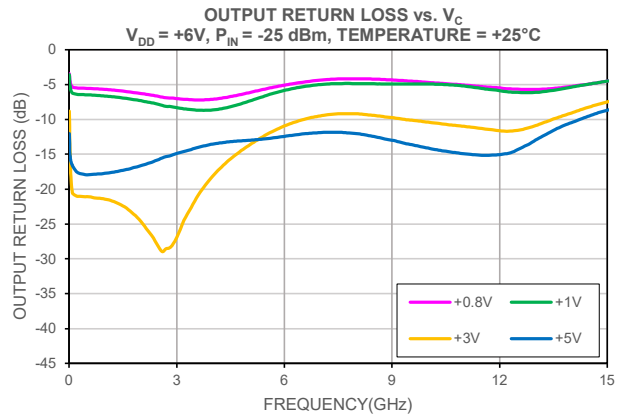
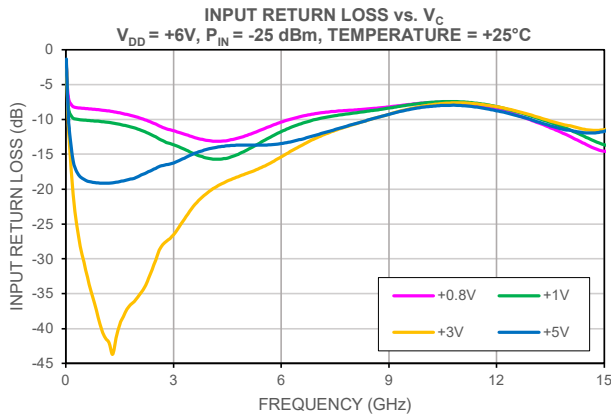
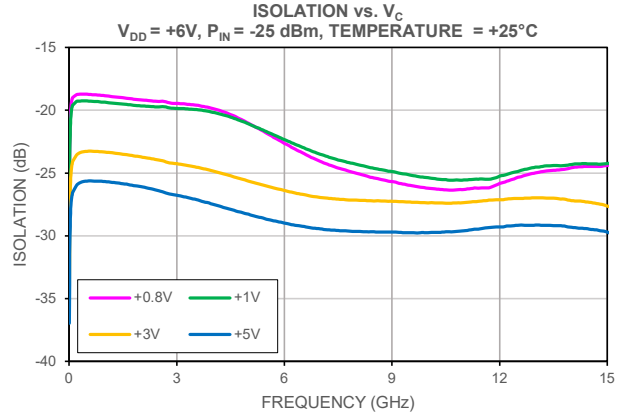
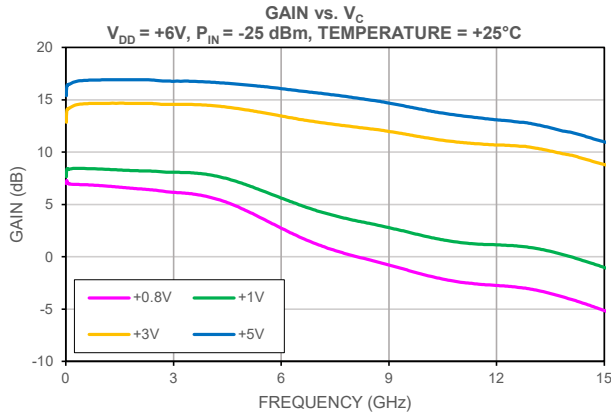



MMIC DIE

Variable Gain Amplifier

PVGA-123-D+

Mini-Circuits

50Ω 0.4 to 12 GHz

TYPICAL PERFORMANCE GRAPHS

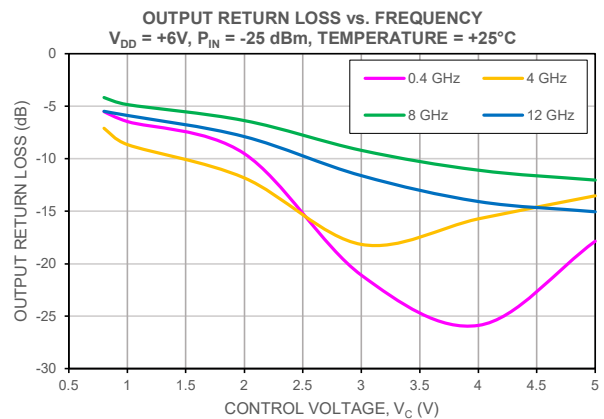
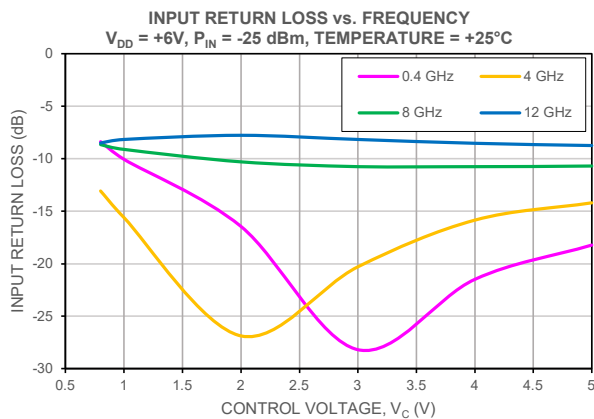
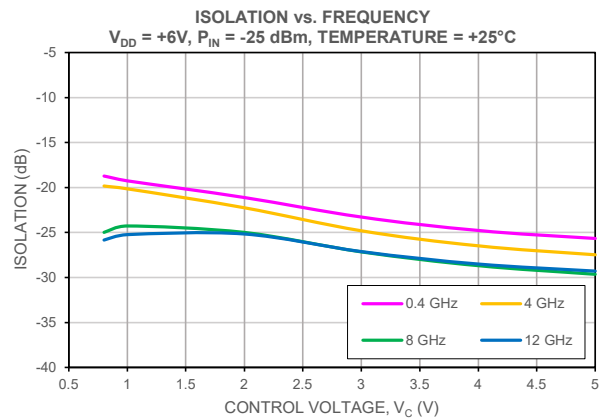
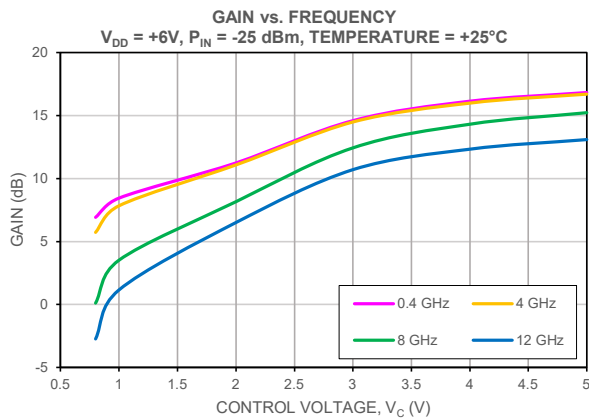
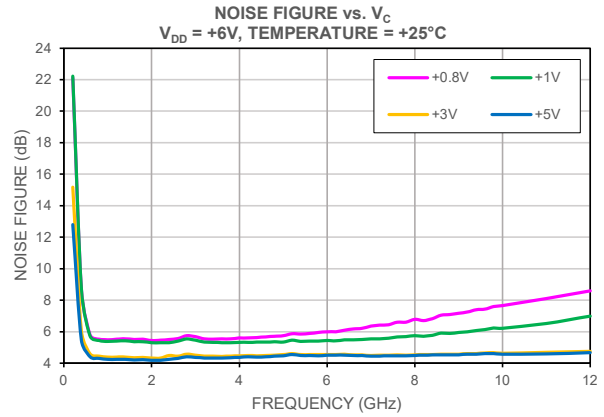
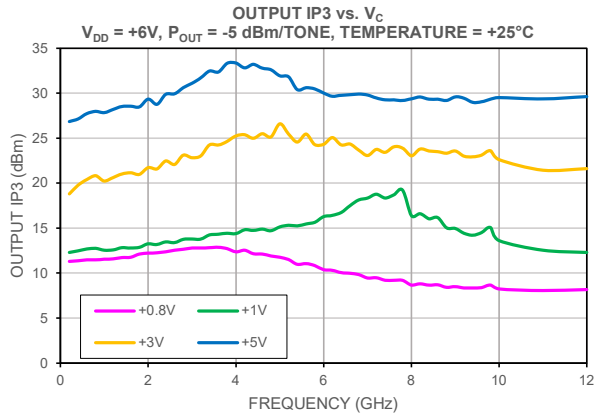



TYPICAL PERFORMANCE GRAPHS

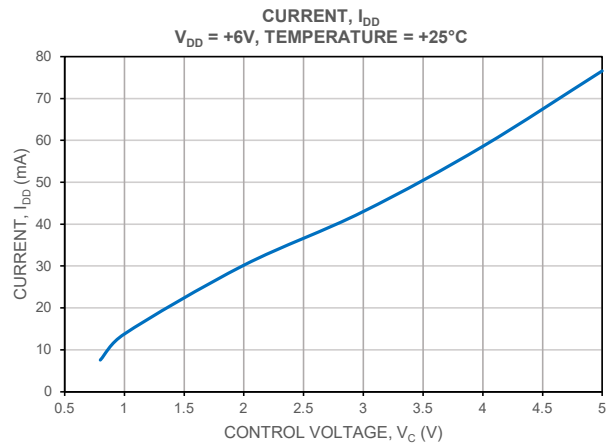
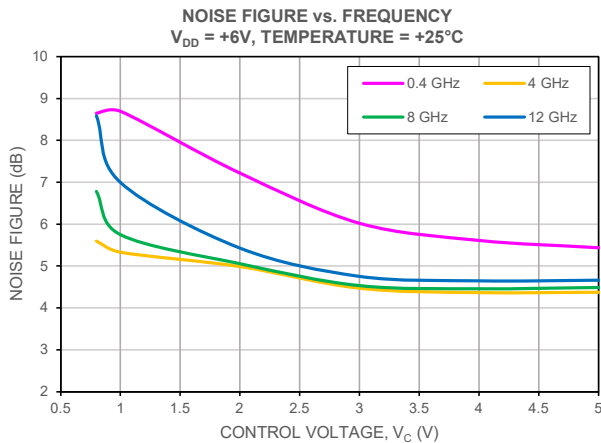
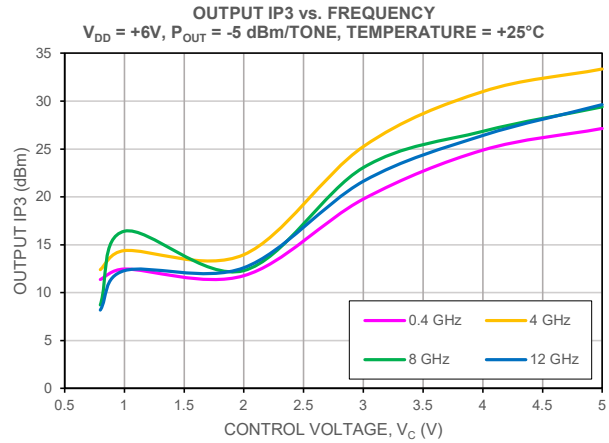
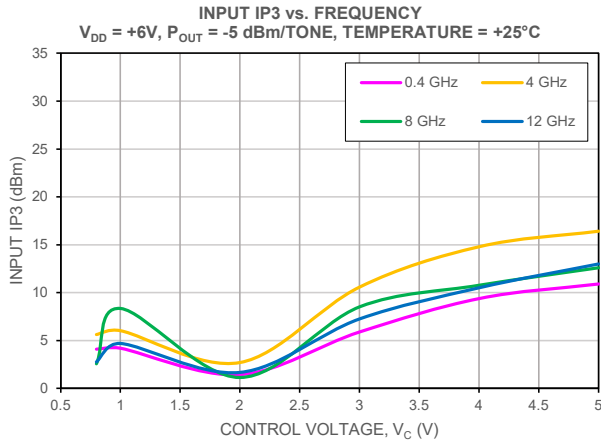
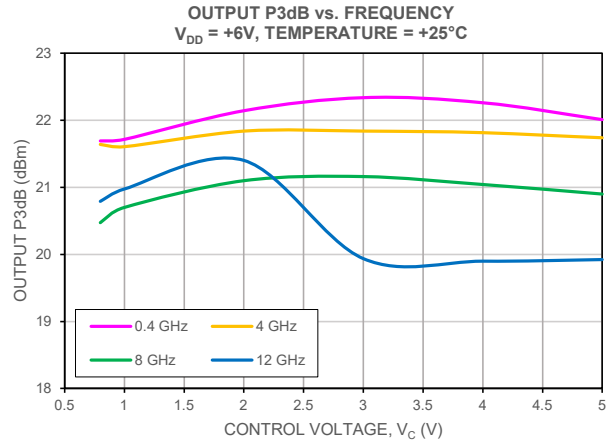
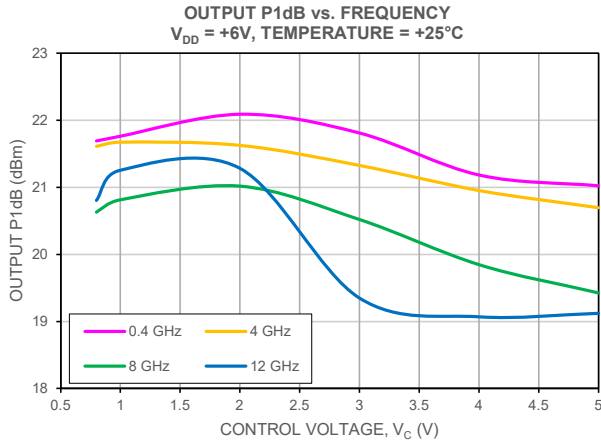



TYPICAL PERFORMANCE GRAPHS

Note: All data on this page represents the Die attached in a 3x3mm 12-Lead QFN style package and measured on Mini-Circuits Characterization Test Board TB-PVGA-123C+.

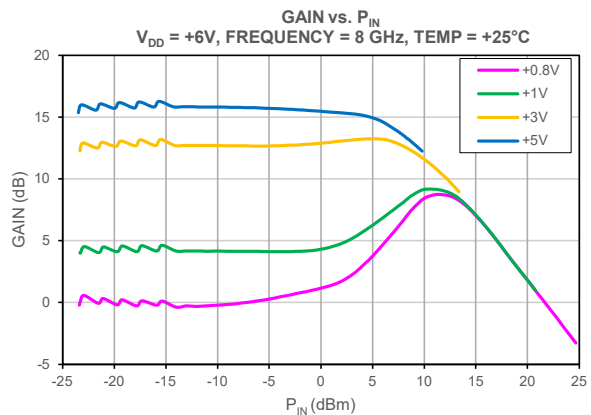
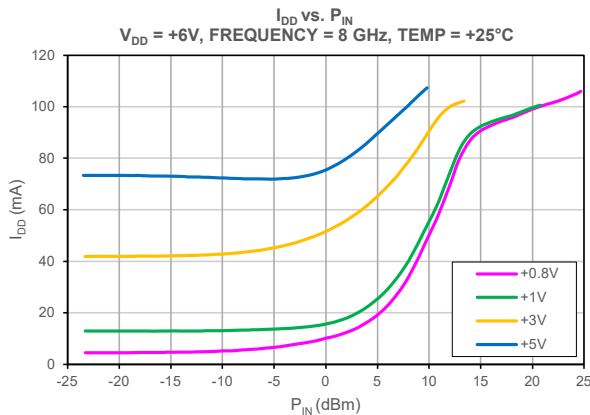
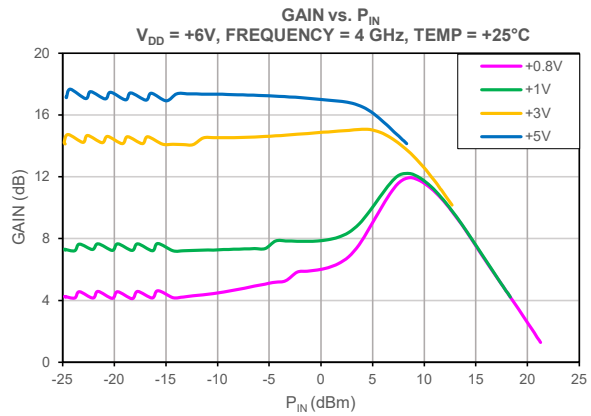
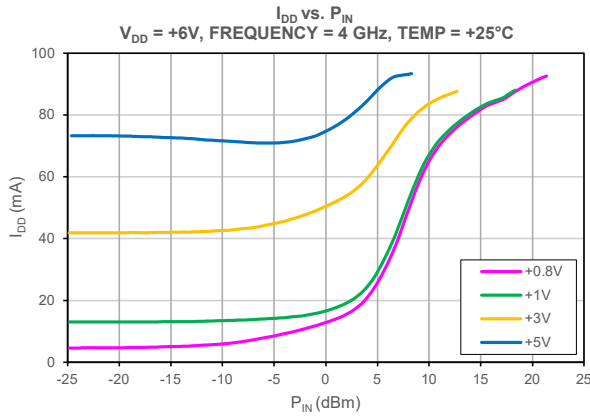
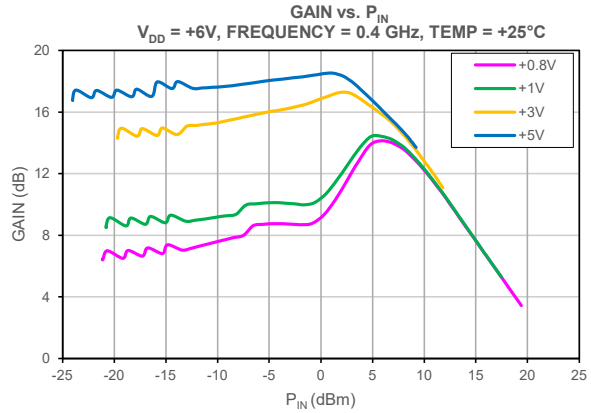
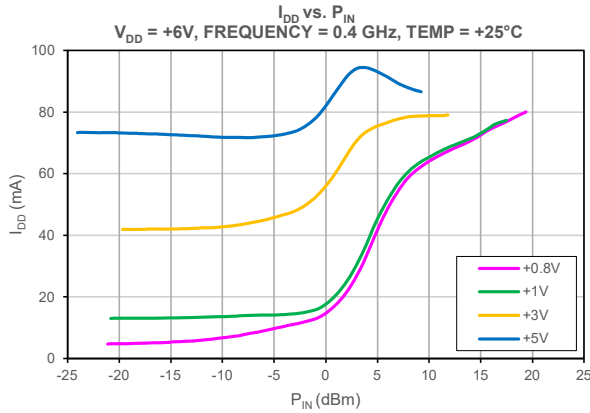



MMIC DIE

Variable Gain Amplifier **PVGA-123-D+**

Mini-Circuits

50Ω 0.4 to 12 GHz

TYPICAL PERFORMANCE GRAPHS

Note: All data on this page represents the Die attached in a 3x3mm 12-Lead QFN style package and measured on Mini-Circuits Characterization Test Board TB-PVGA-123C+.

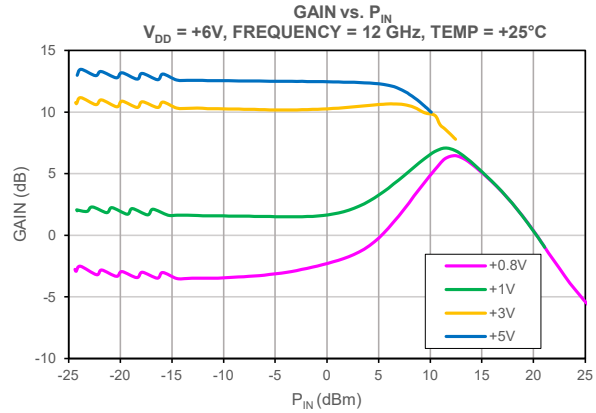
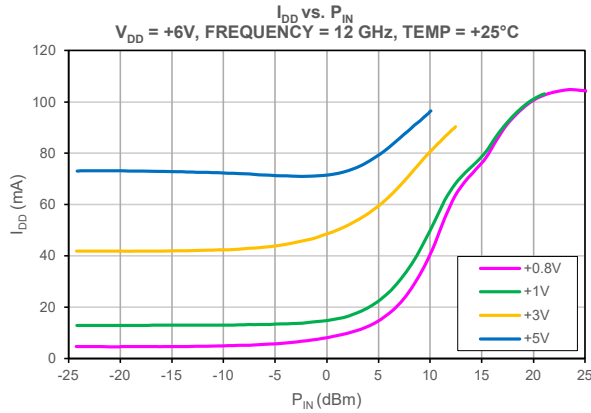



TYPICAL PERFORMANCE GRAPHS

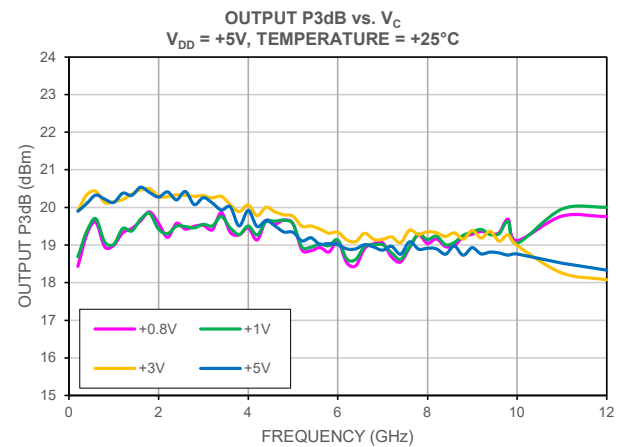
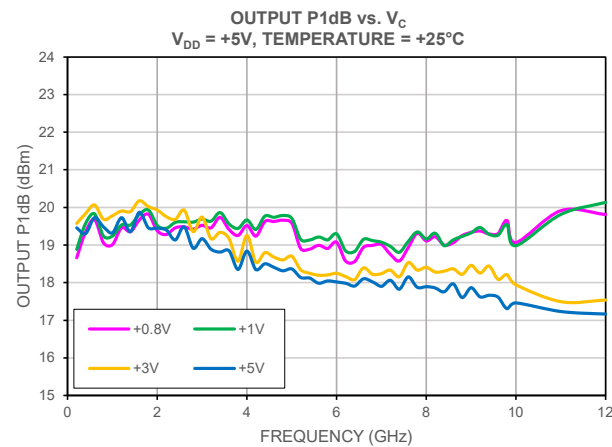
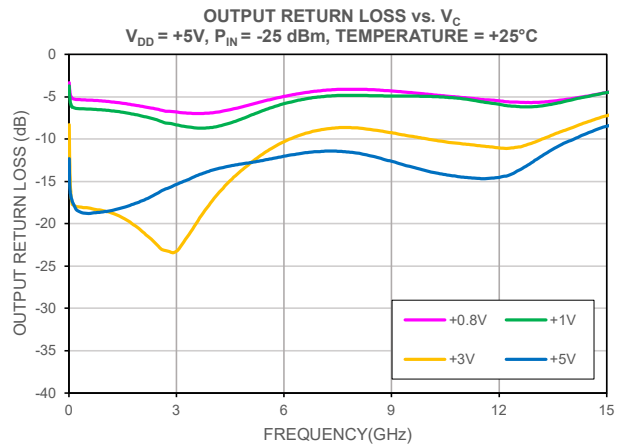
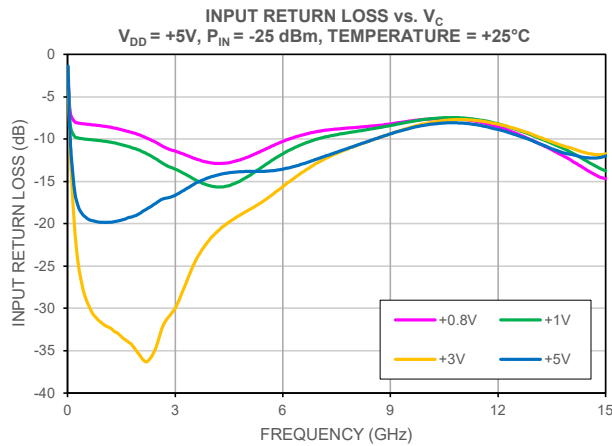
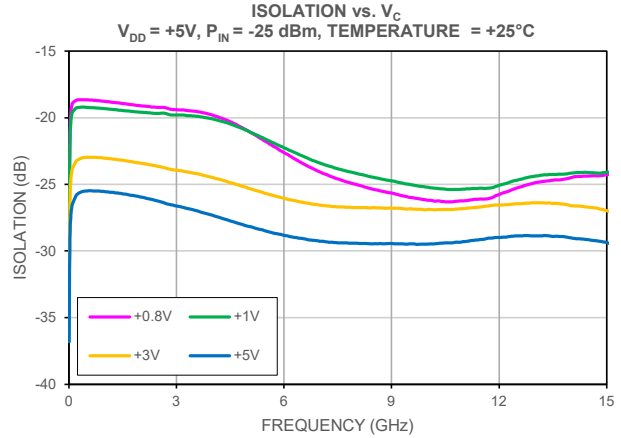
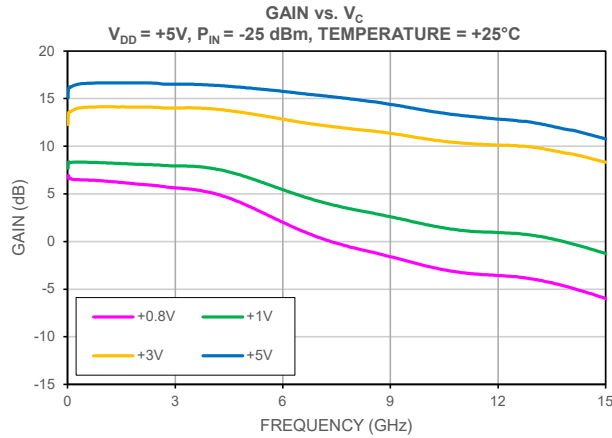



MMIC DIE

Variable Gain Amplifier

PVGA-123-D+

Mini-Circuits

50Ω 0.4 to 12 GHz

TYPICAL PERFORMANCE GRAPHS

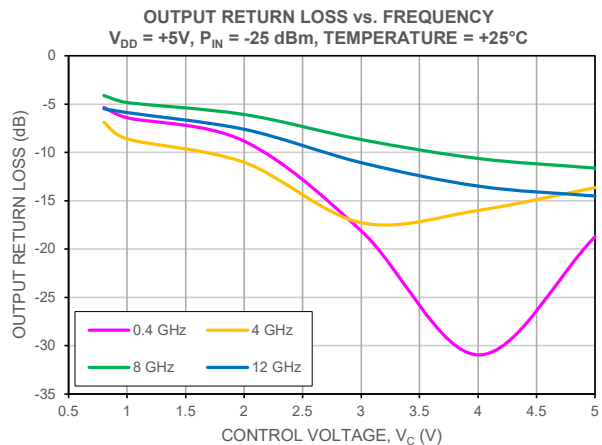
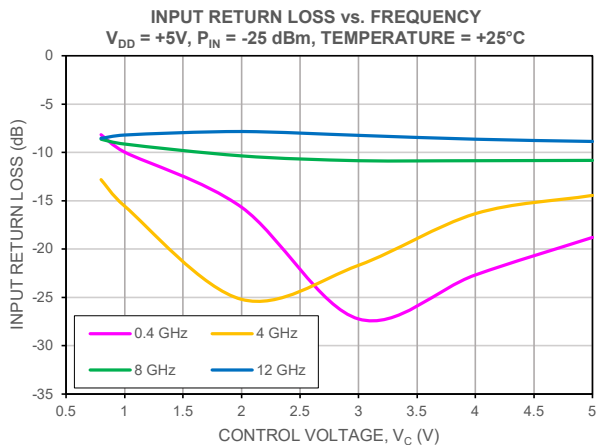
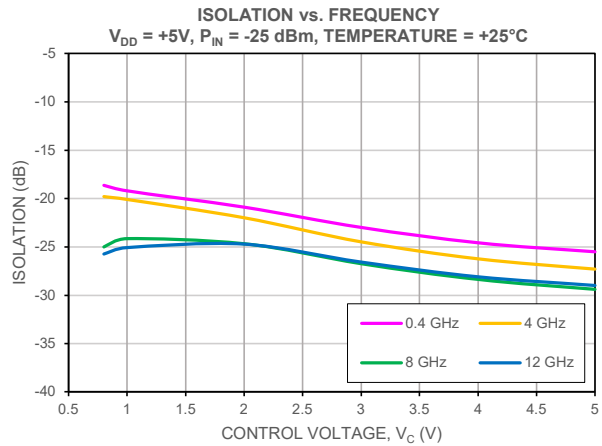
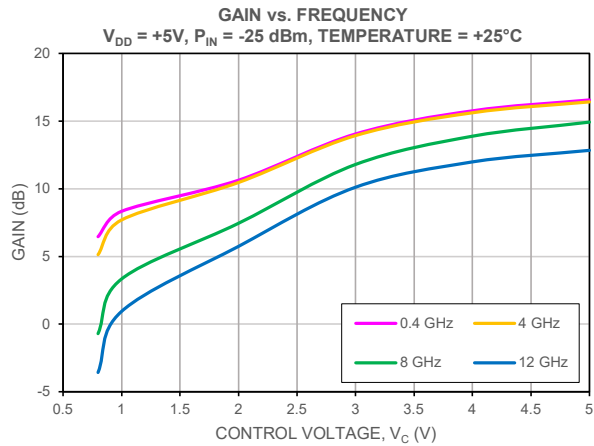
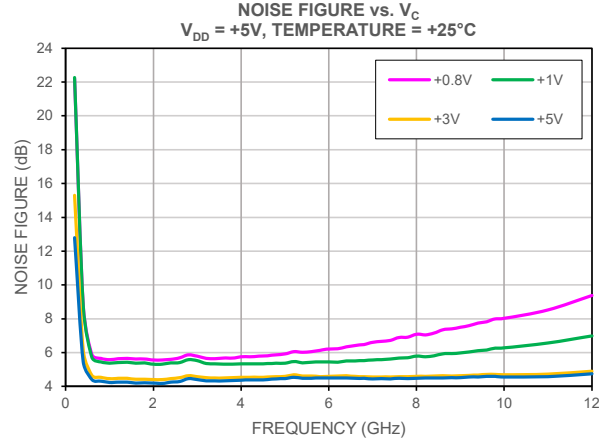
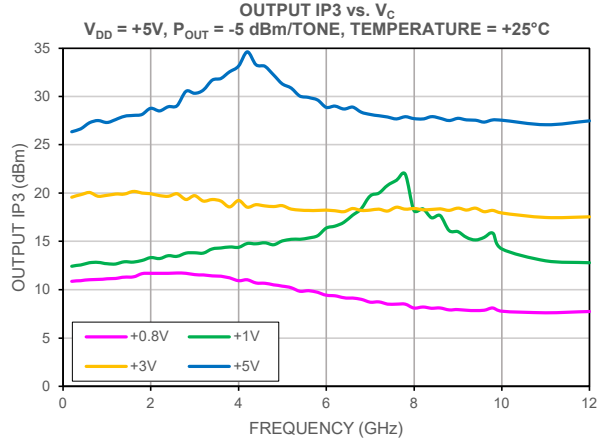



TYPICAL PERFORMANCE GRAPHS

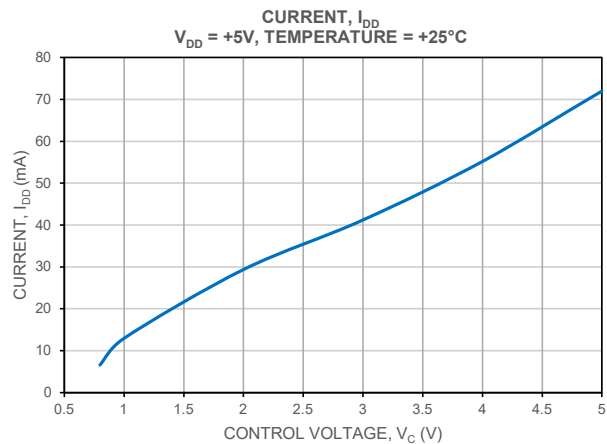
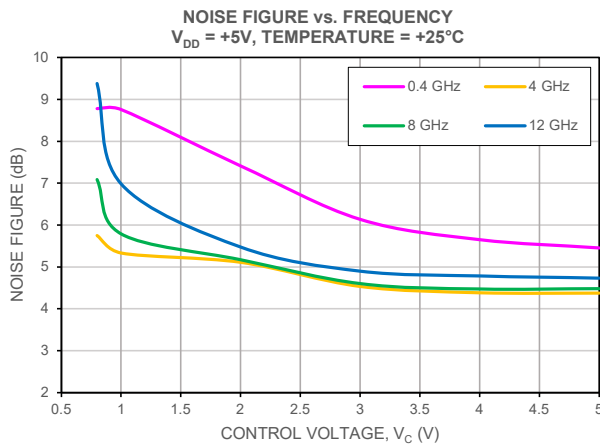
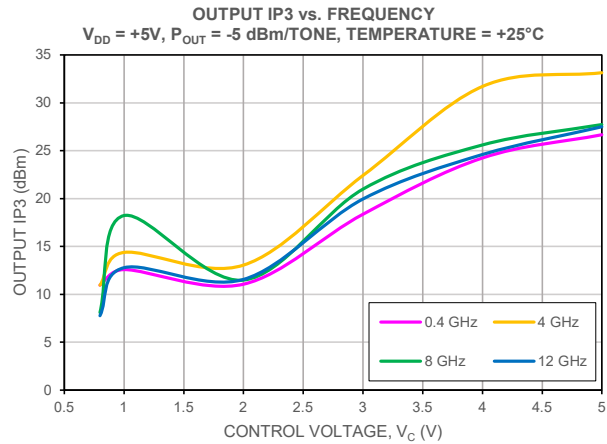
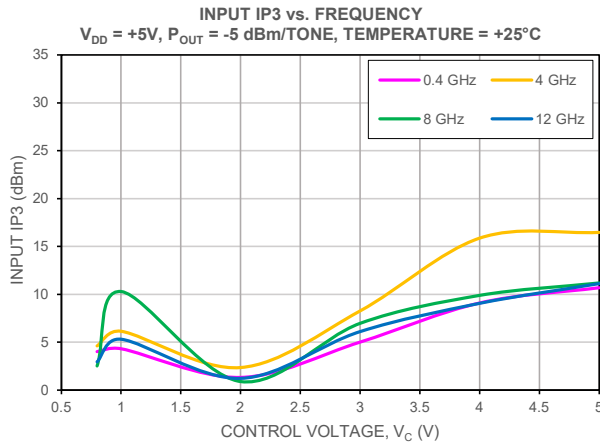
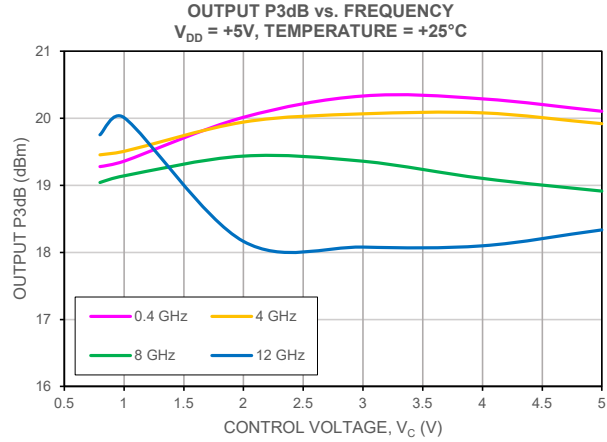
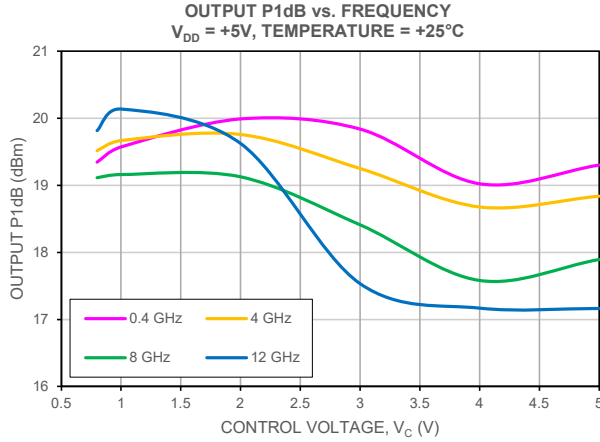



TYPICAL PERFORMANCE GRAPHS

Note: All data on this page represents the Die attached in a 3x3mm 12-Lead QFN style package and measured on Mini-Circuits Characterization Test Board TB-PVGA-123C+.

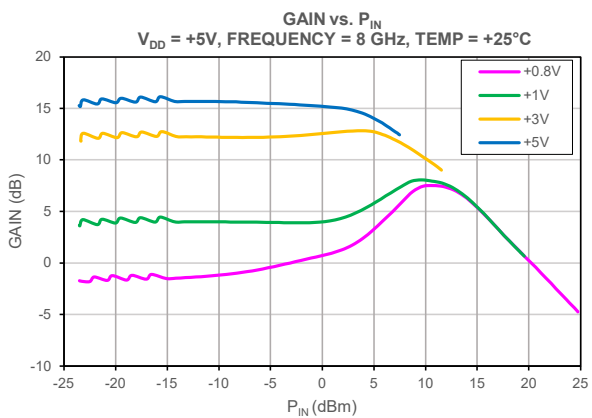
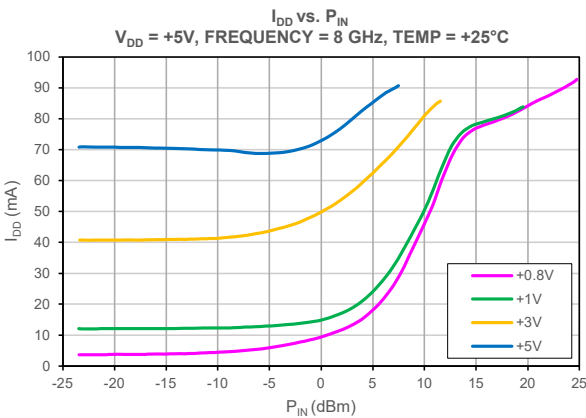
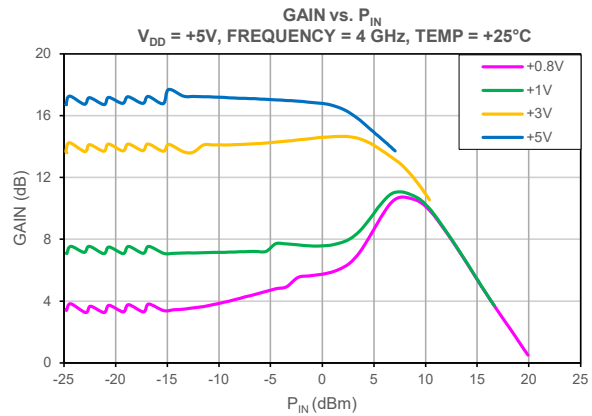
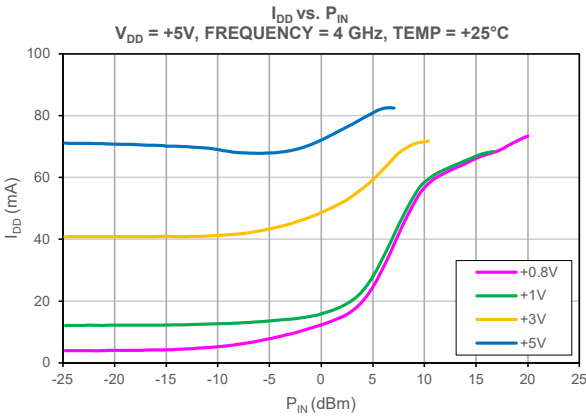
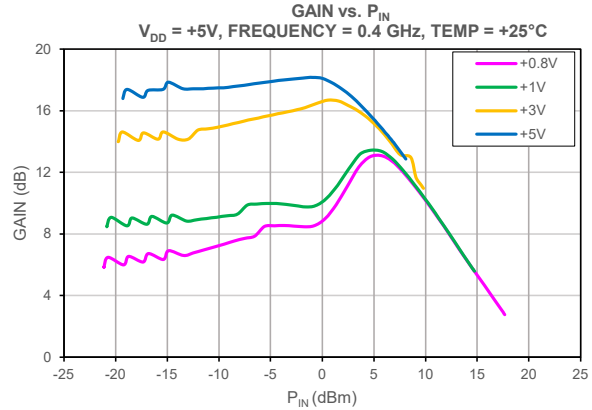
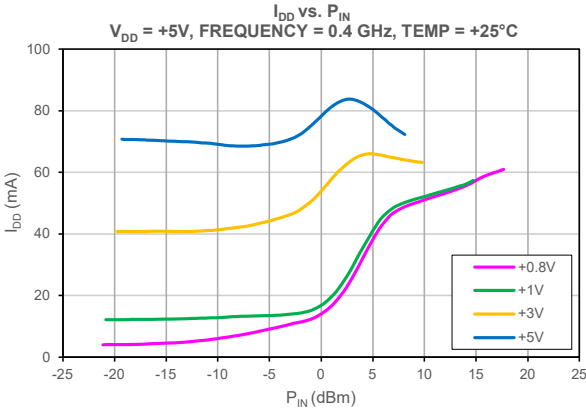



MMIC DIE

Variable Gain Amplifier **PVGA-123-D+**

Mini-Circuits

50Ω 0.4 to 12 GHz

TYPICAL PERFORMANCE GRAPHS

Note: All data on this page represents the Die attached in a 3x3mm 12-Lead QFN style package and measured on Mini-Circuits Characterization Test Board TB-PVGA-123C+.

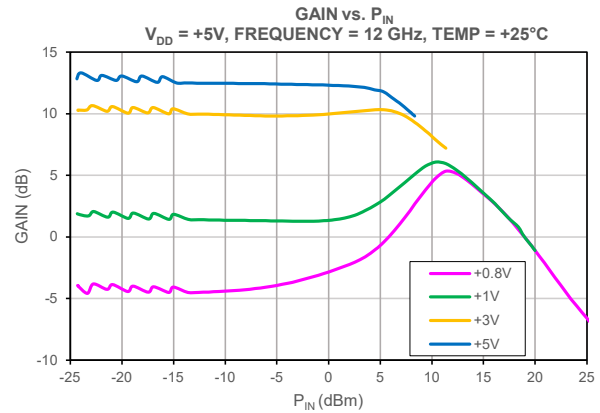
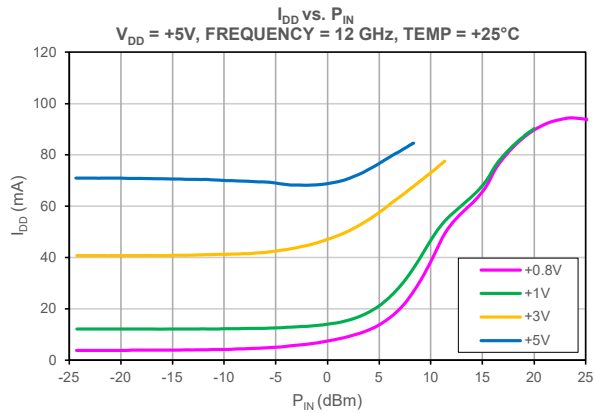



ABSOLUTE MAXIMUM RATINGS¹⁰

Parameter	Ratings
Operating Temperature	-45°C to +85°C
Storage Temperature ¹¹	+20°C to +35°C
Junction Temperature ¹²	+175°C
Total Power Dissipation	1.5 W
RF Input Power (CW), $V_{DD} = +6V$, $V_C = +5V$	+23 dBm
DC Voltage at V_{DD} Pad	+10.5V
DC Voltage at V_C Pad	+10.5V

- 10. Permanent damage may occur if these limits are exceeded.
- 11. For die shipped in Gel-Pak see ENV-80 (limited by packaging).
- 12. Peak temperature on top of Die.

THERMAL RESISTANCE

Parameter	Ratings
Thermal Resistance (Θ_{jc}) ¹³	53.2 °C/W

- 13. Θ_{jc} = (Hot Spot Temperature on Die - Temperature at Ground Lead)/Dissipated Power

ESD RATING¹⁴

	Class	Voltage Range	Reference Standard
HBM	1A	250 to <500V	ANSI/ESDA/JEDEC JS-001-2017
CDM	C3	250 to <500V	JESD22-C101F



ESD HANDLING PRECAUTION: This device is designed to be Class 1A for HBM. Static charges may easily produce potentials higher than this with improper handling and can discharge into DUT and damage it. As a preventive measure Industry standard ESD handling precautions should be used at all times to protect the device from ESD damage

- 14. Tested in 3x3mm 12-lead QFN-Style Package



MMIC DIE

Variable Gain Amplifier

PVGA-123-D+

50Ω 0.4 to 12 GHz

FUNCTIONAL DIAGRAM

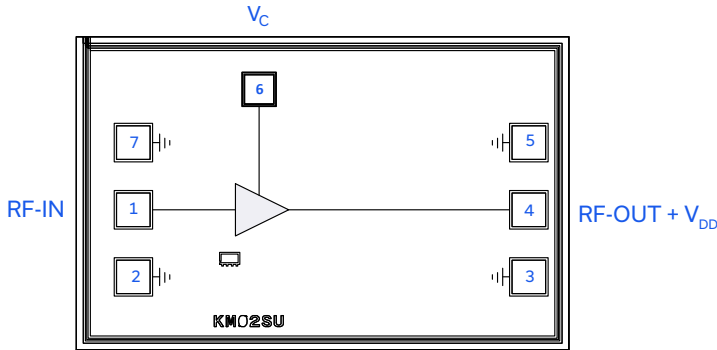

Figure 1. PVGA-123-D+ Functional Diagram

PAD DESCRIPTION

Function	Pad #	Application Description (Refer to Figure 1)
RF-IN	1	RF-IN Pad connects to RF-Input port.
RF-OUT + V _{DD}	4	RF-OUT + DC Pad connects to RF-Output and DC port.
V _c	6	DC Input Pad connects to control voltage input port V _c .
GND	2, 3, 5, 7	Connects to ground.

DIE OUTLINE: inches [mm], Typical

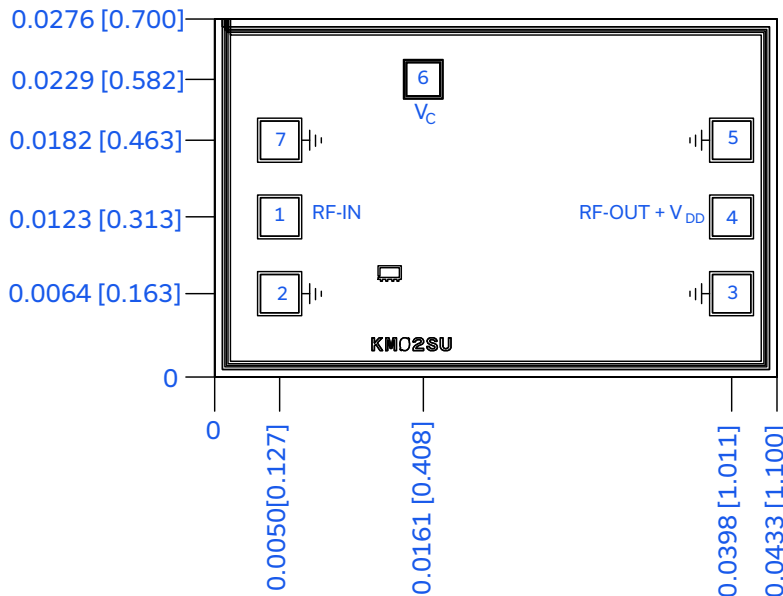

Figure 2. PVGA-123-D+ Die Outline

DIMENSIONS: inches [mm], Typical

Die Size	0.0433 x 0.0276 [1.100 x 0.700]
Die Thickness	0.0040 [0.100]
Bond Pad Sizes:	
Pad 6	0.0026 x 0.0026 [0.065 x 0.065]
Pads 1, 2, 3, 4, 5, & 7	0.0030 x 0.0030 [0.075 x 0.075]
Plating (Pads & Bottom of Die)	Gold



CHARACTERIZATION AND APPLICATION CIRCUIT

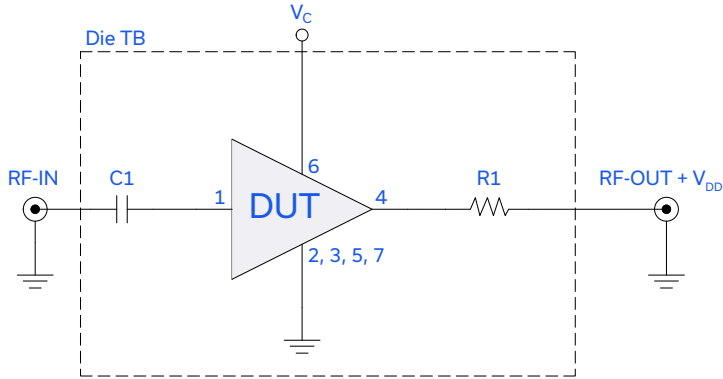

Electrical Parameters and Conditions

Gain, Return Loss, Output Power at 1dB Compression (P1dB), Output IP3 (OIP3) and Noise Figure measured using N5245A PNA-X microwave network analyzer.

Conditions:

1. Gain and Return loss: $P_{IN} = -25$ dBm
2. Output IP3 (OIP3): Two tones, spaced 1 MHz apart, -5 dBm/tone at output.

Figure 3. DUT attached to Mini-Circuits die Characterization Test Board.

Component	Value	Size	Part Number	Manufacturer
C1	100pF	0402	GRM1555C1H101JA01J	Murata
R1	0Ω	0402	RK73Z1ETTP	KOA Speer



ASSEMBLY DIAGRAM

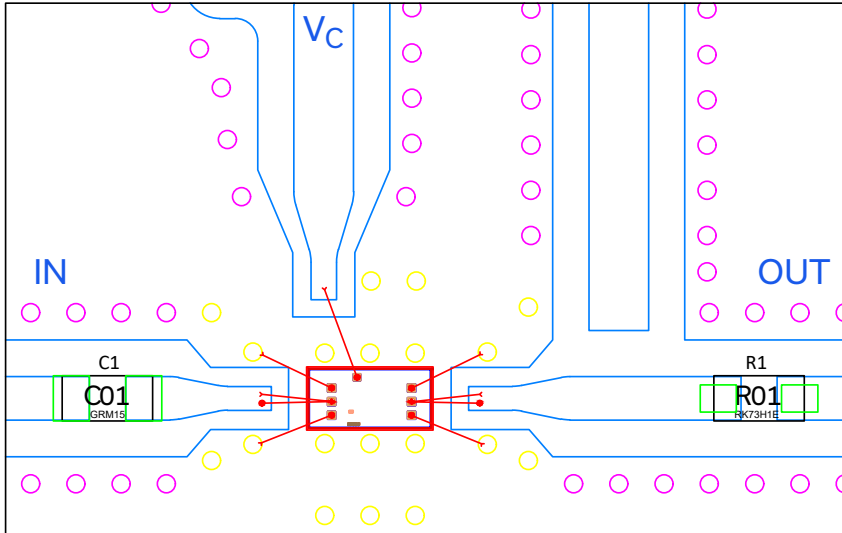

Note:
 C1 : 100pF Capacitor
 R1 : 0 Ohm Resistor

Figure 4. PVGA-123-D+ Assembly Diagram.

Refer to the table in Figure 3 for more details on the passive components.

- Bond wire diameter: 1 mil
- Bond wire lengths from Die Pad to PCB at RF-IN & RF-OUT ports: 30 ± 2 mils
- Typical Gap from Die edge to PCB edge: 3 mils
- PCB thickness and material: 10 mil RO4350B (Thickness : 1 oz copper on each side).

ASSEMBLY AND HANDLING PROCEDURE

1. Storage
Die should be stored in a dry nitrogen purged desiccator or equivalent.
2.  ESD Precautions
MMIC pHEMT amplifier die are susceptible to electrostatic and mechanical damage. Die are supplied in anti-static protected material, which should be opened only in clean room conditions at an appropriately grounded anti-static workstation.
3. Die Handling and Attachment
Devices require careful handling using tools appropriate for manipulating semiconductor chips. It is recommended to handle the chips along the edges with a custom designed collet. The surface of the chips have exposed air bridges and should not be touched with a vacuum collet, tweezers or fingers. The die mounting surface must be clean and flat. Using conductive silver-filled epoxy, apply sufficient adhesive to meet the required bond line thickness, fillet height and coverage around the total periphery of the device. The recommended epoxy is Ablestik 84-1 LMISR4 or equivalent. Parts should be cured in a nitrogen-filled atmosphere per manufacturer's recommended cure profile.
4. Wire Bonding
Openings in the surface passivation above the gold bond pads are provided to allow wire bonding to the die. Thermosonic bonding is recommended with minimized ultrasonic content. Bond force, time, ultrasonic power and temperature are all critical parameters. The suggested interconnect is pure gold, 1 mil diameter wire. Bonds are recommended to be made from the bond pads on the die to the package or substrate. All bond wire length and bond wire height should be kept as short as possible, unless specified by design, to minimize performance degradation due to undesirable series inductance.



MMIC DIE

Variable Gain Amplifier

PVGA-123-D+

50Ω 0.4 to 12 GHz

ADDITIONAL DETAILED INFORMATION IS AVAILABLE ON OUR DASH BOARD [CLICK HERE](#)

Performance Data	Table Graphs S-Parameter (S2P Files) Data Set (.zip file)	
Case Style	Die	
RoHs Status	Compliant	
Die Ordering and Packaging Information	Quantity, Package Gel-Pak: 5, 10, 50, 100 KGD* Medium†, Partial wafer: KGD*<1692 Full wafer† †Available upon request contact sales representative. Refer to AN-60-067	Model No. PVGA-123-DG+ PVGA-123-DP+ PVGA-123-DF+
Die Marking	KM02SU	
Environmental Ratings	ENV-80	

* Known Good Die ("KGD") means that the die in question have been subjected to Mini-Circuits DC test performance criteria and measurement instructions and that the parametric data of such die fall within a predefined range. While DC testing is not definitive, it does provide a higher degree of confidence that die are capable of meeting typical RF electrical parameters specified by Mini-Circuits.

Notes

- A. Performance and quality attributes and conditions not expressly stated in this specification document are intended to be excluded and do not form a part of this specification document.
- B. Electrical specifications and performance data contained in this specification document are based on Mini-Circuits' applicable established test performance criteria and measurement instructions.
- C. The parts covered by this specification document are subject to Mini-Circuits' standard limited warranty and terms and conditions (collectively, "Standard Terms"); Purchasers of this part are entitled to the rights and benefits contained there in. For a full statement of the standard. Terms and the exclusive rights and remedies thereunder, please visit Mini-Circuits' website at www.minicircuits.com/MCLStore/terms.jsp
- D. Mini-Circuits does not warrant the accuracy or completeness of the information, text, graphics and other items contained within this document and same are provided as an accommodation and on an As is basis, with all faults.
- E. Purchasers of this part are solely responsible for proper storing, handling, assembly and processing of known good die (KGD) (including, without limitation, proper ESD preventative measures, die preparation, die attach, wire bonding and related assembly and test activities), and Mini-Circuits assumes no responsibility therefor or for environmental effects on KGD.
- F. Mini-Circuits and the Mini-Circuits logo are registered trademarks of Scientific Components Corporation d/b/a Mini-Circuits. All other third-party trademarks are the property of their respective owners. A reference to any third-party trademark does not constitute or imply any endorsement, affiliation, sponsorship, or recommendation by any such third-party of Mini-Circuits or its products.



Typical Performance Data

NOTE: Use PDF Bookmarks to view DATA at required conditions

Definitions:

- Input Return Loss = -S11 (dB)
- Gain(Power Gain) = S21 (dB)
- Reverse Isolation = -S12 (dB)
- Output Return Loss = -S22 (dB)

TEST CONDITIONS: $V_{DD} = +6V$, $V_C = +5V$, $I_{DD} = 77mA @$ Temperature = +25°C

FREQ	Gain	Isolation	Input Return Loss	Output Return Loss	Stability		IP-3 Output	1dB Comp. Output	Noise Figure
					K	Measure			
(GHz)	(dB)	(dB)	(dB)	(dB)	K	Measure	(dBm)	(dBm)	(dB)
0.2	16.7	26.0	15.9	17.5	1.6	0.9	26.9	21.1	12.8
0.4	16.8	25.7	18.2	17.9	1.6	0.9	27.1	21.0	5.4
0.6	16.9	25.6	18.8	17.9	1.6	0.9	27.7	21.4	4.4
0.8	16.9	25.6	19.1	17.8	1.6	0.9	28.0	21.3	4.3
1.0	16.9	25.7	19.1	17.7	1.6	0.9	27.8	21.1	4.2
1.2	16.9	25.7	19.1	17.6	1.6	0.9	28.2	21.4	4.2
1.4	16.9	25.8	19.0	17.4	1.6	0.9	28.5	21.2	4.2
1.6	16.9	25.9	18.8	17.2	1.6	0.9	28.6	21.5	4.2
1.8	16.9	26.0	18.6	16.9	1.6	0.9	28.5	21.2	4.2
2.0	16.9	26.1	18.2	16.6	1.6	0.9	29.4	21.2	4.2
2.2	16.9	26.2	17.8	16.3	1.6	0.9	28.8	21.3	4.2
2.4	16.9	26.3	17.3	15.9	1.7	0.9	29.9	21.0	4.2
2.6	16.8	26.5	16.7	15.5	1.7	0.9	29.9	21.3	4.3
2.8	16.8	26.7	16.5	15.2	1.7	0.9	30.6	20.9	4.4
3.0	16.8	26.8	16.2	14.9	1.7	0.9	31.1	21.0	4.4
3.2	16.8	26.9	15.8	14.6	1.8	0.9	31.7	20.9	4.3
3.4	16.8	27.0	15.3	14.3	1.8	0.9	32.5	20.7	4.3
3.6	16.8	27.1	14.8	14.0	1.8	0.9	32.4	20.8	4.3
3.8	16.7	27.3	14.5	13.8	1.8	0.9	33.3	20.3	4.4
4.0	16.7	27.5	14.2	13.5	1.9	0.9	33.3	20.7	4.4
4.2	16.7	27.6	14.0	13.4	1.9	0.9	32.8	20.3	4.4
4.4	16.6	27.8	13.8	13.2	1.9	0.9	33.2	20.4	4.4
4.6	16.6	28.0	13.7	13.1	2.0	0.9	32.8	20.3	4.4
4.8	16.5	28.1	13.7	13.1	2.0	0.9	32.6	20.2	4.4
5.0	16.4	28.3	13.7	13.0	2.0	0.9	31.9	20.2	4.5
5.2	16.4	28.4	13.7	12.9	2.1	0.9	31.8	20.0	4.6
5.4	16.3	28.6	13.7	12.8	2.1	0.9	30.4	19.9	4.5
5.6	16.2	28.7	13.7	12.7	2.2	0.9	30.6	19.9	4.5
5.8	16.2	28.8	13.6	12.6	2.2	0.9	30.5	19.9	4.5
6.0	16.1	29.0	13.5	12.4	2.2	1.0	30.0	19.8	4.5
6.2	16.0	29.1	13.3	12.3	2.3	1.0	29.7	19.8	4.5
6.4	15.9	29.2	13.1	12.2	2.3	1.0	29.8	19.7	4.5
6.6	15.8	29.3	12.8	12.0	2.3	1.0	29.8	19.8	4.5
6.8	15.7	29.4	12.5	11.9	2.3	1.0	29.9	19.8	4.5
7.0	15.7	29.4	12.2	11.9	2.4	1.0	29.8	19.5	4.4
7.2	15.6	29.5	11.9	11.8	2.4	1.0	29.5	19.8	4.5
7.4	15.5	29.6	11.6	11.8	2.4	1.0	29.3	19.5	4.5
7.6	15.4	29.6	11.3	11.9	2.4	1.0	29.3	19.7	4.5
7.8	15.3	29.6	11.0	11.9	2.5	1.0	29.2	19.5	4.5
8.0	15.2	29.7	10.7	12.0	2.5	1.0	29.4	19.4	4.5
8.2	15.1	29.7	10.4	12.2	2.5	1.0	29.6	19.5	4.5
8.4	15.0	29.7	10.1	12.4	2.5	1.0	29.3	19.3	4.5
8.6	14.9	29.7	9.8	12.6	2.6	1.0	29.3	19.7	4.5
8.8	14.8	29.7	9.5	12.8	2.6	1.0	29.2	19.3	4.5
9.0	14.7	29.7	9.3	13.0	2.6	1.1	29.6	19.4	4.5
9.2	14.6	29.7	9.0	13.2	2.6	1.1	29.4	19.4	4.6
9.4	14.4	29.7	8.8	13.5	2.7	1.1	29.0	19.0	4.6
9.6	14.3	29.7	8.6	13.7	2.7	1.1	29.0	19.4	4.6
9.8	14.2	29.7	8.4	13.9	2.7	1.1	29.3	18.8	4.6
10.0	14.0	29.7	8.2	14.1	2.8	1.1	29.5	19.2	4.6
11.0	13.5	29.6	8.0	14.9	2.9	1.1	29.4	19.2	4.6
12.0	13.1	29.3	8.8	15.0	3.1	1.1	29.6	19.1	4.7
13.0	12.7	29.1	10.1	13.0	3.2	1.0	-	-	-
14.0	11.9	29.3	11.5	10.5	3.6	1.0	-	-	-
15.0	11.0	29.7	11.7	8.7	4.0	0.9	-	-	-

Typical Performance Data

NOTE: Use PDF Bookmarks to view DATA at required conditions

Definitions:

- Input Return Loss = -S11 (dB)
- Gain(Power Gain) = S21 (dB)
- Reverse Isolation = -S12 (dB)
- Output Return Loss = -S22 (dB)

TEST CONDITIONS: $V_{DD} = +6V$, $V_C = +4V$, $I_{DD} = 59mA$ @ Temperature = +25°C

FREQ	Gain	Isolation	Input Return Loss	Output Return Loss	Stability		IP-3 Output	1dB Comp. Output	Noise Figure
					K	Measure			
(GHz)	(dB)	(dB)	(dB)	(dB)	K	Measure	(dBm)	(dBm)	(dB)
0.2	16.0	25.1	17.8	25.3	1.6	0.9	24.4	21.2	13.7
0.4	16.1	24.8	21.5	25.9	1.6	0.9	24.9	21.2	5.6
0.6	16.2	24.7	22.7	25.7	1.5	0.9	25.8	21.5	4.4
0.8	16.2	24.8	23.1	25.4	1.6	0.9	26.1	21.3	4.3
1.0	16.2	24.8	23.2	25.0	1.6	0.9	25.7	21.2	4.2
1.2	16.2	24.9	23.2	24.6	1.6	0.9	26.3	21.5	4.3
1.4	16.2	24.9	23.0	24.2	1.6	0.9	26.7	21.3	4.3
1.6	16.2	25.0	22.6	23.7	1.6	0.9	26.7	21.6	4.2
1.8	16.2	25.1	22.2	23.0	1.6	0.9	26.6	21.4	4.2
2.0	16.2	25.2	21.6	22.5	1.6	0.9	27.4	21.3	4.2
2.2	16.2	25.3	20.9	21.8	1.6	0.9	27.4	21.3	4.2
2.4	16.2	25.4	20.1	21.0	1.7	0.9	28.1	21.2	4.3
2.6	16.1	25.6	19.3	20.1	1.7	0.9	28.3	21.4	4.3
2.8	16.1	25.7	19.0	19.5	1.7	0.9	28.8	21.0	4.4
3.0	16.1	25.8	18.6	18.8	1.7	0.9	29.0	21.2	4.4
3.2	16.1	25.9	18.0	18.1	1.8	0.9	29.3	21.0	4.3
3.4	16.1	26.1	17.3	17.5	1.8	0.9	30.0	21.0	4.3
3.6	16.1	26.2	16.7	16.8	1.8	0.9	30.1	21.0	4.3
3.8	16.0	26.3	16.2	16.3	1.8	0.9	30.7	20.5	4.3
4.0	16.0	26.5	15.8	15.7	1.8	0.9	31.0	21.0	4.4
4.2	15.9	26.7	15.6	15.3	1.9	0.9	30.6	20.5	4.4
4.4	15.9	26.8	15.3	14.9	1.9	0.9	30.3	20.7	4.4
4.6	15.8	27.0	15.2	14.6	1.9	0.9	30.3	20.6	4.4
4.8	15.7	27.2	15.0	14.2	2.0	0.9	30.6	20.5	4.4
5.0	15.7	27.3	15.0	13.9	2.0	0.9	30.3	20.5	4.5
5.2	15.6	27.5	14.9	13.6	2.1	0.9	30.1	20.2	4.5
5.4	15.5	27.6	14.8	13.2	2.1	0.9	28.9	20.2	4.5
5.6	15.4	27.8	14.7	12.9	2.1	0.9	29.3	20.1	4.5
5.8	15.3	27.9	14.5	12.6	2.2	0.9	28.7	20.1	4.5
6.0	15.2	28.0	14.2	12.3	2.2	0.9	28.3	20.1	4.5
6.2	15.1	28.2	13.9	12.0	2.2	1.0	28.1	20.0	4.5
6.4	15.0	28.2	13.6	11.7	2.3	1.0	27.7	19.9	4.5
6.6	14.9	28.3	13.2	11.5	2.3	1.0	27.7	20.1	4.5
6.8	14.8	28.4	12.8	11.3	2.3	1.0	27.8	20.0	4.5
7.0	14.8	28.5	12.4	11.2	2.3	1.0	27.2	19.9	4.4
7.2	14.7	28.6	12.1	11.1	2.4	1.0	27.2	20.1	4.4
7.4	14.6	28.6	11.7	11.0	2.4	1.0	27.1	19.7	4.4
7.6	14.5	28.6	11.4	11.0	2.4	1.0	27.4	20.1	4.5
7.8	14.4	28.7	11.1	11.0	2.4	1.0	27.5	19.8	4.4
8.0	14.3	28.7	10.8	11.1	2.4	1.0	26.8	19.8	4.5
8.2	14.2	28.7	10.5	11.2	2.5	1.0	27.2	19.8	4.5
8.4	14.1	28.7	10.2	11.4	2.5	1.0	27.0	19.7	4.5
8.6	14.0	28.8	9.9	11.6	2.5	1.0	27.0	19.9	4.5
8.8	13.9	28.8	9.6	11.8	2.5	1.0	26.8	19.5	4.5
9.0	13.8	28.8	9.3	11.9	2.6	1.0	27.2	19.7	4.5
9.2	13.7	28.8	9.0	12.1	2.6	1.1	26.4	19.6	4.5
9.4	13.6	28.8	8.8	12.4	2.6	1.1	26.2	19.5	4.5
9.6	13.5	28.8	8.5	12.5	2.7	1.1	26.2	19.6	4.6
9.8	13.3	28.9	8.3	12.7	2.7	1.1	26.8	19.1	4.6
10.0	13.2	28.9	8.2	12.9	2.7	1.1	26.0	19.3	4.5
11.0	12.7	28.8	7.9	13.6	2.9	1.1	26.0	19.1	4.6
12.0	12.3	28.5	8.5	14.1	3.0	1.1	26.4	19.1	4.6
13.0	12.0	28.4	9.9	12.5	3.2	1.0	-	-	-
14.0	11.3	28.6	11.3	10.2	3.5	1.0	-	-	-
15.0	10.3	29.1	11.6	8.4	3.9	0.9	-	-	-

Typical Performance Data

NOTE: Use PDF Bookmarks to view DATA at required conditions

Definitions:

- Input Return Loss = -S11 (dB)
- Gain(Power Gain) = S21 (dB)
- Reverse Isolation = -S12 (dB)
- Output Return Loss = -S22 (dB)

TEST CONDITIONS: $V_{DD} = +6V$, $V_C = +3V$, $I_{DD} = 43mA$ @ Temperature = +25°C

FREQ	Gain	Isolation	Input Return Loss	Output Return Loss	Stability		IP-3 Output	1dB Comp. Output	Noise Figure
					K	Measure			
(GHz)	(dB)	(dB)	(dB)	(dB)	K	Measure	(dBm)	(dBm)	(dB)
0.2	14.4	23.6	20.7	21.0	1.6	0.9	18.8	21.3	15.2
0.4	14.6	23.3	28.2	21.1	1.6	0.9	19.8	21.8	6.0
0.6	14.6	23.2	32.6	21.1	1.5	0.9	20.4	22.0	4.6
0.8	14.7	23.3	36.4	21.3	1.6	0.9	20.8	21.6	4.5
1.0	14.7	23.3	40.2	21.4	1.6	0.9	20.2	21.7	4.4
1.2	14.7	23.4	42.0	21.7	1.6	0.9	20.6	21.7	4.4
1.4	14.7	23.5	41.4	22.1	1.6	0.9	21.0	21.8	4.4
1.6	14.7	23.5	38.3	22.7	1.6	0.9	21.2	22.0	4.3
1.8	14.7	23.6	36.6	23.6	1.6	0.9	21.0	21.9	4.4
2.0	14.7	23.7	35.5	24.6	1.6	0.9	21.7	21.8	4.3
2.2	14.7	23.8	34.0	26.0	1.7	0.9	21.6	21.6	4.3
2.4	14.6	23.9	31.5	27.4	1.7	0.9	22.5	21.7	4.5
2.6	14.6	24.0	28.8	29.0	1.7	0.9	22.1	21.7	4.4
2.8	14.6	24.2	27.5	28.4	1.7	0.9	23.1	21.5	4.6
3.0	14.6	24.2	26.5	26.9	1.7	0.9	22.8	21.6	4.5
3.2	14.6	24.3	25.1	24.5	1.8	0.9	23.0	21.4	4.4
3.4	14.6	24.4	23.6	22.6	1.8	0.9	24.3	21.5	4.4
3.6	14.5	24.6	22.2	20.9	1.8	0.9	24.2	21.3	4.4
3.8	14.5	24.7	21.1	19.4	1.8	0.9	24.6	20.9	4.5
4.0	14.5	24.8	20.3	18.2	1.8	0.9	25.3	21.3	4.5
4.2	14.4	25.0	19.6	17.1	1.9	0.9	25.4	20.8	4.5
4.4	14.3	25.1	19.1	16.1	1.9	0.9	25.0	21.1	4.5
4.6	14.3	25.3	18.6	15.3	1.9	0.9	25.5	21.0	4.5
4.8	14.2	25.5	18.2	14.5	2.0	0.9	25.1	20.9	4.5
5.0	14.1	25.6	17.8	13.8	2.0	0.9	26.6	20.9	4.5
5.2	13.9	25.8	17.4	13.1	2.1	0.9	25.5	20.5	4.6
5.4	13.8	26.0	17.0	12.5	2.1	0.9	24.6	20.5	4.5
5.6	13.7	26.1	16.5	11.9	2.1	0.9	25.5	20.5	4.6
5.8	13.6	26.3	16.0	11.4	2.2	0.9	24.3	20.5	4.5
6.0	13.5	26.4	15.4	10.9	2.2	0.9	24.3	20.5	4.5
6.2	13.3	26.5	14.8	10.6	2.2	0.9	25.1	20.3	4.5
6.4	13.2	26.6	14.2	10.2	2.3	0.9	24.3	20.2	4.6
6.6	13.1	26.7	13.6	9.9	2.3	0.9	24.3	20.5	4.5
6.8	13.0	26.9	13.1	9.7	2.3	0.9	23.7	20.3	4.5
7.0	12.9	26.9	12.6	9.5	2.3	0.9	23.1	20.4	4.5
7.2	12.8	27.0	12.2	9.3	2.3	0.9	23.7	20.4	4.5
7.4	12.7	27.1	11.8	9.2	2.4	0.9	23.4	20.2	4.5
7.6	12.6	27.1	11.4	9.2	2.4	0.9	24.1	20.5	4.5
7.8	12.5	27.1	11.1	9.2	2.4	0.9	23.9	20.4	4.5
8.0	12.4	27.1	10.8	9.2	2.4	0.9	23.1	20.5	4.5
8.2	12.4	27.2	10.4	9.3	2.4	1.0	23.8	20.4	4.5
8.4	12.3	27.2	10.1	9.4	2.5	1.0	23.6	20.3	4.6
8.6	12.2	27.2	9.8	9.5	2.5	1.0	23.5	20.4	4.6
8.8	12.1	27.2	9.5	9.6	2.5	1.0	23.3	20.2	4.6
9.0	12.0	27.2	9.3	9.7	2.5	1.0	23.6	20.4	4.6
9.2	11.9	27.3	9.0	9.9	2.6	1.0	23.0	20.2	4.6
9.4	11.8	27.3	8.7	10.0	2.6	1.0	22.9	20.4	4.6
9.6	11.6	27.3	8.5	10.1	2.6	1.0	23.1	20.0	4.7
9.8	11.5	27.4	8.2	10.3	2.7	1.0	23.6	20.0	4.7
10.0	11.4	27.4	8.0	10.4	2.7	1.0	22.6	19.8	4.6
11.0	10.9	27.3	7.6	11.0	2.8	1.1	21.5	19.3	4.7
12.0	10.7	27.1	8.2	11.6	3.0	1.1	21.6	19.3	4.8
13.0	10.4	27.0	9.4	10.9	3.1	1.0	-	-	-
14.0	9.8	27.2	10.9	9.1	3.4	1.0	-	-	-
15.0	8.8	27.6	11.5	7.5	3.8	0.9	-	-	-

Typical Performance Data

NOTE: Use PDF Bookmarks to view DATA at required conditions

Definitions:

Input Return Loss = -S11 (dB)

Gain(Power Gain) = S21 (dB)

Reverse Isolation = -S12 (dB)

Output Return Loss = -S22 (dB)

TEST CONDITIONS: $V_{DD} = +6V$, $V_C = +2V$, $I_{DD} = 30mA$ @ Temperature = +25°C

FREQ	Gain	Isolation	Input Return Loss	Output Return Loss	Stability		IP-3 Output	1dB Comp. Output	Noise Figure
					K	Measure			
(GHz)	(dB)	(dB)	(dB)	(dB)	K	Measure	(dBm)	(dBm)	(dB)
0.2	11.0	21.3	16.4	9.3	1.6	0.8	11.0	21.5	18.2
0.4	11.2	21.1	16.5	9.5	1.6	0.8	11.8	22.1	7.2
0.6	11.3	21.1	16.4	9.6	1.6	0.8	12.1	22.2	5.2
0.8	11.3	21.1	16.4	9.7	1.6	0.8	12.4	21.7	5.0
1.0	11.3	21.2	16.5	9.8	1.6	0.8	12.0	21.8	5.0
1.2	11.3	21.2	16.6	9.9	1.6	0.8	12.2	21.7	5.0
1.4	11.3	21.3	16.8	10.1	1.6	0.8	12.4	22.0	5.0
1.6	11.3	21.3	17.0	10.2	1.7	0.8	12.5	22.1	4.9
1.8	11.2	21.4	17.4	10.5	1.7	0.8	12.4	22.2	4.9
2.0	11.2	21.5	17.8	10.7	1.7	0.8	12.8	21.9	4.9
2.2	11.2	21.6	18.5	10.9	1.7	0.8	12.8	21.8	4.9
2.4	11.2	21.6	19.3	11.2	1.8	0.8	13.4	21.9	5.0
2.6	11.2	21.7	20.3	11.6	1.8	0.8	13.1	21.9	5.0
2.8	11.2	21.8	21.1	11.8	1.8	0.8	13.6	21.8	5.1
3.0	11.2	21.9	21.8	12.0	1.8	0.9	13.4	21.9	5.1
3.2	11.2	21.9	22.9	12.2	1.8	0.9	13.5	21.7	5.0
3.4	11.2	22.0	24.1	12.2	1.9	0.9	14.0	21.9	5.0
3.6	11.2	22.0	25.4	12.2	1.9	0.9	13.9	21.5	5.0
3.8	11.1	22.1	26.4	12.1	1.9	0.9	14.0	21.3	5.0
4.0	11.1	22.3	26.9	11.8	1.9	0.9	14.0	21.6	5.0
4.2	11.0	22.4	26.3	11.5	2.0	0.9	14.1	21.1	5.0
4.4	10.9	22.5	25.0	11.1	2.0	0.9	13.7	21.6	5.0
4.6	10.8	22.7	23.4	10.7	2.0	0.9	14.0	21.4	5.0
4.8	10.6	22.9	21.9	10.3	2.1	0.9	13.8	21.4	5.0
5.0	10.5	23.0	20.6	9.8	2.1	0.9	14.1	21.3	5.0
5.2	10.3	23.2	19.3	9.4	2.2	0.9	13.7	21.0	5.1
5.4	10.1	23.4	18.1	9.0	2.2	0.9	13.0	20.9	5.0
5.6	9.9	23.6	17.0	8.5	2.3	0.8	13.4	21.0	5.0
5.8	9.8	23.8	16.0	8.2	2.3	0.8	13.0	20.8	5.0
6.0	9.6	24.0	15.1	7.8	2.4	0.8	12.8	20.9	5.0
6.2	9.4	24.1	14.3	7.5	2.4	0.8	12.9	20.6	5.0
6.4	9.2	24.3	13.6	7.3	2.4	0.8	12.7	20.6	5.0
6.6	9.0	24.4	13.0	7.0	2.5	0.8	12.8	21.0	5.0
6.8	8.9	24.6	12.4	6.8	2.5	0.8	12.6	20.8	5.0
7.0	8.7	24.7	11.9	6.7	2.6	0.8	12.3	20.9	5.0
7.2	8.6	24.8	11.5	6.5	2.6	0.8	12.5	20.8	5.0
7.4	8.5	24.8	11.2	6.4	2.6	0.8	12.4	20.7	5.0
7.6	8.4	24.9	10.8	6.4	2.7	0.8	12.6	21.0	5.0
7.8	8.3	25.0	10.6	6.4	2.7	0.8	12.7	21.0	5.0
8.0	8.2	25.0	10.3	6.4	2.7	0.8	12.3	21.0	5.1
8.2	8.1	25.0	10.0	6.4	2.7	0.8	12.5	21.0	5.0
8.4	8.0	25.1	9.8	6.4	2.8	0.8	12.4	20.9	5.1
8.6	7.9	25.1	9.5	6.5	2.8	0.8	12.6	20.9	5.1
8.8	7.8	25.1	9.3	6.5	2.9	0.9	12.4	20.9	5.1
9.0	7.7	25.2	9.0	6.6	2.9	0.9	12.6	21.0	5.1
9.2	7.6	25.2	8.8	6.7	2.9	0.9	12.4	21.0	5.1
9.4	7.5	25.3	8.5	6.8	3.0	0.9	12.5	20.9	5.1
9.6	7.3	25.3	8.3	6.8	3.0	0.9	12.7	20.7	5.2
9.8	7.2	25.3	8.1	6.9	3.1	0.9	13.2	21.0	5.2
10.0	7.1	25.4	7.9	7.0	3.1	0.9	12.8	20.5	5.2
11.0	6.6	25.4	7.4	7.4	3.3	0.9	12.7	21.2	5.3
12.0	6.5	25.2	7.8	7.9	3.4	1.0	12.6	21.3	5.4
13.0	6.3	24.8	9.0	7.8	3.5	0.9	-	-	-
14.0	5.7	24.8	10.4	6.8	3.7	0.9	-	-	-
15.0	4.9	25.0	11.7	5.7	4.0	0.8	-	-	-

Typical Performance Data

NOTE: Use PDF Bookmarks to view DATA at required conditions

Definitions:

- Input Return Loss = -S11 (dB)
- Gain(Power Gain) = S21 (dB)
- Reverse Isolation = -S12 (dB)
- Output Return Loss = -S22 (dB)

TEST CONDITIONS: $V_{DD} = +6V$, $V_C = +1V$, $I_{DD} = 14mA$ @ Temperature = +25°C

FREQ	Gain	Isolation	Input Return Loss	Output Return Loss	Stability		IP-3 Output	1dB Comp. Output	Noise Figure
					K	Measure			
(GHz)	(dB)	(dB)	(dB)	(dB)	K	Measure	(dBm)	(dBm)	(dB)
0.2	8.4	19.3	9.8	6.4	1.5	0.7	12.3	21.0	22.2
0.4	8.4	19.3	10.0	6.4	1.5	0.7	12.5	21.8	8.7
0.6	8.4	19.3	10.1	6.5	1.5	0.7	12.7	22.1	5.7
0.8	8.4	19.3	10.2	6.6	1.6	0.7	12.8	21.5	5.4
1.0	8.4	19.4	10.3	6.6	1.6	0.7	12.5	21.4	5.4
1.2	8.3	19.4	10.4	6.7	1.6	0.7	12.6	21.7	5.4
1.4	8.3	19.5	10.6	6.9	1.6	0.7	12.8	21.7	5.4
1.6	8.3	19.5	10.8	7.0	1.6	0.7	12.8	22.0	5.4
1.8	8.3	19.6	11.1	7.2	1.7	0.7	12.9	22.1	5.4
2.0	8.2	19.6	11.4	7.3	1.7	0.7	13.3	21.7	5.3
2.2	8.2	19.7	11.8	7.5	1.7	0.8	13.2	21.6	5.3
2.4	8.2	19.7	12.3	7.7	1.8	0.8	13.5	21.8	5.3
2.6	8.1	19.7	12.8	8.0	1.8	0.8	13.4	21.7	5.4
2.8	8.1	19.8	13.3	8.2	1.8	0.8	13.8	21.7	5.5
3.0	8.1	19.8	13.6	8.3	1.9	0.8	13.8	21.8	5.5
3.2	8.1	19.9	14.1	8.5	1.9	0.8	13.8	21.7	5.3
3.4	8.1	19.9	14.5	8.6	1.9	0.8	14.2	21.9	5.3
3.6	8.0	20.0	15.0	8.7	1.9	0.8	14.3	21.6	5.3
3.8	7.9	20.0	15.4	8.7	2.0	0.8	14.4	21.5	5.3
4.0	7.8	20.2	15.6	8.6	2.0	0.8	14.4	21.7	5.3
4.2	7.7	20.3	15.7	8.5	2.1	0.8	14.8	21.4	5.3
4.4	7.6	20.4	15.6	8.3	2.1	0.8	14.8	21.7	5.3
4.6	7.4	20.6	15.4	8.1	2.2	0.8	14.9	21.7	5.3
4.8	7.2	20.8	15.0	7.7	2.2	0.8	14.7	21.7	5.4
5.0	6.9	21.1	14.5	7.4	2.3	0.8	15.1	21.6	5.3
5.2	6.7	21.3	14.0	7.1	2.4	0.8	15.3	21.0	5.5
5.4	6.4	21.6	13.4	6.7	2.5	0.8	15.3	21.0	5.4
5.6	6.2	21.8	12.8	6.4	2.5	0.8	15.5	21.0	5.4
5.8	5.9	22.1	12.3	6.1	2.6	0.8	15.7	21.0	5.4
6.0	5.6	22.3	11.7	5.8	2.7	0.8	16.3	21.1	5.4
6.2	5.4	22.6	11.3	5.6	2.8	0.7	16.4	20.6	5.4
6.4	5.1	22.8	10.9	5.4	2.9	0.7	16.7	20.6	5.5
6.6	4.9	23.1	10.5	5.2	3.0	0.7	17.5	20.8	5.5
6.8	4.6	23.3	10.2	5.1	3.1	0.7	18.1	20.8	5.5
7.0	4.4	23.5	10.0	5.0	3.2	0.7	18.4	20.8	5.5
7.2	4.2	23.7	9.7	4.9	3.3	0.7	18.8	20.6	5.6
7.4	4.0	23.9	9.5	4.9	3.4	0.7	18.4	20.4	5.6
7.6	3.8	24.0	9.4	4.9	3.5	0.7	18.7	20.7	5.7
7.8	3.7	24.2	9.2	4.8	3.6	0.7	19.2	20.9	5.7
8.0	3.5	24.3	9.1	4.9	3.7	0.7	16.4	20.8	5.7
8.2	3.4	24.4	9.0	4.9	3.8	0.7	16.6	20.9	5.7
8.4	3.2	24.6	8.8	4.9	3.9	0.7	16.1	20.5	5.8
8.6	3.1	24.7	8.7	4.9	4.0	0.7	16.2	20.6	5.9
8.8	2.9	24.8	8.5	4.9	4.1	0.8	15.0	20.8	5.9
9.0	2.8	24.9	8.4	4.9	4.2	0.8	15.0	20.9	5.9
9.2	2.6	25.0	8.2	4.9	4.3	0.8	14.4	21.0	6.0
9.4	2.5	25.1	8.0	4.9	4.4	0.8	14.2	20.8	6.1
9.6	2.3	25.2	7.9	4.9	4.5	0.8	14.5	20.8	6.1
9.8	2.1	25.3	7.7	4.9	4.6	0.8	15.1	21.1	6.2
10.0	2.0	25.4	7.6	4.9	4.8	0.8	13.6	20.5	6.2
11.0	1.4	25.6	7.5	5.2	5.4	0.8	12.5	21.2	6.5
12.0	1.2	25.2	8.2	5.9	5.8	0.8	12.3	21.3	7.0
13.0	0.9	24.5	9.6	6.1	5.9	0.8	-	-	-
14.0	0.1	24.3	11.4	5.4	6.2	0.8	-	-	-
15.0	-1.0	24.2	13.6	4.5	6.5	0.7	-	-	-

Typical Performance Data

NOTE: Use PDF Bookmarks to view DATA at required conditions

Definitions:

- Input Return Loss = -S11 (dB)
- Gain(Power Gain) = S21 (dB)
- Reverse Isolation = -S12 (dB)
- Output Return Loss = -S22 (dB)

TEST CONDITIONS: $V_{DD} = +6V$, $V_C = +0.8V$, $I_{DD} = 8mA$ @ Temperature = +25°C

FREQ	Gain	Isolation	Input Return Loss	Output Return Loss	Stability		IP-3 Output	1dB Comp. Output	Noise Figure
					K	Measure			
(GHz)	(dB)	(dB)	(dB)	(dB)	K	Measure	(dBm)	(dBm)	(dB)
0.2	6.9	18.8	8.2	5.5	1.5	0.7	11.3	20.8	22.1
0.4	6.9	18.7	8.4	5.5	1.5	0.7	11.4	21.7	8.6
0.6	6.9	18.7	8.5	5.6	1.6	0.7	11.5	22.0	5.8
0.8	6.8	18.8	8.6	5.6	1.6	0.7	11.5	21.4	5.5
1.0	6.8	18.8	8.7	5.7	1.6	0.7	11.6	21.4	5.5
1.2	6.7	18.9	8.8	5.8	1.6	0.7	11.6	21.6	5.5
1.4	6.7	19.0	9.0	5.9	1.7	0.7	11.7	21.8	5.6
1.6	6.6	19.0	9.2	6.0	1.7	0.7	11.8	21.9	5.5
1.8	6.6	19.1	9.4	6.1	1.8	0.7	12.1	22.2	5.5
2.0	6.5	19.2	9.7	6.3	1.8	0.7	12.2	21.9	5.4
2.2	6.5	19.2	10.0	6.4	1.8	0.7	12.3	21.5	5.5
2.4	6.4	19.3	10.5	6.6	1.9	0.7	12.4	21.9	5.5
2.6	6.3	19.3	10.9	6.8	1.9	0.8	12.6	21.7	5.6
2.8	6.2	19.4	11.4	6.9	2.0	0.8	12.6	21.7	5.8
3.0	6.2	19.5	11.6	7.0	2.0	0.8	12.8	21.8	5.7
3.2	6.1	19.5	11.9	7.1	2.1	0.8	12.8	21.6	5.5
3.4	6.1	19.5	12.3	7.2	2.1	0.8	12.8	22.0	5.5
3.6	6.0	19.6	12.6	7.2	2.1	0.8	12.9	21.5	5.5
3.8	5.9	19.7	12.9	7.2	2.2	0.8	12.7	21.5	5.5
4.0	5.7	19.8	13.1	7.1	2.3	0.8	12.4	21.6	5.6
4.2	5.5	20.0	13.1	7.0	2.3	0.8	12.6	21.3	5.6
4.4	5.3	20.2	13.1	6.8	2.4	0.8	12.1	21.7	5.6
4.6	5.1	20.5	12.9	6.6	2.5	0.8	12.1	21.6	5.7
4.8	4.8	20.7	12.7	6.4	2.6	0.8	11.9	21.7	5.7
5.0	4.5	21.0	12.4	6.2	2.7	0.8	11.8	21.6	5.7
5.2	4.1	21.3	12.0	5.9	2.9	0.7	11.5	20.9	5.9
5.4	3.8	21.6	11.6	5.7	3.0	0.7	11.0	20.9	5.8
5.6	3.4	22.0	11.2	5.5	3.2	0.7	11.1	20.8	5.9
5.8	3.1	22.3	10.8	5.3	3.3	0.7	10.8	20.7	6.0
6.0	2.7	22.6	10.4	5.1	3.5	0.7	10.4	21.0	6.0
6.2	2.4	22.9	10.1	4.9	3.7	0.7	10.3	20.4	6.0
6.4	2.1	23.2	9.8	4.7	3.8	0.7	10.0	20.3	6.1
6.6	1.8	23.5	9.5	4.6	4.0	0.7	10.0	20.6	6.2
6.8	1.5	23.8	9.3	4.5	4.2	0.7	9.8	20.7	6.2
7.0	1.2	24.1	9.1	4.4	4.4	0.7	9.5	20.8	6.4
7.2	0.9	24.3	9.0	4.3	4.6	0.7	9.5	20.4	6.4
7.4	0.7	24.5	8.9	4.2	4.8	0.7	9.2	20.1	6.4
7.6	0.5	24.7	8.8	4.2	4.9	0.7	9.2	20.4	6.6
7.8	0.3	24.9	8.7	4.2	5.1	0.7	9.2	20.8	6.6
8.0	0.1	25.0	8.7	4.2	5.3	0.7	8.7	20.6	6.8
8.2	-0.1	25.2	8.6	4.2	5.5	0.7	8.8	20.7	6.7
8.4	-0.2	25.3	8.5	4.2	5.7	0.7	8.7	20.4	6.8
8.6	-0.4	25.4	8.4	4.2	6.0	0.7	8.7	20.3	7.0
8.8	-0.6	25.6	8.3	4.3	6.2	0.7	8.4	20.7	7.1
9.0	-0.8	25.7	8.2	4.3	6.4	0.7	8.5	20.7	7.2
9.2	-1.0	25.8	8.1	4.4	6.7	0.7	8.4	20.8	7.2
9.4	-1.2	25.9	8.0	4.5	6.9	0.7	8.4	20.7	7.4
9.6	-1.4	26.0	7.8	4.5	7.2	0.7	8.4	20.7	7.4
9.8	-1.5	26.1	7.7	4.6	7.5	0.8	8.7	21.0	7.6
10.0	-1.7	26.2	7.6	4.7	7.7	0.8	8.3	20.5	7.7
11.0	-2.4	26.3	7.6	5.1	8.9	0.8	8.1	21.0	8.1
12.0	-2.7	25.8	8.5	5.5	9.5	0.8	8.2	20.8	8.6
13.0	-3.1	25.0	10.2	5.7	9.6	0.8	-	-	-
14.0	-4.0	24.6	12.3	5.3	10.2	0.7	-	-	-
15.0	-5.1	24.4	14.6	4.5	10.7	0.7	-	-	-

Typical Performance Data

NOTE: Use PDF Bookmarks to view DATA at required conditions

Definitions:

- Input Return Loss = -S11 (dB)
- Gain(Power Gain) = S21 (dB)
- Reverse Isolation = -S12 (dB)
- Output Return Loss = -S22 (dB)

TEST CONDITIONS: $V_{DD} = +5V$, $V_C = +5V$, $I_{DD} = 72mA @$ Temperature = +25°C

FREQ	Gain	Isolation	Input Return Loss	Output Return Loss	Stability		IP-3 Output	1dB Comp. Output	Noise Figure
					K	Measure			
(GHz)	(dB)	(dB)	(dB)	(dB)	K	Measure	(dBm)	(dBm)	(dB)
0.2	16.4	25.9	16.3	18.3	1.6	0.9	26.4	19.5	12.8
0.4	16.6	25.5	18.8	18.7	1.6	0.9	26.7	19.3	5.5
0.6	16.6	25.5	19.5	18.8	1.6	0.9	27.3	19.7	4.4
0.8	16.6	25.5	19.8	18.7	1.6	0.9	27.5	19.5	4.3
1.0	16.7	25.5	19.8	18.6	1.6	0.9	27.3	19.3	4.2
1.2	16.7	25.6	19.8	18.4	1.6	0.9	27.6	19.7	4.2
1.4	16.7	25.7	19.7	18.2	1.6	0.9	28.0	19.4	4.2
1.6	16.7	25.7	19.4	18.0	1.6	0.9	28.0	19.9	4.2
1.8	16.7	25.8	19.2	17.7	1.6	0.9	28.1	19.5	4.2
2.0	16.7	25.9	18.8	17.4	1.6	0.9	28.8	19.5	4.2
2.2	16.7	26.1	18.3	17.0	1.7	0.9	28.5	19.4	4.2
2.4	16.6	26.2	17.7	16.6	1.7	0.9	29.0	19.1	4.3
2.6	16.6	26.3	17.2	16.1	1.7	0.9	29.0	19.5	4.3
2.8	16.5	26.5	16.9	15.8	1.7	0.9	30.5	18.9	4.5
3.0	16.5	26.6	16.6	15.3	1.8	0.9	30.3	19.2	4.4
3.2	16.5	26.7	16.2	15.0	1.8	0.9	30.7	18.9	4.3
3.4	16.5	26.9	15.6	14.6	1.8	0.9	31.7	18.8	4.3
3.6	16.5	27.0	15.2	14.3	1.8	0.9	31.9	18.8	4.3
3.8	16.5	27.2	14.8	14.0	1.8	0.9	32.6	18.4	4.3
4.0	16.4	27.3	14.5	13.7	1.9	0.9	33.1	18.8	4.4
4.2	16.4	27.5	14.2	13.4	1.9	0.9	34.6	18.3	4.4
4.4	16.3	27.6	14.1	13.3	1.9	0.9	33.3	18.5	4.4
4.6	16.3	27.8	13.9	13.1	2.0	0.9	33.1	18.4	4.4
4.8	16.2	28.0	13.9	13.0	2.0	0.9	32.2	18.3	4.4
5.0	16.1	28.1	13.8	12.8	2.1	0.9	31.3	18.4	4.5
5.2	16.1	28.3	13.8	12.7	2.1	0.9	30.9	18.1	4.5
5.4	16.0	28.4	13.8	12.5	2.1	0.9	30.0	18.1	4.5
5.6	15.9	28.6	13.8	12.4	2.2	0.9	29.9	18.0	4.5
5.8	15.9	28.7	13.7	12.2	2.2	0.9	29.6	18.0	4.5
6.0	15.8	28.8	13.6	12.0	2.2	0.9	28.9	18.0	4.5
6.2	15.7	28.9	13.4	11.9	2.3	1.0	29.0	18.0	4.5
6.4	15.6	29.0	13.1	11.7	2.3	1.0	28.7	17.9	4.5
6.6	15.5	29.1	12.9	11.6	2.3	1.0	28.9	18.1	4.5
6.8	15.4	29.2	12.6	11.5	2.3	1.0	28.4	18.0	4.5
7.0	15.4	29.3	12.3	11.5	2.4	1.0	28.1	17.9	4.4
7.2	15.3	29.3	12.0	11.4	2.4	1.0	28.0	18.1	4.5
7.4	15.2	29.4	11.7	11.4	2.4	1.0	27.9	17.8	4.5
7.6	15.1	29.4	11.4	11.5	2.4	1.0	27.7	18.2	4.5
7.8	15.0	29.4	11.1	11.5	2.5	1.0	27.9	17.9	4.5
8.0	14.9	29.4	10.8	11.6	2.5	1.0	27.7	17.9	4.5
8.2	14.8	29.4	10.5	11.8	2.5	1.0	27.7	17.9	4.5
8.4	14.7	29.5	10.2	12.0	2.5	1.0	27.9	17.8	4.5
8.6	14.6	29.5	9.9	12.2	2.6	1.0	27.8	18.0	4.5
8.8	14.5	29.5	9.7	12.4	2.6	1.0	27.5	17.6	4.5
9.0	14.4	29.4	9.4	12.6	2.6	1.1	27.7	17.9	4.5
9.2	14.3	29.5	9.1	12.9	2.6	1.1	27.6	17.6	4.6
9.4	14.2	29.5	8.9	13.1	2.7	1.1	27.5	17.7	4.6
9.6	14.0	29.5	8.7	13.3	2.7	1.1	27.4	17.6	4.6
9.8	13.9	29.5	8.5	13.6	2.7	1.1	27.6	17.3	4.6
10.0	13.8	29.5	8.3	13.8	2.8	1.1	27.5	17.5	4.6
11.0	13.2	29.3	8.1	14.5	2.9	1.1	27.1	17.2	4.6
12.0	12.9	29.0	8.9	14.5	3.0	1.1	27.5	17.2	4.7
13.0	12.5	28.9	10.3	12.5	3.2	1.0	-	-	-
14.0	11.7	29.0	11.8	10.2	3.5	1.0	-	-	-
15.0	10.8	29.4	12.0	8.5	3.9	0.9	-	-	-

Typical Performance Data

NOTE: Use PDF Bookmarks to view DATA at required conditions

Definitions:

- Input Return Loss = -S11 (dB)
- Gain(Power Gain) = S21 (dB)
- Reverse Isolation = -S12 (dB)
- Output Return Loss = -S22 (dB)

TEST CONDITIONS: $V_{DD} = +5V$, $V_C = +4V$, $I_{DD} = 55mA @$ Temperature = +25°C

FREQ	Gain	Isolation	Input Return Loss	Output Return Loss	Stability		IP-3 Output	1dB Comp. Output	Noise Figure
					K	Measure			
(GHz)	(dB)	(dB)	(dB)	(dB)	K	Measure	(dBm)	(dBm)	(dB)
0.2	15.6	24.9	18.3	29.9	1.6	0.9	23.6	19.4	13.7
0.4	15.8	24.6	22.7	30.9	1.6	0.9	24.2	19.0	5.7
0.6	15.8	24.5	24.2	30.6	1.6	0.9	24.9	19.5	4.5
0.8	15.8	24.5	24.8	29.9	1.6	0.9	25.1	19.4	4.4
1.0	15.9	24.6	25.0	29.3	1.6	0.9	24.8	19.1	4.3
1.2	15.9	24.6	24.9	28.6	1.6	0.9	25.3	19.6	4.3
1.4	15.9	24.7	24.6	27.9	1.6	0.9	25.6	19.2	4.3
1.6	15.9	24.8	24.1	27.1	1.6	0.9	25.6	19.6	4.2
1.8	15.8	24.9	23.6	26.3	1.6	0.9	25.6	19.2	4.3
2.0	15.8	25.0	23.0	25.4	1.6	0.9	26.4	19.3	4.2
2.2	15.8	25.1	22.1	24.4	1.7	0.9	26.4	19.3	4.2
2.4	15.8	25.2	21.2	23.2	1.7	0.9	27.1	18.9	4.3
2.6	15.8	25.3	20.3	21.9	1.7	0.9	26.9	19.3	4.3
2.8	15.7	25.5	19.9	21.1	1.7	0.9	27.9	18.8	4.5
3.0	15.7	25.6	19.4	20.1	1.8	0.9	28.0	19.0	4.4
3.2	15.7	25.7	18.7	19.1	1.8	0.9	28.0	18.8	4.4
3.4	15.7	25.8	18.0	18.3	1.8	0.9	29.5	18.7	4.3
3.6	15.7	26.0	17.3	17.4	1.8	0.9	29.6	18.8	4.3
3.8	15.7	26.1	16.8	16.7	1.8	0.9	30.2	18.3	4.4
4.0	15.6	26.2	16.4	16.0	1.9	0.9	31.7	18.7	4.4
4.2	15.6	26.4	16.0	15.4	1.9	0.9	30.8	18.3	4.4
4.4	15.5	26.6	15.8	14.9	1.9	0.9	30.2	18.4	4.4
4.6	15.4	26.7	15.5	14.5	2.0	0.9	30.9	18.3	4.4
4.8	15.4	26.9	15.4	14.0	2.0	0.9	30.6	18.2	4.4
5.0	15.3	27.1	15.3	13.6	2.0	0.9	30.6	18.2	4.5
5.2	15.2	27.2	15.2	13.2	2.1	0.9	29.6	18.0	4.6
5.4	15.1	27.4	15.0	12.8	2.1	0.9	28.6	18.1	4.5
5.6	15.0	27.5	14.9	12.4	2.1	0.9	28.5	17.9	4.5
5.8	14.9	27.7	14.7	12.1	2.2	0.9	28.1	17.9	4.5
6.0	14.8	27.8	14.4	11.7	2.2	0.9	27.5	17.9	4.5
6.2	14.7	27.9	14.0	11.5	2.2	0.9	27.1	17.8	4.5
6.4	14.6	28.0	13.7	11.2	2.3	0.9	26.9	17.8	4.5
6.6	14.5	28.1	13.3	11.0	2.3	0.9	26.7	17.9	4.5
6.8	14.4	28.2	12.9	10.8	2.3	1.0	26.5	17.8	4.5
7.0	14.3	28.2	12.5	10.7	2.3	1.0	25.9	17.7	4.4
7.2	14.2	28.3	12.2	10.6	2.4	1.0	26.0	17.9	4.4
7.4	14.2	28.3	11.8	10.5	2.4	1.0	25.7	17.6	4.4
7.6	14.1	28.3	11.5	10.5	2.4	1.0	25.7	18.0	4.5
7.8	14.0	28.4	11.2	10.6	2.4	1.0	25.9	17.6	4.5
8.0	13.9	28.4	10.9	10.6	2.4	1.0	25.6	17.6	4.5
8.2	13.8	28.4	10.6	10.7	2.5	1.0	25.7	17.6	4.5
8.4	13.7	28.4	10.3	10.9	2.5	1.0	25.5	17.4	4.5
8.6	13.6	28.4	10.0	11.1	2.5	1.0	25.6	17.8	4.5
8.8	13.5	28.4	9.7	11.3	2.5	1.0	25.2	17.3	4.5
9.0	13.4	28.4	9.4	11.5	2.5	1.0	25.4	17.5	4.5
9.2	13.3	28.4	9.1	11.7	2.6	1.0	24.9	17.4	4.5
9.4	13.2	28.5	8.9	11.9	2.6	1.1	24.6	17.2	4.5
9.6	13.0	28.5	8.6	12.1	2.6	1.1	24.6	17.5	4.6
9.8	12.9	28.5	8.4	12.3	2.7	1.1	25.3	17.0	4.6
10.0	12.8	28.5	8.3	12.5	2.7	1.1	24.5	17.4	4.6
11.0	12.3	28.4	8.0	13.2	2.8	1.1	24.0	17.3	4.6
12.0	12.0	28.1	8.6	13.5	3.0	1.1	24.6	17.2	4.8
13.0	11.7	28.0	10.0	12.0	3.1	1.0	-	-	-
14.0	10.9	28.2	11.5	9.8	3.4	1.0	-	-	-
15.0	10.0	28.6	11.9	8.2	3.8	0.9	-	-	-

Typical Performance Data

NOTE: Use PDF Bookmarks to view DATA at required conditions

Definitions:

- Input Return Loss = -S11 (dB)
- Gain(Power Gain) = S21 (dB)
- Reverse Isolation = -S12 (dB)
- Output Return Loss = -S22 (dB)

TEST CONDITIONS: $V_{DD} = +5V$, $V_C = +3V$, $I_{DD} = 41mA$ @ Temperature = +25°C

FREQ	Gain	Isolation	Input Return Loss	Output Return Loss	Stability		IP-3 Output	1dB Comp. Output	Noise Figure
					K	Measure			
(GHz)	(dB)	(dB)	(dB)	(dB)	K	Measure	(dBm)	(dBm)	(dB)
0.2	13.89	23.28	20.88	17.97	1.61	0.88	17.4	19.6	15.3
0.4	14.07	22.99	27.24	18.09	1.57	0.86	18.4	19.8	6.1
0.6	14.12	22.97	29.81	18.19	1.56	0.86	18.9	20.1	4.7
0.8	14.14	22.99	31.16	18.36	1.57	0.86	19.3	19.7	4.5
1.0	14.14	23.03	31.90	18.52	1.58	0.86	18.8	19.8	4.5
1.2	14.14	23.10	32.33	18.74	1.59	0.86	19.1	19.9	4.5
1.4	14.13	23.16	32.95	19.08	1.60	0.87	19.4	19.9	4.5
1.6	14.14	23.24	33.71	19.53	1.62	0.87	19.5	20.2	4.4
1.8	14.12	23.32	34.32	20.12	1.64	0.88	19.3	20.0	4.4
2.0	14.12	23.40	35.45	20.75	1.66	0.88	20.0	19.9	4.4
2.2	14.12	23.50	36.32	21.49	1.67	0.88	19.9	19.8	4.4
2.4	14.10	23.60	35.23	22.25	1.70	0.89	20.6	19.7	4.5
2.6	14.05	23.71	32.72	23.06	1.73	0.90	20.3	19.9	4.5
2.8	14.03	23.86	31.09	23.29	1.76	0.90	21.1	19.4	4.6
3.0	14.02	23.94	29.97	23.27	1.77	0.90	20.9	19.7	4.6
3.2	14.03	24.02	28.06	22.15	1.78	0.90	21.0	19.2	4.5
3.4	14.04	24.12	25.97	20.96	1.80	0.91	21.9	19.3	4.5
3.6	14.02	24.21	24.12	19.64	1.81	0.91	21.8	19.2	4.5
3.8	13.98	24.35	22.76	18.41	1.84	0.91	22.1	18.6	4.5
4.0	13.94	24.48	21.69	17.28	1.86	0.91	22.4	19.3	4.5
4.2	13.87	24.63	20.84	16.27	1.89	0.91	22.5	18.5	4.5
4.4	13.80	24.78	20.15	15.33	1.92	0.91	22.1	18.8	4.5
4.6	13.70	24.94	19.54	14.52	1.95	0.92	22.7	18.7	4.5
4.8	13.60	25.12	19.01	13.76	1.99	0.92	22.4	18.6	4.6
5.0	13.48	25.28	18.50	13.06	2.03	0.92	23.4	18.7	4.6
5.2	13.36	25.45	18.02	12.40	2.07	0.92	22.6	18.3	4.7
5.4	13.24	25.60	17.49	11.79	2.11	0.91	21.8	18.3	4.6
5.6	13.11	25.76	16.90	11.24	2.14	0.91	22.5	18.2	4.6
5.8	12.99	25.91	16.27	10.75	2.18	0.91	21.6	18.2	4.6
6.0	12.85	26.05	15.62	10.31	2.21	0.91	21.7	18.3	4.6
6.2	12.71	26.18	14.98	9.93	2.24	0.91	22.1	18.2	4.6
6.4	12.59	26.28	14.36	9.61	2.27	0.91	21.7	18.1	4.6
6.6	12.47	26.39	13.78	9.33	2.30	0.91	21.8	18.4	4.6
6.8	12.36	26.48	13.24	9.10	2.32	0.91	21.4	18.2	4.6
7.0	12.25	26.56	12.74	8.93	2.34	0.91	20.9	18.2	4.6
7.2	12.15	26.62	12.28	8.79	2.36	0.91	21.4	18.3	4.6
7.4	12.06	26.67	11.89	8.69	2.38	0.91	21.2	18.2	4.6
7.6	11.97	26.69	11.52	8.65	2.39	0.92	21.8	18.5	4.6
7.8	11.89	26.72	11.18	8.65	2.41	0.92	21.9	18.3	4.6
8.0	11.80	26.74	10.86	8.68	2.43	0.93	21.0	18.4	4.6
8.2	11.72	26.74	10.56	8.75	2.45	0.94	21.8	18.3	4.6
8.4	11.63	26.75	10.26	8.88	2.47	0.95	21.6	18.3	4.6
8.6	11.56	26.76	9.96	8.98	2.49	0.96	21.8	18.4	4.6
8.8	11.47	26.78	9.67	9.13	2.52	0.97	21.6	18.2	4.6
9.0	11.35	26.78	9.38	9.25	2.54	0.98	21.9	18.5	4.6
9.2	11.26	26.79	9.09	9.42	2.57	0.99	21.7	18.3	4.7
9.4	11.14	26.85	8.83	9.58	2.61	1.00	21.7	18.4	4.7
9.6	11.02	26.85	8.57	9.70	2.63	1.01	21.9	18.1	4.7
9.8	10.89	26.87	8.34	9.85	2.66	1.02	22.9	18.2	4.7
10.0	10.77	26.89	8.15	9.99	2.70	1.03	21.9	17.9	4.7
11.0	10.33	26.82	7.70	10.57	2.83	1.06	20.0	17.5	4.7
12.0	10.12	26.56	8.23	11.05	2.93	1.05	20.0	17.5	4.9
13.0	9.89	26.39	9.53	10.35	3.05	1.01	-	-	-
14.0	9.23	26.59	11.02	8.71	3.32	0.94	-	-	-
15.0	8.33	26.98	11.76	7.25	3.65	0.87	-	-	-

Typical Performance Data

NOTE: Use PDF Bookmarks to view DATA at required conditions

Definitions:

- Input Return Loss = -S11 (dB)
- Gain(Power Gain) = S21 (dB)
- Reverse Isolation = -S12 (dB)
- Output Return Loss = -S22 (dB)

TEST CONDITIONS: $V_{DD} = +5V$, $V_C = +2V$, $I_{DD} = 29mA$ @ Temperature = +25°C

FREQ	Gain	Isolation	Input Return Loss	Output Return Loss	Stability		IP-3 Output	1dB Comp. Output	Noise Figure
					K	Measure			
(GHz)	(dB)	(dB)	(dB)	(dB)	K	Measure	(dBm)	(dBm)	(dB)
0.2	10.5	21.1	15.8	8.6	1.6	0.8	10.4	19.6	18.4
0.4	10.7	20.9	15.7	8.8	1.6	0.8	11.1	20.0	7.4
0.6	10.7	20.9	15.6	8.9	1.6	0.8	11.3	20.1	5.4
0.8	10.7	20.9	15.6	9.0	1.6	0.8	11.6	19.7	5.2
1.0	10.7	21.0	15.7	9.1	1.6	0.8	11.3	19.8	5.1
1.2	10.7	21.0	15.8	9.2	1.6	0.8	11.4	19.8	5.1
1.4	10.7	21.1	16.0	9.4	1.7	0.8	11.7	20.0	5.1
1.6	10.7	21.1	16.2	9.5	1.7	0.8	11.8	20.1	5.1
1.8	10.7	21.2	16.5	9.7	1.7	0.8	11.6	20.2	5.1
2.0	10.6	21.3	16.9	9.9	1.7	0.8	12.0	20.0	5.0
2.2	10.6	21.3	17.5	10.2	1.8	0.8	12.0	19.8	5.0
2.4	10.6	21.4	18.3	10.4	1.8	0.8	12.5	20.0	5.1
2.6	10.6	21.5	19.2	10.8	1.8	0.8	12.2	19.9	5.1
2.8	10.6	21.6	19.9	11.0	1.8	0.8	12.7	19.9	5.3
3.0	10.6	21.6	20.4	11.2	1.9	0.8	12.6	20.0	5.2
3.2	10.6	21.7	21.4	11.3	1.9	0.8	12.6	19.7	5.1
3.4	10.6	21.7	22.5	11.3	1.9	0.9	13.1	20.0	5.1
3.6	10.6	21.8	23.6	11.3	1.9	0.9	13.0	19.5	5.1
3.8	10.5	21.9	24.6	11.2	1.9	0.9	13.1	19.3	5.1
4.0	10.5	22.0	25.2	11.0	2.0	0.9	13.0	19.8	5.1
4.2	10.4	22.1	25.2	10.8	2.0	0.9	13.2	18.9	5.1
4.4	10.3	22.3	24.4	10.4	2.0	0.9	12.8	19.5	5.1
4.6	10.2	22.4	23.1	10.1	2.1	0.9	13.1	19.2	5.1
4.8	10.0	22.6	21.7	9.7	2.1	0.9	12.8	19.2	5.1
5.0	9.8	22.8	20.4	9.3	2.2	0.8	13.1	19.2	5.1
5.2	9.7	23.0	19.2	8.9	2.2	0.8	12.7	18.8	5.3
5.4	9.5	23.1	18.1	8.5	2.3	0.8	12.2	18.6	5.1
5.6	9.3	23.3	17.0	8.1	2.3	0.8	12.5	18.6	5.1
5.8	9.1	23.5	16.0	7.8	2.4	0.8	12.1	18.5	5.1
6.0	8.9	23.7	15.1	7.5	2.4	0.8	11.9	18.6	5.1
6.2	8.7	23.8	14.3	7.2	2.5	0.8	12.0	18.5	5.1
6.4	8.5	24.0	13.6	6.9	2.5	0.8	11.8	18.4	5.1
6.6	8.4	24.1	13.0	6.7	2.5	0.8	11.9	18.9	5.1
6.8	8.2	24.3	12.4	6.5	2.6	0.8	11.8	18.6	5.1
7.0	8.0	24.4	12.0	6.4	2.6	0.8	11.5	18.7	5.1
7.2	7.9	24.5	11.6	6.3	2.6	0.8	11.7	18.7	5.1
7.4	7.8	24.5	11.2	6.2	2.7	0.8	11.6	18.7	5.1
7.6	7.7	24.6	10.9	6.1	2.7	0.8	11.7	19.1	5.1
7.8	7.6	24.6	10.6	6.1	2.7	0.8	11.8	19.0	5.1
8.0	7.5	24.7	10.4	6.1	2.8	0.8	11.5	19.1	5.2
8.2	7.4	24.7	10.1	6.1	2.8	0.8	11.6	19.0	5.2
8.4	7.3	24.7	9.9	6.2	2.8	0.8	11.5	19.1	5.2
8.6	7.2	24.8	9.6	6.2	2.9	0.8	11.7	19.0	5.2
8.8	7.1	24.8	9.4	6.3	2.9	0.8	11.5	19.0	5.2
9.0	7.0	24.8	9.2	6.4	3.0	0.9	11.7	19.2	5.2
9.2	6.9	24.9	8.9	6.5	3.0	0.9	11.5	19.0	5.3
9.4	6.7	24.9	8.6	6.6	3.1	0.9	11.6	19.3	5.3
9.6	6.6	24.9	8.4	6.6	3.1	0.9	11.7	18.8	5.3
9.8	6.5	25.0	8.2	6.7	3.1	0.9	12.1	19.4	5.3
10.0	6.3	25.0	8.0	6.8	3.2	0.9	11.7	18.7	5.3
11.0	5.9	25.0	7.5	7.2	3.4	0.9	11.6	19.6	5.4
12.0	5.8	24.7	7.9	7.6	3.5	0.9	11.6	19.6	5.5
13.0	5.6	24.3	9.1	7.5	3.6	0.9	-	-	-
14.0	5.0	24.3	10.6	6.6	3.8	0.8	-	-	-
15.0	4.1	24.5	12.0	5.6	4.0	0.8	-	-	-

Typical Performance Data

NOTE: Use PDF Bookmarks to view DATA at required conditions

Definitions:

- Input Return Loss = -S11 (dB)
- Gain(Power Gain) = S21 (dB)
- Reverse Isolation = -S12 (dB)
- Output Return Loss = -S22 (dB)

TEST CONDITIONS: $V_{DD} = +5V$, $V_C = +1V$, $I_{DD} = 13mA @$ Temperature = +25°C

FREQ	Gain	Isolation	Input Return Loss	Output Return Loss	Stability		IP-3 Output	1dB Comp. Output	Noise Figure
					K	Measure			
(GHz)	(dB)	(dB)	(dB)	(dB)	K	Measure	(dBm)	(dBm)	(dB)
0.2	8.33	19.28	9.73	6.38	1.51	0.69	12.4	18.9	22.3
0.4	8.33	19.21	9.96	6.42	1.52	0.69	12.6	19.6	8.8
0.6	8.32	19.24	10.05	6.46	1.53	0.69	12.8	19.8	5.7
0.8	8.30	19.27	10.14	6.51	1.55	0.69	12.8	19.2	5.4
1.0	8.27	19.32	10.24	6.59	1.57	0.70	12.7	19.2	5.4
1.2	8.24	19.38	10.37	6.66	1.59	0.71	12.7	19.5	5.4
1.4	8.20	19.43	10.55	6.77	1.61	0.71	12.9	19.5	5.4
1.6	8.17	19.49	10.77	6.91	1.64	0.72	12.9	19.8	5.4
1.8	8.13	19.54	11.03	7.07	1.67	0.73	13.0	19.9	5.4
2.0	8.10	19.59	11.32	7.24	1.70	0.74	13.3	19.5	5.3
2.2	8.08	19.62	11.72	7.44	1.73	0.75	13.2	19.4	5.3
2.4	8.06	19.67	12.19	7.66	1.76	0.76	13.5	19.6	5.4
2.6	8.02	19.66	12.73	7.97	1.80	0.78	13.5	19.6	5.4
2.8	7.96	19.77	13.22	8.14	1.84	0.78	13.8	19.6	5.6
3.0	7.94	19.80	13.55	8.32	1.87	0.79	13.8	19.7	5.5
3.2	7.93	19.81	13.97	8.50	1.88	0.80	13.8	19.6	5.4
3.4	7.92	19.85	14.43	8.61	1.91	0.80	14.2	19.9	5.3
3.6	7.87	19.89	14.91	8.70	1.93	0.81	14.3	19.6	5.3
3.8	7.79	19.99	15.28	8.69	1.97	0.81	14.4	19.4	5.3
4.0	7.70	20.08	15.55	8.62	2.01	0.81	14.4	19.7	5.3
4.2	7.56	20.22	15.66	8.46	2.05	0.81	14.8	19.4	5.3
4.4	7.41	20.37	15.59	8.24	2.10	0.81	14.7	19.8	5.3
4.6	7.21	20.57	15.34	7.96	2.16	0.80	14.9	19.7	5.3
4.8	7.00	20.77	14.97	7.65	2.22	0.80	14.6	19.8	5.4
5.0	6.76	21.01	14.50	7.32	2.30	0.79	15.0	19.7	5.4
5.2	6.51	21.25	13.95	6.99	2.37	0.78	15.2	19.1	5.5
5.4	6.25	21.50	13.38	6.66	2.45	0.78	15.2	19.1	5.4
5.6	5.98	21.76	12.80	6.35	2.53	0.77	15.4	19.2	5.4
5.8	5.72	22.00	12.24	6.08	2.61	0.76	15.6	19.1	5.5
6.0	5.44	22.26	11.74	5.83	2.70	0.75	16.4	19.3	5.4
6.2	5.18	22.50	11.28	5.62	2.79	0.74	16.6	18.8	5.4
6.4	4.93	22.73	10.88	5.42	2.87	0.74	17.0	18.8	5.5
6.6	4.68	22.97	10.53	5.26	2.97	0.73	17.7	19.2	5.5
6.8	4.45	23.20	10.23	5.12	3.07	0.73	18.4	19.1	5.5
7.0	4.23	23.40	9.96	5.02	3.17	0.72	19.7	19.1	5.6
7.2	4.03	23.59	9.74	4.93	3.27	0.72	20.0	19.0	5.6
7.4	3.84	23.75	9.56	4.88	3.37	0.72	20.8	18.8	5.6
7.6	3.66	23.90	9.40	4.85	3.47	0.72	21.3	19.1	5.7
7.8	3.50	24.04	9.26	4.83	3.58	0.72	22.0	19.4	5.7
8.0	3.34	24.16	9.14	4.84	3.68	0.73	18.2	19.2	5.8
8.2	3.19	24.29	9.00	4.85	3.79	0.73	18.4	19.3	5.8
8.4	3.06	24.43	8.85	4.86	3.90	0.74	17.5	19.0	5.8
8.6	2.91	24.53	8.71	4.88	4.00	0.74	17.7	19.1	5.9
8.8	2.75	24.64	8.56	4.90	4.12	0.75	16.1	19.2	5.9
9.0	2.60	24.73	8.41	4.91	4.21	0.75	16.0	19.3	6.0
9.2	2.44	24.85	8.23	4.91	4.32	0.76	15.4	19.5	6.0
9.4	2.28	24.97	8.07	4.92	4.44	0.77	15.1	19.3	6.1
9.6	2.11	25.05	7.92	4.92	4.54	0.77	15.4	19.3	6.2
9.8	1.94	25.15	7.77	4.94	4.66	0.78	15.9	19.5	6.3
10.0	1.77	25.22	7.66	4.96	4.78	0.78	14.2	19.0	6.3
11.0	1.16	25.36	7.51	5.25	5.36	0.81	13.0	19.8	6.6
12.0	0.94	25.07	8.20	5.90	5.81	0.84	12.8	20.1	7.0
13.0	0.63	24.38	9.64	6.16	5.96	0.83	-	-	-
14.0	-0.16	24.16	11.48	5.39	6.22	0.76	-	-	-
15.0	-1.26	24.10	13.75	4.51	6.56	0.67	-	-	-

Typical Performance Data

NOTE: Use PDF Bookmarks to view DATA at required conditions

Definitions:

- Input Return Loss = -S11 (dB)
- Gain(Power Gain) = S21 (dB)
- Reverse Isolation = -S12 (dB)
- Output Return Loss = -S22 (dB)

TEST CONDITIONS: $V_{DD} = +5V$, $V_C = +0.8V$, $I_{DD} = 7mA$ @ Temperature = +25°C

FREQ	Gain	Isolation	Input Return Loss	Output Return Loss	Stability		IP-3 Output	1dB Comp. Output	Noise Figure
					K	Measure			
(GHz)	(dB)	(dB)	(dB)	(dB)	K	Measure	(dBm)	(dBm)	(dB)
0.2	6.5	18.7	8.0	5.3	1.5	0.7	10.9	18.7	22.2
0.4	6.5	18.6	8.2	5.4	1.6	0.7	11.0	19.3	8.8
0.6	6.5	18.7	8.3	5.4	1.6	0.7	11.0	19.7	5.9
0.8	6.4	18.7	8.4	5.5	1.6	0.7	11.1	19.1	5.6
1.0	6.4	18.8	8.5	5.5	1.6	0.7	11.1	19.0	5.6
1.2	6.3	18.8	8.6	5.6	1.7	0.7	11.2	19.5	5.6
1.4	6.2	18.9	8.8	5.7	1.7	0.7	11.3	19.4	5.7
1.6	6.2	19.0	9.0	5.8	1.7	0.7	11.3	19.7	5.6
1.8	6.1	19.0	9.2	6.0	1.8	0.7	11.7	19.8	5.6
2.0	6.0	19.1	9.5	6.1	1.8	0.7	11.7	19.4	5.6
2.2	6.0	19.2	9.9	6.3	1.9	0.7	11.7	19.3	5.6
2.4	5.9	19.2	10.3	6.4	1.9	0.7	11.7	19.5	5.6
2.6	5.8	19.2	10.7	6.6	2.0	0.8	11.7	19.5	5.7
2.8	5.7	19.3	11.2	6.7	2.0	0.8	11.7	19.4	5.9
3.0	5.6	19.4	11.4	6.8	2.1	0.8	11.6	19.5	5.8
3.2	5.6	19.4	11.7	6.9	2.1	0.8	11.5	19.5	5.7
3.4	5.5	19.5	12.1	7.0	2.2	0.8	11.4	19.7	5.6
3.6	5.4	19.6	12.4	7.0	2.2	0.8	11.4	19.4	5.7
3.8	5.3	19.7	12.6	7.0	2.3	0.8	11.2	19.3	5.7
4.0	5.1	19.8	12.8	6.9	2.3	0.8	10.9	19.5	5.7
4.2	4.9	20.0	12.9	6.8	2.4	0.8	11.0	19.2	5.8
4.4	4.7	20.2	12.8	6.6	2.5	0.8	10.7	19.6	5.8
4.6	4.4	20.4	12.7	6.4	2.6	0.8	10.7	19.6	5.8
4.8	4.1	20.7	12.5	6.2	2.7	0.8	10.5	19.7	5.9
5.0	3.8	21.0	12.2	6.0	2.9	0.7	10.4	19.6	5.9
5.2	3.4	21.3	11.8	5.8	3.0	0.7	10.2	18.9	6.1
5.4	3.1	21.6	11.4	5.6	3.2	0.7	9.9	18.9	6.0
5.6	2.7	22.0	11.0	5.3	3.4	0.7	9.9	19.0	6.1
5.8	2.4	22.3	10.6	5.2	3.5	0.7	9.7	18.9	6.1
6.0	2.0	22.6	10.3	5.0	3.7	0.7	9.4	19.1	6.2
6.2	1.7	22.9	10.0	4.8	3.9	0.7	9.4	18.6	6.2
6.4	1.3	23.2	9.7	4.6	4.1	0.7	9.2	18.6	6.3
6.6	1.0	23.5	9.4	4.5	4.3	0.7	9.1	18.9	6.4
6.8	0.7	23.8	9.3	4.4	4.5	0.7	9.0	19.0	6.5
7.0	0.4	24.1	9.1	4.3	4.7	0.7	8.7	19.0	6.6
7.2	0.2	24.3	9.0	4.2	4.9	0.7	8.7	18.8	6.7
7.4	-0.1	24.5	8.9	4.2	5.1	0.7	8.5	18.6	6.7
7.6	-0.3	24.7	8.8	4.1	5.3	0.7	8.5	18.9	6.9
7.8	-0.5	24.9	8.7	4.1	5.5	0.7	8.5	19.3	6.9
8.0	-0.7	25.0	8.6	4.1	5.7	0.7	8.1	19.1	7.1
8.2	-0.9	25.2	8.6	4.1	6.0	0.7	8.2	19.2	7.1
8.4	-1.0	25.3	8.5	4.2	6.2	0.7	8.1	19.0	7.1
8.6	-1.2	25.4	8.4	4.2	6.4	0.7	8.1	19.1	7.4
8.8	-1.4	25.6	8.3	4.3	6.7	0.7	7.9	19.3	7.4
9.0	-1.6	25.7	8.2	4.3	7.0	0.7	8.0	19.3	7.5
9.2	-1.8	25.8	8.1	4.4	7.3	0.7	7.9	19.4	7.6
9.4	-2.0	25.9	8.0	4.5	7.6	0.7	7.8	19.3	7.7
9.6	-2.2	26.0	7.8	4.5	7.8	0.7	7.9	19.3	7.8
9.8	-2.4	26.1	7.7	4.6	8.1	0.8	8.1	19.7	8.0
10.0	-2.6	26.2	7.7	4.7	8.5	0.8	7.8	19.1	8.0
11.0	-3.3	26.2	7.7	5.1	9.7	0.8	7.6	19.9	8.5
12.0	-3.6	25.8	8.6	5.5	10.3	0.8	7.8	19.8	9.4
13.0	-4.0	24.9	10.2	5.7	10.4	0.8	-	-	-
14.0	-4.8	24.5	12.4	5.2	11.0	0.7	-	-	-
15.0	-6.0	24.3	14.7	4.5	11.5	0.7	-	-	-

Typical Performance Curves

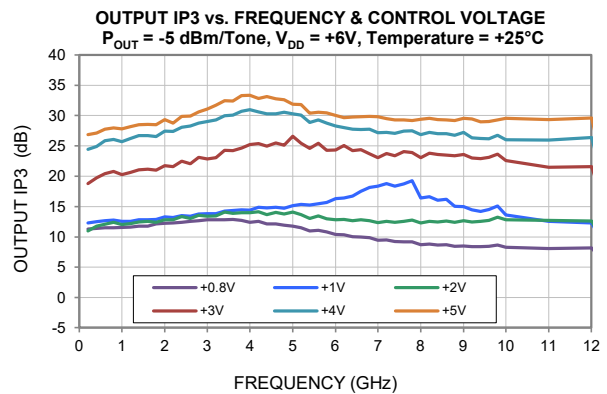
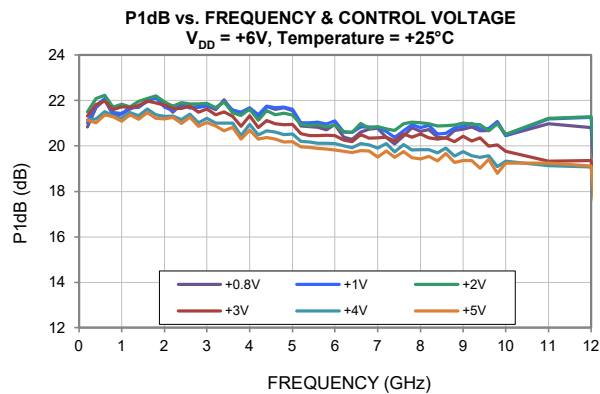
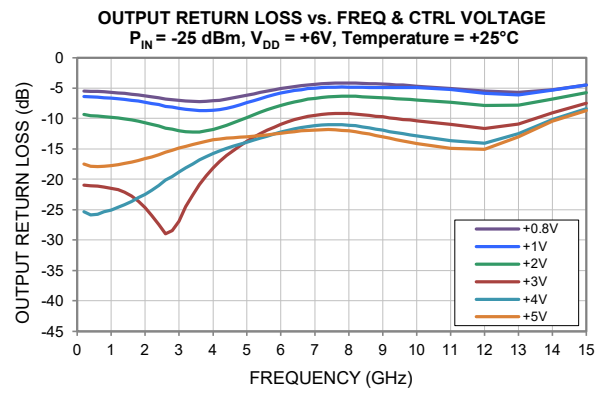
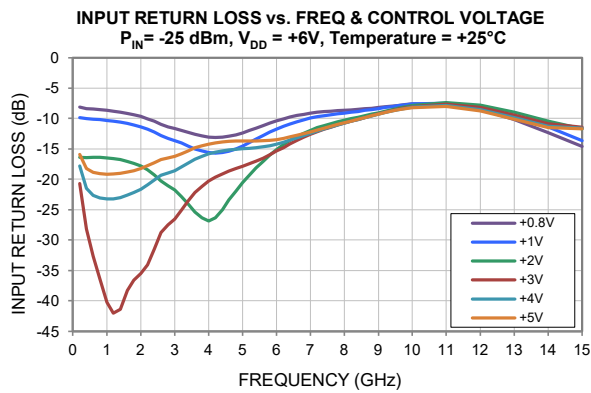
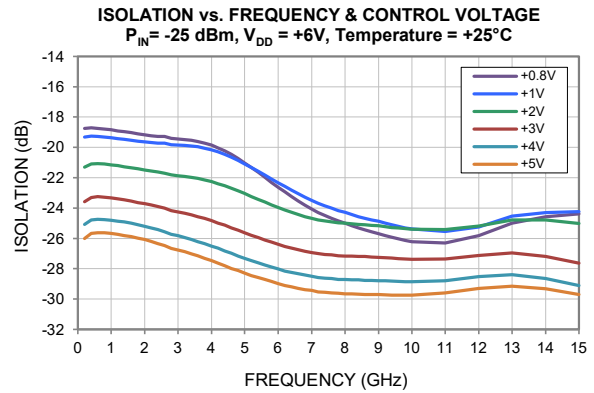
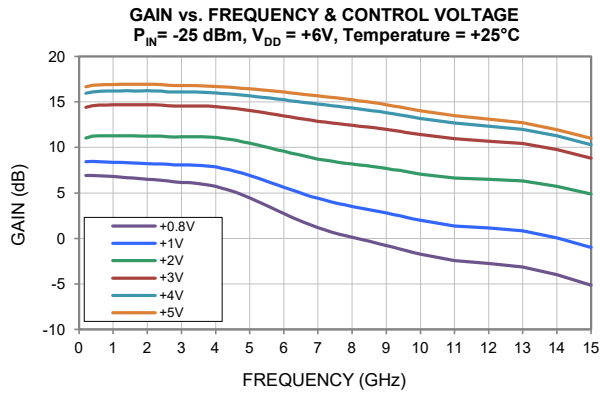

Typical Performance Curves

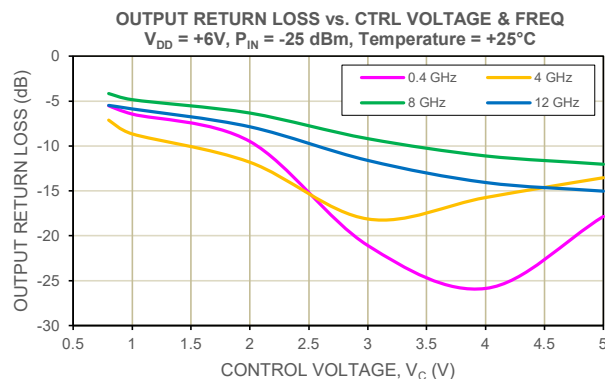
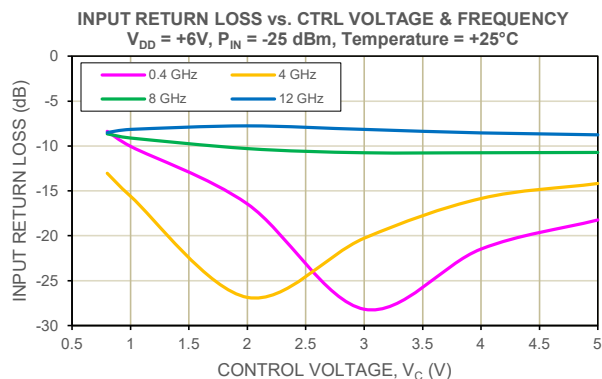
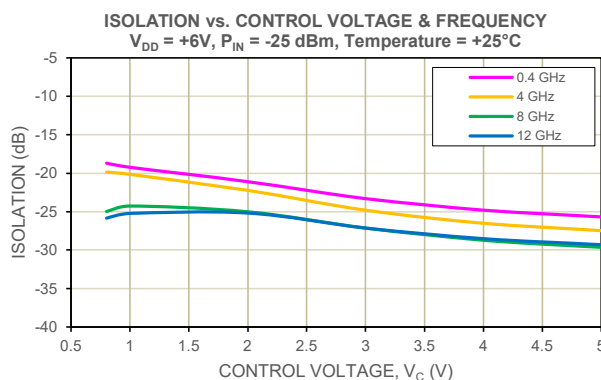
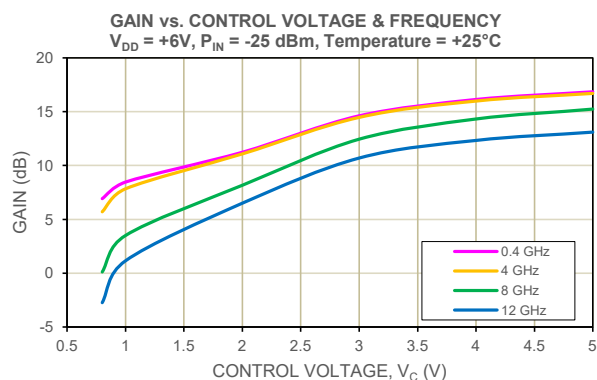
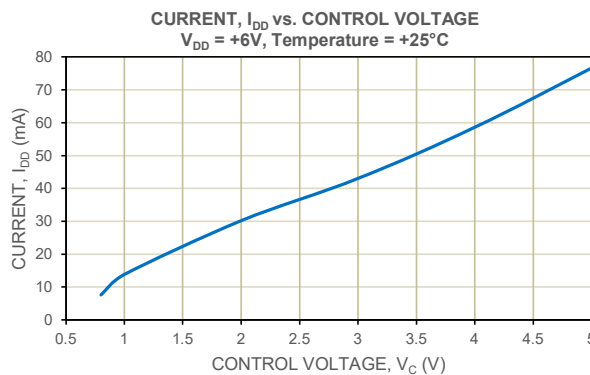
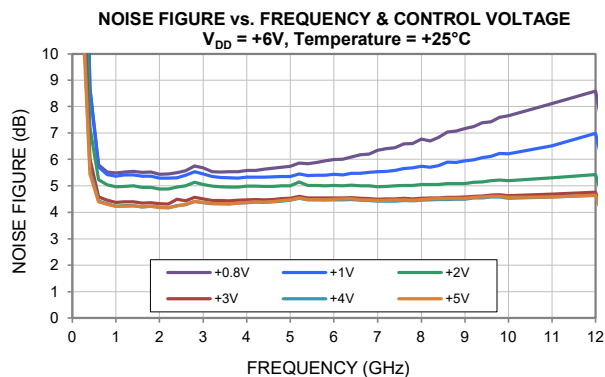

Typical Performance Curves

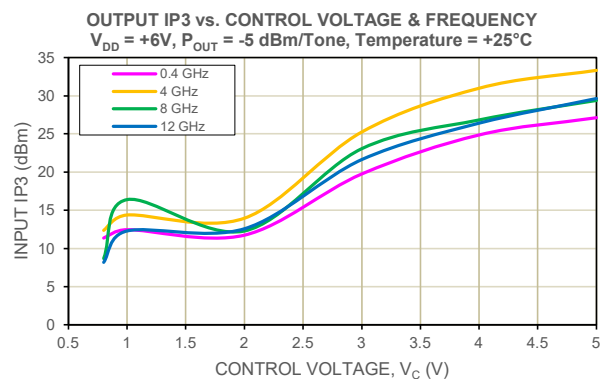
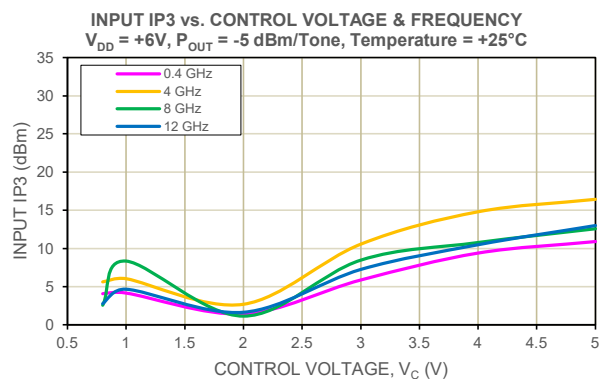
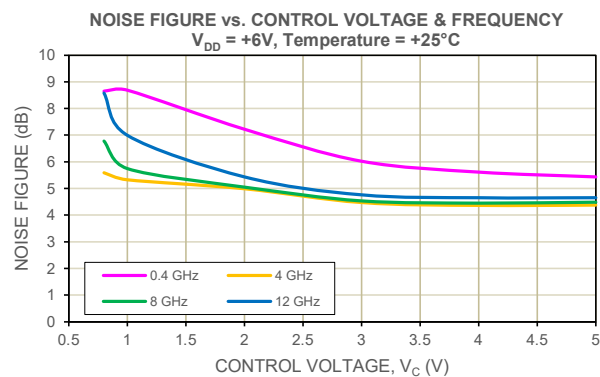
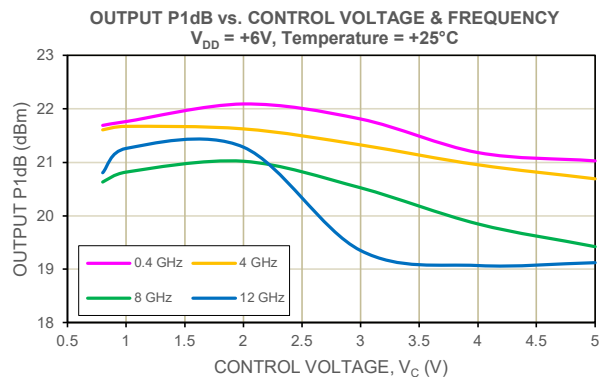

Typical Performance Curves

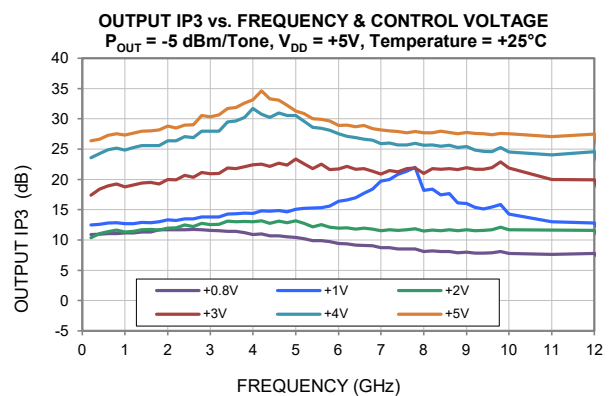
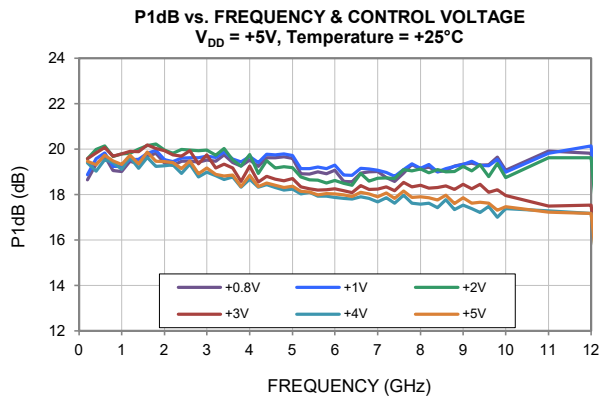
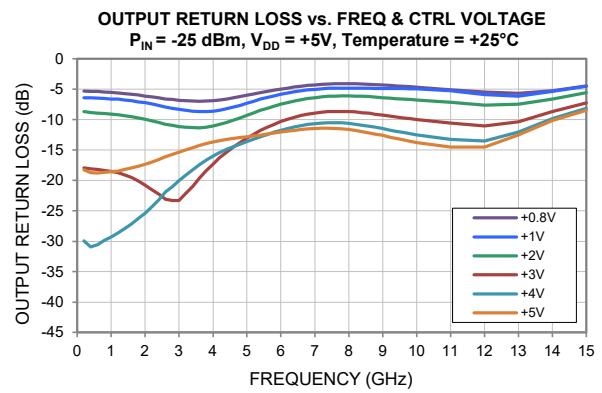
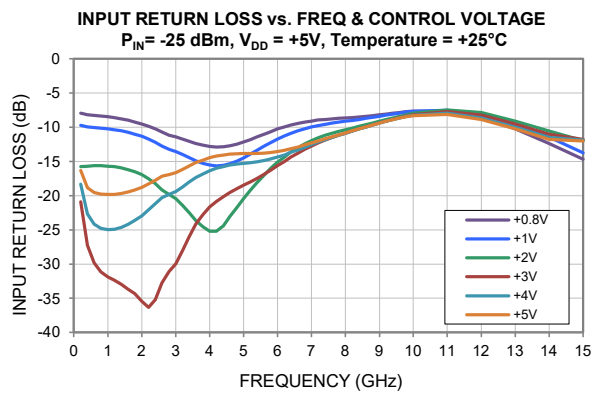
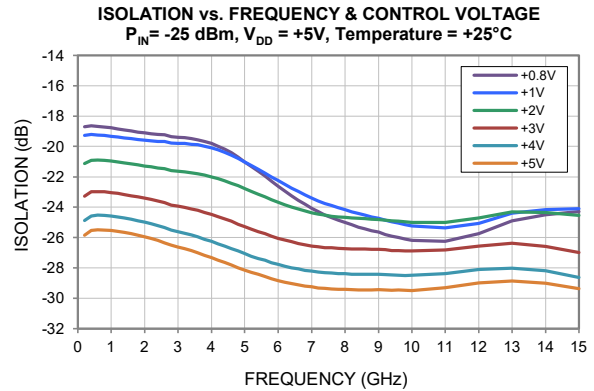
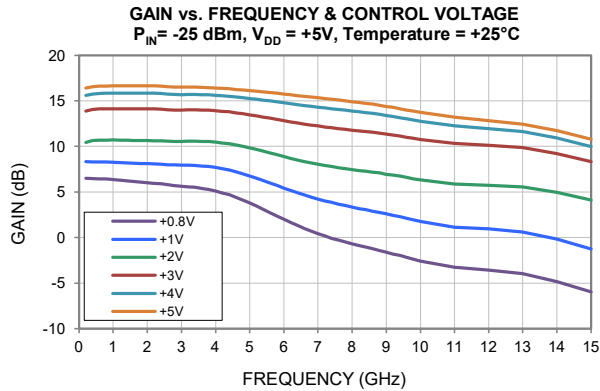

Typical Performance Curves

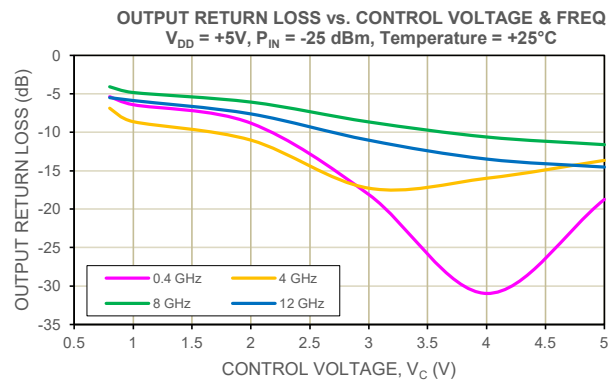
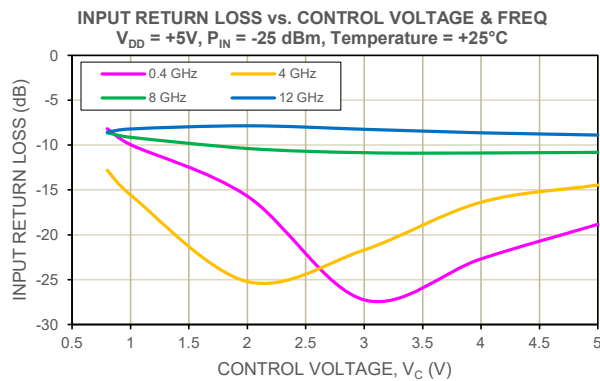
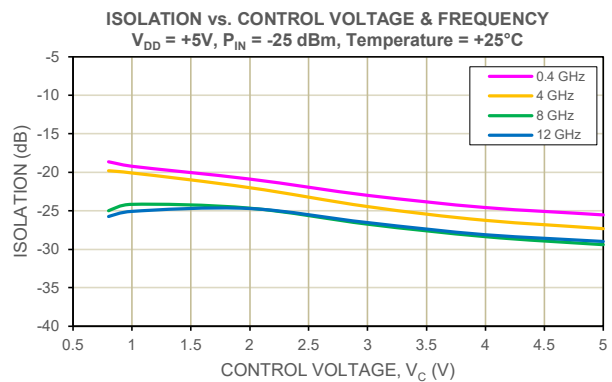
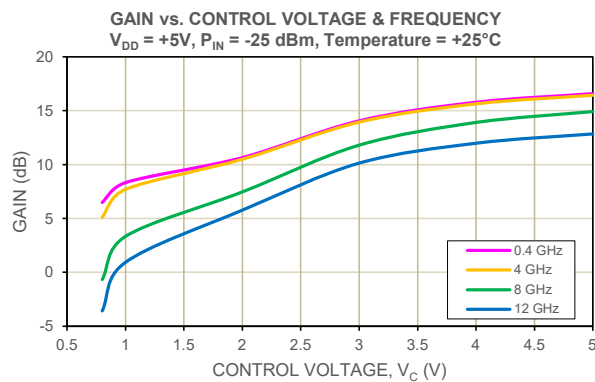
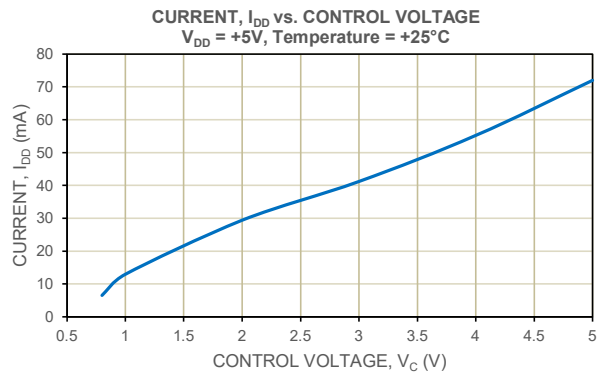
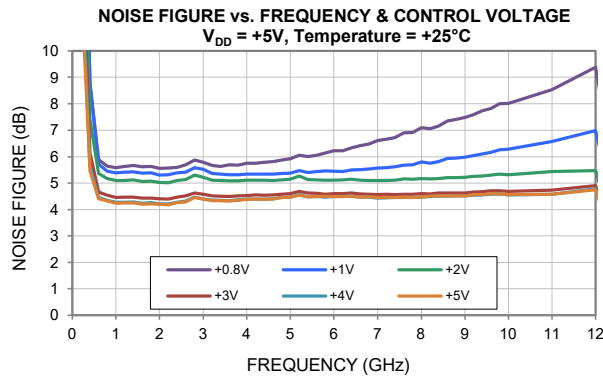

Typical Performance Curves

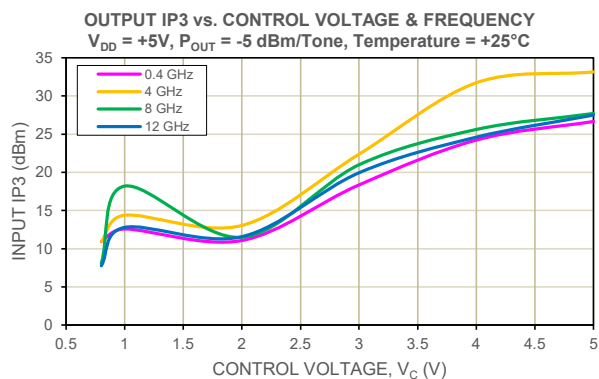
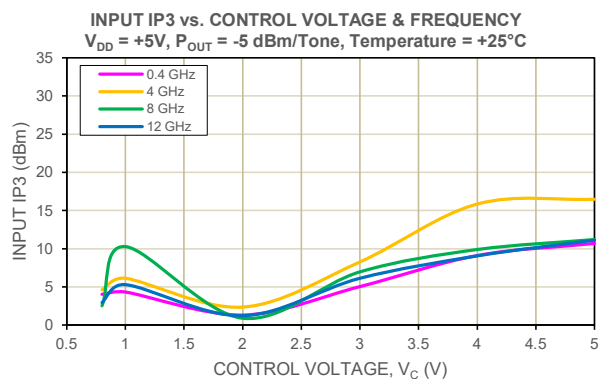
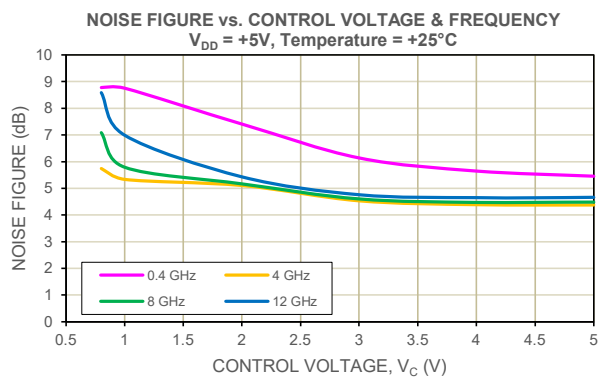
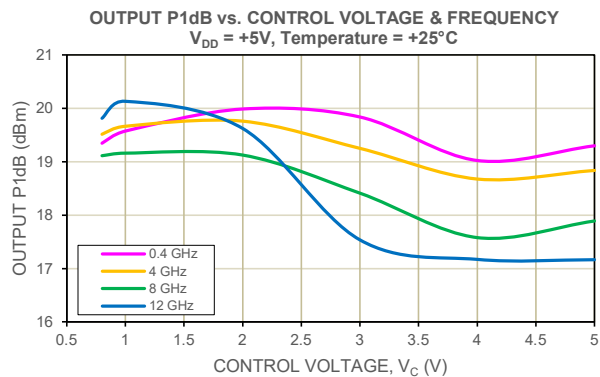

All Mini-Circuits products are manufactured under exacting quality assurance and control standards, and are capable of meeting published specifications after being subjected to any or all of the following physical and environmental test.

Specification	Test/Inspection Condition	Reference/Spec
Operating Temperature	-40° to 85° C or -40° to 105° C or -55° to 105° C or -45° to 105° C Ambient Environment	Refer to Individual Model Data Sheet
Storage Environment (Die)	-65° to 150°C	Individual Model Data Sheet
Storage Environment(Packaging)	-40° to 70°C and 40 to 60% humidity (In Factory Shipped Package)	