



LOW NOISE, HIGH IP3

Monolithic Amplifier

PSA-0012+

Mini-Circuits

50Ω 0.05 to 6 GHz

THE BIG DEAL

- Ideal IF Amplifier
- Low Noise Figure, 2.4 dB typ. at 1 GHz
- High IP3, up to 34 dBm typ. at 1 GHz
- Output Power at 1dB comp., up to +22 dBm typ.
- Gain, 16 dB typ. at 1 GHz
- Micro-miniature size SOT-363 package
- High Output Power
- Wide band
- May be used as replacement for M/A COM MAALSS0012^{a,b}



Generic photo used for illustration purposes only

CASE STYLE: CA1389

+RoHS Compliant

The +Suffix identifies RoHS Compliance. See our web site for RoHS Compliance methodologies and qualifications

APPLICATIONS

- Cellular
- ISM
- GSM
- WCDMA
- LTE
- WiMax
- WLAN
- UNII and HIPERLAN

PRODUCT OVERVIEW

The PSA-0012+ is an advanced wide band, high dynamic range, low noise, high IP3, high output power, monolithic amplifier. Manufactured using E-PHEMT* technology enables it to work with a single positive supply voltage.

KEY FEATURES

Feature	Advantages
Ideal Combined Performance Low Noise: 2.3 dB High IP3: +35 dBm High P1dB: +22 dBm Low Gain: 15dB	The PSA-0012+ design is optimized for use in critical IF Amplifier applications having an ideal combination of Low Gain, Low Noise, and High Output Power.
Wide band operation 50 MHz to 6000 MHz	Operating over a broad frequency range, the PSA-0012+ covers a wide range of typical IF bands making this amplifier ideal for use in a variety of applications.
Excellent Return Loss Input: 12 dB up to 4 GHz Output: 15 dB up to 5 GHz	With 12 dB input and 15 dB output return loss, the PSA-0012+ can be integrated into critical circuits with confidence that VSWR interactions with input and output components will have minimum affect on performance.
May be a replacement for MAALSS0012 ^{a,b}	The PSA-0012+ is pin-for-pin compatible with the M/A-Com IF Amplifier and provides comparable performance making it an ideal replacement.

* Enhancement mode pseudomorphic High Electron Mobility Transistor.

A. Suitability for model replacement within a particular system must be determined by and is solely the responsibility of the customer based on, among other things, electrical performance criteria, stimulus conditions, application, compatibility with other components and environmental conditions and stresses.

B. The M/A COM part number is used for identification and comparison purposes only.

REV. B
ECO-011279
PSA-0012+
NY-MCL
230713





LOW NOISE, HIGH IP3

Monolithic Amplifier

PSA-0012+

ELECTRICAL SPECIFICATIONS⁽¹⁾ AT 25°C, ZO=50Ω

Parameter	Condition (GHz)	Min.	Typ.	Max.	Units
Frequency Range		0.05		6.0	GHz
at DC Volts (Vd)			5.0		V
DC Current (Id)		60	74	100	mA
Noise Figure	0.05		2.9	—	dB
	0.5		2.3	—	
	1.0		2.3	—	
	2.0		2.4	3.0	
	3.0		2.5	—	
	4.0		2.8	—	
	5.0		3.2	—	
Gain	0.05	—	18.2	—	dB
	0.5	—	16.4	—	
	1.0	14.1	15.7	17.3	
	2.0	—	14.2	—	
	3.0	—	12.9	—	
	4.0	—	11.8	—	
	5.0	—	10.6	—	
Input Return Loss	0.05-0.5		11		dB
	0.5-4.0		12		
	4.0-6.0		9		
Output Return Loss	0.05-0.2		12		dB
	0.2-5		15		
	5-6		11		
Output IP3	0.05		31.7		dBm
	0.5		33.8		
	1.0		33.9		
	2.0		35.0		
	3.0		35.1		
	4.0		35.8		
	5.0		35.4		
6.0		35.1			
Output Power @1dB compression ⁽²⁾	0.05		21.7		dBm
	0.5		21.8		
	1.0		21.8		
	2.0		22.0		
	3.0		22.1		
	4.0		22.1		
	5.0		21.9		
6.0		21.2			
Thermal Resistance			137		°C/W





LOW NOISE, HIGH IP3

Monolithic Amplifier

PSA-0012+

MAXIMUM RATINGS⁽³⁾

Parameter	Ratings
Operating Temperature ⁽⁴⁾	-40°C to 85°C
Storage Temperature	-65°C to 150°C
Junction Temperature	160°C
DC Voltage (Pin 6)	6
Device Current (Pin 6)	110 mA
Power Dissipation	550 mW
Input Power (CW)	0.05-3GHz 14dBm 3-6GHz 19dBm

- (1) Measured on Mini-Circuits Characterization test board TB-539+ See Characterization Test Circuit (Fig. 1)
- (2) Current increases at P1dB
- (3) Permanent damage may occur if any of these limits are exceeded. These ratings are not intended for continuous normal operation.
- (4) Defined with reference to ground lead temperature.
- (5) Termination, 50 ohms

SIMPLIFIED SCHEMATIC AND PIN DESCRIPTION

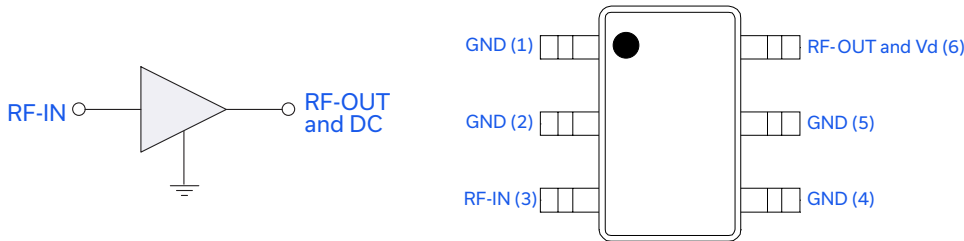

Function	Pin Number	Description (See Application Circuit, Fig. 2)
RF-IN	3	RF input pin (connect to RF-IN via DC blocking cap)
RF-OUT & Vd	6	RF output pin (connected to RF-out via blocking cap C2 and supply voltage Vd via RF Choke L1)
GND	1,2,4,5	Connections to ground





CHARACTERIZATION TEST CIRCUIT

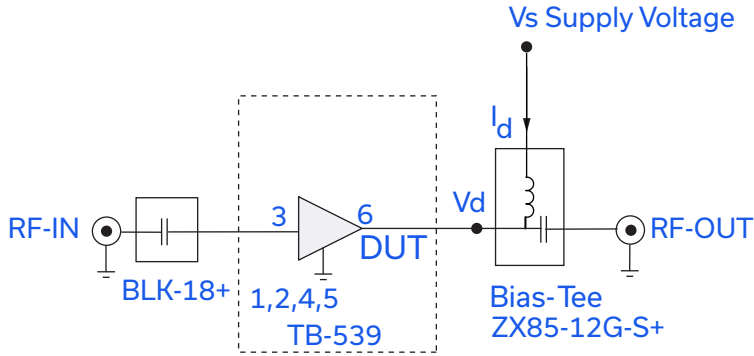

Fig 1. Block Diagram of Test Circuit used for characterization. (DUT soldered on Mini-Circuits Test Board TB-539+) Gain, Return loss, Output power at 1dB compression (P1 dB), Output IP3 (OIP3) and Noise Figure measured using Agilent's N5242A PNA-X microwave network analyzer.

Conditions:

1. Gain: Pin = -25dBm
2. Output IP3 (OIP3): Two tones, spaced 1 MHz apart, 5 dBm/ tone at output.
3. Vs adjusted for 5V at device (Vd), compensating loss of bias tee.

RECOMMENDED APPLICATION CIRCUIT

(refer to evaluation board for PCB Layout and component values)

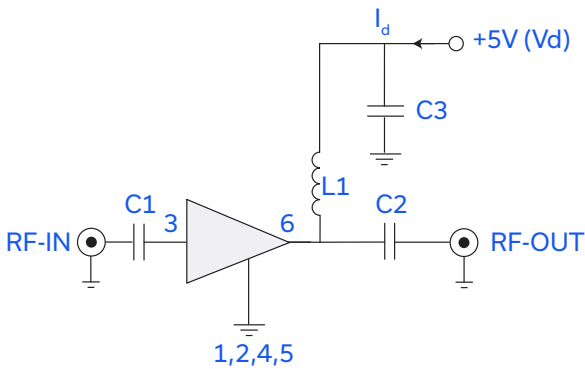
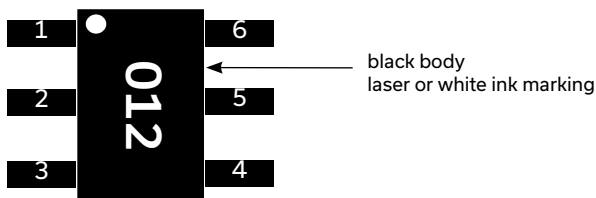

Fig 2. Recommended Application Circuit
Note: Resistance of L1, 0.1-0.2Ω typically

PRODUCT MARKING



Marking may contain other features or characters for internal lot control



ADDITIONAL DETAILED TECHNICAL INFORMATION IS AVAILABLE ON OUR DASH BOARD. TO ACCESS [CLICK HERE](#)

Performance Data	Data Table Swept Graphs S-Parameter (S2P Files) Data Set (.zip file)
Case Style	CA1389 Plastic molded SOT-363 package, lead finish: matte tin
Tape & Reel Standard quantities available on reel	F101 Standard quantities available on reel: 7" reels with 20, 50, 100, 200, 500, 1K, or 2K devices.
Suggested Layout for PCB Design	PL-316
Evaluation Board	TB-541+
Environmental Ratings	ENV08T2

ESD RATING

Human Body Model (HBM): Class 0 (<250V) in accordance with ANSI/ESD STM 5.1 - 2001; passes 150V

Machine Model (MM): Class M1 (<100V) in accordance with ANSI/ESD STM5.2-1999; passes 25V

MSL RATING

Moisture Sensitivity: MSL1 in accordance with IPC/JEDEC J-STD-020D

MSL TEST FLOW CHART

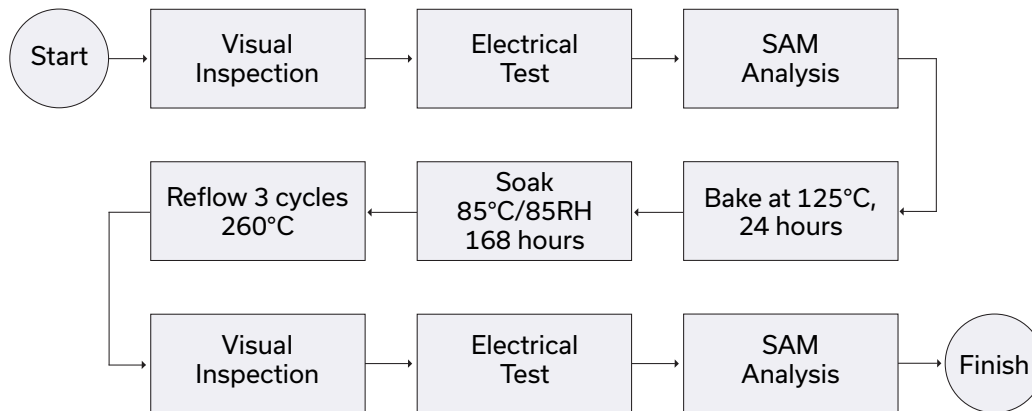

- NOTES**
- A. Performance and quality attributes and conditions not expressly stated in this specification document are intended to be excluded and do not form a part of this specification document.
 - B. Electrical specifications and performance data contained in this specification document are based on Mini-Circuit's applicable established test performance criteria and measurement instructions.
 - C. The parts covered by this specification document are subject to Mini-Circuits standard limited warranty and terms and conditions (collectively, "Standard Terms"); Purchasers of this part are entitled to the rights and benefits contained therein. For a full statement of the standard. Terms and the exclusive rights and remedies thereunder, please visit Mini-Circuits' website at www.minicircuits.com/MCLStore/terms.jsp

Typical Performance Data

NOTE: Use PDF Bookmarks to view DATA at required conditions

Definitions:

Input Return Loss = -S11 (dB)

Gain(Power Gain) = S21 (dB)

Reverse Isolation = -S12 (dB)

Output Return Loss = -S22 (dB)

TEST CONDITIONS: Vd = 5.00V, Id=72.88 mA @ Temperature = +25degC

FREQ	Gain	Isolation	Input Return Loss	Output Return Loss	Stability		IP-3 Output	1dB Comp. Output (1)	Noise Figure
					K	Measure			
(MHz)	(dB)	(dB)	(dB)	(dB)	K	Measure	(dBm)	(dBm)	(dB)
50.0	18.55	27.77	9.05	9.35	1.41	0.79	31.29	21.49	2.88
100.0	17.64	24.51	10.38	11.34	1.19	0.77	31.86	21.69	2.43
200.0	16.94	23.31	12.31	13.72	1.19	0.77	32.74	21.62	2.28
300.0	16.60	22.86	13.27	15.04	1.20	0.77	33.23	21.51	2.31
500.0	16.27	22.44	13.76	15.94	1.20	0.77	33.66	21.65	2.33
600.0	16.15	22.33	13.73	16.09	1.19	0.78	33.39	21.63	2.30
800.0	15.91	22.02	13.45	15.91	1.18	0.78	33.87	21.66	2.38
1000.0	15.65	21.77	13.03	15.51	1.17	0.79	34.05	21.65	2.39
1200.0	15.37	21.41	12.65	15.15	1.15	0.80	33.49	21.78	2.41
1400.0	15.09	21.10	12.23	14.87	1.13	0.80	33.80	21.84	2.45
1600.0	14.79	20.75	11.92	14.59	1.12	0.81	33.58	21.65	2.46
1700.0	14.64	20.59	11.81	14.47	1.11	0.81	34.00	21.80	2.43
1900.0	14.33	20.20	11.56	14.30	1.09	0.81	33.65	21.73	2.44
2100.0	14.03	19.88	11.39	14.16	1.09	0.81	34.27	21.82	2.46
2300.0	13.75	19.49	11.33	14.07	1.08	0.81	34.34	21.81	2.47
2500.0	13.46	19.17	11.32	14.03	1.07	0.81	34.38	21.80	2.46
2700.0	13.20	18.79	11.34	14.05	1.06	0.80	34.38	21.89	2.60
2900.0	12.94	18.46	11.43	14.17	1.06	0.80	34.55	21.84	2.60
3000.0	12.83	18.26	11.47	14.18	1.06	0.79	34.33	21.92	2.56
3200.0	12.59	17.89	11.60	14.35	1.05	0.79	34.75	21.92	2.62
3400.0	12.36	17.55	11.81	14.67	1.05	0.78	34.62	21.95	2.58
3600.0	12.07	17.30	12.21	15.28	1.06	0.77	34.82	22.01	2.76
3800.0	11.93	16.89	12.12	15.15	1.04	0.76	34.82	21.96	2.76
4000.0	11.70	16.52	12.10	15.47	1.04	0.75	35.22	22.00	2.80
4100.0	11.60	16.37	12.13	15.56	1.04	0.74	35.50	21.91	2.81
4300.0	11.38	16.08	11.92	15.64	1.04	0.74	35.65	21.99	2.86
4500.0	11.16	15.82	11.60	15.56	1.04	0.73	35.41	21.83	3.02
4700.0	10.96	15.51	11.04	14.87	1.03	0.72	35.59	22.02	2.99
4900.0	10.71	15.26	10.37	14.11	1.02	0.72	35.32	21.84	3.08
5100.0	10.44	15.06	9.62	13.27	1.01	0.71	35.13	21.68	3.16
5300.0	10.17	14.89	8.96	12.45	1.01	0.71	35.47	21.55	3.26
5400.0	10.03	14.80	8.59	12.00	1.01	0.71	35.44	21.82	3.29
5600.0	9.73	14.64	7.89	11.08	1.00	0.71	35.62	21.51	3.32
5800.0	9.41	14.52	7.25	10.20	0.99	0.70	35.41	21.24	3.41
6000.0	9.12	14.40	6.63	9.45	0.98	0.70	34.96	21.12	3.45
6200.0	8.80	14.31	6.13	8.77	0.97	0.70	34.73	21.15	3.53
6400.0	8.47	14.21	5.68	8.16	0.97	0.70	34.55	20.93	3.53
6600.0	8.13	14.15	5.20	7.61	0.96	0.70	34.10	20.97	3.71
6800.0	7.80	14.10	4.83	7.11	0.95	0.69	34.48	20.87	3.85
7000.0	7.45	14.06	4.49	6.63	0.94	0.69	34.14	20.51	4.29

(1) Current increases at P1dB



Typical Performance Data

Definitions:

Input Return Loss = -S11 (dB)

Gain(Power Gain) = S21 (dB)

Reverse Isolation = -S12 (dB)

Output Return Loss = -S22 (dB)

TEST CONDITIONS: Vd = 5V, Id=73.35 mA @ Temperature = -45degC

FREQ	Gain	Isolation	Input Return Loss	Output Return Loss	Stability		IP-3 Output	1dB Comp. Output (1)	Noise Figure
					K	Measure			
(MHz)	(dB)	(dB)	(dB)	(dB)	K	Measure	(dBm)	(dBm)	(dB)
50.0	18.34	25.86	9.96	10.03	1.27	0.73	30.09	21.61	2.38
100.0	17.50	24.35	11.44	12.33	1.21	0.78	31.05	21.76	2.04
200.0	16.75	22.96	13.46	14.71	1.19	0.77	32.35	21.66	1.89
300.0	16.37	22.49	14.80	16.40	1.20	0.77	33.07	21.53	1.93
500.0	16.02	22.07	15.74	17.93	1.20	0.77	33.59	21.64	1.97
600.0	15.91	21.92	15.71	18.14	1.20	0.77	33.23	21.63	1.94
800.0	15.69	21.68	15.40	17.97	1.19	0.77	33.93	21.64	2.01
1000.0	15.46	21.40	14.88	17.57	1.18	0.78	34.10	21.66	1.99
1200.0	15.22	21.10	14.38	17.18	1.16	0.78	33.65	21.73	2.02
1400.0	14.97	20.82	13.84	16.78	1.15	0.78	33.87	21.81	2.06
1600.0	14.71	20.51	13.43	16.38	1.14	0.79	33.59	21.65	2.06
1700.0	14.57	20.35	13.24	16.27	1.13	0.79	34.02	21.75	2.04
1900.0	14.30	20.03	12.92	15.96	1.12	0.79	33.61	21.70	1.99
2100.0	14.03	19.70	12.70	15.76	1.11	0.79	34.15	21.77	2.02
2300.0	13.77	19.36	12.60	15.59	1.10	0.79	34.24	21.75	2.01
2500.0	13.51	19.00	12.52	15.43	1.09	0.78	34.16	21.76	2.04
2700.0	13.27	18.65	12.48	15.43	1.08	0.78	34.22	21.83	2.10
2900.0	13.03	18.33	12.53	15.55	1.08	0.77	34.24	21.80	2.15
3000.0	12.92	18.13	12.54	15.51	1.07	0.77	34.13	21.88	2.10
3200.0	12.71	17.79	12.62	15.57	1.07	0.76	34.54	21.90	2.07
3400.0	12.49	17.45	12.85	15.81	1.06	0.75	34.42	21.93	2.10
3600.0	12.22	17.15	13.17	16.43	1.07	0.74	34.57	21.99	2.09
3800.0	12.09	16.76	13.06	16.40	1.05	0.72	34.61	21.99	2.18
4000.0	11.87	16.45	13.08	16.63	1.05	0.71	34.86	22.02	2.11
4100.0	11.77	16.27	13.01	16.63	1.05	0.71	35.16	21.96	2.22
4300.0	11.57	15.99	12.75	16.64	1.05	0.70	35.16	22.04	2.30
4500.0	11.37	15.71	12.31	16.40	1.04	0.69	34.83	21.93	2.31
4700.0	11.16	15.44	11.64	15.52	1.03	0.68	34.97	22.05	2.43
4900.0	10.93	15.17	10.85	14.53	1.02	0.67	34.85	21.93	2.43
5100.0	10.66	14.97	10.05	13.48	1.02	0.67	34.47	21.76	2.49
5300.0	10.39	14.80	9.28	12.52	1.02	0.66	34.64	21.65	2.56
5400.0	10.26	14.71	8.87	12.06	1.01	0.66	34.68	21.90	2.65
5600.0	9.96	14.55	8.07	11.05	1.01	0.66	34.28	21.61	2.63
5800.0	9.66	14.44	7.45	10.21	1.00	0.65	34.10	21.34	2.75
6000.0	9.38	14.31	6.82	9.44	0.99	0.65	33.65	21.24	2.82
6200.0	9.08	14.22	6.29	8.76	0.98	0.65	33.55	21.26	2.90
6400.0	8.76	14.10	5.80	8.20	0.98	0.64	33.43	21.05	2.90
6600.0	8.44	14.04	5.33	7.59	0.97	0.64	33.22	21.07	2.94
6800.0	8.14	13.99	4.95	7.11	0.96	0.63	33.34	20.94	3.09
7000.0	7.85	13.90	4.61	6.67	0.95	0.62	32.85	20.62	3.28

(1) Current increases at P1dB

Typical Performance Data

Definitions:

Input Return Loss = -S11 (dB)

Gain(Power Gain) = S21 (dB)

Reverse Isolation = -S12 (dB)

Output Return Loss = -S22 (dB)

TEST CONDITIONS: Vd = 5V, Id=73.32 mA @ Temperature = +85degC

FREQ	Gain	Isolation	Input Return Loss	Output Return Loss	Stability		IP-3 Output	1dB Comp. Output (1)	Noise Figure
					K	Measure			
(MHz)	(dB)	(dB)	(dB)	(dB)	K	Measure	(dBm)	(dBm)	(dB)
50.0	18.63	26.53	8.02	8.27	1.24	0.70	32.37	21.54	3.09
100.0	17.73	24.66	9.60	10.67	1.18	0.76	32.52	21.65	2.72
200.0	17.08	23.53	11.35	12.88	1.19	0.77	33.47	21.54	2.54
300.0	16.77	23.13	12.13	13.96	1.19	0.77	33.94	21.42	2.58
500.0	16.44	22.78	12.32	14.44	1.19	0.78	34.39	21.57	2.59
600.0	16.31	22.64	12.25	14.49	1.19	0.78	33.95	21.56	2.56
800.0	16.05	22.34	12.02	14.38	1.17	0.79	34.32	21.59	2.64
1000.0	15.75	21.98	11.68	14.00	1.15	0.80	34.52	21.57	2.65
1200.0	15.45	21.64	11.38	13.66	1.13	0.81	33.88	21.73	2.68
1400.0	15.13	21.24	11.06	13.52	1.11	0.82	34.40	21.80	2.71
1600.0	14.81	20.88	10.81	13.31	1.09	0.82	34.14	21.60	2.73
1700.0	14.65	20.71	10.73	13.23	1.08	0.83	34.59	21.77	2.76
1900.0	14.32	20.34	10.58	13.13	1.07	0.83	34.05	21.70	2.74
2100.0	14.00	19.97	10.45	13.12	1.06	0.83	34.85	21.78	2.77
2300.0	13.69	19.60	10.44	13.06	1.06	0.83	34.91	21.80	2.79
2500.0	13.40	19.24	10.50	13.08	1.05	0.83	34.86	21.78	2.82
2700.0	13.12	18.87	10.57	13.18	1.05	0.82	34.94	21.85	2.92
2900.0	12.84	18.47	10.72	13.34	1.04	0.82	34.99	21.81	2.94
3000.0	12.72	18.31	10.79	13.42	1.04	0.81	34.88	21.87	2.94
3200.0	12.47	17.93	10.91	13.71	1.04	0.81	35.25	21.89	2.96
3400.0	12.22	17.60	11.14	14.14	1.04	0.80	35.16	21.89	2.96
3600.0	11.96	17.32	11.54	14.44	1.05	0.79	35.22	21.96	3.07
3800.0	11.76	16.92	11.54	14.59	1.04	0.78	35.42	21.86	3.09
4000.0	11.52	16.59	11.49	14.96	1.04	0.78	35.79	21.90	3.20
4100.0	11.40	16.47	11.52	15.11	1.04	0.78	36.34	21.79	3.14
4300.0	11.18	16.16	11.30	15.09	1.04	0.77	36.57	21.87	3.24
4500.0	10.94	15.91	10.99	15.00	1.04	0.77	36.19	21.68	3.49
4700.0	10.72	15.60	10.48	14.36	1.03	0.76	36.30	21.87	3.38
4900.0	10.46	15.36	9.89	13.66	1.02	0.75	36.27	21.73	3.55
5100.0	10.18	15.16	9.20	12.94	1.02	0.75	35.84	21.57	3.53
5300.0	9.91	14.98	8.62	12.16	1.01	0.75	36.35	21.42	3.79
5400.0	9.76	14.89	8.31	11.74	1.01	0.75	36.20	21.72	3.76
5600.0	9.47	14.72	7.67	10.89	1.00	0.75	36.39	21.41	3.80
5800.0	9.14	14.58	7.05	10.05	0.99	0.75	36.57	21.15	3.81
6000.0	8.83	14.48	6.47	9.32	0.98	0.75	36.02	21.03	3.98
6200.0	8.53	14.37	6.05	8.73	0.97	0.75	35.72	21.07	4.14
6400.0	8.20	14.28	5.63	8.17	0.96	0.74	35.53	20.86	4.14
6600.0	7.85	14.24	5.16	7.65	0.95	0.75	35.11	20.90	4.26
6800.0	7.50	14.18	4.81	7.14	0.94	0.74	35.30	20.81	4.40
7000.0	7.13	14.17	4.48	6.67	0.93	0.74	35.09	20.43	4.75

(1) Current increases at P1dB

Typical Performance Data

Definitions:

Input Return Loss = -S11 (dB)

Gain(Power Gain) = S21 (dB)

Reverse Isolation = -S12 (dB)

Output Return Loss = -S22 (dB)

TEST CONDITIONS: Vd = 5.00V, Id=72.88 mA @ Temperature = +25degC

FREQ	Gain	Isolation	Input Return Loss	Output Return Loss	Stability		IP-3 Output	1dB Comp. Output (1)	Noise Figure
					K	Measure			
(MHz)	(dB)	(dB)	(dB)	(dB)	K	Measure	(dBm)	(dBm)	(dB)
50.0	18.55	27.77	9.05	9.35	1.41	0.79	31.29	21.49	2.88
100.0	17.64	24.51	10.38	11.34	1.19	0.77	31.86	21.69	2.43
200.0	16.94	23.31	12.31	13.72	1.19	0.77	32.74	21.62	2.28
300.0	16.60	22.86	13.27	15.04	1.20	0.77	33.23	21.51	2.31
500.0	16.27	22.44	13.76	15.94	1.20	0.77	33.66	21.65	2.33
600.0	16.15	22.33	13.73	16.09	1.19	0.78	33.39	21.63	2.30
800.0	15.91	22.02	13.45	15.91	1.18	0.78	33.87	21.66	2.38
1000.0	15.65	21.77	13.03	15.51	1.17	0.79	34.05	21.65	2.39
1200.0	15.37	21.41	12.65	15.15	1.15	0.80	33.49	21.78	2.41
1400.0	15.09	21.10	12.23	14.87	1.13	0.80	33.80	21.84	2.45
1600.0	14.79	20.75	11.92	14.59	1.12	0.81	33.58	21.65	2.46
1700.0	14.64	20.59	11.81	14.47	1.11	0.81	34.00	21.80	2.43
1900.0	14.33	20.20	11.56	14.30	1.09	0.81	33.65	21.73	2.44
2100.0	14.03	19.88	11.39	14.16	1.09	0.81	34.27	21.82	2.46
2300.0	13.75	19.49	11.33	14.07	1.08	0.81	34.34	21.81	2.47
2500.0	13.46	19.17	11.32	14.03	1.07	0.81	34.38	21.80	2.46
2700.0	13.20	18.79	11.34	14.05	1.06	0.80	34.38	21.89	2.60
2900.0	12.94	18.46	11.43	14.17	1.06	0.80	34.55	21.84	2.60
3000.0	12.83	18.26	11.47	14.18	1.06	0.79	34.33	21.92	2.56
3200.0	12.59	17.89	11.60	14.35	1.05	0.79	34.75	21.92	2.62
3400.0	12.36	17.55	11.81	14.67	1.05	0.78	34.62	21.95	2.58
3600.0	12.07	17.30	12.21	15.28	1.06	0.77	34.82	22.01	2.76
3800.0	11.93	16.89	12.12	15.15	1.04	0.76	34.82	21.96	2.76
4000.0	11.70	16.52	12.10	15.47	1.04	0.75	35.22	22.00	2.80
4100.0	11.60	16.37	12.13	15.56	1.04	0.74	35.50	21.91	2.81
4300.0	11.38	16.08	11.92	15.64	1.04	0.74	35.65	21.99	2.86
4500.0	11.16	15.82	11.60	15.56	1.04	0.73	35.41	21.83	3.02
4700.0	10.96	15.51	11.04	14.87	1.03	0.72	35.59	22.02	2.99
4900.0	10.71	15.26	10.37	14.11	1.02	0.72	35.32	21.84	3.08
5100.0	10.44	15.06	9.62	13.27	1.01	0.71	35.13	21.68	3.16
5300.0	10.17	14.89	8.96	12.45	1.01	0.71	35.47	21.55	3.26
5400.0	10.03	14.80	8.59	12.00	1.01	0.71	35.44	21.82	3.29
5600.0	9.73	14.64	7.89	11.08	1.00	0.71	35.62	21.51	3.32
5800.0	9.41	14.52	7.25	10.20	0.99	0.70	35.41	21.24	3.41
6000.0	9.12	14.40	6.63	9.45	0.98	0.70	34.96	21.12	3.45
6200.0	8.80	14.31	6.13	8.77	0.97	0.70	34.73	21.15	3.53
6400.0	8.47	14.21	5.68	8.16	0.97	0.70	34.55	20.93	3.53
6600.0	8.13	14.15	5.20	7.61	0.96	0.70	34.10	20.97	3.71
6800.0	7.80	14.10	4.83	7.11	0.95	0.69	34.48	20.87	3.85
7000.0	7.45	14.06	4.49	6.63	0.94	0.69	34.14	20.51	4.29

(1) Current increases at P1dB

Typical Performance Data

Definitions:

Input Return Loss = -S11 (dB)

Gain(Power Gain) = S21 (dB)

Reverse Isolation = -S12 (dB)

Output Return Loss = -S22 (dB)

TEST CONDITIONS: Vd = 4.75V, Id=64.47mA @ Temperature = +25degC

FREQ	Gain	Isolation	Input Return Loss	Output Return Loss	Stability		IP-3 Output	1dB Comp. Output (1)	Noise Figure
					K	Measure			
(MHz)	(dB)	(dB)	(dB)	(dB)	K	Measure	(dBm)	(dBm)	(dB)
50.0	18.34	26.29	8.87	8.88	1.27	0.72	30.67	20.89	2.73
100.0	17.42	24.34	10.26	11.14	1.20	0.77	30.76	21.03	2.38
200.0	16.73	23.16	12.14	13.42	1.19	0.77	31.69	20.96	2.23
300.0	16.40	22.72	13.10	14.67	1.20	0.77	32.00	20.86	2.27
500.0	16.08	22.32	13.61	15.54	1.20	0.77	32.39	20.95	2.31
600.0	15.96	22.18	13.56	15.66	1.19	0.78	31.95	20.94	2.30
800.0	15.72	21.93	13.31	15.49	1.18	0.79	32.34	20.97	2.35
1000.0	15.46	21.60	12.91	15.12	1.16	0.79	32.45	20.99	2.37
1200.0	15.19	21.29	12.53	14.78	1.15	0.80	32.03	21.06	2.39
1400.0	14.91	20.98	12.12	14.52	1.13	0.81	32.22	21.14	2.44
1600.0	14.61	20.64	11.82	14.26	1.12	0.81	32.07	20.97	2.43
1700.0	14.46	20.48	11.70	14.14	1.11	0.81	32.55	21.08	2.40
1900.0	14.17	20.11	11.46	13.96	1.10	0.81	31.94	21.01	2.42
2100.0	13.87	19.75	11.29	13.86	1.08	0.82	32.63	21.09	2.43
2300.0	13.59	19.40	11.22	13.75	1.08	0.81	32.84	21.07	2.46
2500.0	13.31	19.05	11.21	13.72	1.07	0.81	32.72	21.09	2.45
2700.0	13.05	18.71	11.23	13.77	1.06	0.81	32.87	21.15	2.61
2900.0	12.80	18.39	11.31	13.88	1.06	0.80	33.00	21.11	2.55
3000.0	12.68	18.16	11.37	13.89	1.05	0.80	32.64	21.20	2.60
3200.0	12.45	17.80	11.48	14.07	1.05	0.79	33.16	21.22	2.59
3400.0	12.22	17.45	11.68	14.40	1.05	0.78	33.06	21.24	2.60
3600.0	11.94	17.23	12.09	14.99	1.06	0.78	33.24	21.30	2.69
3800.0	11.81	16.80	12.01	14.92	1.04	0.76	33.32	21.27	2.58
4000.0	11.58	16.46	12.00	15.22	1.04	0.75	33.93	21.31	2.76
4100.0	11.47	16.31	12.02	15.33	1.04	0.75	34.37	21.29	2.77
4300.0	11.27	16.02	11.84	15.42	1.04	0.74	34.67	21.33	2.78
4500.0	11.05	15.78	11.53	15.37	1.04	0.74	34.36	21.19	2.83
4700.0	10.84	15.48	10.98	14.76	1.03	0.73	34.51	21.33	2.99
4900.0	10.60	15.21	10.32	14.03	1.02	0.72	34.35	21.20	3.10
5100.0	10.33	15.01	9.60	13.23	1.01	0.72	34.07	21.07	3.11
5300.0	10.06	14.85	8.92	12.42	1.01	0.72	34.71	20.95	3.19
5400.0	9.92	14.76	8.56	11.99	1.01	0.72	34.59	21.21	3.23
5600.0	9.62	14.62	7.86	11.08	1.00	0.72	34.97	20.96	3.25
5800.0	9.31	14.47	7.23	10.21	0.99	0.71	35.18	20.68	3.25
6000.0	9.01	14.39	6.62	9.47	0.98	0.72	34.75	20.59	3.42
6200.0	8.70	14.29	6.12	8.79	0.97	0.71	34.30	20.62	3.52
6400.0	8.36	14.22	5.67	8.19	0.97	0.71	34.14	20.39	3.52
6600.0	8.03	14.15	5.20	7.64	0.96	0.71	33.71	20.42	3.65
6800.0	7.70	14.09	4.82	7.14	0.95	0.71	34.04	20.33	3.77
7000.0	7.35	14.08	4.48	6.65	0.94	0.70	33.78	20.02	4.00

(1) Current increases at P1dB

Typical Performance Data

Definitions:

Input Return Loss = -S11 (dB)

Gain(Power Gain) = S21 (dB)

Reverse Isolation = -S12 (dB)

Output Return Loss = -S22 (dB)

TEST CONDITIONS: Vd = 5.25V, Id=81.49mA @ Temperature = +25degC

FREQ	Gain	Isolation	Input Return Loss	Output Return Loss	Stability		IP-3 Output	1dB Comp. Output (1)	Noise Figure
					K	Measure			
(MHz)	(dB)	(dB)	(dB)	(dB)	K	Measure	(dBm)	(dBm)	(dB)
50.0	18.63	27.08	8.58	9.35	1.32	0.77	32.07	22.03	3.04
100.0	17.83	24.62	10.45	11.48	1.19	0.77	32.77	22.30	2.55
200.0	17.11	23.37	12.40	13.87	1.18	0.77	33.66	22.21	2.33
300.0	16.77	22.95	13.38	15.24	1.19	0.77	34.06	22.10	2.36
500.0	16.44	22.55	13.85	16.18	1.19	0.77	34.53	22.26	2.36
600.0	16.32	22.43	13.80	16.31	1.19	0.78	34.34	22.24	2.34
800.0	16.07	22.17	13.51	16.12	1.18	0.78	34.89	22.28	2.39
1000.0	15.80	21.87	13.08	15.72	1.16	0.79	34.97	22.26	2.40
1200.0	15.52	21.55	12.69	15.36	1.15	0.80	34.38	22.42	2.43
1400.0	15.23	21.21	12.28	15.08	1.13	0.80	35.02	22.47	2.47
1600.0	14.92	20.84	11.96	14.77	1.11	0.81	34.70	22.28	2.48
1700.0	14.77	20.70	11.86	14.65	1.11	0.81	35.07	22.47	2.46
1900.0	14.46	20.35	11.61	14.47	1.10	0.81	34.95	22.37	2.47
2100.0	14.16	19.97	11.42	14.36	1.09	0.81	35.34	22.47	2.48
2300.0	13.87	19.60	11.38	14.25	1.08	0.81	35.43	22.48	2.48
2500.0	13.58	19.26	11.38	14.20	1.07	0.81	35.33	22.47	2.49
2700.0	13.32	18.85	11.40	14.23	1.06	0.80	35.50	22.54	2.61
2900.0	13.05	18.51	11.49	14.33	1.06	0.80	35.58	22.52	2.65
3000.0	12.94	18.35	11.53	14.35	1.06	0.79	35.41	22.57	2.62
3200.0	12.70	17.97	11.64	14.51	1.05	0.78	35.61	22.60	2.62
3400.0	12.46	17.59	11.85	14.84	1.05	0.77	35.50	22.60	2.65
3600.0	12.17	17.35	12.26	15.43	1.06	0.77	35.81	22.66	2.69
3800.0	12.03	16.92	12.18	15.29	1.04	0.75	35.81	22.60	2.71
4000.0	11.80	16.58	12.14	15.60	1.04	0.75	36.09	22.61	2.88
4100.0	11.69	16.43	12.17	15.71	1.04	0.74	36.01	22.53	2.83
4300.0	11.47	16.14	11.97	15.76	1.04	0.73	36.00	22.61	2.93
4500.0	11.25	15.86	11.64	15.66	1.04	0.73	36.00	22.41	3.01
4700.0	11.04	15.56	11.07	14.96	1.03	0.72	35.77	22.57	3.01
4900.0	10.80	15.31	10.40	14.16	1.02	0.71	35.86	22.44	3.11
5100.0	10.52	15.10	9.65	13.30	1.01	0.71	35.44	22.24	3.17
5300.0	10.25	14.91	8.97	12.48	1.01	0.71	35.64	22.09	3.26
5400.0	10.11	14.83	8.61	12.03	1.01	0.70	35.86	22.39	3.35
5600.0	9.81	14.65	7.89	11.09	1.00	0.70	35.33	22.06	3.36
5800.0	9.49	14.53	7.25	10.21	0.99	0.70	35.36	21.75	3.50
6000.0	9.20	14.42	6.64	9.47	0.98	0.70	34.78	21.63	3.53
6200.0	8.88	14.32	6.14	8.77	0.97	0.69	34.63	21.67	3.62
6400.0	8.55	14.22	5.68	8.16	0.97	0.69	34.64	21.43	3.62
6600.0	8.21	14.15	5.20	7.61	0.96	0.69	34.25	21.47	3.84
6800.0	7.88	14.10	4.83	7.09	0.95	0.69	34.49	21.37	3.97
7000.0	7.53	14.08	4.48	6.61	0.94	0.68	34.01	20.99	4.34

(1) Current increases at P1dB

Typical Performance Curves

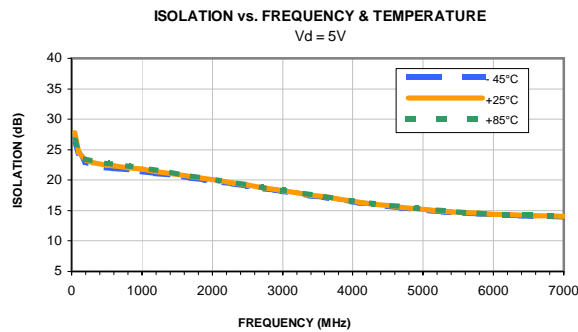
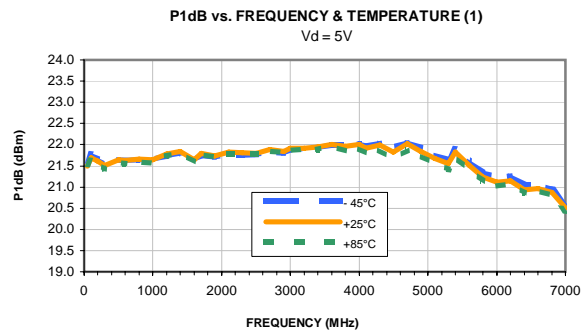
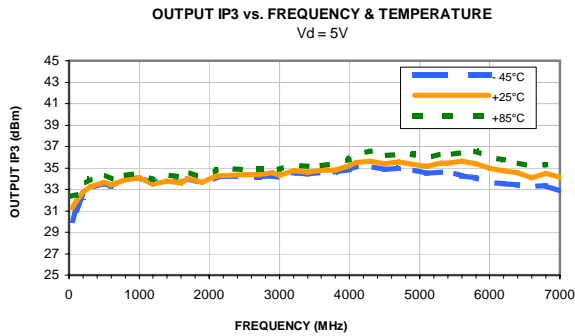
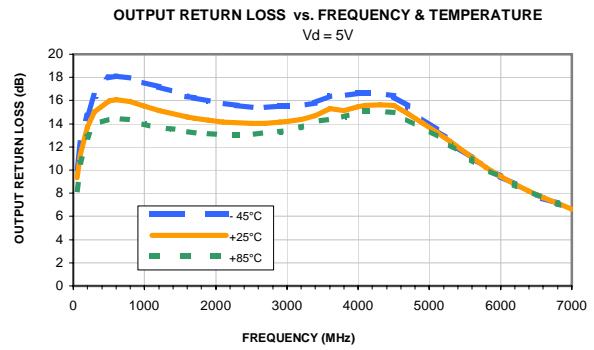
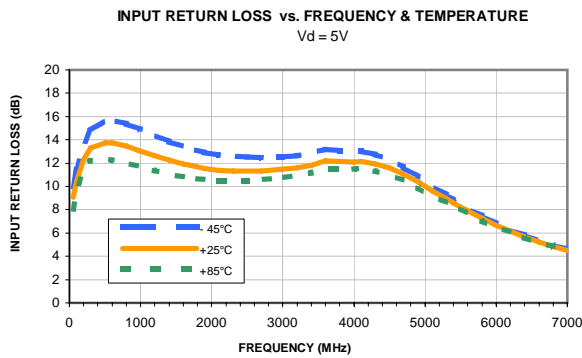
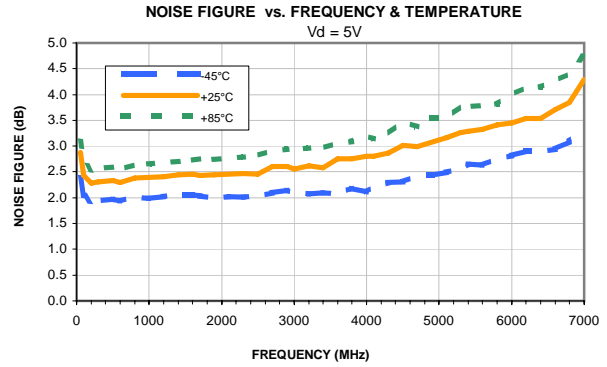
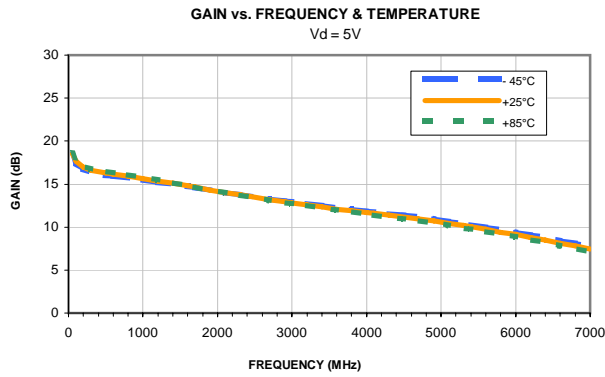

(1) Current increases at P1dB

Typical Performance Curves

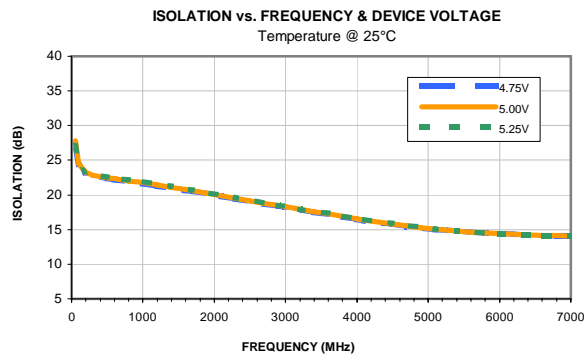
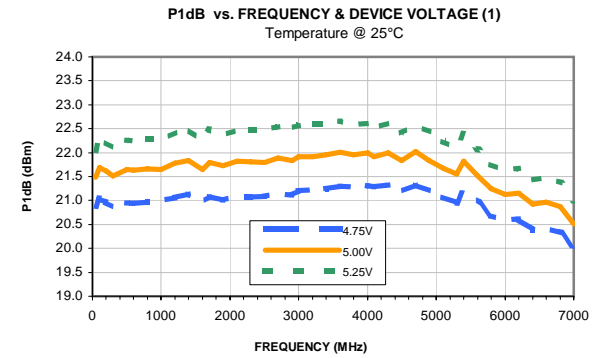
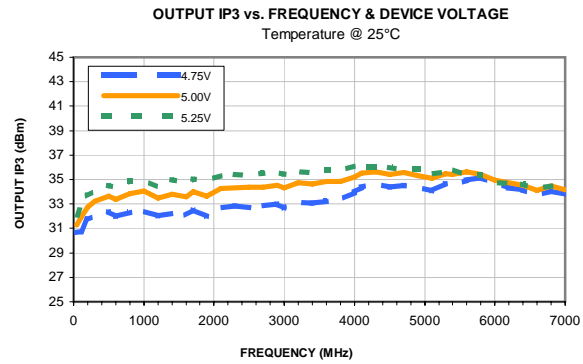
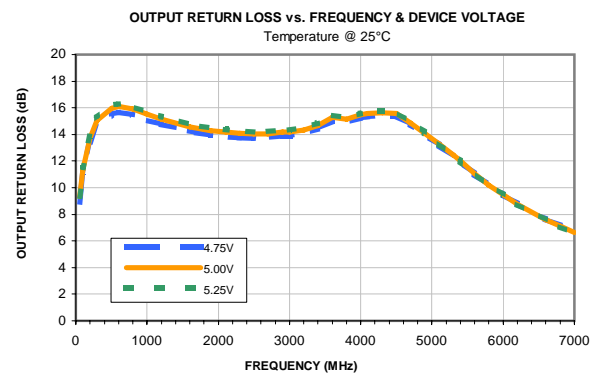
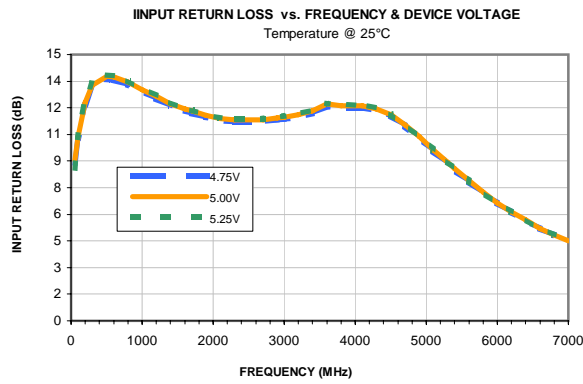
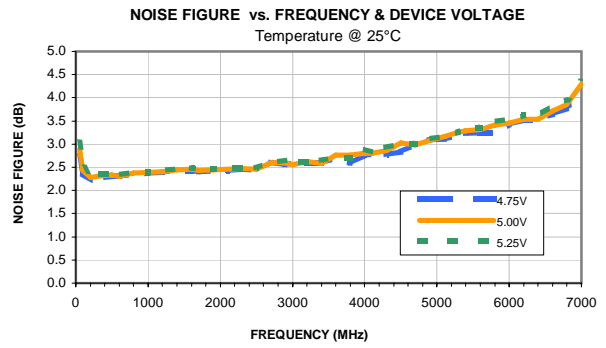
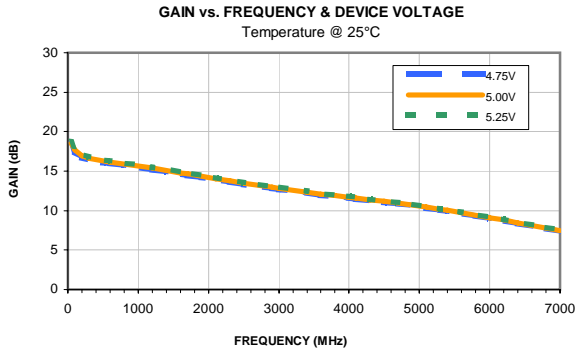

(1) Current increases at P1dB

Outline Dimensions

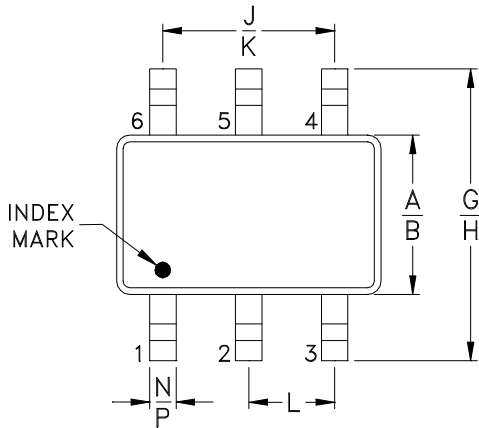

PCB Land Pattern

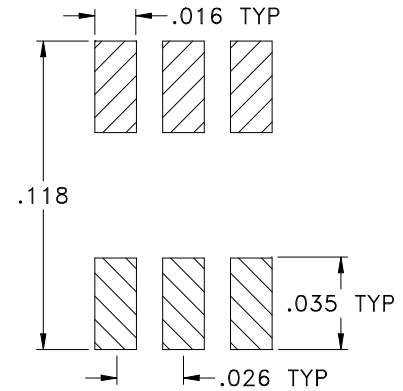

Suggested Layout,
Tolerance to be within $\pm .002$

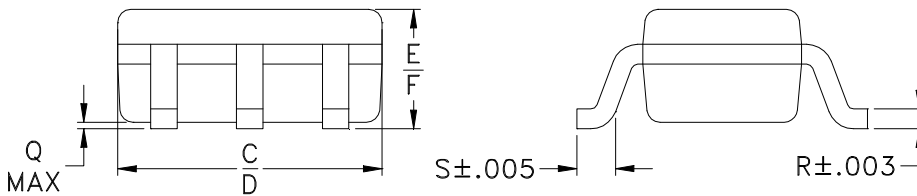

CASE #	A	B	C	D	E	F	G	H	J	K
CA1389	.045 (1.15)	.053 (1.35)	.073 (1.85)	.089 (2.25)	.031 (0.80)	.039 (1.00)	.079 (2.00)	.091 (2.30)	.051 (1.30)	.051 (1.30)

CASE #	L	M	N	P	Q	R	S	T	WT. GRAM
CA1389	.026 (0.65)	-	.006 (0.15)	.012 (0.30)	.004 (0.09)	.007 (0.165)	.012 (0.31)	-	.010

Dimensions are in inches (mm). Tolerances: 2Pl. $\pm .01$; 3Pl. $\pm .005$

Notes:

- Case material: Plastic.
- Termination finish:
For RoHS Case Styles: Matte Tin plate.
- Primary dimensions are in millimeters.

Tape & Reel Packaging TR-F101

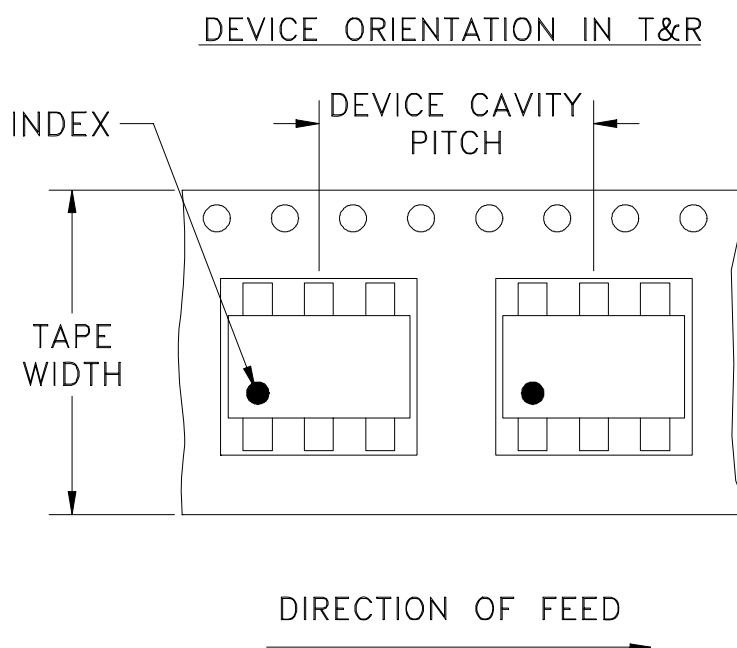

Tape Width, mm	Device Cavity Pitch, mm	Reel Size, inches	Devices per Reel	
8	4	7	Small quantity standards (see note)	20
				50
				100
				200
				500
				1000
		7	Standard	2000

Note: Please Consult individual model data sheet to determine device per reel availability.

Mini-Circuits carrier tape materials provide protection from ESD (Electro-Static Discharge) during handling and transportation. Tapes are static dissipative and comply with industry standards EIA-481/EIA-541.

Go to: www.minicircuits.com/pages/pdfs/tape.pdf



INTERNET <http://www.minicircuits.com>

P.O. Box 350166, Brooklyn, New York 11235-0003 (718) 934-4500 Fax (718) 332-4661

Distribution Centers NORTH AMERICA 800-654-7949 • 417-335-5935 • Fax 417-335-5945 • EUROPE 44-1252-832600 • Fax 44-1252-837010

Mini-Circuits ISO 9001 & ISO 14001 Certified

THIRD ANGLE PROJECTION

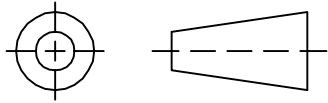

REVISIONS

REV	ECN No.	DESCRIPTION	DATE	DR	AUTH
OR	M124707	NEW RELEASE	10/08/09	MMG	DJ

SUGGESTED MOUNTING CONFIGURATION FOR CA1389 CASE STYLE, "06AM02" PIN CODE

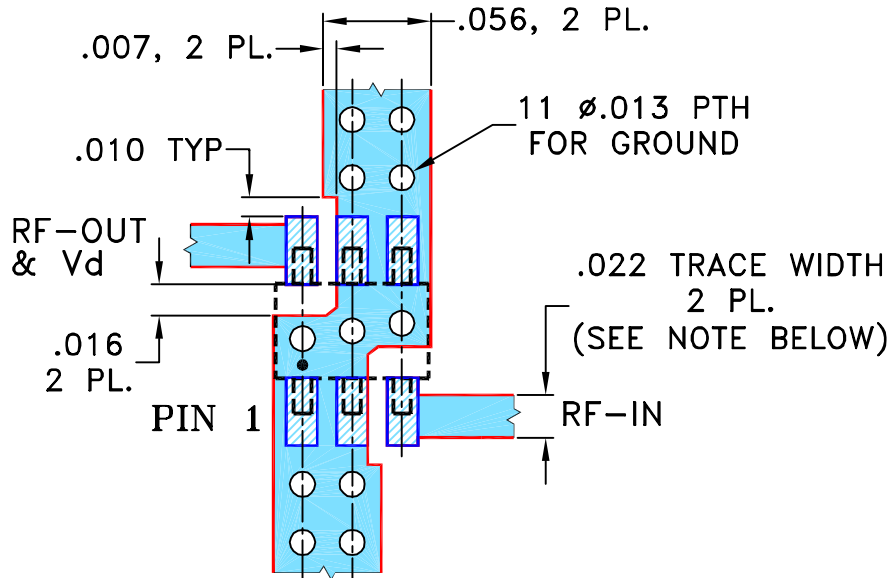

- NOTES: 1. TRACE WIDTH IS SHOWN FOR ROGERS RO4350B WITH DIELECTRIC THICKNESS .010" ± .001"; COPPER: 1/2 OZ. EACH SIDE. FOR OTHER MATERIALS TRACE WIDTH MAY NEED TO BE MODIFIED.
 2. BOTTOM SIDE OF THE PCB IS CONTINUOUS GROUND PLANE.



DENOTES PCB COPPER LAYOUT WITH SMOBC (SOLDER MASK OVER BARE COPPER)

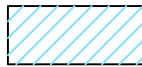

DENOTES COPPER LAND PATTERN FREE OF SOLDER MASK

UNLESS OTHERWISE SPECIFIED	INITIALS	DATE
DIMENSIONS ARE IN INCHES	DRAWN MMG	10/01/09
TOLERANCES ON:	CHECKED IL	10/07/09
2 PL DECIMALS ±	APPROVED DJ	10/08/09
3 PL DECIMALS ± .005		
ANGLES ±		
FRACTIONS ±		



Mini-Circuits®

13 Neptune Avenue
Brooklyn NY 11235

PL, 06AM02, CA1389, TB-539+

Mini-Circuits®
 THIS DOCUMENT AND ITS CONTENTS ARE THE PROPERTY OF MINI-CIRCUITS. EXCEPT FOR USE EXPRESSLY GRANTED, IN WRITING, TO ITS VENDORS, VENDEE AND THE UNITED STATES GOVERNMENT, MINI-CIRCUITS RESERVES ALL PROPRIETARY DESIGN, USE, MANUFACTURING AND REPRODUCTION RIGHTS THERETO. THESE CONTENTS SHALL NOT BE USED, DUPLICATED OR DISCLOSED TO ANY OUTSIDE PARTY, IN WHOLE OR IN PART, WITHOUT WRITTEN PERMISSION OF MINI-CIRCUITS.

SIZE	CODE IDENT	DRAWING NO:	REV:
A	15542	98-PL-316	OR
FILE:	98PL316	SCALE: 10:1	SHEET: 1 OF 1

Evaluation Board and Circuit

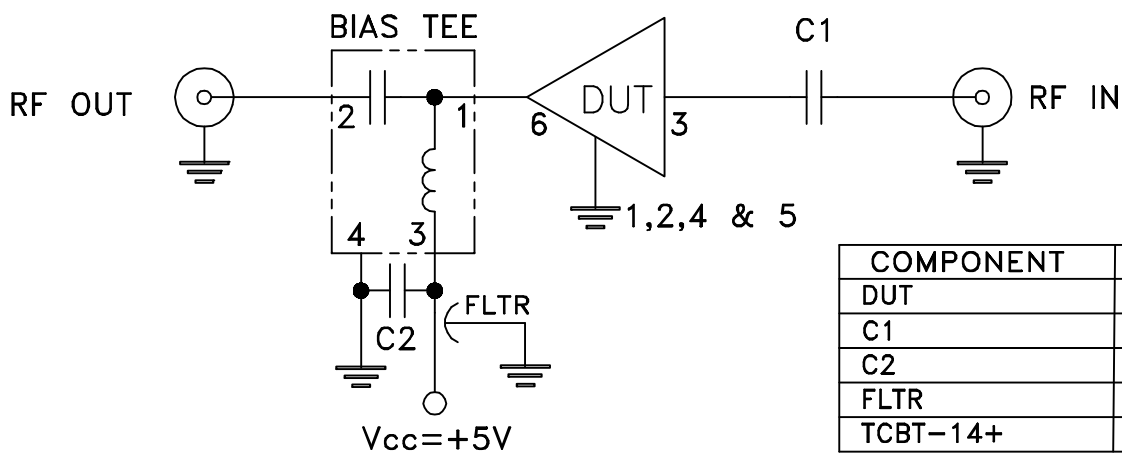
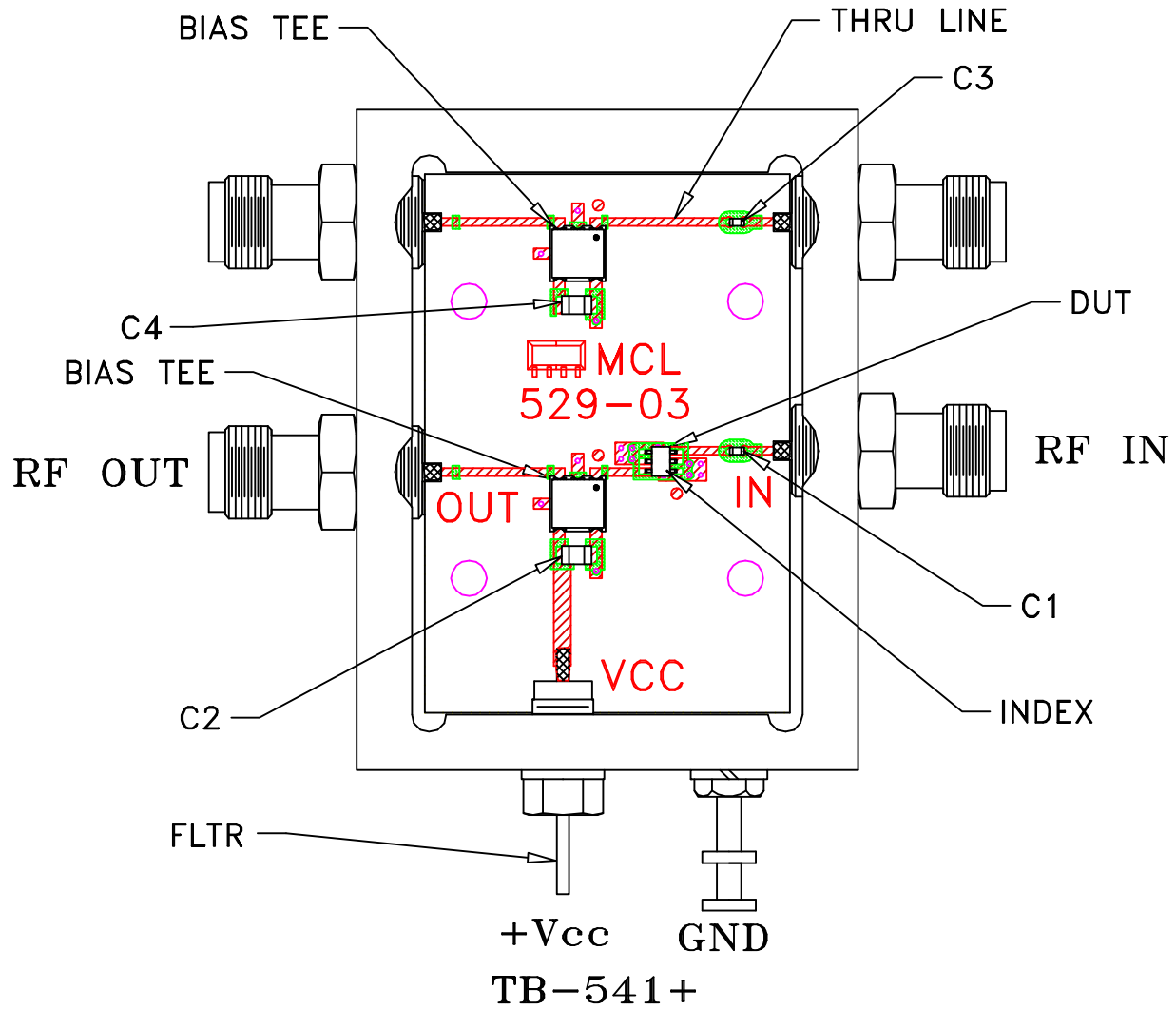

COMPONENT	VALUE
DUT	PSA-0012+
C1	1000 pF
C2	0.1 uF
FLTR	1500 pF
TCBT-14+	MCL BIAS-TEE

Schematic Diagram

Notes:

- 50 Ohm SMA Female connectors.
- PCB Material: R04350 or equivalent, Dielectric Constant=3.5, Thickness=.010 inch.

 **Mini-Circuits®**

All Mini-Circuits products are manufactured under exacting quality assurance and control standards, and are capable of meeting published specifications after being subjected to any or all of the following physical and environmental test.

Specification	Test/Inspection Condition	Reference/Spec
Operating Temperature	-45° to 85°C or -40° to 85°C Ambient Environment	Individual Model Data Sheet
Storage Temperature	-65° to 150° C Ambient Environment	Individual Model Data Sheet
Thermal Shock	-55° to 100°C, 100 cycles	MIL-STD-202, Method 107, Condition A-3, except +100°C
Mechanical Shock	1.5Kg, 0.5 ms, 5 shock pulses, Y1 direction only	MIL-STD-883, Method 2002, Condition B, except Y1 direction only
Vibration (Variable Frequency)	50g peak	MIL-STD-883, Method 2007, Condition B
Autoclave	15 psig, 100% RH, 121°C, 96 hours	JESD22-A102, Condition C
HAST	130°C, 85% RH, 96 hours	JESD22-A110
Solderability	10X Magnification	J-STD-002, Para 4.2.5, Test S, 95% Coverage
Solder Reflow Heat	Sn-Pb Eutetic Process: 240°C peak Pb-Free Process: 260°C peak	J-STD-020, Table 4-1, 4-2 and 5-2; Figure 5-1
Moisture Sensitivity: Level 1	Bake at 125°C for 24 hours Soak at 85°C/85% RH for 168 hours, Reflow 3 cycles at 260°C peak	J-STD-020
Marking Resistance to Solvents	Isopropyl alcohol + mineral spirits at 25°C; terpene defluxer at 25°C; distilled water + proylene glycol monomethyl ether +	MIL-STD-202, Method 215



All Mini-Circuits products are manufactured under exacting quality assurance and control standards, and are capable of meeting published specifications after being subjected to any or all of the following physical and environmental test.

Specification	Test/Inspection Condition	Reference/Spec
	monoethanolamine at 63°C to 70°C	